



भारत सरकार Government of India

विद्युत मंत्रालय Ministry of Power

उत्तर पूर्वी क्षेत्रीय विद्युत समिति

North Eastern Regional Power Committee

एन ई आर पी सी कॉम्प्लेक्स, डोंग पारमाओ, लापालाङ, शिल्लोंग-७९३००६, मेघालय

NERPC Complex, Dong Parmaw, Lapalang, Shillong - 793006, Meghalaya

SPEED POST/FAX

Ph : 0364-2534039

Fax: 0364-2534040

email: nerpc@ymail.com

website: www.nerpc.gov.in

No.: No. NERPC/NETeST/2024/546-585

May 28, 2024

To

As per list attached

Sub: Minutes of the 28th NETeST Coordination Committee Meeting

Sir/Madam,

Please find enclosed herewith the minutes of the 28th NETeST Meeting held on 14th May, 2024 at "NERPC Conference Hall, Shillong" for your kind information and necessary action. The minutes is also available on the website of NERPC: www.nerpc.gov.in.

Any comments/observations may kindly be communicated to NERPC Secretariat at the earliest.

Encl: As above

भवदीय / Yours faithfully,

(अनिल कवरानी/ Anil Kawrani)

निदेशक / Director

Distribution List:

1. Managing Director, AEGCL, Bijuli Bhawan, Guwahati – 781 001
2. Managing Director, APGCL, Bijuli Bhawan, Guwahati – 781 001
3. Managing Director, APDCL, Bijuli Bhawan, Guwahati – 781 001
4. Managing Director, MSPCL, Electricity Complex, Keishampat, Imphal – 795 001
5. Managing Director, MSPDCL, Secure Office Bldg. Complex, South Block, Imphal – 795 001
6. Director (Transmission), MePTCL, Lumjingshai, Short Round Road, Shillong – 793 001
7. Director (Generation), MePGCL, Lumjingshai, Short Round Road, Shillong – 793 001
8. Director (Distribution), MePDCL, Lumjingshai, Short Round Road, Shillong – 793 001
9. Director (Tech.), TSECL, Banamalipur, Agartala -799 001.
10. Director (Generation), TPGCL, Banamalipur, Agartala -799 001.
11. Chief Engineer (WE Zone), Department of Power, Govt. of Arunachal Pradesh, Itanagar- 791111
12. Chief Engineer (TP&MZ), Department of Power, Govt. of Arunachal Pradesh, Itanagar- 791111
13. Chief Engineer (Commercial) -cum- CEI, DoP, Govt. of Arunachal Pradesh, Itanagar- 791111
14. Engineer-in-Chief, P&E Department, Govt. of Mizoram, Aizawl – 796 001
15. Engineer-in-Chief, Department of Power, Govt. of Nagaland, Kohima – 797 001
16. ED (O&M), NEEPCO Ltd., Brookland Compound, Lower New Colony, Shillong-793003
17. ED (O&M), NHPC, NHPC Office Complex, Sector-33, Faridabad, Haryana-121003
18. Group GM, NTPC, Bongaigoan Thermal Power Project, P.O. Salakati, Kokrajhar- 783369
19. Vice President (Plant), OTPC, Badarghat Complex, Agartala, Tripura - 799014
20. ED, PGCIL/NERTS, Dongtiah-Lower Nongrah, Lapalang, Shillong -793 006
21. AGM (BD), NVVN, Core 5, 3rd floor, Scope Complex, 7 Institutional Area, Lodhi Rd., N. Delhi-3
22. Vice President, PTCIL, 2nd Floor, NBCC Tower, 15, Bhikaji Cama Place, New Delhi – 110066
23. Dy. COO, CTUIL, “Saudamini”, 1st Floor, Plot No. 2, Sector-29, Gurugram, Haryana – 122001
24. Chief Engineer, GM Division, Central Electricity Authority, New Delhi – 110066
25. Chief Engineer, NPC Division, Central Electricity Authority, New Delhi – 110066
26. Head & VP, (R&C), ENICL, IndiGrid, Windsor Building, Kalina, Santacruz (East), Mumbai- 98
27. ED, NERLDC, Dongtiah, Lower Nongrah, Lapalang, Shillong -793 006
28. CGM, AEGCL, Bijuli Bhawan, Guwahati – 781001
29. CGM, APGCL, Bijuli Bhawan, Guwahati – 781001
30. CGM, DISCOM, Bijuli Bhawan, Guwahati – 781001
31. Head of SLDC, Dept. of Power, Govt. of Arunachal Pradesh, Itanagar – 791111
32. CGM, (LDC), SLDC Complex, AEGCL, Kahilipara, Guwahati-781 019
33. Head of SLDC, MSPCL, Imphal – 795001
34. Head of SLDC, MePTCL, Lumjingshai, Short Round Road, Shillong – 793 001
35. Head of SLDC, P&E Deptt. Govt. of Mizoram, Aizawl – 796 001
36. Head of SLDC, Dept. of Power, Govt. of Nagaland, Dimapur – 797103
37. Head of SLDC, TSECL, Agartala – 799001
38. Chief Engineer (Elect), Loktak HEP, Vidyut Vihar, Kom Keirap, Manipur- 795124
39. DGM (O&M), OTPC, Badarghat Complex, Agartala, Tripura – 799014
40. Director, NETC, 2C, 3rdFloor, D21Corporate Park, DMRC Building Sector 21, Dwarka, Delhi-77.

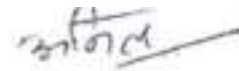

(अनिल कवरानी/ Anil Kawrani)

निदेशक / Director



सत्यमेव जयते

MINUTES
OF
28TH NETeST MEETING

Time of meeting : 11:30 Hrs.

Date of meeting : 14th May, 2024 (Tuesday)

Venue : NERPC Conference Hall, Shillong

Contents

1. PART-A: CONFIRMATION OF MINUTES	4
1.1. Confirmation of Minutes of 27 th Meeting of NETeST Sub-Committee of NERPC	4
2. PART-B: ITEMS FOR DISCUSSION	5
AGENDA FROM NERPC	5
2.1. Guidelines on availability of communication system	5
2.2. Periodic Auditing of Communication Systems	5
2.3. Procedure on Outage Planning for Communication System.....	6
AGENDA FROM POWERGRID	7
2.4. Issuance of Trial Operation Certificate for UNMS system.	7
AGENDA FROM CTU	8
2.5. Dual reporting of RTU, PMU, VOIP, AGC etc applications on dual channel to RLDC and Back up RLDC.....	8
2.6. Inputs from Grid-India/ STUs to finalize scope/BoQ for VOIP Hotline exchange	10
2.7. Requirement of Additional FOTE for redundancy at AGC locations in NER: Revised Scheme	15
2.8. Scheme for OPGW replacement work on 132kV NEHU-Khliehriat ckt-II line 18	
2.9. Scheme for OPGW replacement work on 132 kV Kahilipara – Umtru - Umiam Stg. III – Umiam Stg. I – NEHU link.....	22
AGENDA FROM AEGCL.....	25
2.10. Discussion on requirements of Protection signal status like LBB, Master Trip and over current etc. for the state.....	25
2.11. Utilization of UNMS for monitoring the communication node percentage availability and sharing the reports with STUs and SLDCs.	26
2.12. Planning for installation of RTUs/Redundant Gateways in substation of states where ISTS lines are present.....	27
2.13. FOTE and DTPC integration and commissioning under NERPSIP	27
AGENDA FROM NERLDC.....	28
2.14. Connectivity of NERLDC Guwahati with Sarusajai and Umiam bypassing Kahilipara for its redundancy.....	28
2.15. Unauthorised usage of four (04) number of fibers in Panyor – Pare link.	29
2.16. Fiber requirement between Doyang and Sanis for Differential Protection...	30
AGENDA FROM PwC	30
2.17. SAMAST project related agenda	30
AGENDA FROM MEGHALAYA.....	33
2.18. Annual Maintenance Contract (AMC) of SAMAST project	33

3. PART-C: ITEMS FOR UPDATE/FOLLOW-UP	35
3.1. Project status of NERPSIP and Arunachal Pradesh Comprehensive Scheme 35	
3.2. Issues related to Maintenance activities of SCADA/EMS system of SLDCs (Agenda A.4 as per MoM of 27th NETeST Meeting)	35
3.3. Upgradation Activities of SCADA-EMS systems at Regional/State level in North-Eastern Region (Agenda A.2 as per MoM of 27th NETeST Meeting).....	36
3.4. Status of State reliable communication scheme (Agenda A.5 as per MoM of 27th NETeST Meeting).....	38
3.5. Implementation of Guwahati Islanding Scheme (Agenda A.8 as per MoM of 27th NETeST Meeting).....	40
3.6. Non-availability of real-time data pertaining to POWERGRID-owned bays installed at AEGCL-owned stations (Agenda A.11 as per MoM of 27th NETeST Meeting).....	41
3.7. Connectivity of 132 kV Khupi S/s with ULDC network (As per MoM Point A.12 of 27th NETeST Meeting).....	44
3.8. Cyber Security aspects in SCADA/IT systems at Load Despatch Centres in North Eastern Region (Agenda A.13 as per MoM of 27th NETeST Meeting).....	45
3.9. Concerned regarding shifting of SLDC Arunachal Pradesh from old building to new building (Agenda A.14 as per MoM of 27th NETeST Meeting).....	46
3.10. Restoration of OPGW owned by Manipur (Agenda A.15 as per MoM of 27th NETeST Meeting)	47
3.11. Establishment of redundant fibre path between NERLDC and NEHU for reliability of power system communication link till RLDC. (As per MoM Point A.17 of 27th NETeST Meeting and as per MoM of Special Meeting held on 7th Mar 2024) 48	
3.12. Replacement of FO link for “NERLDC Shillong – NEHU”, “132 kV Kahilipara- Sarusajai” and “132 kV Kahilipara – Umiam Stg. III – Umiam Stg. I – NEHU”. (As per MoM Point A.18 of 27th NETeST Meeting and as per MoM of Special Meeting held on 7th Mar 2024).....	51
3.13. Status of Fiber-Optic works under different projects (As per MoM Point B.2 of 27th NETeST).....	52
3.14. Status and details of Fiber-Optic projects approved in 17th TCC/RPC meeting (As per MoM point B.3 of 27th NETeST)	54
3.15. Integration of Dikshi HEP real time data and pending Voice communication (Agenda B.4 as per MoM of 27th NETeST).....	55
3.16. Automatic Generation Control (AGC) in Indian Grid (Agenda B.5 as per MoM of 27th NETeST).....	55
3.17. Pending issues of State Utilities of NER (Agenda B.6 as per MoM of 27th NETeST).....	61
3.18. Feasibility to connect Lekhi Substation over Fiber-Optic Network (Agenda B.7 as per MoM of 27th NETeST Meeting)	62

NORTH EASTERN REGIONAL POWER COMMITTEE

MINUTES OF 28TH NETeST MEETING HELD ON 14.05.2024 (TUESDAY) AT 11:30 HRS

Venue : NERPC Conference Hall, Shillong.

The List of Participants is attached at **Annexure – I**.

Shri K. B. Jagtap, Member Secretary, NERPC welcomed all the participants. He briefed participants about the importance of OCC, PCC and NETeST meeting. He stated that operation, protection and communication are equally important for smooth, safe and reliable operation of Grid. He also stressed on the availability of communication channel for SCADA, SEM and protection to ensure for smooth operation and reliable power supply. He mentioned about the importance of carrying out periodic audit of communication system as per CERC Communication Regulations-2017 which will be useful to remove any shortcomings. He further stressed on outage planning procedure for communication system of NER grid. Thereafter, the agenda items were taken up for discussion.

1. PART-A: CONFIRMATION OF MINUTES

1.1. Confirmation of Minutes of 27th Meeting of NETeST Sub-Committee of NERPC

The minutes of 27th meeting of NETeST Sub-committee held on 21st February, 2024 (Wednesday) at “Hotel Royale de’ Casa, Guwahati” were circulated vide letter No. No. NERPC/SE (O)/NETeST/2023/3413-3452 dated 6th March, 2024.

No comments have been received from the constituents.

The Sub-committee confirmed the minutes of 27th NETeST meeting of NERPC.

2. PART-B: ITEMS FOR DISCUSSION

AGENDA FROM NERPC

2.1. Guidelines on availability of communication system

CERC vide order dated 19.01.2024 had approved the “Guidelines on Availability of Communication System” (**Annexure-B.2.1**) under the Central Electricity Regulatory Commission (Communication System for inter-State transmission of electricity) Regulations, 2017.

Deliberation of the sub-committee:

NERPC delivered a brief presentation highlighting the NPC guidelines in compliance with CERC (Communication System for Inter-State Transmission of Electricity Regulations, 2017). These guidelines shall be applicable to CTU as well as to STUs until separate guidelines are issued for STUs by respective SERCs. As per the guidelines, CTU shall provide the list of channels for which the availability is to be calculated in consultation with NERPC and NERLDC (Grid-India). Further, CTU has to provide the outage details of communication channels to NERLDC for verification and NERLDC shall forward verified information to NERPC for computation of availability of the communication systems. CTU agreed to provide the list of channels as per guidelines. CTU agreed to provide the information within 2 weeks to NERPC/NERLDC.

The sub-committee noted as above.

Action: CTU, NERLDC

2.2. Periodic Auditing of Communication Systems

Regulation 10 of Communication System for inter-state transmission of electricity Regulation, 2017 states “The RPC Secretariat shall conduct performance audit of communication system annually as per the procedure finalized in the forum of the concerned RPC. Based on the audit report, RPC Secretariat shall issue necessary instructions to all stakeholders to comply with the audit requirements within the time stipulated by the RPC Secretariat. An Annual Report on the audit carried out by respective RPCs shall be

submitted to the Commission within one month of closing of the financial year”.

Final Standard Operating procedure (SOP) for Communication audit of Substations has been prepared in compliance to Central Electricity Regulatory Commission (Communication System for inter-State transmission of electricity) Regulations, 2017. This SOP for communication audit of substations is finalized to maintain uniformity at the national level (**Annexure B2.2**)

Deliberation of the sub-committee:

It was deliberated that to carry out the Communication Audit, a communication audit sub-group comprising of members from NERPC, NERLDC, SLDCs and Powergrid has to be formed in line with the SOP. In this regard nominations were sought from all SLDCs, NERLDC and Powergrid. Assam nominated Sh. Poonam Biswakarma, AGM and Sh. Rupjyoti Das, DM. NERLDC nominated Sh. Gaurav Bhattacharjee, AM and Sh. Subal Das, Engineer. NERPC nominated Sh. Alikpanth De, DD and Sh. Ashim Kumar Goswami, AD-II. Tripura nominated Smt. Shampa Sen, SM SLDC, TPTL and Sh. Partha Pratim. All other States and Powergrid confirmed to provide the nominations within 10 days via mail to NERPC. After receipt of all the nominations, a consolidated list of the group of members for communication audit shall be published by NERPC after due approval of Member Secretary, NERPC.

The sub-committee noted as above.

Action: Arunachal Pradesh, Meghalaya, Manipur, Mizoram, Nagaland and POWERGRID.

2.3. Procedure on Outage Planning for Communication System

As per Regulation 7.3 of Central Electricity Regulatory Commission (Communication System for inter-State transmission of electricity) Regulations, 2017:

Quote:

The RPC Secretariat shall be responsible for outage planning for communication system in its region. RPC Secretariat shall process outage planning such that uninterrupted communication system is ensured.

Unquote.

The SOP on “Procedure on Outage Planning for Communication System” was approved in the 14th NPC meeting held on 03.02.2024 at Bengaluru.

Detailed SOP of Communication System Outage Planning attached at **Annexure-B.2.3**

Deliberation of the sub-committee:

The sub-committee agreed that all the constituents shall submit the proposed outage list in the prescribed format for the next month to NERPC by 7th of every month. NERPC secretariat shall consolidate the list of outage proposals of communication links and equipment and circulate the same among all the respective regional entities by 15th of every month. The meeting for communication outage shall be taken up in the 3rd week of the month tentatively (preferably through VC). All the States were asked to provide the outage list of communication elements which are incidental to ISTS. Member Secretary, NERPC advised the forum to continue the practice from June-2024 onwards. All constituents agreed for the same.

The sub-committee noted as above.

AGENDA FROM POWERGRID

2.4. Issuance of Trial Operation Certificate for UNMS system.

The request for issuance of Trial Operation Certificate has already been forwarded by POWERGRID to Grid-India on 29.02.2024, however, the trial operation certificate has not been received yet.

Deliberation of the sub-committee:

NERLDC highlighted that as per clause 27d of IEGC-23, UNMS seems not to be covered under the ambit of NERLDC. Operationalization of UNMS is the

responsibility of CTU, as CTU is the nodal agency for planning and monitoring communication system for ISTS elements. Member Secretary, NERPC advised POWERGRID and CTU to address the issue bilaterally.

Regarding the pending integration of UNMS, NERLDC informed that integration of FOTE of various TSPs such as Sterlite, KMTL and Indigrd is pending. NERLDC informed that integration of NMS of NERPSIP and Comprehensive T&D-Arunachal Pradesh are pending.

States were requested to give a list to POWERGRID where UNMS installation is still pending. POWERGRID assured to address the issue.

Tripura also informed that SDH panels were malfunctioning, to which NERPSIP responded by assuring that integration agency will visit in 2 weeks' time to resolve the integration issues.

The sub-committee noted as above.

AGENDA FROM CTU

2.5. Dual reporting of RTU, PMU, VOIP, AGC etc applications on dual channel to RLDC and Back up RLDC.

Presently, all the data channels and voice channels are reporting in main and backup mode with a main channel to RLDC and protection channel to Backup RLDC. It is suggested by ERLDC & WRLDC that for increase of redundancy in the system both main and protection channels should report to RLDCs as well as back up to RLDCs in dual mode considering the criticality of real grid operations by the ERLDC.

For discussing the same meetings were held among POWERGRID, Grid-India, CTU and CEA on dated 09/05/23 and 27/06/23. As per discussion in meeting, POWERGRID had to provide the region wise data of additional requirement for equipment/card/port etc in respective FOTE/Gateway/RTU for the implementation of dual redundancy within 21 days.

A virtual meeting with POWERGRID GA &C was held on 02.11.2023(MoM attached as **Annexure Ia**) for Dual reporting of RTU, PMU, VOIP, AGC etc. applications on 2+2 channel to main RLDC and Backup RLDC for North Eastern Region where in the requirement of one no. of SDH with minimum 8 no. of ethernet ports was agreed in the meeting for Ziro S/s.

POWERGRID CC AM dept. has provided the required data pertaining to SAS/RTU as per attached **Annexure Ib**.

Deliberations in 5th CPM:

POWERGRID confirmed that requirement given for SAS and RTU based substation is for new SAS and RTU respectively and the cost provided is for each new SAS/new RTU per station.

CEA informed that they will go through this agenda and provide their views. CEA vide email dtd.28.02.2024 has informed that they are agreed with the agenda.

The scheme shall be put up for RPC review accordingly.

Deliberation in 27th NETeST meeting:

SLDC, Assam requested the forum to consider implementing regulatory bounded redundancy projects via PSDF funding as the financial health of NER states are poor. The forum noted the submission of SLDC, Assam and advised CTUIL to share the network architecture of the scheme/agenda with SLDC, Assam.

Based on the data provided by POWERGRID AM and GA & C, requirement in NER is as follows:

No. of minimum 8 ethernet port STM 16 FOTE at Ziro S/s:01 No.

No. of new SAS required as per **Annexure Ib** :14 Nos.

No. of new RTU required as per **Annexure Ib**: 06 Nos.

Estimated cost for one no. STM 16 FOTE: Rs 30 Lacs

Estimated cost for SAS and RTU as per **Annexure Ib**:(1.5x 14) + (0.3x 06) =
Rs 22.8 Crores

Total estimated cost for NER region: Rs 23.1 Crs

Regarding PSDF funding, POWERGRID shall prepare a DPR for this project and submit for PSDF funding. Based on the comments of PSDF forum, scheme shall be taken up accordingly.

Deliberation of the sub-committee:

CTU representative briefed the agenda item. Assam and Tripura responded that the cost implication is very high for the States. Keeping in mind, the financial constraints of the NER States, all the States requested CTU to apply for PSDF funding.

NERPC advised CTU to explore the possibility of using spare STM 16 FOTE instead of procuring new STM 16 FOTE to reduce the cost implications. Member Secretary, NERPC opined that CTU can plan for redundancy including all ISTS, ISGS and TPS keeping in mind the cost-benefit analysis.

The sub-committee noted as above.

2.6. Inputs from Grid-India/ STUs to finalize scope/BoQ for VOIP Hotline exchange

1. Hot Line Speech Communication System (VOIP based PABX system) was implemented in 2016 by POWERGRID in all five regions after grid disturbance in 2012 where grid operators faced problem of fast communication due to unavailability of dedicated speech communication PAN India between NLDC, RLDCs, SLDCs, important state and ISTS substations and generators. The said PABX was implemented by M/s Orange through Alcatel Lucent as OEM.
2. In the 67th NRPC meeting, POWERGRID representative stated that the scheme executed by M/s ORANGE was with a provision of AMC of 7 years as part of the contract and the same is expiring in July' 2023 for most of the sites.
3. AMC of the same was extended and approved in the 67th NRPC for further 2 years upto July'25 with financial implication and shall be

booked in ULDC O&M charges as per the CERC norms. After July'25 no support shall be extended by Alcatel (OEM).

4. In 67th NRPC Meeting, MS, NRPC advised CTU to plan upgradation/ new system and implementation of existing Hot line speech communication or new EPABX system timely in view of expiration of AMC in July'25.
5. It is understood that during the execution of the said project, RPCs approval was sought in all regions and cost of the project was booked in the ongoing Communication System packages of the respective regions. So, it is understood that useful life of hotline speech communication is 15 years per CERC tariff regulation.
6. In the 23rd TeST meeting NRPC advised CTU to take up the planning and approval process parallelly as POWERGRID shall file petition to CERC in 2024 for revised depreciation. It was deliberated that as the AMC extension has been approved by POWERGRID for 2 years, meanwhile CERC order will be pursued during this time. CTU also requested that POWERGRID shall provide a copy of petition for which POWERGRID agreed.
7. In view of above CTU is planning a new EPABX system which shall replace the existing system within 2 years.
8. CTU has discussed the requirement with various VOIP Exchange suppliers and proposed VOIP System Architecture is attached at Appendix-I. Salient features of proposed VOIP system are given below:
 - Server based architecture
 - Multiple level of redundancy in compared to present system e.g. If RLDC exchange failed complete load shall be transferred to backup RLDC. If both Main & Backup RLDC failed NLDC server can take complete load. At state level Main & Backup Server are proposed for main and backup SLDC. If main SLDC server failed, backup will take entire load if both main & backup SLDC failed complete load shifted to RLDC servers.
 - For cost optimization main and backup servers works in dual mode as main as well as backup of backup RLDC servers vice-versa
 - NMS for adding/ deleting users shall be provided at RLDC/ SLDC levels

- Operator console shall be provided to manage calls at RLDC/SLDC
- Call recording features shall be provided at RLDC & SLDC level
- VOIP, Digital, Analog, Four Wire E&M (at PLCC) locations are considered
- Video Phones at RLDC/ SLDC for Senior officials
- Trunk lines for outside calling, recurring tariff of trunk lines to be borne by respective utilities
- Sufficient numbers of licenses to cater future RE/ ISTS/ ISGS/ IPP locations and STU substations' locations.

9. A presentation is also arranged by prospective OEM of VOIP M/s Coral in the meeting.

10. To finalize the BoQ & Scope following inputs are required from RLDC/ Grid-India and STUs no. of subscribers/locations: format

Exchange	No of phones (VOIP)-BASIC		No of phones (VOIP)-ADVACNE VIDEO		SIP TRUNK (BSNL/ JIO ETC)	PRI Line (BSNL/A irtel etc.)	CO/Trunk Line (BSNL/A irtel etc.)	Radio Interface Port	Digit al phones with one touch dial	Analog Phones		Voice Recorder (for 6 months storage)
	Local	Remote	Local	Remote					2 W	4W E& M (PLC C)		
NLDC												
RLDC												
SLDC												
Frequency of voice recording backup												Daily/ Weekly/Monthly

Note: For the existing VOIP exchange data is enclosed as **Annexure II**

11. Location for NERLDC, Backup NERLDC, SLDC, backup SLDCs as mentioned below are to be confirmed:

Sr No.	Main CC Location	Backup CC location
1	Backup NERLDC	
2	SLDC, A.P	
3	SLDC,Meghalaya	
4	SLDC,Mizoram	
5	SLDC,Manipur	
6	SLDC,Nagaland	
7	SLDC,Assam	

12. Location of Remote locations

13. Proposal to be discussed in the all 5 regions and combined proposals may be prepared after taking inputs from all regions and cost estimates.

An online meeting on this agenda was held on 02.05.2024 wherein one of the prospective bidder made the presentation on the same and various queries of state constituents/RPC/RLDC were addressed. Broadly, it was agreed to provide the data by STUs as per format circulated earlier during the TeST meeting to design the VoIP scheme.

Appendix-I

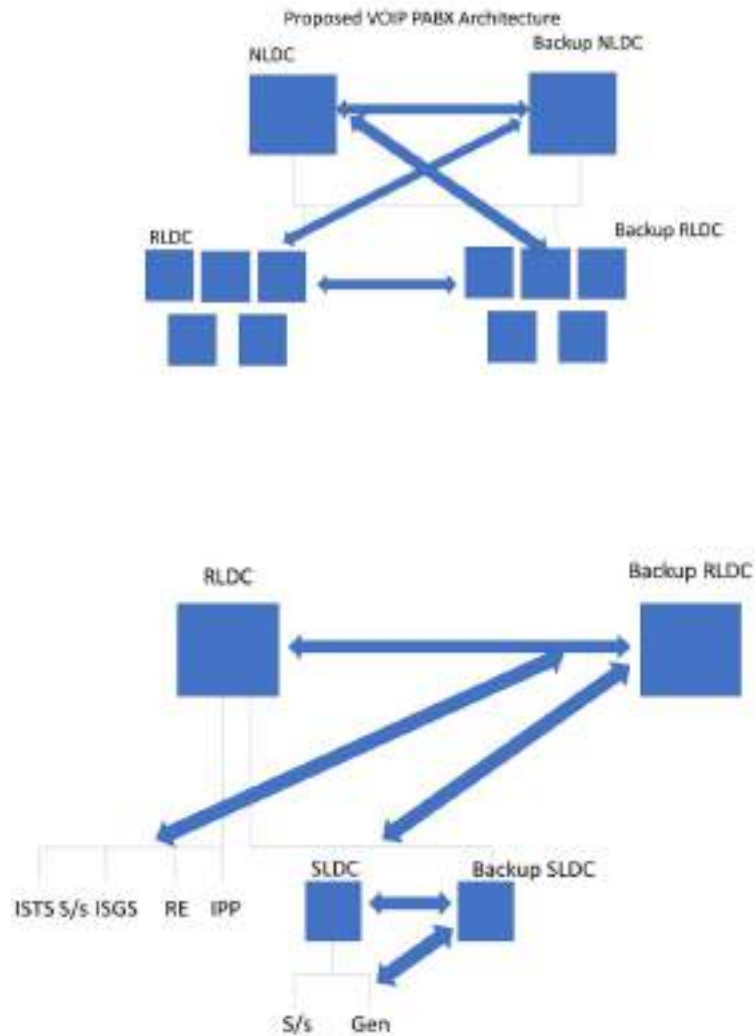

Deliberation of the sub-committee:

CTU informed that data has been received from Arunachal Pradesh only. Assam and Tripura submitted that communication system architecture, as proposed in Appendix-I, is not clear. The forum requested CTU to conduct a separate meeting with the NER States to clarify their doubts regarding the proposal. CTU assured that an online meeting would be convened within a week for addressing the requirements of all the states.

The sub-committee noted as above.

2.7. Requirement of Additional FOTE for redundancy at AGC locations in NER: Revised Scheme

The scheme for requirement of Additional FOTE for redundancy at AGC locations in NER has been sent for review to NERPC vide email dated 02.01.2024. In the said scheme requirement of FOTE at Kameng Plant was not incorporated due to non receipt of input from POWERGRID. As per inputs of POWERGRID regarding Kameng Plant in the 5th CPM of CTU, the scheme has been revised which is as follows:

S. No.	Items	Details
1.	Scope of the scheme	Requirement of 3 nos. of STM-16 FOTE at AGC locations of North Eastern Region for redundancy.
2.	Depiction of the scheme on FO Map	NA
3.	Objective / Justification	<p>Additional FOTE at all AGC operated generating stations in North Eastern region is required in view of resource disjoint and criticality of AGC operation for grid operation purpose as failure of single equipment may lead to disruption in AGC operation. Further, at many locations redundant ethernet port are not available as per NLDC requirement. The NLDC requirement is as follows:</p> <ul style="list-style-type: none"> ➤ 1+1 Ethernet port for main NLDC ➤ 1+1 Ethernet ports are for backup NLDC <p>The list of AGC locations and equipment requirement is enclosed as Appendix-II.</p> <p>The total three nos. of FOTE STM16 equipments are required for redundancy as per enclosed list.</p>

4.	Estimated Cost	Rs. 90 lacs (approx.) (Ninety lacs only)
5.	Implementation time frame	06 months from date of allocation.
6.	Implementation mode	To be implemented by POWERGRID in RTM mode.
7.	Deliberations	<p>The AGC scheme for Loktak and Bongaigaon locations was deliberated in 25th NETeST meeting held on 25.05.2023 wherein the members agreed for the same. This scheme was thereafter discussed and reviewed in 24th TCC & NERPC meeting and approved in 16th NCT meeting for two no. of AGC locations i.e. Loktak and Bongaigaon.</p> <p>In the 4th Communication Planning meeting (CPM) (MoM attached as Annexure A) of CTUIL held on 28.07.2023, NERLDC suggested five no. of additional locations for AGC as per enclosed Appendix-II. The agenda for this scheme was then deliberated in 26th NETeST meeting held on 10.10.2023 (MoM attached as Annexure B) wherein NERLDC suggested for adding three no. of additional AGC locations i.e. Kameng, Pallatana, Lower Subansari for redundancy planning. Accordingly, the AGC redundancy scheme was prepared including these locations and resulted into requirement of three additional FOTE at Doyang, Pallatana, Lower Subansiri as given in Appendix-II based on inputs provided by POWERGRID/ISGS. This revised scheme is put up for NERPC review. Post NERPC review, scheme shall be put up to NCT for approval.</p>

Appendix II

List for Requirement of Additional FOTE in NER at AGC locations

Sr No.	Name	Required FOTE as per input provided by POWERGRID/ISGS (Qty in No.)	Remark
1	Loktak	0	Additional FOTE already approved in 16th NCT and awarded
2	Bongaigaon	0	Additional FOTE already approved in 16th NCT and awarded
3	Kopili	0	NERLDC suggested additional stations for AGC in 4th CPM
4	Khandong	0	NERLDC suggested additional stations for AGC in 4th CPM
5	Kathalguri	0	NERLDC suggested additional stations for AGC in 4th CPM
6	Kopili Stage-2	0	NERLDC suggested additional stations for AGC in 4th CPM
7	Doyang HEP (NTPC+NEEPCO)	1	NERLDC suggested additional stations for AGC in 4th CPM
8	Kameng (NEEPCO)	0	NERLDC suggested additional stations for AGC in 26th NE TeST
9	Pallatana (OTPC)	1	NERLDC suggested additional stations for AGC in 26th NE TeST
10	Lower Subansiri (NHPC)	1	NERLDC suggested additional stations for

		AGC in 26th NE TeST, Upcoming Plant
Total FOTE quantity required in this scheme	03	

Deliberation of the sub-committee:

CTU and NERLDC informed the forum that initially status of Kameng was not available. However, after the status of Kameng was made available, it was confirmed that AGC was not required for Kameng. Hence, the revised scheme is put up for information of the forum only where AGC is proposed for Doyang, Palatana, Lower Subansiri i.e. 3 nos only.

NERPC opined that CTU may explore the possibility of using spare STM 16 FOTEs, if available, instead of procuring new STM 16 FOTEs to reduce the cost burden on the NER states and in case non availability of spare, AGC can be implemented at Doyang, Palatana, Lower Subansiri as per regulation.

The sub-committee noted as above.

2.8. Scheme for OPGW replacement work on 132kV NEHU-Khliehriat ckt-II line

S. No.	Items	Details
1.	Scope of the scheme	Replacement of 12F existing OPGW by 48F OPGW on 132kV NEHU-Khliehriat ckt-2
2.	Depiction in diagram	Connectivity of NERLDC is as shown in Appendix-III
3.	Objective / Justification	Present Connectivity to NERLDC, Shillong is as follows: 12F OPGW on 132kV NEHU-Khliehriat ckt-2 line is extended from tower T23 of this line, through 12F underground FO cable laid upto NERLDC, Shillong.

		<p>Thus,12F OPGW on 132kV NEHU-Khliehriat ckt-II line contains critical ISTS data and at present this is the only path for NERLDC connectivity. 12F OPGW between NEHU to Khliehriat was laid in ULDC phase-I by POWERGRID however, line ownership belongs to Meghalaya. This line has completed its useful life of 15 years and has deteriorated in its performance as informed by NERLDC. As such replacement of the same has become essential.</p> <p>The redundant path of NERLDC Shillong is planned as follows:</p> <p>24F OPGW is existing between 132 kV NEHU S/s and Tower 25 of 132 kV NEHU-Kheliriat line I. From Tower 25 to NERLDC,Shillong ,POWERGRID to lay and maintain the underground 48F cable under the ongoing reliable communication scheme.</p> <p>The instant scheme may be implemented after the redundant path for NERLDC,Shillong is established so that the data traffic to NERLDC,Shillong remains unaffected.</p>
4.	Estimated Cost	Rs. 4/- crores(approx.) excluding taxes
5.	Implementation time frame	18 months from date of allocation.
6.	Implementation agency	To be implemented by POWERGRID in RTM mode

7.	Deliberations	<p>The agenda for replacement of OPGW on NEHU-NERLDC, Shillong was deliberated in 23rd TCC and NERPC meeting (MoM attached as Annexure C) held on 18.11.2022 and 19.11.2022 respectively wherein the forum recommended for replacement of OPGW with 24 Fiber and referred the same to NCT (substantiated with test report). The same agenda was deliberated in 5th CPM for NER region of CTU held on 14.02.2024(MoM attached as Annexure D), wherein it was proposed that POWERGRID shall lay and maintain 48F OPGW on NEHU-NERLDC, Shillong. Out of 48 fibers, 24 fibers will be for ISTS use and rest 24 fibers for state purpose.</p> <p>In the special review meeting of NERPC held on 07.03.2024 (MoM attached as Annexure E), the forum suggested to upgrade the OPGW on 132kV NEHU-Khliehriat ckt-II line to 48F by POWERGRID in consultation with CTU.</p> <p>Accordingly, this scheme for laying of 48F on 132kV NEHU-Khliehriat ckt-II line has been prepared and is put up to NERPC for review. Post NERPC review scheme shall be put up to NCT for approval.</p>
----	---------------	---

Appendix-III

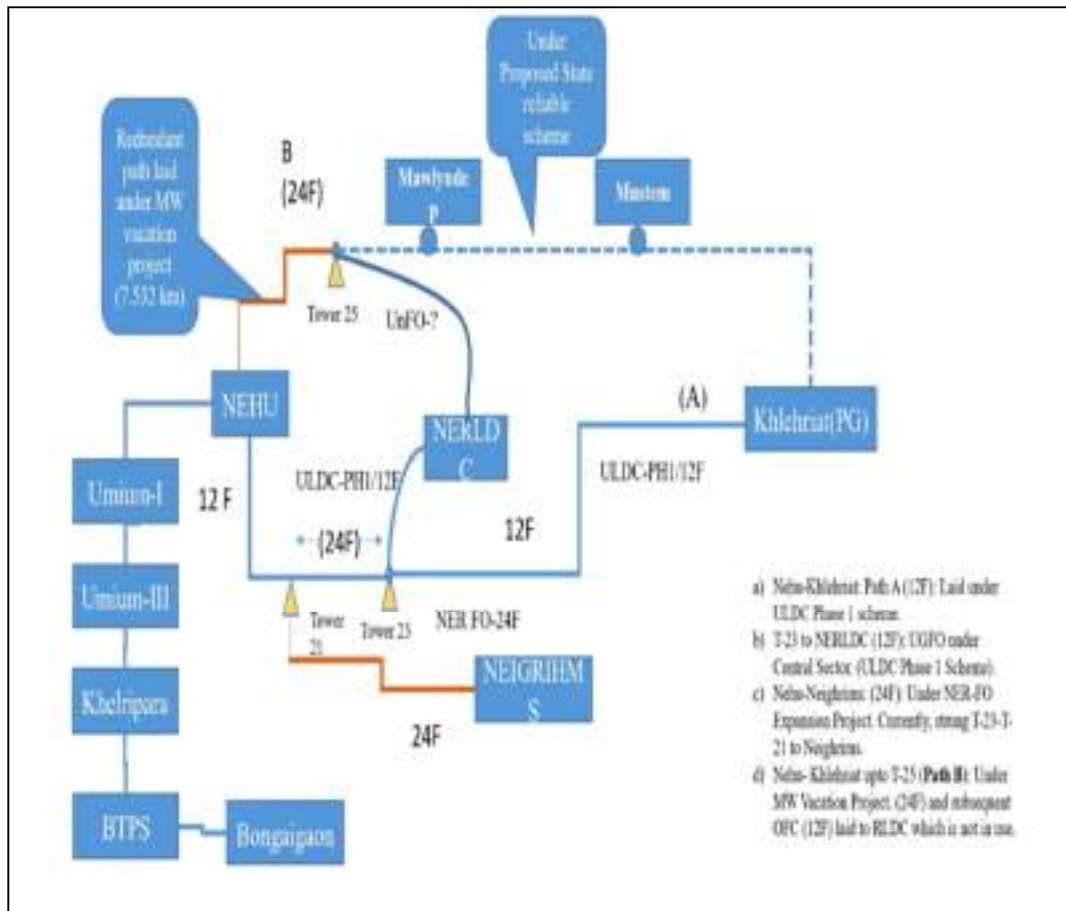

Deliberation of the sub-committee:

NERLDC mentioned that 132 kV NEHU -Khlehriat(PG) link (bold line in diagram) is designated as circuit 1 and 132 kV NEHU-Khlehriat(PG) link (dotted line in diagram) is circuit 2. The forum decided to rename 132 kV NEHU – Khlehriat ckt 1 to 132 kV NEHU – NEIGRIHMS – Khlehriat line.

CTU will take NCT approval of 48F OPGW of 132 kV NEHU – NEIGRIHMS – Khlehriat line and of 48F UG from Tower 25 of 132 kV NEHU – Mawlyndep line to NERLDC.

Communication link from Tower-23 to NERLDC is already part of the Reliable communication Scheme and is already approved. ULDC – POWERGRID

informed that PwD Meghalaya’s clearance has been obtained for laying 24F UG Cable from Tower 23 of 132 kV NEHU – NEIGRIHMS line to NERLDC.

132 kV NEHU-Mawlyndep-Mustem-Khliehriat line (132 kV NEHU – Khliehriat CKT-II) is under the State reliable communication Scheme of Meghalaya.

The sub-committee noted as above.

2.9. Scheme for OPGW replacement work on 132 kV Kahilipara – Umtru - Umiam Stg. III – Umiam Stg. I – NEHU link

S. No.	Items	Details
1.	Scope of the scheme	Establishment of 48F fiber link on 132 kV Kahilipara – Umtru - Umiam Stg. III –Umiam Stg. I –NEHU(approx. 59.3 kms) by replacing the 12F fiber in 132 kV Kahilipara – Umiam Stg. III – Umiam Stg. I – NEHU link.
2.	Depiction of the scheme	As shown in diagram at Appendix-IV
3.	Objective / Justification	Backup NERLDC at Kahilipara, Guwahati is connected through 12F fiber link of 132kV Kahilipara – Umiam Stg. III – Umiam Stg. I –NEHU which was installed under ULDC Phase-1 scheme by POWERGRID. This Meghalaya owned link has exceeded its life-span of 15 years and has deteriorated in its performance as informed by NERLDC. In order to maintain reliability of communication system at mission-critical establishment of NERLDC as well as regional communication backbone network, it is essential to replace the

		<p>12F link on 132kV Kahilipara – Umiam Stg. III – Umiam Stg. I –NEHU with 48F fiber link.</p> <p>In the special review meeting of NERPC held on 07.03.2024, MePTCL made a request to connect the 132 kV Kahilipara –Umiam Stage III line at 132 kV Umtru also for improved connectivity. The forum agreed to the same and endorsed the establishment of the link as 132 kV Kahilipara – Umtru - Umiam Stg. III – Umiam Stg. I – NEHU.</p>
4.	Estimated Cost	Rs. 5/- crores (approx.) excluding taxes
5.	Implementation time frame	18 months from date of allocation.
6.	Implementation agency	To be implemented by POWERGRID in RTM mode
7.	Deliberations	<p>The agenda for replacement of 12F fiber on 132kV Kahilipara – Umiam Stg. III – Umiam Stg. I –NEHU link was deliberated in 23rd TCC and NERPC meeting (MoM attached as Annexure F) held on 18.11.2022 and 19.11.2022 respectively wherein the forum recommended for replacement of existing fiber with 24 Fiber and referred the same to NCT (substantiated with Fiber healthiness test report).</p> <p>The same agenda was deliberated in 5th CPM for NER region of CTU held on 14.02.2024(MoM attached as Annexure G),wherein it was proposed that POWERGRID shall lay and maintain 48F fiber on 132kV Kahilipara – Umiam Stg. III – Umiam Stg. I –NEHU link by replacing the existing 12F</p>

	<p>fiber. Out of 48 fibers, 24 fibers will be for ISTS use and rest 24 fibers for state purpose.</p> <p>Further,the agenda was deliberated in the special review meeting of NERPC held on 07.03.2024(MoM attached as Annexure H) wherein MePTCL made a request to connect the 132 kV Kahilipara – Umiam Stage III line at 132 kV Umtru for improved connectivity. The forum agreed to the same and endorsed the establishment of the 48F fiber link on 132 kV Kahilipara – Umtru - Umiam Stg. III – Umiam Stg. I – NEHU by replacing the existing 12F fiber link of 132kV Kahilipara – Umiam Stg. III – Umiam Stg. I –NEHU. Further, discussions regarding the distribution of OPGW between ULDC-POWERGRID and MePTCL to take place in subsequent meetings.</p> <p>Accordingly, this scheme for laying of 48F fiber on 132 kV Kahilipara – Umtru - Umiam Stg. III – Umiam Stg. I – NEHU link has been prepared and is put up to NERPC for review. Post NERPC review scheme shall be put up to NCT for approval.</p>
--	--

Appendix-IV

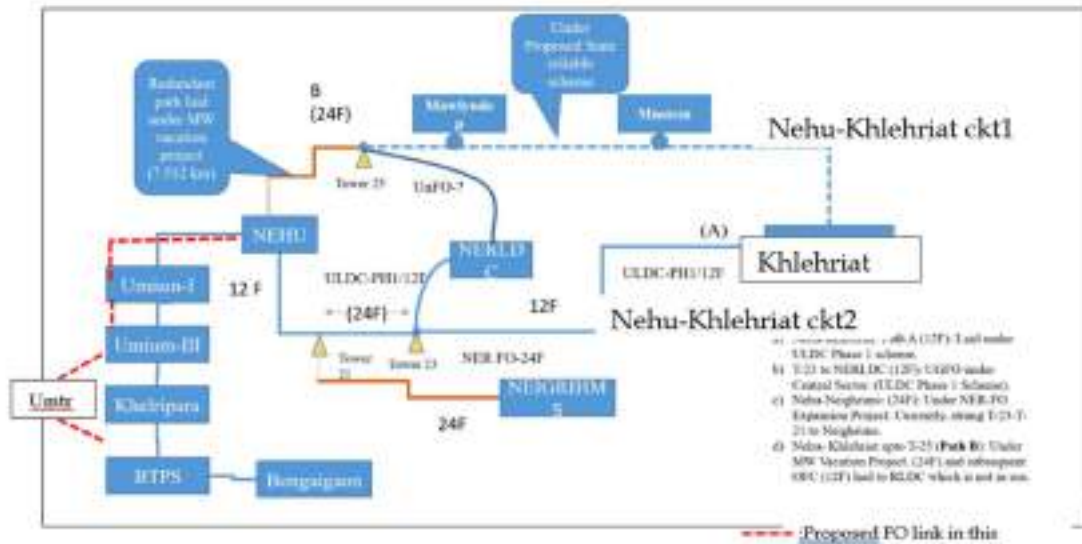

Deliberation of the sub-committee:

The forum agreed with the proposal for replacement of 12F OPGW to 48F OPGW on 132 kV Kahilipara – Umtru - Umiam Stg. III – Umiam Stg. I – NEHU line.

The forum further requested CTU to consider implementation of 48F OPGW on 132 kV Sarusajai – Umtru line as well. This will serve as a redundant path for NERLDC, SLDC Assam and SLDC Meghalaya. CTU will obtain NCT approval for the replacement of 12F to 48F OPGW on 132 kV Kahilipara – Umtru - Umiam Stg. III – Umiam Stg. I – NEHU line. The forum further advised CTU to submit the proposal for implementation of OPGW on 132 kV Sarusajai – Umtru line.

The sub-committee noted as above.

AGENDA FROM AEGCL

2.10. Discussion on requirements of Protection signal status like LBB, Master Trip and over current etc. for the state.

AEGCL has configured the telemetry status of GSS during its upgradation from conventional to SAS. To configure new points again will require support of OEM in phased manners in all the GSS of state. But presently, the total

data reporting across all the GSS of state is little below 70%. As such, these requirements of new signals may be implemented in a phased manner once AEGCLs or STUs current telemetry availability is above 80% and the requirement of new protection signals such as LBB, Master Trip and Over Current etc., should not become mandatory for state as of now.

Deliberation of the sub-committee:

AEGCL highlighted the difficulty of configuring new protection signal status without OEM support to SAS and mentioned that telemetry status is required for FTC of elements. ED, NERLDC proposed to take up the agenda in the next PCC meeting as it involves discussion regarding protection signals. Member Secretary, NERPC advised Assam to implement the new protection signals as per mandate in a phased manner. Assam agreed to implement the same where system/equipment constraint is non-existent.

The sub-committee noted as above.

2.11. Utilization of UNMS for monitoring the communication node percentage availability and sharing the reports with STUs and SLDCs.

Deliberation of the sub-committee:

Assam requested ULDC-POWERGRID to share the availability report of UNMS. Assam and Tripura also enquired about the possibility of downloading the reports from SLDC end.

Member Secretary, NERPC advised ULDC-POWERGRID to share the weekly report of UNMS to all NER SLDCs and also advised ULDC-POWERGRID to explore if there is an option of downloading the reports from SLDC end.

The sub-committee noted as above.

Action: POWERGRID-ULDC

2.12. Planning for installation of RTUs/Redundant Gateways in substation of states where ISTS lines are present.

Deliberation of the sub-committee:

NERPC Secretariat asked the States to share the consolidated list of lines of each State that are connected to ISTS where such redundant path is required. Further discussion shall be taken up in consultation with the States and CTU regarding the same.

The sub-committee noted as above.

132KV Hatsingimari GSS: Recently M/S Sterlite has applied for FTC, but the present GSS do not have redundant Gateway/RTUs and Redundant Communication channels for data reporting to RLDC/SLDC.

Therefore, till the PSDF grants for OPGW and FOTE is sanctioned and as the project is being executed by M/S Sterlite, M/s Sterlite may be requested to arrange redundant PLCC panels (2 nos. - 1 panel at Hatsingimari, 1 panel at Agia) so that redundant communication channel via PLCC can be established from Hatsingimari GSS to 220KV Agia GSS from where OPGW link is available to RLDC/SLDC for proper and reliable data reporting from 132 kV Hatsingimari GSS.

Deliberation of the sub-committee:

Sterlite representative was absent and hence the matter could not be discussed at length. Member Secretary, NERPC advised Sterlite, CTU, Assam and NERLDC to take up a separate meeting and resolve the issue.

The sub-committee noted as above.

2.13. FOTE and DTPC integration and commissioning under NERPSIP

FOTE and DTPC integration and commissioning under NERPSIP is pending in many GSS. There is partial data reporting at 220kV Amingaon and there is issue of non-reporting of data due to flooding of ARP requests at 220 KV Behiating GSS which is intimated to NERPSIP wing but no action has been initiated by NERPSIP wing as of now to mitigate the above issues. Moreover, data of 132 KV Silapathar and 132 KV Tezpur are also not reporting properly due to pending FOTE commissioning.

Deliberation of the sub-committee:

SLDC Assam raised the issue of communication links for the projects commissioned under NERPSIP. POWERGRID-NERPSIP commented that the issue is related to Amingaon, Behaiting, Silapathar and Tezpur and it will be resolved within May, 2024.

The sub-committee noted as above.

AGENDA FROM NERLDC

2.14. Connectivity of NERLDC Guwahati with Sarusajai and Umiam bypassing Kahilipara for its redundancy.

During a meeting held on August 8th, 2022, (MoM is attached as **Annexure-01**) involving Communication-AEGCL, SLDC Assam, NERLDC Grid-India, and ULDC-POWERGRID, several decisions were made. It was agreed that POWERGRID would lay two 24-core fibre optic cables from NERLDC Guwahati to Gantry of Kahilipara. At Gantry, a Joint Box would be installed, facilitating the connection of one cable from NERLDC to the Sarusajai direction and the other cable to the Umtru direction.

Additionally, it was decided that AEGCL would upgrade the existing 12-core Optical Ground Wire (OPGW) over the 132 kV Kahilipara – Sarusajai link to a 24-core OPGW.

During the special meeting dated 7th March 2024, MS, NERPC advised NERLDC to put it as an agenda item in the forthcoming NETeST meeting for further discussion and consideration.

Deliberation of the sub-committee:

The forum requested CTU to consider implementation of 48F OPGW on 132 kV Sarusajai – Umtru line as well. This will serve as a redundant path for NERLDC, SLDC Assam and SLDC Meghalaya. CTU will obtain NCT approval for the replacement of 12F to 48F OPGW on 132 kV Kahilipara – Umtru -

Umiam Stg. III – Umiam Stg. I – NEHU line. The forum further advised CTU to submit the proposal for implementation of OPGW on 132 kV Sarusajai – Umtru line.

AEGCL would upgrade the existing 12-core Optical Ground Wire (OPGW) over the 132 kV Kahilipara – Sarusajai link to a 24-core OPGW. AEGCL proposed to discuss bilaterally with NERLDC regarding AEGCL's scope of work.

The sub-committee noted as above.

2.15. Unauthorised usage of four (04) number of fibers in Panyor – Pare link.

During the restoration of line 132 kV Panyor – Pare line on 26th April 2024, it has come to notice of Sterlite that four (04) number of fibers are unauthorised used. M/s Sterlite has informed via email dated 28th April 2024 attached as **Annexure-02**, the same to NERPC and NERLDC. Out of 12F over 132 kV Panyor – Pare link 4F belongs to Sterlite, 4F belongs to POWERGRID-ULDC and 4F belongs to NEEPCO. POWERGRID-ULDC has informed that they are using Fiber number (3,4) for ULDC network and NEEPCO is using Fiber number (7,8) for differential protection of line. However, it is still not known that which utility is using Fiber number 1,2 and 11,12. NERPC may guide further on what to do in such case.

Deliberation of the sub-committee:

The forum directed Sterlite to back-trace the fiber connection to FODP and find out which devices are connected to the FODP. NERPC also advised Sterlite to carry out Traffic Monitoring of the concerned fibers to ascertain the purpose of the use of the fibers.

The sub-committee noted as above.

2.16. Fiber requirement between Doyang and Sanis for Differential Protection.

In view of enabling the differential protection over 132 kV Doyang-Sanis line, POWERGRID-ULDC is requested to provide 02 number of fibres over 132 kV Doyang-Sanis OPGW which can be used to connect Differential Protection relay.

Deliberation of the sub-committee:

POWERGRID-ULDC requested DoP, Nagaland to give permission for using two number of fibers as the OPGW belongs to the State. POWERGRID-ULDC will deploy the AMC personnel for the connection of relay with the fibers.

The sub-committee noted above.

AGENDA FROM PwC

2.17. SAMAST project related agenda

States	Agenda	Details
Assam	1) Progress status of the project	Warranty support period in progress
	2) Pending payments related to milestone # 2 (Datacenter commissioning) and milestone # 5 (Go-live)	Aging of milestone # 2 invoice is 750+ days and that of milestone#5 invoice is 250+ days. AEGCL is yet to receive 16% of funds.
	3) Annual Maintenance Contract	Warranty period is getting over on 30 th June, 2024. Further services would be stopped post that day without AMC contract.

Meghalaya	1) Progress status of the project	Warranty support period in progress
	2) Pending payments related to milestone # 5 (Go-live)	Aging of milestone# 5 invoice is 250+ days. MePTCL is yet to submit the PSDF requisition for 10% fund
	3) Annual Maintenance Contract	Warranty period is getting over on 30 th June, 2024. Further services would be stopped post that day without AMC contract.
Arunachal Pradesh	1) Progress status of the project	SAT is in progress
	2) Pending payment of milestone # 3 (Factory Acceptance Testing) invoice	Aging of milestone # 3 invoice is 180+ days. Partial payment has been done by DoP, AP. Requisition for 60% fund has been sent to PSDF.
Manipur	1) Progress status of the project	Unavailability of AMR data. Significant impact on SAT schedule
	3) Unavailability of AMR data for Site Acceptance Testing	SAT of Meter Data Management module and Energy Accounting & Settlement module are yet to be initiated due to unavailability of

		significant AMR data. This has a significant impact on SAT schedule.
Mizoram	1) Progress status of the project	SAT and user training have been completed. Waiting for go- live date.
	2) Pending payment of milestone#2 (Datacenter commissioning) and milestone#3 (Factory Acceptance Testing) invoices	Aging of milestone # 3 invoice is 480+ days and milestone # 2 invoice is 400+ days.
Nagaland	1) Progress status of the project	Warranty support period in progress
	2) Pending payment of milestone#2 (Datacenter commissioning), milestone#3 (Factory Acceptance Testing) and milestone # 4 (Site Acceptance Testing) invoices	Aging of milestone # 3 invoice is 440+ days, milestone # 2 invoice is 350+ days and milestone# 4 is 200+ days.
Tripura	1) Progress status of the project	SAT is in progress. Waiting for SAT demonstration date for Energy Accounting and Open Access module from SLDC.
	2) Pending payment of milestone# 3 (Factory Acceptance Testing)	Aging of milestone#3 invoice is 360+ days. Part payment has been done.

Deliberation of the sub-committee:

PwC shared a power point presentation highlighting the status and progress of SAMAST project. They also mentioned the pending payment status of all the States which is highlighted in **Annexure in B 2.17**.

PwC also mentioned about the imminent expiry of AMC for Assam and Meghalaya and stated that renewal of AMC was necessary as no support would be available post expiration. All the States responded that the quoted price for AMC was too high.

After detailed deliberation the forum advised PwC to offer 5 years AMC support with a reasonable price quote which shall be deliberated further by all the States. PwC agreed for the same.

The sub-committee noted as above.

AGENDA FROM MEGHALAYA

2.18. Annual Maintenance Contract (AMC) of SAMAST project

During the 27th NETeST Meeting held on February 21, 2024, at “Hotel Royale de’ Casa”, Guwahati, it was decided to convene a separate meeting regarding the Annual Maintenance Contract (AMC) for the SAMAST project for the states of Assam and Meghalaya. The participants in this meeting would include representatives from SLDC Assam, SLDC Meghalaya, NERLDC, and NERPC.

The SAMAST project was successfully implemented by M/s Genus and M/s PwC, going live on June 30, 2023. The warranty period for the project is nearing completion on June 30, 2024.

We kindly request NERPC’s prompt attention to this matter. To ensure seamless post-warranty support for the SAMAST project, it is crucial to discuss and finalize the Annual Maintenance Contract (AMC) at the earliest.

Deliberation of the sub-committee:

Discussion of Agenda 2.18 from Meghalaya was taken up with Agenda 2.17 from PwC. The forum deliberated and advised PwC to offer 5 years AMC

support with a reasonable price quote which shall be deliberated by all the States. PwC agreed for the same.

The sub-committee noted as above.

3. PART-C: ITEMS FOR UPDATE/FOLLOW-UP

3.1. Project status of NERPSIP and Arunachal Pradesh Comprehensive Scheme

POWERGRID is implementing two number of projects as follows –

- a) North Eastern Region Power System Improvement Project (NERPSIP)** for six (06) States (i.e. Assam, Manipur, Meghalaya, Mizoram, Tripura, and Nagaland) for strengthening of the Intra-State Transmission and Distribution Systems.
- b) Comprehensive Scheme for strengthening of Transmission & Distribution in Arunachal Pradesh**

Deliberation of the sub-committee:

Member Secretary, NERPC opined that a separate meeting is required to review the entire progress of POWERGRID-NERPSIP and POWERGRID-Comprehensive Arunachal Pradesh Scheme.

The sub-committee noted as above.

3.2. Issues related to Maintenance activities of SCADA/EMS system of SLDCs (Agenda A.4 as per MoM of 27th NETeST Meeting)

As agreed on 27th NETeST Meeting, it was decided that NER SLDCs will follow a comprehensive checklist to identify any short-comings during maintenance activities performed by M/S GE T&D India Limited. A sample checklist as shared by NERLDC for the same is attached as **Annexure-03**.

Deliberation of the sub-committee:

The issue could not be discussed as M/S GE T&D India Limited was absent.

The sub-committee noted as above.

3.3. Upgradation Activities of SCADA-EMS systems at Regional/State level in North-Eastern Region (Agenda A.2 as per MoM of 27th NETeST Meeting)

As per the minutes of meeting of 21st PSDF Monitoring Committee held on 17th August 2023, the committee had agreed for the funding of SCADA/EMS project including AMC for the seven (07) NER states and has directed TESC to examine these proposals.

After the meeting held on 22nd November 2023, the modified BoQs along with the signed MoM were sent to CC-Engineering, Grid-India for getting budgetary cost estimate from vendors so that DPR could be revised as per the new cost estimate for onwards submission to PSDF for necessary approval.

Accordingly, CC-Engineering, GRID-INDIA had approached five (5) Vendors viz. M/s L&T, M/s GE, M/s OSI, M/s Siemens & M/s Hitachi seeking budgetary estimates for the SCADA/ EMS Upgradation Project Phase-III (NER) on 9th Feb 2024.

After lots of persuasion, M/s L&T and M/s GE have submitted their quotations for upgradation of SCADA/EMS ULDC Phase III for NERLDC and NER SLDCs to CC-Engineering, GRID-INDIA on 14th Mar 2024 and 09th Apr 2024 respectively.

Subsequently, NERLDC vide mail dated 17th Apr 2024 requested all the NER States for comments on the budgetary estimate and Technical Specification.

NERLDC vide mail dated 30th Apr 2024 and 1st May 2024 sent the respective draft DPR (Part A) to all the NER States.

On 03rd May 2024, a discussion on Detailed Progress Report (DPR) of SCADA/EMS Upgradation Project – ULDC Phase III in North-Eastern Region held via online mode among the NERPC, NERLDC and NER SLDCs. During the meeting, it was agreed by all the states that both the Part A and Part B of the DPRs will be submitted by the respective states to PSDF Secretariat via NERPC at the earliest. MoM of the meeting is attached as **Annexure-4**.

Deliberation of the sub-committee:

NERLDC sent draft DPR of SCADA (part A) along with budgetary estimates to all the NER States on 1st May 2024 and part B of DPR to all the NER States on 10th May 2024. The forum advised all the States to update on the latest status of the DPR (part A and part B).

Arunachal Pradesh: Both part A and part B of DPR is put up for approval from higher authority.

Assam: Both part A and part B are ready and they are waiting for reply on the queries raised by them via mail for the budgetary quote received. NERLDC informed that they would submit the reply within a week's time.

Manipur: part A: submitted for Board approval. part B: Under preparation and will take time.

Meghalaya: Both the parts have been approved and will submit to PSDF.

Mizoram: Raised query regarding any changes in price for part A. NERLDC commented that there was no change in the prices and requested to proceed with the preparation of part A.

part B: The estimate has been completed and formatting is in process, will be submitted in few days.

Nagaland: part A has been completed and put for approval from higher authority. part B: under process.

Tripura:, Waiting for reply on the queries raised by them via mail for the budgetary quote received for part A. NERLDC informed that they would submit the reply within a week's time. Rough budgetary estimate has been obtained for part B. NERLDC requested Tripura to prepare the DPR accordingly.

The sub-committee noted as above.

3.4. Status of State reliable communication scheme (Agenda A.5 as per MoM of 27th NETeST Meeting)

State reliable communication scheme is being funded 90% by PSDF and 10% to be funded by state themselves. As decided in the special meeting held on 09th January 2024, NERLDC has circulated the draft template DPR for “State Reliable Communication Scheme” to all the SLDCs in which entire scope has been divided into 4 parts – Part A (OPGW), Part B (SDH based End Equipment), Part C (VSAT) & Part D (Remote Terminal Units). It was also decided that in case of any state already submitted DPR under “State Reliable Communication Scheme” head to PSDF Secretariat, then also these additional requirements shall be put in form of new DPR and can be submitted under heading “Additional requirements under State Reliable Communication Scheme for real-time data availability strengthening”. The status is tabulated below and states are requested to kindly update further:

Name of State	Status as per 27th NETeST meeting	Current Status
Arunachal Pradesh	<ul style="list-style-type: none"> • DoP-Arunachal Pradesh conveyed the forum that all the state's requirements are being met within the Comprehensive Arunachal Pradesh Transmission and Distribution (T&D) project. • The forum advised a review of the necessity for VSAT installations, particularly at radially connected stations such as Yachuli, Etalin etc. • In this regard, DoP-Arunachal Pradesh informed the forum that many of their generating stations are connected at the 33 kV level for which RTUs and VSATs are required. • The forum noted the same and advised DoP-Arunachal Pradesh to include special requests within the Detailed Project Report (DPR) for the deployment of VSATs and RTUs specifically for monitoring purposes 	Will update via email to NERPC

	at these 33 kV levels generating stations, emphasizing their significance.	
Assam	<p>SLDC, Assam has informed that it has successfully submitted DPR for State reliable Communication Scheme to PSDF for:</p> <ul style="list-style-type: none"> • Part A: Optical Ground Wire (OPGW) • Part B: Synchronous Digital Hierarchy (SDH)-based end equipment • Part C: Very Small Aperture Terminal (VSAT) <p>Forum requested SLDC Assam/AEGCL to share the NLDC specified format of Bills of Quantities (BoQs) which needs to be submitted along with DPR.</p>	Will update via email to NERPC.
Manipur	SLDC, Manipur provided an update to the forum, that they are currently in the process of reviewing their requirements and shall prepare the DPR accordingly.	Will update via email to NERPC
Meghalaya	<ul style="list-style-type: none"> • SLDC, Meghalaya informed the forum that the Detailed Project Report (DPR) encompassing all required components (Part A to Part D) has been completed. • SLDC, Meghalaya further informed that for Fiber Optic Transmission Equipment (FOTE), they have opted for Multiprotocol Label Switching (MPLS) based technology. • However, SLDC, Meghalaya is yet to submit the DPR to the Power System Development Fund (PSDF) due to unresolved issues concerning the 132 kV NEHU-NEIGRIMS, NEHU- NERLDC, and NEHU-Mawlyndep-Mustem-Khliehriat links. 	Will update via email to NERPC .

Mizoram	SLDC, Mizoram informed the forum that the preparation of DPRs for all the parts are in process & they shall submit the same by March'24.	Will update via email to NERPC
Nagaland	<ul style="list-style-type: none"> •DoP, Nagaland informed the forum that according to the decision made during the 32nd Appraisal Committee meeting of PSDF, OPGW with SDH technology has been granted approval in June 2023, with an allocated amount of ₹ 43.05 Crores. •However, DoP-Nagaland, is currently in the process of re-evaluating the necessity for VSAT installations and RTUs for state-owned stations. •They intend to submit any additional requirements in the form of a Detailed Project Report (DPR) by the end of March 2024. 	Will update via email to NERPC
Tripura	The status for SLDC, Tripura could not be updated due to absence of representative from SLDC, Tripura.	Will update via email to NERPC

3.5. Implementation of Guwahati Islanding Scheme (Agenda A.8 as per MoM of 27th NETeST Meeting)

In 27th NETeST meeting, AEGCL informed that Detailed Project Report (DPR) for the Guwahati Islanding Scheme has been formally submitted to the Power System Development Fund (PSDF) for review and consideration. SLDC, Assam also informed that DPR for the communication part shall be submitted shortly.

Deliberation of the sub-committee:

AEGCL informed that DPR for the communication part would be submitted by 3rd week of May'24.

The sub-committee noted as above.

3.6. Non-availability of real-time data pertaining to POWERGRID-owned bays installed at AEGCL-owned stations (Agenda A.11 as per MoM of 27th NETeST Meeting)

It has been observed that the real-time data of POWERGRID-owned bays installed at AEGCL stations are not reporting to NERLDC. These bays have been identified as follows:

Nirjuli bay installed at Gohpur station since 16th Dec-2022.

Silchar bays installed at Srikona station isolator data since 28th Nov -2022.

Silchar bays installed at Hailakandi.

132 kV BNC HVDC bays at Pavoil S/s.

All these bays are ISTS elements, thus data availability is important for real-time drawl calculation and monitoring of ISTS element.

During 27th NETeST meeting, it was decided that as a permanent resolution to the issue, POWERGRID should undertake the upgrade of the aforementioned bays (132 kV Nirjuli bays at Gohpur, 132 kV Silchar Bays at Hailakandi, Silchar bays installed at Srikona and the 132 kV BNC HVDC bays at Pavoil) to Bay Control Unit (BCUs) and subsequently integrate them into the SAS system of AEGCL stations. Whereas, an interim measure for the Silchar bays at Srikona and the 132 kV BNC HVDC bays at Pavoil, the forum requested POWERGRID to reinstate the old Remote Terminal Units (RTUs) with the assistance of AEGCL until permanent upgradation are completed.

Thus, PGCIL is requested to update the status as per the table below:

Sl. No.	Name of Bay	Status of upgrade to BCU and integration to AEGCL SAS (permanent solution)	Latest status (as per 28 th NETeST meeting)
1	Nirjuli bay installed at Gohpur station	<p>The replacement of outdated isolator with new isolators compatibility with the BCU system could not be undertaken due to non-approval/non-availability of shutdown.</p> <p>Action: PGCIL may update the status</p>	<p>BCU upgradation of Nirjuli Bay at Gohpur will be completed by next month.</p>
2	Silchar bays installed at Srikona station	<p>ULDC-POWERGRID informed the forum that they will internally deliberate and communicate the action plan for SAS system upgrades to the forum.</p> <p>Action: PGCIL may update the status</p>	<p>AEGCL requested for CMRs and Cables from PGCIL so that the bay can be integrated in RTU. PGCIL agreed to provide the same. For BCU upgradation</p>

			and integration with SAS, PGCIL-ULDC will talk to PGCIL-AM.
3	Silchar bays installed at Hailakandi.	ULDC-POWERGRID informed the forum that they will internally deliberate and communicate the action plan for SAS system upgrades to the forum. Action: PGCIL may update the status	AEGCL requested for CMRs and Cables from PGCIL so that the bay can be integrated in RTU. PGCIL agreed to provide the same. For BCU upgradation and integration with SAS, PGCIL-ULDC will talk to PGCIL-AM.
4	132 kV BNC HVDC bays at Pavo S/s.	ULDC-POWERGRID informed the forum that they will internally deliberate and communicate the action plan for SAS	AEGCL requested for CMRs and Cables from PGCIL so that the

		<p>system upgrades to the forum.</p> <p>Action: PGCIL may update the status</p>	<p>bay can be integrated in RTU. PGCIL agreed to provide the same. For BCU upgradation and integration with SAS, PGCIL-ULDC will talk to PGCIL-AM.</p>
--	--	--	--

The sub-committee noted as above.

3.7. Connectivity of 132 kV Khupi S/s with ULDC network (As per MoM Point A.12 of 27th NETeST Meeting)

Comprehensive-POWERGRID & DoP-Arunchal Pradesh are requested to update the following:

- a. Stringing in 03 nos. spans are yet to be completed due to damage to the towers' leg of AP-157 and AP-158. DoP, Arunachal Pradesh has been informed of the damage. DoP, Arunachal Pradesh may update the timeline for restoration of damaged towers.
- b. LILO at Tenga: Comprehensive-PGCIL has confirmed the OPGW of the LILO portion is completed by Devi Energies Pvt. Ltd. The splicing of the LILO portion with the Khupi-Balipara link will be finalized upon the completion of stringing from AP-157 to AP-158 tower. Additionally, Comprehensive-PGCIL has informed that SDH equipment for the 132 kV

Tenga and Dikshi Hydroelectric Power (HEP) projects will be procured, installed and commissioned under Comprehensive-Arunachal Pradesh T&D.

Deliberation of the sub-committee:

For Part (a) :DoP, Arunachal Pradesh informed that fund has been sanctioned from Government of Arunachal Pradesh. The work shall be completed by December-2024.

For Part (b): DoP, Arunachal Pradesh informed that LILO work is dependent on tower rectification work. This part shall be executed only after completion of Part (a).

The sub-committee noted as above.

3.8. Cyber Security aspects in SCADA/IT systems at Load Despatch Centres in North Eastern Region (Agenda A.13 as per MoM of 27th NETeST Meeting)

State-Utilities may update the status with respect to CII Status by NCIIPC, ISO 27001:2013 implementation, VA-PT twice a year, Cyber Crisis Management Plan (CCMP), Cyber Management Team (CMT), patching of vulnerabilities and virus alerts from CERT-In/CERT-GO, etc, participation in various trainings and workshops on Cyber Security being conducted by CEA, Ministry of Power and Grid-India, etc.

During 27th NETeST meeting, all the SLDCs were advised to expedite the fulfilment of all aspects related to cybersecurity promptly. Emphasizing the integration of OT with the SAMAST, NERLDC stressed the imperative adoption of requisite measures to ensure a secure IT-OT connection. States have affirmed their compliance with the approved architecture in accordance with cybersecurity guidelines and decisions made within various NERPC forums.

A summary of the present status of each SLDC is attached in as **Annexure-6.**

Deliberation of the sub-committee:

NERLDC highlighted the present status of cyber security aspects in SCADA/IT systems at each SLDC. A summary of the present status of each SLDC is attached in as **Annexure-C3.8**. Member Secretary advised all state to made their IT/OT system under cyber compliant and set up SOC at all SLDC through PSDF funding at the earliest.

The sub-committee noted as above.

3.9. Concerned regarding shifting of SLDC Arunachal Pradesh from old building to new building (Agenda A.14 as per MoM of 27th NETeST Meeting)

It is learnt that SLDC Arunachal Pradesh has completed its new control centre building, which is nearby to exiting SLDC building (Chimpu S/s). However, following are concerns from NERLDC:

- a. Plan for shifting of SCADA/EMS system from old building to new building.
- b. Plan for shifting VoIP exchange also.
- c. Plan for shifting of various communication links of Comprehensive-AP, ULDC and Powertel links (fibre & FOTE) to new building.

In 25th NETeST meeting, DoP, Arunachal Pradesh informed that the discussion is being held with M/s GE T&D for shifting the SCADA/EMS system from old premises to new premises. NERLDC emphasized that along with SCADA/EMS, plan for shifting of VoIP exchange and communication links (POWERTEL, ULDC and Comprehensive- AP) should also be prepared well in advance. Member Secretary, NERPC advised DoP, Arunachal Pradesh to plan the activities with minimal outage. DoP, Arunachal Pradesh informed the forum that the matter is in initial discussion phase and further brainstorming would be done on it before presenting it to the forum.

In 26th NETeST meeting, SLDC Arunachal Pradesh informed the forum that the discussion is being held with M/s GE T&D for shifting the SCADA/EMS system from old premises to new premises & accordingly Techno-commercial offer was sought, which is yet to be furnished by M/s GE. M/s GE agreed to expedite the matter & requested SLDC Arunachal Pradesh to forward the mail to sales team of M/s GE T&D once. GE has reminded on the same email for DoP-AP confirmation with copy to NERPC for information.

In the special meeting held on 10th January, 2024, SLDC, Arunachal Pradesh & M/s GE were advised to bilaterally discuss the issues.

In 27th NETeST meeting, SLDC, Arunachal Pradesh & M/s GE were advised to bilaterally discuss and resolve the issues.

Deliberation of the sub-committee:

DoP Arunachal Pradesh informed that the process is still in progress.

The sub-committee noted as above.

3.10. Restoration of OPGW owned by Manipur (Agenda A.15 as per MoM of 27th NETeST Meeting)

It has been noticed that seven stations i.e., 132 kV Chandel, 132 kV Churachandpur, 132 kV Hundung, 132 kV Kakching, and 132 kV Kongba of Manipur are not reporting due to outage of 132 kV Churachandpur – Ningthoukhong OPGW link. It was reported that there is a break in the Optical Ground Wire (OPGW) approximately eight (08) Kilometers from the 132 kV Ningthoukhong Substation. However, the rectification work could not be undertaken as The subjected OPGW installation was done by POWERGRID-ULDC under NER-FO. Incomplete Handing over documents (absence of signatures by PGCIL executives) was furnished by POWERGRID to SLDC, Manipur on 06th April 2021. SLDC Manipur has requested ULDC-POWERGRID to sign the documents on 11th December 2023. SLDC Manipur has conveyed that proper documentation is essential for addressing the issue. The forum requested POWERGRID furnish complete handing over document.

Deliberation of the sub-committee:

POWERGRID-ULDC informed that in a meeting with Managing Director, MSPCL, Manipur had requested POWERGRID to complete the entire task. However, the financial aspects of the work were not discussed with MSPCL. Member Secretary, NERPC advised POWERGRID and MSPCL to discuss the issue bilaterally.

The sub-committee noted as above.

3.11. Establishment of redundant fibre path between NERLDC and NEHU for reliability of power system communication link till RLDC. (As per MoM Point A.17 of 27th NETeST Meeting and as per MoM of Special Meeting held on 7th Mar 2024)

A. After detailed deliberation on 7th Mar 2024 (MoM is attached as **Annexure-7**), the forum agreed to the following for 132 kV NEHU-Mawlyndep-Mustem-Khliehriat line (subject to approval of TCC/RPC Forum):

- a) 48F OPGW from NEHU to Khliehriat: MePTCL to propose 48F OPGW on 132 kV NEHU-Mawlyndep-Mustem-Khliehriat line (132 kV NEHU – Khliehriat CKT-II) under the State reliable communication Scheme or other suitable schemes. MePTCL to lay and subsequently maintain the link as well.

Action: For information and necessary action of MePTCL

- b) From T-25 to NERLDC: POWERGRID-ULDC to lay and maintain the underground 48F cable under the ongoing reliable communication scheme out of which 24F will be connected to NEHU and the balance 24F to be connected with Mawlyndep. Further, approval shall be taken in the forthcoming TCC/RPC meeting for upgrading the approved 24F to 48F.

Action: For Information and Necessary action of

POWERGRID-ULDC

- c) Establishment redundant links to NERLDC, Shillong: The Forum requested POWERGRID-ULDC to survey and check the feasibility of establishing redundant links to NERLDC, Shillong via 400 kV Silchar- Byrnihat Line and 220 kV New Shillong S/s.

Action: POWERGRID-ULDC may update the status

- B.** After detailed deliberation on 7th Mar 2024, the forum agreed to the following for 132 kV NEHU – Khliehriat CKT-I (subject to approval of TCC/RPC Forum):

- a) Completion of Useful Life: NERLDC informed the forum that 12F OPGW between NEHU to Khliehriat was laid in ULDC Phase-1 and it has completed its useful life of 15 years. As such replacement of the same has become essential.

Action: For Information

- b) 48F OPGW from NEHU to Khliehriat: The Forum suggested that the OPGW should be upgraded to 48F by POWERGRID in consultation with CTU.

Action: POWERGRID-ULDC may update the status

- c) From T-23 to NERLDC: 12F Underground cable will be upgraded to 24F cable which is already part of the Reliable communication scheme.

Action: POWERGRID-ULDC may update the status

- d) From T-23 to NEIGRIHMS: 24F OPGW is already laid under the NER FO scheme which will be connected to NEHU and Khliehriat.

Action: POWERGRID-ULDC may update the status

- e) The proposed distribution of the fiber shall be as follows:

Sl. No.	From	To	Number of Fiber
1	NEHU	Khleihriat	24F
2	NEHU	NERLDC	12F
3	NERLDC	Khleihriat	24F
4	NEHU	NEIGRHIMS	12F
5	NEIGRHIMS	Khleihriat	12F

Action: For Information

- f) CEA has constituted a committee under the chairmanship of Member (Power System), CEA for formulating comprehensive guidelines for the usage and sharing of optical fibers (OPGW) for power system applications. NER will follow the guidelines approved by the committee.

Action: For Information

Deliberation of the sub-committee:

This agenda was taken up along with Agenda 2.8.

NERLDC mentioned that 132 kV NEHU -Khlehriat(PG) link (bold line in diagram) is designated as circuit 1 and 132 kV NEHU-Khlehriat(PG) link (dotted line in diagram) is circuit 2. The forum decided to rename 132 kV NEHU – Khleihriat ckt 1 to 132 kV NEHU – NEIGRIHMS – Khleihriat line.

CTU will take NCT approval of 48F OPGW of 132 kV NEHU – NEIGRIHMS – Khleihriat line and of 48F UG from Tower 25 of 132 kV NEHU – Mawlyndep line to NERLDC.

Communication link from Tower-23 to NERLDC is already part of the Reliable communication Scheme and is already approved. ULDC – POWERGRID

informed that PwD Meghalaya clearance has been obtained for laying 24F UG Cable from Tower 23 of 132 kV NEHU – NEIGRIHMS line to NERLDC.

132 kV NEHU-Mawlyndep-Mustem-Khliehriat line (132 kV NEHU – Khliehriat CKT-II) is under the State reliable communication Scheme of Meghalaya.

The sub-committee noted as above.

3.12. Replacement of FO link for “NERLDC Shillong – NEHU”, “132 kV Kahilipara– Sarusajai” and “132 kV Kahilipara – Umiam Stg. III – Umiam Stg. I – NEHU”. (As per MoM Point A.18 of 27th NETeST Meeting and as per MoM of Special Meeting held on 7th Mar 2024)

After detailed deliberation on 7th Mar 2024, the following have been decided.

- a) Replacement of FO link for “132 kV Kahilipara – Sarusajai” – The forum noted that as this AEGCL’s section is not vital for NERLDC connectivity so replacement and maintenance of OPGW on this section shall be considered by State/STU.
- b) Replacement of FO link for “132 kV Kahilipara – Umiam Stg. III – Umiam Stg. I – NEHU” – CTUIL via email informed that as per the discussion held in 5th CPM meeting of CTUIL, it was suggested in the forum that 48 fibers may be laid and maintained by POWERGRID on Meghalaya owned lines “132 kV Kahilipara – Umiam Stg. III – Umiam Stg. I – NEHU”. Out of 48 fibers, 24 fibers will be for ISTS use and the rest 24 fibers for state purpose. This was agreed in the forum. However, Meghalaya stated that they will have to take consent from their management for the said proposal.

Meghalaya (MePTCL) informed that their management has approved the laying and maintenance of 48 fibers by POWERGRID in “132 kV Kahilipara – Umiam Stg. III – Umiam Stg. I – NEHU” subject to the use of 24 fibers for ULDC/System requirement and balance for their own commercial purpose. However, POWERGRID opined that the usage and

sharing of the fibers is to be done as per CEA/CERC guidelines/regulations.

Additionally, MePTCL has made a request to connect the 132 kV Kahilipara – Umiam Stage III line at 132 kV Umtru for improved connectivity. The forum agreed to the same and endorsed the establishment of the link as 132 kV Kahilipara – Umtru - Umiam Stg. III – Umiam Stg. I – NEHU. Further discussions regarding the distribution of OPGW between ULDC-POWERGRID and MePTCL to take place in subsequent meetings.

AEGCL highlighted the critical nature of the 132 kV Kahilipara – Umtru OPGW link for Assam, NERLDC, and Meghalaya. AEGCL requested that the OPGW over the 132 kV Sarusajai – Umtru line to be considered as a redundant path. The forum has acknowledged the same and decided to deliberate on it in forthcoming meetings.

Deliberation of the sub-committee

This agenda was already deliberated with Agenda 2.9.

The sub-committee noted as above.

3.13. Status of Fiber-Optic works under different projects (As per MoM Point B.2 of 27th NETeST)

S. No.	Link name	Utilities which may respond	As per 27 th NETeST	Latest Status
I. Fiber Optic Expansion Projects				
Meghalaya State Sector				
1	132kV NEHU - NEIGRIMS	POWERGRID-NERTS	Matter was discussed in special meeting held on 07 th March 2024.	Taken up in Agenda 2.8

S. No.	Link name	Utilities which may respond	As per 27 th NETeST	Latest Status
Central Sector				
2	400kV Bongaigaon (PG) - 220kV Salakati - 220kV BTPS	POWERGRID-NERTS	Stringing will start from March'24	No response has been obtained from Chinese vendor M/S SDJI. The matter is under process and POWERGRID will resolve it at the earliest.
3	400kV Mirza (Azara) - Byrnihat (Killing)		<ul style="list-style-type: none"> 27/47 KMs is completed. Rest will be completed by March'24. 	No response has been obtained from Chinese vendor M/S SDJI. The matter is under process and POWERGRID will resolve it at the earliest.
4	400kV Silchar - Palatana		<ul style="list-style-type: none"> Stringing completed. Unhealthy stretch of 25-30 KM requires replacement. Contract for replacement of 	Survey going on for unhealthy stretch. Work will commence after availability of

S. No.	Link name	Utilities which may respond	As per 27 th NETeST	Latest Status
			unhealthy part is allotted. • Work will by end of March'24. Action: POWERGRID-NERTS may update the status.	materials on site.
Manipur State Sector				
5	132kV Imphal (State) – Karong	MSPCL and POWERGRID	Five (05) KMs of stringing is pending which will be completed by March'24. Action: MSPCL and POWERGRID-NERTS may update the status.	Completed

3.14. Status and details of Fiber-Optic projects approved in 17th TCC/RPC meeting (As per MoM point B.3 of 27th NETeST)

A. Additional Communication Scheme: During the 27th NETeST meeting, forum advised POWERGRID-ULDC the commissioning of links is pending for more than three months for lack of installation of FOTE which could have been avoided. Status as per 27th NETeST meeting (attached as **Annexure 8_A**).

Action: POWERGRID-ULDC may update the status.

Deliberation of the sub committee

POWERGRID-ULDC updated the status as Annexure 8A

B. Reliable Communication Scheme:

- a. Replacement of existing fibre: Status as per 27th NETeST is attached as **Annexure-8_B**.

Action: POWERGRID-ULDC may update the status.

- b. Fibre on new lines: Status as per 27th NETeST is attached as **Annexure-8_B**.

Action: POWERGRID-ULDC may update the status.

Deliberation of the sub committee

POWERGRID-ULDC updated the status as Annexure 8B

3.15. Integration of Dikshi HEP real time data and pending Voice communication (Agenda B.4 as per MoM of 27th NETeST)

As per 27th NETeST meeting, DoP, Arunachal Pradesh assured the forum that the matter shall be resolved by the next NETeST meeting.

DoP-AP informed that the matter shall be resolved by May-2024.

3.16. Automatic Generation Control (AGC) in Indian Grid (Agenda B.5 as per MoM of 27th NETeST)

The status could not be updated in 27th NETeST due to absence of representative from OTPC & NEEPCO

Station Name	Background	Status as per 27th NETeST Meeting	Latest status
AGBPP (Kathalguri)	OEM visits was envisaged as per following –	Four number of Mitsubishi-make GTs:	Tendering is in process.

Station Name	Background	Status as per 27th NETeST Meeting	Latest status
	<p>Some units are of Mitsubishi make which require team from Japan to visit plant.</p> <p>Other units are of GE-make and BHEL-make</p>	<p>Mitsubishi informed that they will only report site once AGC panel for BHEL-GE make GTs are successfully commissioned.</p> <p>Two number of BHEL & GE-make GTs:</p> <p>Technical specification (TS) for RTU of AGC RTU prepared. Tender to be floated within Dec'23. (as per 26th NETeST meeting).</p> <p>The status could not be updated in 27th NETeST due to absence of representative from NEEPCO.</p>	

Station Name	Background	Status as per 27th NETeST Meeting	Latest status
		Action: NEEPCO may update the status.	
Doyang	NEEPCO may update the status	<p>Preparation of Technical Specification SCADA & AGC is under process. Once completed shall be floated for tendering. (as per 26th NETeST meeting).</p> <p>The status could not be updated in 27th NETeST due to absence of representative from NEEPCO.</p> <p>Action: NEEPCO may update the status.</p>	Tender for SCADA floated. Bidder has requested for extension from NEEPCO. NEEPCO informed that the work completion schedule is 33 weeks from the issuance of LoA.
Kopili Stage -2	25 MW	NLDC has been informed that the unit is ready to be taken into service for AGC.	Will be done after Khandong comes into service.

Station Name	Background	Status as per 27th NETeST Meeting	Latest status
		For information to the forum	
Kopili	100W	<p>Station commissioning will be completed in the month of March'24. AGC shall be implemented after that only. (as per 26th NETeST meeting).</p> <p>The status could not be updated in 27th NETeST due to absence of representative from NEEPCO.</p> <p>Action: NEEPCO may update the status.</p>	Unit 1 shall be available by May 2024.
Khandong	As per new Ancillary Services Regulation 2022, all ISGS plant will be participating in AGC.	Plant will be commissioned on July'25. AGC will be commissioned after that only. (as per 26th NETeST meeting).	Shall be completed by July-2025.

Station Name	Background	Status as per 27th NETeST Meeting	Latest status
		<p>The status could not be updated in 27th NETeST due to absence of representative from NEEPCO.</p> <p>Action: NEEPCO may update the status.</p>	
Kameng	As per new Ancillary Services Regulation 2022, all ISGS plant will be participating in AGC.	<p>The status could not be updated due to absence of representative from NEEPCO.</p> <p>Action: NEEPCO may update the status.</p>	In process. Petition filed to CERC for exemption. Deliberations going on with NEEPCO management
Ranganadi (Panyor)	As per new Ancillary Services Regulation 2022, all ISGS plant will be participating in AGC.	<p>The status could not be updated due to absence of representative from NEEPCO.</p> <p>Action: NEEPCO may update the status.</p>	In process. Petition filed to CERC for exemption. Deliberations going on with NEEPCO management
Pare	As per new Ancillary Services Regulation 2022, all ISGS plant will	The status could not be updated in 27th NETeST due to absence of	In process. Petition filed to CERC for exemption.

Station Name	Background	Status as per 27th NETeST Meeting	Latest status
	be participating in AGC.	representative from NEEPCO. Action: NEEPCO may update the status.	Deliberations going on with NEEPCO management
RC Nagar	As per new Ancillary Services Regulation 2022, all ISGS plant will be participating in AGC.	The status could not be updated in 27th NETeST due to absence of representative from NEEPCO. Action: NEEPCO may update the status.	There is constraint due to low gas supply, will be discussed in OCC forum.
Palatana	As per new Ancillary Services Regulation 2022, all ISGS plant will be participating in AGC.	The status could not be updated in 27th NETeST due to absence of representative from OTPC. Action: OTPC may update the status.	OTPC was absent.

The sub-committee noted as above.

3.17. Pending issues of State Utilities of NER (Agenda B.6 as per MoM of 27th NETeST)

The status as per 27th NETeST Meeting is given below:

Utility	Pending issues	Remarks
Assam	SAS upgradation related works may be updated.	Dullavchera is not reporting. Assam-SLDC informed that there is issue of SAS gateway, which is expected to be completed by March'24.
Tripura	Dharmanagar	Discussion could not be carried out due to absence of Tripura representative.
	Ambassa	
Manipur	Chandel, Churachandpur, Rengpang, Tipaimukh, and Yiangangpokpi	<ul style="list-style-type: none"> The mentioned stations are not reporting. MSPCL informed that they have started restoring the RTUs but it may take time due to current law and order situation.
	Hundung, Yurembam, Kakching, Konga and Ningthoukhong	<ul style="list-style-type: none"> The mentioned stations are reporting partially. MSPCL informed that they have started restoring the RTUs but it may take time due to current law and order situation.
	Elangkhangpokpi, Thanlon, 132kV Thoubal, 132 kv Moreh	<ul style="list-style-type: none"> MSPCL has proposed the purchase of RTUs under PSDF.
Nagaland	Kiphire	<ul style="list-style-type: none"> Meluri-Kohima line is still under diversion due to road construction work. PLCC is restored, DoP will visit the station to restore the data at the earliest. DoP-Nagaland informed that they have submitted the cost estimate NHIDL for shifting of tower and waiting for their response.
Mizoram	Luangmual	<ul style="list-style-type: none"> Communication equipment at Lungmual is powered off due to repeated incident in which cards of SDH/PDH were burnt. It is suspected that SDH/PDH are not connected properly to earth. PE&D-Mizoram informed that survey for restoration of isolator data has been done and proposal to restore the
	Zuangtui	
	Kolasib	

		data will be submitted sooner.
Arunachal Pradesh	VSAT installation and other issues	<p>UPS installation for VSAT equipment:</p> <ul style="list-style-type: none"> DoP, Arunachal Pradesh informed that UPS installation is completed in Along, Deomali and Pasighat. For Daporizo the UPS is supplied but installation is pending. <p>RTU failure at Daporijo:</p> <p>Discussion could not be carried out due absence of M/s GE T&D representative.</p> <p>Power Supply issue at Pasighat:</p> <ul style="list-style-type: none"> 48V to 110V DC Converter is faulty, same has been purchased and issue shall be resolved soon
Meghalaya	Non reporting of stations	<ul style="list-style-type: none"> 220 kV Mawngap is now reporting

The states shall update the latest status and concerns via email to NERPC.

The sub-committee noted as above.

3.18. Feasibility to connect Lekhi Substation over Fiber-Optic Network (Agenda B.7 as per MoM of 27th NETeST Meeting)

During 25th NETeST meeting, POWERGRID informed the forum that SDH equipment has been diverted from Monarchak and the same shall be installed by 15th June, 2023. POWERGRID requested DoP, Arunachal Pradesh to provide space for installation & they have agreed to provide the same. POWERGRID also informed that due to DCPS issue, presently they were using DC convertor. DoP, Arunachal Pradesh agreed to look into the matter. During 26th NETeST meeting, POWERGRID-ULDC informed the forum that new SDH is proposed under NER Reliable communication scheme. Currently the DC converter of Lekhi S/s is not working due to which Lekhi PDH is not powered up and thus not reporting to SLDC Arunachal Pradesh

over fiber network. DoP-AP is requested to update on the status for providing space DCPS. POWERGRID is requested to update on the status for installation of the DCPS.

During 27th NETeST meeting, DoP-AP informed that space for installation of DCPS will be provided.

Currently, DC converter of Lekhi is not working due to which Lekhi is not connected over OPGW network. POWERGRID-ULDC is requested to restore the DC converter as an interim measure till the new SDH and DCPS are installed.

Deliberation of the sub-committee:

POWERGRID informed that they had taken up the matter with vendor M/s Tejas for the supply of DC converter. The work shall be included under the NER reliable communication scheme.

The sub-committee noted as above.

Annexure-I**List of Participants in 28th NETeST meeting held on 14.05.2024 at NERPC Conference Hall, Shillong**

Sl No.	Name	Organisation	Contact
1	Sh. K.B Jagtap, Member Secretary	NERPC	8652776033
2	Sh. Anil Kawrani, Director	NERPC	8799737377
3	Smt. Maya Kumari, DD	NERPC	9462692814
4	Sh. Alikpantha De, DD	NERPC	9681932906
5	Sh. Ashim Kumar Goswami, AD	NERPC	8638966481
6	Sh. S.K Rajim Ali, Associate Director	PwC	9674352414
7	Sh. Azizur Rahman, Partner	PwC	9818523366
8	Sh. Sriram Potluri, Director	PwC	9909909584
9	Sh. Arnab Pratim Das, ED	PwC	9830087811
10	Sh. Vineet Kumar,GM	PGCIL	9720168941
11	Sh. Prasanta Kumar Das, DGM	Comprehensive	9436700725
12	Sh. A.K Verma,DGM	NERPSIP	8894701248
13	Sh. Joypal Roy,CGM	NEEPCO	8837200069
14	Sh. Palash Jyoti Borah, Manager	NERLDC	8761093397
15	Sh. Sakal Deep, AM	NERLDC	9774528218
16	Sh. Saugato Mondal, GM	NERLDC	9433041885
17	Sh. Amaresh Mallick, ED	NERLDC	9436302720
18	Sh. K.K Medhi, Sr. GM	PGCIL	6901261814
19	Sh. K. Baishya, AM	PGCIL	9859723132
20	Sh. Bhaskar Gohain, JE	PGCIL	9401244599
21	Sh. Pankaj Bikash Sarmah, AGM	APGCL	9435358402
22	Sh. Jyotirmoy Das, AM	AEGCL	8402938215
23	Sh. Rupjyoti Das, DM	AEGCL, SLDC	9435097009
24	Sh. Nilotpall Bhattacharjee, AM	AEGCL, SLDC	7044376443
25	Sh. Mriganka Bhuyan, AGM	AEGCL, SLDC	9101302916
26	Sh. Arup Sarma, AGM	AEGCL	9707854367
27	Sh. Anup Kumar Das, Engineer	Genus	7005723719
28	Sh. Wenon Narhawang, JE	MePTCL	8787840514
29	Sh. Gordon Mawniuh, FS	MePGCL	9366353917
30	Sh. Kaushal Suman, Chief Manager	CTUIL	7042396702
31	Smt. Shampa Sen, SM	TPTL,SLDC	9436120263
32	Sh. Geyi Yinko, JE	DoP,AP	9436200050
33	Sh. S.W Khyriem, AEE	MePGCL	8787396704
34	Sh. Y. Saikai, AEE	SLDC, Meghalaya	9402133552

35	Sh. M.K War, EE	SLDC, Meghalaya	9774012496
36	Sh. Lalawmpuia, AE	SLDC, Mizoram	8730843706
37	Sh. V. Lalhmingliana, JE	SLDC, Mizoram	9774724873
38	Sh. Imsubenla Pongen, JE	SLDC, Nagaland	9774724873
39	Sh. E. Pongmei Phoni, SDO	SLDC, Nagaland	8132862504
40	Sh. Saptarshi Deb, Manager	Genus	8420472769
41	Sh. Kumar Akash, AM	Genus	9523309580
42	Sh. N.J Sharma, RM(East)	Genus	9330623701

**GUIDELINES
ON
AVAILABILITY OF COMMUNICATION SYSTEMS**

Prepared in Compliance

To

Central Electricity Regulatory Commission

(Communication System for inter-State transmission of electricity)

Regulations, 2017

January 2024

GUIDELINES ON AVAILABILITY OF COMMUNICATION SYSTEM

1. INTRODUCTION:

1.1 As per Regulation 7.3 of the Central Electricity Regulatory Commission (Communication System for inter-State transmission of Electricity), Regulations, 2017, National Power Committee (NPC) has been entrusted to prepare Guidelines on Availability of Communication System in consultation with RPCs, RLDCs, CTU and other stakeholders. Accordingly, these Guidelines have been prepared for determining Availability of Communication System.

1.2 The relevant provisions in the Central Electricity Authority (Technical Standards for Connectivity to the Grid), Regulations, 2007, CEA (Technical Standards for Communication System in Power System Operations) Regulations, 2020 and CERC (Indian Electricity Grid Code) Regulations, 2023 in respect of Communication System are as follows:

1.2.1 **Regulation 6(3) of the CEA (Technical Standards for Connectivity to the Grid)** stipulates that *'the requester and user shall provide necessary facilities for voice and data communication and transfer of online operational data, such as voltage, frequency, line flows and status of breaker and isolator position and other parameters as prescribed by the appropriate load dispatch centre.'*

1.2.2 **Regulation 5(1) of the CEA (Technical Standards for Communication System in Power System Operations) Regulations, 2020** stipulates that user shall be capable of transmitting all operational data as required by appropriate control centre.

1.2.3 **Regulation 11 of the Indian Electricity Grid Code (IEGC) 2023 stipulates as follows:**

"11. DATA AND COMMUNICATION FACILITIES (1) Reliable speech and data communication systems shall be provided to facilitate necessary communication, data exchange, supervision and control of the grid by the NLDC, RLDC and SLDC in accordance with the CERC (Communication System for inter-State Transmission of Electricity) Regulations, 2017 and the CEA Technical Standards for Communication.

(2) The associated communication system to facilitate data flow up to appropriate data collection point on CTU system including inter-operability requirements shall also be established by the concerned user as specified by CTU in the Connectivity Agreement.

(3) All users, STU and participating entities in case of cross-border trade shall provide, in coordination with CTU, the required facilities at their respective ends as specified in the connectivity agreement. The communication system along with data links provided for speech and real time data communication shall be monitored in real time by all users, CTU, STU, SLDC and RLDC to ensure high reliability of the communication links.”

2. DEFINITION:

2.1 Words and expressions used in these guidelines shall have the same meaning assigned in the Electricity Act, Central Electricity Authority (Technical Standards for Connectivity to the Grid) Regulation ,2007, CEA (Technical Standards for Communication System in Power System Operation) Regulations, 2020, CERC (Communication System for Inter-State transmission of Electricity), Regulations, 2017 and Indian Electricity Grid Code Regulations, 2023 and amendments thereof.

2.2 Other words have been explained as per the context in these Guidelines.

3. SCOPE AND APPLICABILITY:

3.1 As per Regulation 5 (i) of the CERC (Communication System for inter-State transmission of Electricity), Regulations, 2017, *“These regulations shall apply to the communication infrastructure to be used for data communication and tele -protection for the power system at National, Regional and inter-State level and shall also include the power system at the State level till appropriate regulation on Communication is framed by the respective State Electricity Regulatory Commissions.”*

3.2 Accordingly, these guidelines shall be applicable to the CTU for the Communication System Infrastructure of inter-State Transmission System. The guidelines shall also be applicable to STU for the Communication System Infrastructure of intra-State Transmission System, till appropriate regulation on Communication is framed by the respective State Electricity Regulatory Commission.

3.3 The CTU (or STU as the case may be) shall have back to back co-ordination/agreement with transmission licensees, generators, dedicated transmission line owners, bulk consumers and concerned entities for providing power system communication on their network.

3.4 Responsibility of CTU and STU:

- a) CTU (or STU as the case may be) shall be responsible for submission of the details of communication channels including the redundant channels configured for use of voice / data / video exchange, protection, Tele-protection / SPS to respective RLDC (SLDC as the case may be) on monthly basis incorporating the details of new channels configured during previous month. The total number of communication channels (N) is based on the requirement of RLDCs/NLDC and the same would be decided in consultation with respective RPCs/NPC.
- b) CTU (or STU as the case may be) shall be responsible for submission of the performance/availability of configured channels of the previous month to respective RLDCs for verification by RLDCs and onward submission to respective RPC for computation of availability of the communication system for previous month.
- c) CTU (or STU as the case may be) shall submit availability reports of configured channel including the redundant channels in format prescribed by RLDC/RPC, generated from the centralized NMS. The availability report of the call logging facility (with time stamp) may be provided till commissioning of centralized NMS for availability computation.

4. TREATMENT OF COMMUNICATION SYSTEM OUTAGES:

- 4.1 Outage time of communication system elements (i.e. channels) due to acts of God and force majeure events beyond the control of the communication provider shall be considered deemed available. However, onus of satisfying the Member Secretary, RPC that element outage was due to aforesaid events shall rest with the communication provider.
- 4.2 Any outage of duration more than one (01) minute in a time-block shall be considered as not available for the whole time-block. Any outage of duration less than or equal to one (01) minute in a time-block shall be treated as deemed available provided such outages are not more than ten (10) times in a day.

Illustration: If a channel is out for a duration less than or equal to one (01) minute in a time-block, and such outages are more than ten (10) times in a day, all the time-blocks with such outages shall be treated as not available.

4.3 All other outages not covered under 4.1 and 4.2 shall be considered as not available during the whole block for the computation of channel availability.

5. METHODOLOGY FOR COMPUTATION OF AVAILABILITY OF COMMUNICATION SYSTEM:

5.1 Availability of Communication System (**A_{CS}**) shall be calculated as under:

$$A_{CS} = \frac{\sum_{i=1}^N A_i}{N}$$

Where - **N** is total number of communication channels as specified in 3.4(a) above.
 - **A_i** is Availability of *ith* Channel which shall be calculated as given in 5.2 below.

5.2 Availability of *ith* Channel (**A_i**) shall be arrived as under:

$$A_i = \frac{B_T - B_{Ni}}{B_T} \times 100$$

Where **B_T** is Total number of time-blocks in a month

B_{Ni} is the total number of time-blocks, in which *ith* channel was not available after considering deemed availability status of 4.1 & 4.2 above.

$$B_{Ni} = B_{ANi} - B_{Gi} - B_{LTTi}$$

Where-**B_{ANi}** is absolute number of time-blocks in which the *ith* channel was 'not available' on account of any reason.

-**B_{Gi}** is Number of time-blocks out of **B_{ANi}**, in which *ith* channel was 'not available' on account of act of God as specified in 4.1 above.

-**B_{LTTi}** is Number of time-blocks out of **B_{ANi}**, in which *ith* channel was 'not available' for a duration less than or equal to one (01) minute in a time-block and not more than ten (10) times in a day as specified in 4.2 above.

Illustrations:

Case1: If there are 2880 time-blocks (**B_T**) in a month, and a particular channel is not available for a total of 70 time-blocks; and out of this, the above mentioned channel was not available for 20 (**B_{Gi}**) time-blocks due to act of God, six (06) time-blocks for less than one (01) minute (**B_{LTTi}**), then **B_{ANi}**=70, **B_{LTTi}** =06, **B_{Ni}** =70-20-06 = 44, and **A_i** = (2880-44)/2880 = 98.47%

Case 2: If there are 2880 time-blocks (**B_T**) in a month, and a particular channel is not available for a total of 70 time-blocks; and out of this, the above mentioned channel was not

available for 20 (B_{Gi}) time-blocks due to act of God, 11 time-blocks for less than 1 minute, then $B_{ANi}=70$, $B_{LTTi} = 0$, $B_{Ni}=70-20-0=50$, and $A_i = (2880-50)/2880 = 98.26\%$.

6. Revision of these Guidelines

6.1 As and when required, these Guidelines shall be reviewed and revised by NPC with the approval of the Commission.

Annexure B.2.2

Final Standard Operating Procedure (SOP) for Communication audit of Substations

1. This procedure has been prepared in compliance to Central Electricity Regulatory Commission (Communication System for inter-State transmission of electricity) Regulations, 2017. As per clause 10 of the Regulation, RPC shall conduct annual audit of the communication system annually as per the procedure finalized in the forum of the concerned RPC. However, this SOP for communication audit of substations is finalized to maintain uniformity at the national level. It also mandates that RPC Secretariat shall issue necessary instructions to all stakeholders to comply with the audit requirements within the time stipulated by the RPC Secretariat based on the audit report. An Annual Report on the audit carried out by respective RPC is to be submitted to the Commission within one month of closing of the financial year.
2. The Audit would be conducted in two phases. In first phase scrutiny of the reports, documents etc. In the second phase physical verification shall be carried out.
3. Each User/entity, using inter-state transmission or the intra-state transmission incidental to inter-state, shall submit the detailed report to RPC Secretariat and RLDC, as per prescribed format on yearly basis. The detailed report shall be submitted by the April end of the respective year. This report shall be considered as self-certificate regarding availability and healthiness of the Communication system of respective user/entity.
4. In respect of intra-state users/entities, SLDC shall submit detailed reports yearly by the April end of the respective year, to RPC Secretariat and RLDC.
5. Outage report of all the channels (including Network Management System, PLCC etc) report for a month shall be submitted by the Users/entities to RLDC and respective SLDCs, on monthly basis, by 7th day of the next month. RLDC and SLDCs after verifying the NMS data shall submit report to RPC Secretariat by 15th day.
6. All users/entities and Control Centers shall get the third-party cyber security audits done from a Cert-in certified vendor in compliance of CEA (Cyber Security in Power Sector) Guidelines,2021. The detailed report of the Cyber Security Audit shall be submitted by 15th April for the previous financial Year.
7. RPC Secretariat may ask any other information required for Audit of the communication system in addition to these periodic reports.

Phase-I Audit: Scrutiny of the Information

8. A Communication System Audit Sub-Group comprising one member each from RPC, RLDC, PowerGrid and One of the respective Region SLDCs shall be constituted by RPC Secretariat with the approval of Member Secretary, RPC. The sub-group may co-opt any other member from any organization for facilitating the activities of the sub-group. Further, consultation from CEA may be taken, if required. The Audit team shall be formed excluding the member for the Organization/Utility whose system is to be audited.
9. The Communication System Audit Sub-group shall scrutinize the information received in RPC Secretariat. The Sub-group may also ask any additional information necessary for its activities. All the users/entities, RLDC, SLDCs shall provide the information to the sub-group on priority within the stipulated time period.
10. The sub-group shall also identify the nodes for physical inspection based on the criticality of the node in view of performance of the communication network or based on the deficiencies observed in the communication system.
11. The Audit would include but not limited to following aspects:
 - a. Availability of communication channels. The outage reason needs to be clearly specified whether it is on account of the concerned entity or on account of any other entity, force majeure etc. The list of communication channels would be finalized by Communication System Sub Group in consultation with other stakeholders.
 - b. Availability of terminal equipment. The outage reason needs to be clearly specified whether it is on account of the concerned entity or on account of any other entity, force majeure etc. The list of terminal equipment would be finalized by Communication System Sub Group. Part outage like failure of specific cards etc. would also be furnished along-with reasons.
 - c. Availability of Auxiliary System e.g. Battery Charger, Battery bank, sufficient cooling equipment etc.
 - d. Compliance of CERC and CEA Regulations and the procedures under these Regulations.
 - e. Completion of periodic testing of the communication system in accordance with procedure for maintenance and testing prepared by CTU.
 - f. Audit of all newly commissioned communication equipment within six months of its commissioning.
 - g. Completion of 3rd party Cyber Security Audits.
 - h. Network traffic w.r.t capacity.
 - i. Spare availability, replenishment etc.
 - j. Any other parameters as agreed by the Communication Sub Group.

Phase-II Audit: Physical Verification

12. Based on the Recommendations of the Communication System Audit Sub-group, Audit team shall be constituted and the physical inspection Audit plan shall be prepared by RPC Secretariat.
13. Audit team shall be formed on regional basis.
14. Audit shall be carried out in a planned manner as included in this document by a team of three members. The audit team shall comprise of one representative from the RPC Secretariat, one representative from RLDC and one representative from any of the Utilities or SLDCs of respective Region. The Audit team shall be formed excluding the member for the Organization/Utility whose system is to be Audited. The Audit team may co-opt any other member from any organization for facilitating the activities of the committee.
15. Once the plan is finalized, minimum 3 days advance notice shall be served to the concerned Auditee entity intimating the detailed plan so that availability of required testing equipment and the required documents is ensured by Auditee entity and is made available to the Audit team during the site visit.
16. Member Secretary, RPC in consultation with the Communication System Audit Sub-Group may decide on any additional nodes/locations for physical inspection if a location is very critical in view of performance of the communication network at any time of the year.
17. The Scope of the physical verification shall include but not limited to the following:
 - a. Available communication Network for its redundancy
 - b. Availability of channel redundancy for all the functions for which it is configured.
 - c. Communication equipment (hardware and software configuration) of all the nodes including repeater stations for its recommended performance.
 - d. Documentation of the configuration of the respective site and its updation.
 - e. Fibre layout / usage of fibre / Availability of dark fibre and its healthiness.
 - f. Cable Schedule and identification / tagging.
 - g. Healthiness of Auxiliary supply including the healthiness of Battery backup.
 - h. Healthiness of Earthing / Earth protection for communication system.
 - i. Availability of sufficient cooling equipment at the User's premises to maintain the stipulated temperature for the communication equipment.
 - j. Optical power level
 - k. Alternate modes of communication for speech
18. The format for collecting the details of Communication channels/links and Equipment is at **Annexure-I** and the same shall be furnished by the Auditee entity.

19. Communication Audit Checklist points are given in **Annexure-II** and the same are to be thoroughly verified by the Audit team.
20. Expenses towards Lodging, Boarding & Transportation (Excluding Air/Train Fair) between various places within the jurisdiction of Auditee entity shall be borne by respective Auditee entity. The Coordinating Officer(s) from the Auditee Utilities identified for each Team is (are) responsible for facilitating them to all the Members of respective Team.
21. Audit team shall submit report including recommendations for action on deficiencies, if any, found during the inspection, within 15 days from the date of inspection to Member Secretary, RPC. After approval of MS, RPC, the report would be communicated to the Auditee entity for compliance.

Audit Compliance Monitoring

22. Communication System Audit Sub-group would monitor the compliance of audit observations as applicable. Non-compliance of Audit Recommendations, if any, shall be put up to TCC and RPC.
23. The Annual Audit Report would be reviewed by a Communication System Sub Group at RPCs level. After considering the observations of Sub Group, RPC Secretariat shall issue necessary instructions to all stakeholders to comply with the audit requirements within the time stipulated by the RPC Secretariat based on the audit report. An Annual Report on the audit carried out by RPC would be submitted to the Commission within one month of closing of the financial year.

REGIONAL COMMUNICATION AUDIT REPORT			
General Information:			
1	Substation Name		
2	SS Voltage level		
3	Date of commissioning of the substation	XX.XX.XXXX	
4	Region & State / Auditee	/	
5	Audit Date		
6	Name of the Utility which owns the SS		
Details of Audit Team Members :			
SL	Name	Designation	Organization
1			
2			
3			
4			
Attached Documents, if any			
SL	Name of the document	Original / Signed / Copy	
1			
2			
3			
4			
5			
6			
7			

8		
9		
10		
11		
12		
13		
14		
15		
16		
17		

Communication Channels and Equipments Audit Format

(A) List of channels in usage for data (64 kbps, 104, PMU, VC, 101) / Voice / Protection circuits / others:

SI	Description (64 kbps, 104, PMU, VC, 101) / Voice / Protection circuits / Others)	Source	Destination	Channel Routing	Ownership details of terminal equipment / Links
1					
2					
3					
4					
5					
6					
7					
8					

(B) List of terminal communication equipments:

SI	Name of Station	Equipment Type (SDH / PDH / Radio / VSAT / EPABX)	Make / Model	Ownership
1				
2				
3				
4				
5				
6				
7				
8				

(C) Communication System Details:

I. SDH Equipment

(1) Card Details:

Slot No	IP Address & Path / Direction Name	Card Details	Place a ✓ mark if on usage, else Write as "Spare"	Whether Card is healthy / Faulty ? (H / F)	Cards Redundancy available (Yes / No)	Power Supply Card / Optical Card (Yes / No)	MSP configured? (Yes / No)	Action Plan for faulty cards	Other Information, if any
1									
2									
3									
And so on									

(2) Whether equipment is time synchronized : Yes / No

If Yes, how is it being done?

(3) Failures during last Fin. year / since last Audit :

Particulars	Number of failures of Card / Power Supply	Reason for failures	Measures taken for rectification
Card		(i) (ii) (iii)	(i) (ii) (iii)
Power Supply		(i) (ii) (iii)	(i) (ii) (iii)

(4) Configuration of the Node:

Name of Equipment	Number of Nodes	Number of directions	Name of Directions	Number of links down, with details	Details of corrective action, if any, taken

--	--	--	--	--	--

(5) Preventive maintenance schedule and its compliance:

Date of Last Preventive maintenance	Maintenance carried out as per schedule? (Yes / No)	Whether all the defects have been attended? (Yes / No) Give details

II. PDH Equipment

(1) Card Details :

Slot No	IP Address	Card Details	Place a ✓ mark if on usage, else Write as "Spare"	Whether Card is healthy / Faulty ? (H / F)	Cards Redundancy available (Yes / No)	Power Supply Card / Optical Card (Yes / No)	MSP configured? (Yes / No)	Action Plan for faulty cards	Other Information, if any
1									
2									
3									
And so on									

(2) Whether equipment is time synchronized : Yes / No

If Yes, how is it being done?

(3) Failures during last Fin. year / since last Audit :

Particulars	Number of failures of Card / Power Supply	Reason for failures	Measures taken for rectification
Card		(i) (ii)	(i) (ii)

		(iii)	(iii)
Power Supply		(i) (ii) (iii)	(i) (ii) (iii)

(4) Configuration of the Node:

Name of Equipment	Number of Nodes	Number of directions	Name of Directions	Number of links down, with details	Details of corrective action, if any, taken

(5) Preventive maintenance schedule and its compliance:

Date of Last Preventive maintenance	Maintenance carried out as per schedule? (Yes / No)	Whether all the defects have been attended? (Yes / No) Give details

III. OPGW / Optical Fibre Details

Number of Directions	Name of Direction	No. of Pairs	No. of Fibers used	No. of spare & healthy Fibers	Unarmoured cable laid within PVC/Hume duct pipe?	Fibre Count in OPGW? Whether matching with Approach cable to FODP?	Overall Optical Fibre Path Attenuation (dB/km)	Power Received	Conformation to Compliance of CEA Standards

IV. Healthiness of Auxiliary System:

(1) Details of 2 independent Power Sources :

VIII. Radio Communication Details:

Number of Equipments	Make and Model	Status on Healthiness	Last preventive maintenance		Details of defects, if any, attended	Status of Availability of Spares	Conformation to Compliance of CEA Standards
			Schedule	Actual			

IX. Data Retention : (i) **Earliest Date of availability of data:** _____
(ii) **Historical data availability** : _____ days.

X. Control Command Delay : (i) **Time delay in seconds from Control Centre for SCADA** : _____ Seconds
(ii) **Time delay in seconds from Control Centre for WAMS** : _____ Seconds

XI. Wide Band Network : (i) **Absolute channel delay in protection applications** : _____ ms
(ii) **Channel delay asymmetry in protection applications** : _____ ms
(iii) **Switching Time delay to alternate path/route during failure of one path** : _____ ms

XII. Any other information :

Audit Team Member
SRPC

Audit Team Member
Co-Ordinator

Audit Team Member
PGCIL (Internal / External)

Audit Team Member
State (Internal / External)

Communication Audit Checklist (Annexure-II)

S.No	Check list points	Expected	Actual	Reference
1	Whether OPGW is terminated properly. Down lead shall be fixed properly in sufficient locations. Metallic part shall be connected to earth mat riser.	Yes		
2	Distinct approach cable shall be laid 1 Protection & Communication 2 Fibers for commercial applications Item no 1 cable shall be terminated in communication room FODP One number FODP panel shall be available in communication room			
3	Fiber Identification shall be done in FODP properly			
4	Whether End to end tests were carried out during installation and records are available (both Optical Power Source/receiver test and OTDR Test results)			
5	Whether patch chords 1 Cross labelled (source/ receive) 2 Tx – Rx Marking 3 Mechanical protection is provided for patch chords laid between panels			
6	Whether separate room for communication is available with following:- 1 Air conditioning with standby A/C Unit 2 AC Distribution board with ELCB 3 Single point earthing bar which shall be connected to substation Earth mat			
7	Two sets of 48 V (Positive Earthed) DC System shall be available with 1 Common DC Distribution board/ Panels with incoming MCB, coupler MCB , out doing MCB setc 2. Minimum 200 Ah (2 sets of battery) VRLA batteries are preferred to keep chargers and battery in communication room. 3. Battery Charger shall be Thyristorised/SMPS			
8	Battery Charger alarms /measurements shall be made available to SAS (if available) It can be achieved through MOD bus or connecting analogue/ digital signals to Common BCU of SAS. If such system is not available major			

Communication Audit Checklist (Annexure-II)

	alarms shall be alarmed in common substation annunciator			
9	2 nos of substation Data (From RTU or SAS Gateway) shall route in different roots to Main and Standby Load Dispatch centres			
10	Kindly assure proper protection is available for AC Distribution (ELCB, MCB, Backup fuse),			
11	Aux Transformer neutral Earthing shall be connected to Stations earth mat (Aux Transformers shall be installed in yard earth mat area only)			
12	Whether DG sets with AMF panels are provided for Aux AC Supply			
13	Whether 2 nos 11 kV (or 33kV) supplies are available for Each station aux Transformer			

Annexure B.2.3

Final Standard Operating Procedure (SoP) for Communication System Outage Planning

1. As per the following CEA and CERC Regulations, the Communication Outage for the Region shall be carried out by RPC Secretariat:

a) Regulation 7.3 of Central Electricity Regulatory Commission (Communication System for inter-State transmission of electricity) Regulations, 2017 stipulates as below:

Quote:

7.3 Role of National Power Committee (NPC) and Regional Power Committee (RPC):

.....
(iv) The RPC Secretariat shall be responsible for outage planning for communication system in its region. RPC Secretariat shall process outage planning such that uninterrupted communication system is ensured.
.....

Unquote

b) Regulation 10 Central Electricity Authority (Technical Standards for Communication System in Power System Operations) Regulations, 2020 notified on 27.02.2020 envisages as below:

Quote:

10. Outage Planning: Monthly outage shall be planned and got approved by the owner of communication equipment in the concerned regional power committee, as per detailed procedure finalized by the respective regional power committee.

Unquote

2. A Communication System Outage Planning Sub-Group/ TeST Sub Committee shall be formed in each region constituting the members from all the entities connected to ISTS including all CGS, ISGS, REGs/SPPDs/SPDs, STUs, SLDCs etc., of the respective Region, RLDC/Grid-India, PGCIL, CTUIL, Private Transmission licensees in respective region & RPC secretariat. The sub-group/ Sub Committee may co-opt any other member from any organization for facilitating the activities of the sub-group/ Sub Committee.

3. Communication System Outage Planning will be limited to the following systems:

- (i) ISTS Communication System including ISGS
- (ii) Intra-state Communication System being utilized for ISTS Communication
- (iii) ICCP links between Main & Backup RLDCs, Main & Backup SLDCs & Main & Backup NLDCs.
- (iv) Inter-regional AGC links.

- (v) Any other system agreed by the sub-group.
4. Communication Equipment/link within the scope of the Procedure would include :
- (i) Optic Fibre links
 - (ii) Any other link being used for ISTS communication
 - (iii) ICCP links between Main & Backup RLDCs, Main & Backup SLDCs & Main & Backup NLDC
 - (iv) VC links between LDCs
 - (v) Inter-regional AGC links
 - (vi) SPS Links
 - (vii) Tele-Protection
 - (viii) AMR
 - (ix) PMU
 - (x) SDH & PDH
 - (xi) DCPC
 - (xii) RTU & its CMU cards
 - (xiii) DTPCs
 - (xiv) Battery Banks and Charging Equipment
 - (xv) EPABX
 - (xvi) Any other equipment/link agreed by the sub-group
5. A Web Portal named as “Communication System Outage Planning Portal” shall be developed by respective RLDCs. Log-in credentials shall be provided to all the ISTS connected entities/concerned entities.
6. Entities/Users/Owners shall add their communication links and the equipment to the Web Portal as soon as they are commissioned. The same has to be furnished to RPC Secretariat /RLDCs.
7. Entities/Users/Owners of the communication equipment shall upload the outage proposals of communication links and the equipment (in the prescribed format only) to be availed during subsequent month by 7th/8th of every month in the Web Portal.
8. RPC Secretariat consolidates the list of outage proposals received from various Entities/Users/Owners of the communication links and equipment by downloading from the Web portal and circulate the same among all the respective region entities by 15th of every month. Communication outages affecting other regions would be coordinated by respective RLDC through NLDC.
9. Communication System Outage Planning (CSOP) meeting shall be conducted during the third week of every month normally (preferably through VC) to discuss and approve the proposed outages of communication links and equipment.
10. The approved outages of Communication links and equipment in the CSOP meeting shall be published in the RPC website and respective RPCs Communication Outage Portal within 3 days from the date of CSOP meeting.

11. Outage of the approved communication links and equipment shall be availed by the respective owner /entities after confirming the same with RLDC on D-3 basis.
12. In case of any emergency outage requirement of communication links and equipment, Entities/Users/Owners may directly apply to respective RLDC with intimation to respective RPCs on D-2 basis. Confirmation of approval/rejection will be provided on D-1 basis by RLDCs in consultation with respective RPCs considering 24hrs processing window.
13. Entities/Users/Owners shall take the code from the respective RLDC before availing the planned outage of the communication links & equipment and before restoration of the same.
14. Entities/Users/Owners of the communication links and equipment shall submit the deviation report for the approved outages (approved dates & approved period) availed during the previous month and the report on planned / forced / other outage of communication links / equipment by 10th of the month to RPC Secretariat as per the format at **Annexure-I** .
15. In the monthly CSOP meetings, communication links and equipment whose outage duration (Planned / Forced / Others) more than 48 hours for the last 12 months of rolling period shall be deliberated for the measures to be taken in future for the better outage management. The date deviations and non-availing the outages that were approved in the previous CSOP meetings shall also be deliberated in the CSOP meetings.

Comprehensive T&D-Arunachal Pradesh and NERPSIP. Map is required because many stations mentioned in the scheme above are connected with existing ISTS/ISGS nodes.

NERLDC had provide the necessary details of Comprehensive T&D-Arunachal Pradesh and NERPSIP to CTUIL via email dated 23rd June 2023.

CTUIL is requested to update about the preparation of the communication map.

Members may deliberate.

Deliberations: As per point number 3.0 above.

5.0 VSAT project for North-Eastern Region (by NERLDC)

Considering the various geographical factors, technological factors and successful pilot projects, it was decided in various NERPC forums that a special project of VSAT technology will be envisaged for all NER states. Subsequently, DPR was submitted by each state and put up to Techno-economic Sub-group (TSEG) committee of PSDF secretariat, where it was deliberated to put the OPGW and VSAT in same DPR on request of CTUIL.

CTUIL is requested not to keep OPGW and VSAT technology as part of same DPR.

Members may deliberate.

Deliberations:

GRID-INDIA stated that DPR of VSAT and OPGW for PSDF funding should not be combined as suggested in recent TSEG group meeting. Forum agreed that both technologies are completely different. GRID-INDIA further stated that the tenders of VSAT and OPGW are never clubbed together and vendors handling the two technologies of communication are separate with different expertise. The VSAT technology has been tested on Extended-C band in pilot projects conducted in NER and the same is under operation in around 13 nos. of stations (incl. 3 stations of POWERGRID) located in Arunachal Pradesh. The approvals for adoption of this technology had already been taken in TCC/NERPC Board meeting held in March 2022 at Guwahati. In order to analyse the matter further, CTU requested GRID-INDIA to share minutes of meeting of the TSEG held in March-2023 and CTU will revert after getting the details. GRID-INDIA agreed to provide the same.

6.0 Additional FOTE at all AGC operated generating stations in North Eastern region, in view of resource disjoint and criticality of AGC operation for grid operation purpose (by NERLDC)

Additional FOTE at all AGC operated generating stations in North Eastern region, in view of resource disjoint and criticality of AGC operation for grid operation purpose. Failure or single equipment may lead to disruption in AGC operation.

Following AGC Locations may be considered for additional FOTE:

- a. Bongaigaon – AGC Operational
- b. Loktak – AGC Operational
- c. Kopili – AGC under implementation
- d. Khandong – AGC under implementation
- e. Kopili Stage 2 – AGC under implementation
- f. Kathalguri – AGC under implementation

- g. Doyang HEP – AGC under implementation
Members may deliberate.

Deliberations: GRID-INDIA informed the forum that five nos. of new AGC stations as stated above are planned for implementing the AGC in NE Region as per CERC order and these stations shall be operational for AGC in next three to four months tentatively. Accordingly, FOTE redundancy may also be planned. Mizoram told that it is not confirmed whether AGC shall be implemented or not at Doyang HEP. GRID-India stated that these stations are approved as per CERC order; however, they will re-check and confirm during discussion of agenda in NETeST meeting. POWERGRID shared the equipment requirement for redundancy as follows via email dated-04/08/23 as below:

Kopili – No

Khandong -No

Kopili stage 2 -No (In the said meeting, it is informed that Kopili stage 2 and Khandong are in same premises. Therefore, Kopili stage 2 is considered as Khandong).

Kathalguri – No (At present only 1 SDH is PRESENT. However, 1 no. is upcoming under Kathalguri – Namsai (NERXV))

Doyang – Yes

Accordingly one FOTE for Doyang-HEP is required for AGC operation .The agenda shall be put up in RPC TeST for review.

7.0 OPGW Connectivity of 220 kV Zahdima (Nagaland/State node) to 400/220 kV New Kohima (KMTL/ISTS node) (by NERLDC)

DoP Nagaland is constructing 220/132 kV Zahdima substation which will be connected with 400/220 kV (KMTL/ISTS node) over 220 kV Transmission line being constructed by State. It has come to notice that OPGW is not envisaged in the Transmission line.

Forum may discuss about the possibility of considering the OPGW over the 220 KV Zahdima – New Kohima transmission line.

Members may deliberate.

Deliberations: POWERGRID informed that 220KV Zahdima- New Kohima transmission line is a state-sector line and for laying OPGW on this line, ISTS approval of NCT is required. CTU clarified that for laying OPGW on state-sector lines under ISTS, it should be utilized for ISTS communication. Further for the same, agreement of owner state and all other stakeholders is required. The agenda shall be further discussed in NERPC meeting in presence of DoP-Nagaland and other states.

Meeting ended with a vote of thanks from CTUIL.

--XX--

Minutes of 26th NETeST Meeting held on 10th October, 2023

This agenda was deliberated in 25th NETeST meeting held on 25.05.2023 wherein the forum advised CTUIL to inform the critical node identified by PGCIL/CTU to the forum.

CTU has identified few SPOF nodes such as Bongaigaon, Melriat, Imphal and Dimapur. POWERGRID may confirm status of redundant FOTE and Power Supply at these nodes.

Further, any other SPOF nodes may be suggested by members.

Deliberation of the sub-Committee:

POWERGRID informed that 1 no. FOTE & 1 no. Power Supply is available at Bongaigaon, Melriat, Imphal and Dimapur. However redundant FOTE and Power Supply at Melriat & Imphal may not be useful as the exiting network utilization is around 10% and 20% respectively. After detailed deliberation, the forum opined that due to space/cost, FOTE level redundancy is not recommended. The forum requested CTU to identify to alternate links/route to these SPOF.

The Sub-Committee noted as above.

Action: CTU

A.21 Additional FOTE at AGC locations

Additional FOTE at all AGC operated generating stations in North Eastern region is required in view of resource disjoint and criticality of AGC operation for grid operation purpose as failure of single equipment may lead to disruption in AGC operation. Further, at many locations redundant ethernet port are not available as per NLDC requirement. The NLDC requirement is as follows:

- 1+1 Ethernet port for main NLDC
- 1+1 Ethernet ports are for backup NLDC

This is to be deliberated for additional FOTE and ports/cards at AGC locations.

Following AGC Locations may be considered for additional FOTE:

- a) Kopili – AGC under implementation
- b) Khandong – AGC under implementation
- c) Kopili Stage 2 – AGC under implementation
- d) Kathalguri – AGC under implementation
- e) Doyang HEP – AGC under implementation

Deliberations in 4th CPM: GRID-INDIA informed the forum that five nos. of new AGC stations as stated above are planned for implementing the AGC in NE Region as per CERC order and these stations shall be operational for AGC in next three to four months tentatively. Accordingly, FOTE redundancy may also be planned.

POWERGRID shared the FOTE equipment requirement for redundancy as follows via email dated-04/08/23 as below:

- **Kopili** – No
- **Khandong** -No
- **Kopili stage 2** -No (In the said meeting, it is informed that Kopili stage 2 and Khandong are in same premises. Therefore, Kopili stage 2 is considered as Khandong).
- **Kathalguri** – No (At present only 1 SDH is PRESENT. However, 1 no. is upcoming under Kathalguri – Namsai (NERXV)
- **Doyang** – Yes

Accordingly, one FOTE for Doyang-HEP is required for AGC operation.

Deliberation of the sub-Committee:

NERLDC informed the forum that as per CERC Ancillary Regulation, 2022 Subhansiri (Upcoming NHPC Plant), Kameng (NEEPCO) and Palatana (OTPC) also qualifies for AGC implementation. Thus, additional FOTE should be considered for Subhanshiri (Upcoming NHPC Plant), Kameng (NEEPCO), Palatana (OTPC) and Doyang-HEP.

The Sub-Committee noted as above.

Action: CTU

A.22 Connectivity of STU node on fibre in view of AMR.

The meter readings from several locations (mostly STU nodes) (list of location shall be provided by Grid-India) in each region are intermittent and having communication issues as the meters at the state nodes are not having secure & reliable communication links and are operational on public domain communication links like GPRS. It is proposed to provide the connectivity of such nodes on captive OPGW network for receiving the data successfully for AMR purpose.

Grid-India has identified a list of such nodes (list attached as **Annexure A.22**) for each region.

The line length (for the STU nodes as listed in **Annexure A.22**) from STU node to nearest ISTS node may be provided by Grid-India/STU/State constituent along with line name, line ownership so as to prepare a scheme for OPGW laying. Based on the inputs received, the scheme shall be made and put up for approval in NCT.

After detailed deliberation the forum recommends PSDF Secretariat to reconsider the sanctioned amount in view of the higher price discovery during procurement.

TCC recommended for approval of RPC.

Deliberation of the RPC

The RPC noted and approved the recommendation of TCC.

ITEM NO. B.11	:	STRENGTHENING OF LAST MILE FIBER-OPTIC CONNECTIVITY TO OBTAIN BETTER RELIABILITY AT NERLDC, SHILLONG AND BACKUP NERLDC, GUWAHATI: - NERLDC
---------------	---	---

NERLDC, Shillong is currently connected to 132 kV NEHU (MeECL) sub-station over fiber-optic media which is more than 15 years old and has crossed its lifespan leading to deterioration of associated optical-fibers. Since the optical-fiber carries important real-time power system operational data and voice; hence, the fiber-optic should be replaced between “NEHU and NERLDC Shillong (partially overhead and partially underground) preferably with a 2x24-fiber redundant arrangement”.

Similarly, Backup NERLDC at Kahilipara, Guwahati is connected over OPGW of 132 kV Kahilipara-Sarusajai and 132kV Kahilipara – Umiam Stg. III – Umiam Stg. I – NEHU which is a twelve (12) fiber link and same has exceeded its life-span of 15 years since its installation under ULDC Phase-1 scheme. In order to maintain reliability of communication system at mission-critical establishment of NERLDC as well as regional communication backbone network, it will be beneficial to replace the OPGW on above-mentioned lines with at least twenty-four (24) fibres.

As several OPGW projects in NER are already under tendering/execution stage by POWERGRID; hence, the aforesaid links can be included in such projects (i.e., NER Reliable Communication Scheme or other similar projects or any new project, as per feasibility by POWERGRID) for faster completion.

TCC/NERPC may kindly approve the replacement of three sections namely “NERLDC Shillong – NEHU”, “132 kV Kahilipara – Sarusajai” and “132 kV Kahilipara – Umiam Stg. III – Umiam Stg. I – NEHU” under any of the POWERGRID projects (such as NER

Reliable Communication Scheme or other similar projects or any new project, as per feasibility by POWERGRID) being executed by ULDC team of POWERGRID-NERTS.

Deliberation of the TCC

AGM, AEGCL informed that the OPGW links are very old and has reached EOL thus may be replaced ASAP.

Sr.GM, CTUIL informed that as per MoP notification all communication proposal shall need to be approved by NCT. After NCT approval the same shall be accommodated under suitable project. Further, he stated in all Regions it is common practice to check healthiness of fibers every 6 months. So, all links healthiness may be periodically provided to CTU, whereupon unhealthy links can be replaced irrespective of the life of the fiber.

ED, NERLDC stated that procedure needs to be followed, so TCC may recommend for replacement. After detailed deliberation the forum recommended for replacement of OPGW with 24 Fiber and referred the same to NCT (substantiated with test report) after RPC approval.

Director (Trans), MePTCL noted that commercial issues need to be considered and requested for clarity on Revenue Sharing mechanism.

TCC recommended for approval of RPC.

Deliberation of the RPC

The RPC noted and approved the recommendation of TCC.

ITEM NO. B.12 : FIBER CONNECTIVITY FOR CRITICAL CENTRAL-SECTOR TAIL-END GENERATING STATIONS: - NERLDC
--

Some of the generating stations currently connected over single fiber-optic link are as follows –

a) Kameng Hydro Station (600 MW): Currently, fiber-optic connectivity is being done with 400 kV Kameng-Balipara OPGW only. It may be noted that OPGW works of 132 kV Kameng-Khupi are already under progress; hence, in order to establish physical redundancy for establishing secondary communication channel of Kameng, an OPGW should be laid over 132 kV Khupi – Tenga – Balipara section also. Kindly refer to the **Annexure-B.12** for details.

B. Follow up agenda items

B.1:Agenda to be deliberated

1)Replacement of FO link for “NERLDC Shillong – NEHU”, “132 kV Kahilipara – Sarusajai” and “132 kV Kahilipara – Umiam Stg. III – Umiam Stg. I – NEHU”.

POSOCO stated that in the 23rd TCC and NERPC meeting, TCC forum recommended for replacement of OPGW with 24 Fiber for NERLDC Shillong – NEHU”, “132 kV Kahilipara – Sarusajai” and “132 kV Kahilipara – Umiam Stg. III – Umiam Stg. I – NEHU” after RPC and NCT approval. This proposal for replacement shall be substantiated with test report of fiber healthiness. But test report is not available with Meghalaya SLDC as the links have not been handed over to them by POWERGRID. POWERGRID stated that automatic handing over of the link ownership takes place after completion of fifteen years.

Further deliberations were held regarding ownership and maintenance of the said links.

CTUIL stated that since these links are being used for ISTS data & voice communication and this communication shall be kept intact. In view of this CTU requested POWERGRID to clarify the entity who is maintaining the above said lines.

Deliberations in the 4th CPM: POWERGRID told that this link contains critical ISTS data and this is the only path for NERLDC connectivity with only 12 Fibers. POWERGRID shared the connectivity diagram of NERLDC (as shown in figure below) and explained the criticality of these links. POWERGRID told that if Meghalaya is ready to maintain and takeover the link they have no issue in handing over these links.

However, GRID-INDIA informed that one of the above links i.e 132 kV Kahilipara – Sarusajai section belongs to Assam which is not vital for NERLDC connectivity and replacement of OPGW on this link shall be considered separately in consultation with Assam. Further, GRID-INDIA stated that 132kV NEHU-Umiam-I-Umiam -III is critical for Grid operation as most of the NERLDC data and AGC data is being routed through this path. In view of this, GRID-INDIA requested CTU for approval for laying of OPGW on these lines to be obtained from NCT. CTU suggested OPGW replacement on all these links may be carried out by single party considering reliability of backbone connectivity to NERLDC. CTU clarified that for approval of OPGW replacement on these lines under ISTS scheme from NCT, the replacement of OPGW shall be substantiated with test report of fiber healthiness which was asked for in the 23rd TCC and NERPC meeting also.

POWERGRID also intimated that Meghalaya is also implementing OPGW on Khleiriat-NEHU section which provides path redundancy for NERLDC. CTU suggested POWERGRID to check whether 48 Fibers can be laid on the “NERLDC Shillong – NEHU” and “132 kV Kahilipara – Umiam Stg. III – Umiam Stg. I – NEHU” paths so that fibers can be shared for ISTS and STU

purposes. CTU requested POWERGRID to provide test-report of fiber healthiness of these links so that further review/approval in NETeST/TCC/NERPC & subsequently NCT may be taken up.

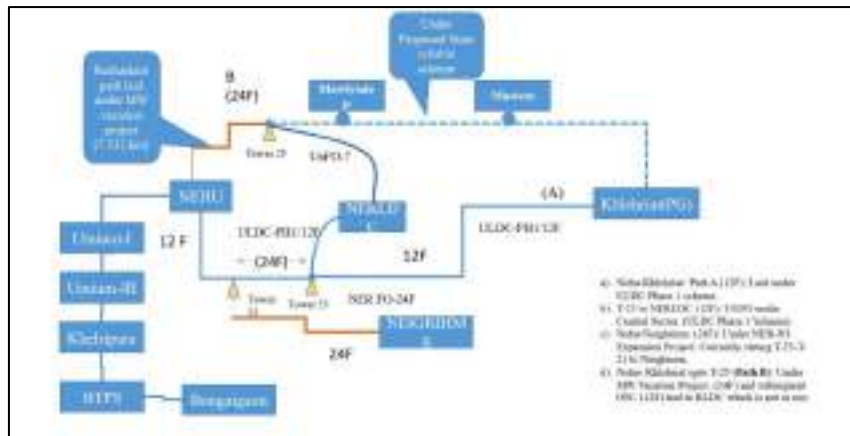

Connectivity diagram of NERLDC

Deliberations in 26th NETeST meeting: MePTCL informed the forum that they desire to BOO (Build – Own – Operate) the OPGW in their Transmission lines. POWERGRID – ULDC informed the forum that NEHU – Khlehiat link has been laid in ULDC Phase 1. They are also laying a 12F link from T23 of Nehu – Khlehiat to NERLDC. POWERGRID – ULDC also informed that under MW vacation project, a 7.532KM 24F NEHU – T25 link was laid; whereas T25- Mawlyndep – Mustem – Khlehiat link was to done under State reliable scheme. However, as MePTCL has desired to BOO these links, POWERGRID is ready to handover these link to MePTCL on a mutually agreeable date provided maintenance of these links are also undertaken by MePTCL. POWERGRID also informed that due to system constraint, if required, the 7.532KM NEHU – T25 link can be decapped subject to TCC/RPC approval. CTU also informed the forum that the ownership and maintenance accountability of these links has to be established before such proposed transfer. The forum noted as these are policy matters which warrants further detailed deliberation, the forum decided to conduct a separate meeting for the same.

Members may deliberate.

Deliberation:

It was suggested in the forum that 48 fibers may be laid and maintained by POWERGRID on Meghalaya owned lines i.e “NERLDC Shillong – NEHU”, “132 kV Kahilipara – Umiam Stg. III – Umiam Stg. I – NEHU” . Out of 48 fibers, 24 fibers will be for ISTS use and rest 24 fibers for state purpose.

This was agreed in the forum. However, Meghalaya stated that they will have to take consent from their management for the said proposal.

CTU also requested POWERGRID to provide OTDR report for the running link so that the proposal for replacement may be substantiated.

B.2: Status updation agenda

1) Providing redundant path to radial nodes in North Eastern Region

As per the CEA communication planning manual clause 4.1.2, the radial ISTS nodes are required to be connected on redundant paths. In this regard, CTUIL has prepared the list of nodes/stations/generating stations, which are on radial fibre connectivity or on single communication path (PLCC/Leased line etc) as under:

S. No.	Station Name	Paths
i)	Kameng(NEEPCO)	PLCC link
ii)	Ziro(PG)	Single fiber path

i) Kameng (400kV NEEPCO)

Fiber path connecting Kameng to Balipara is under implementation. Presently, Kameng is communicating with Balipara through PLCC.

For second path connectivity of Kameng, agenda was deliberated in 2nd meeting of NER ISTS communication system planning.

The agenda was further discussed in 23rd TCC and 23rd NERPC meeting held on 18th and 19th November 2022. After detailed deliberations, TCC forum recommended POWERGRID to install fiber for 132kV Balipara-Nechipu-Dokumpani-Dikshi- Khupi-Kameng (under implementation in comprehensive scheme by POWERGRID) at the earliest. The RPC approved the recommendation of TCC.



Connectivity of Kameng

Deliberations in 4th CPM: For the direct link between Kameng and Balipara, POWERGRID informed that OPGW stringing is completed and equipment installation and commissioning is pending due to unavailability of DCPS which needs to be provided. POWERGRID told that the link shall be commissioned by **15th August 23**.

Minutes of Special Review Meeting held on 7th March, 2024
links to NERLDC, Shillong via 400 kV Silchar- Byrnihat Line and 220 kV New Shillong S/s.

(b) 132 kV NEHU – Khliehriat CKT-II

NERLDC informed the forum that 12F OPGW between NEHU to Khliehriat was laid in ULDC Phase-1 and it has completed its useful life of 15 years. As such replacement of the same has become essential. After detailed deliberation, the forum agreed to the following:

1. **48F OPGW from NEHU to Khliehriat:** The Forum suggested that the OPGW should be upgraded to 48F by POWERGRID in consultation with CTU.
2. **From T-23 to NERLDC:** 12F Underground cable will be upgraded to 24F cable which is already part of the Reliable communication scheme.
3. **From T-23 to NEIGRIHMS:** 24F OPGW is already laid under the NER FO scheme which will be connected to NEHU and Khliehriat.
4. The proposed distribution of the fiber shall be as follows:

SN	From	To	Number of Fiber
1	NEHU	Khliehriat	24F
2	NEHU	NERLDC	12F
3	NERLDC	Khliehriat	12F
4	NEHU	NEIGRHIMS	12F
5	NEIGRHIMS	Khliehriat	12F

5. CEA has constituted a committee under the chairmanship of Member (Power System), CEA for formulating comprehensive guidelines for the usage and sharing of optical fibers (OPGW) for power system applications. NER will follow the guidelines approved by the committee.

The forum noted as above.

Action: POWERTEL, MePTCL, POWERGRID-ULDC, CTUIL, NERLDC & NERPC.

A.2 Replacement of FO link for “NERLDC Shillong – NEHU”, “132 kV Kahilipara – Sarusajai” and “132 kV Kahilipara – Umiam Stg. III – Umiam Stg. I – NEHU”.

Grid-India stated that in the 23rd TCC and NERPC meeting, TCC forum recommended for replacement of OPGW with 24 Fiber for NERLDC Shillong – NEHU”, “132 kV Kahilipara – Sarusajai” and “132 kV Kahilipara – Umiam Stg. III – Umiam Stg. I – NEHU” after RPC and NCT approval. This proposal for replacement shall be substantiated with test report of fiber healthiness. But test report is not available with

Meghalaya SLDC as the links have not been handed over to them by POWERGRID. POWERGRID stated that automatic handing over of the link ownership takes place after completion of fifteen years.

Further deliberations were held regarding ownership and maintenance of the said links. CTUIL stated that since these links are being used for ISTS data & voice communication and this communication shall be kept intact. In view of this CTU requested POWERGRID to clarify the entity who is maintaining the above said lines.

Deliberations in 4th CPM: POWERGRID told that this link contains critical ISTS data and this is the only path for NERLDC connectivity with only 12 Fibers. POWERGRID shared the connectivity diagram of NERLDC (as shown in figure below) and explained the criticality of these links. POWERGRID told that if Meghalaya is ready to maintain and takeover the link they have no issue in handing over these links.

However, GRID-INDIA informed that one of the above links i.e 132 kV Kahilipara – Sarusajai section belongs to Assam which is not vital for NERLDC connectivity and replacement of OPGW on this link shall be considered separately in consultation with Assam. Further, GRID-INDIA stated that 132kV NEHU-Umiam-I-Umiam -III is critical for Grid operation as most of the NERLDC data and AGC data is being routed through this path. In view of this, GRID-INDIA requested CTU for approval for laying of OPGW on these lines to be obtained from NCT. CTU suggested OPGW replacement on all these links may be carried out by single party considering reliability of backbone connectivity to NERLDC. CTU clarified that for approval of OPGW replacement on these lines under ISTS scheme from NCT, the replacement of OPGW shall be substantiated with test report of fiber healthiness which was asked for in the 23rd TCC and NERPC meeting also.

POWERGRID also intimated that Meghalaya is also implementing OPGW on Khleiriat-NEHU section which provides path redundancy for NERLDC. CTU suggested POWERGRID to check whether 48 Fibers can be laid on the “NERLDC Shillong – NEHU” and “132 kV Kahilipara – Umiam Stg. III – Umiam Stg. I – NEHU” paths so that fibers can be shared for ISTS and STU purposes. CTU requested POWERGRID to provide test-report of fiber healthiness of these links so that further review/approval in NETeST/TCC/NERPC & subsequently NCT may be taken up.

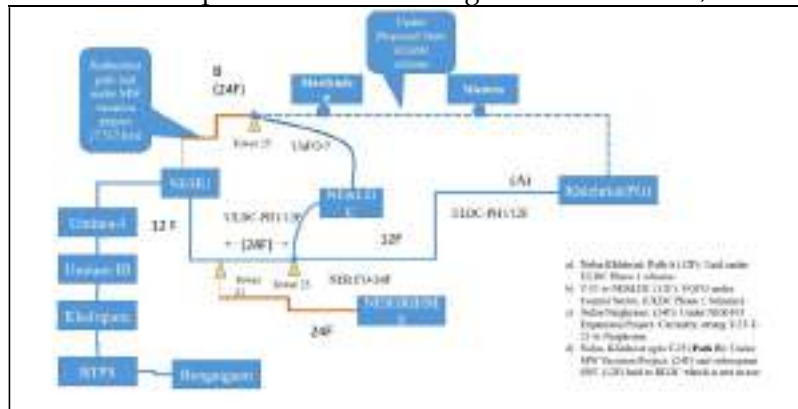

Connectivity diagram of NERLDC

Deliberations in 26th NETeST meeting: MePTCL informed the forum that they desire to BOO (Build – Own – Operate) the OPGW in their Transmission lines. POWERGRID – ULDC informed the forum that NEHU – Khlehriat link has been laid in ULDC Phase 1. They are also laying a 12F link from T23 of Nehu – Khlehriat to NERLDC. POWERGRID – ULDC also informed that under MW vacation project, a 7.532KM 24F NEHU – T25 link was laid; whereas T25- Mawlyndep – Mustem – Khlehriat link was to be done under State reliable scheme. However, as MePTCL has desired to BOO these links, POWERGRID is ready to handover these link to MePTCL on a mutually agreeable date provided maintenance of these links are also undertaken by MePTCL. POWERGRID also informed that due to system constraint, if required, the 7.532KM NEHU – T25 link can be decapped subject to TCC/RPC approval. CTU also informed the forum that the ownership and maintenance accountability of these links has to be established before such proposed transfer.

In 27th NETeST meeting, it was decided that separate meeting shall be conducted.

Deliberation of the forum:

- (a) **Replacement of FO link for “NERLDC Shillong – NEHU”** - discussed in Agenda A.1.
- (b) **Replacement of FO link for “132 kV Kahilipara – Sarusajai”** – The forum noted that as this AEGCL’s section is not vital for NERLDC connectivity so replacement and maintenance of OPGW on this section shall be considered by State/STU.
- (c) **Replacement of FO link for “132 kV Kahilipara – Umiam Stg. III – Umiam Stg. I – NEHU”** – CTUIL via email informed that as per the discussion held in 5th CPM meeting of CTUIL, it was suggested in the forum that 48 fibers may be laid and maintained by POWERGRID on Meghalaya owned lines “132 kV Kahilipara – Umiam Stg. III – Umiam Stg. I – NEHU”. Out of 48 fibers, 24 fibers

Minutes of Special Review Meeting held on 7th March, 2024
will be for ISTS use and the rest 24 fibers for state purpose. This was agreed in the forum. However, Meghalaya stated that they will have to take consent from their management for the said proposal.

Meghalaya (MePTCL) informed that their management has approved the laying and maintenance of 48 fibers by POWERGRID in “132 kV Kahilipara – Umiam Stg. III – Umiam Stg. I – NEHU” subject to the use of 24 fibers for ULDC/System requirement and balance for their own commercial purpose. However, POWERGRID opined that the usage and sharing of the fibers is to be done as per CEA/CERC guidelines/regulations.

Additionally, MePTCL has made a request to connect the 132 kV Kahilipara – Umiam Stage III line at 132 kV Umtru for improved connectivity. The forum agreed to the same and endorsed the establishment of the link as 132 kV Kahilipara – Umtru - Umiam Stg. III – Umiam Stg. I – NEHU. Further discussions regarding the distribution of OPGW between ULDC-POWERGRID and MePTCL to take place in subsequent meetings.

AEGCL highlighted the critical nature of the 132 kV Kahilipara – Umtru OPGW link for Assam, NERLDC, and Meghalaya. AEGCL requested that the OPGW over the 132 kV Sarusajai – Umtru line to be considered as a redundant path. The forum has acknowledged the same and decided to deliberate on it in forthcoming meetings.

The forum noted as above.

Action: MePTCL, AEGCL, POWERGRID-ULDC, CTUIL, NERLDC & NERPC.

Any other item:

A.3 Connectivity of NERLDC Guwahati with Sarusajai and Umiam bypassing Kahilipara for its redundancy.

During a meeting held on August 8th, 2022, involving Communication-AEGCL, SLDC Assam, NERLDC Grid-India, and ULDC-POWERGRID, several decisions were made. It was agreed that POWERGRID would lay two 24-core fiber optic cables from NERLDC Guwahati to Gantary of Kahilipara. At Gantary, a Joint Box would be installed, facilitating the connection of one cable from NERLDC to the Sarusajai direction and the other cable to the Umtru direction.

MoM for virtual meeting held on 02.11.2023 for Dual reporting of RTU, PMU, VOIP, AGC etc. applications on 2+2 channel to main RLDC and Backup RLDC for North Eastern Region

Meeting started with opening remarks from Sr. DGM (CTUIL). He welcomed the participants in the meeting and made them aware about the growing communication requirements for ISTS as renewable energy is being injected into the grid at a very fast pace.

List of participants is attached at **Annexure-I**.

The agenda was discussed in 4th CPM dated 28.07.2023 and in the 26th NETeST meeting for North Eastern region specifically. POWERGRID has provided the requirement of FOTE, Ethernet cards, SAS, cards in SAS as per enclosed list in **Annexure-II**.

Deliberations:

POWERGRID provided following inputs:

1)POWERGRID provided the data for requirement of ports in SAS/RTU as per enclosed **Annexure-III**. However, POWERGRID shall clarify whether new SAS or new ethernet card is required in existing SAS after discussion with their AM department. POWERGRID to provide the cost estimate for required ethernet card/ SAS also.

2)Cost of one ethernet card for FOTE was stated by POWERGRID as 1.25 lacs approx.

3)CTU stated that as per the data provided by POWERGRID, one no. of SDH each at Ziro, Loktak and NTPC BgTPP is required. However, additional SDH for Loktak and NTPC BgTPP have already been considered in 'Additional FOTE for AGC scheme' and the requirement for dual redundancy at these two locations shall be met with these FOTES at these locations. CTU further stated that for requirement of additional ethernet card at NTPC BgTPP, POWERGRID may include this requirement in the additional SDH requirement at NTPC BgTPP in the 'Additional FOTE for AGC scheme'. POWERGRID agreed with the same.

4)Requirement of one no. of SDH with minimum 8 no. of ethernet ports was agreed in the meeting for Ziro S/s.

Meeting ended with a vote of thanks from CTUIL.

Annexure-I

The list of participants is listed below:

Sr. No.	Name	Company Name	Designation
1	Shri H.S Kaushal	CTUIL	Sr.GM
2	Shri S.K Gupta	CTUIL	Sr.DGM
3	Shri Kaushal Suman	CTUIL	Mgr
4	Shri Vishal Badlas	POWERGRID	Mgr

Availability of additional requirement of RTU/SAS ethernet port at substation for dual redundancy of channels at Main and Back up RLDC				
Region	Name of Substation	Data reporting RLDC through RTU/SAS GW	RTU/SAS	
			Are 5 no. of ethernet port available in existing RTU/SAS?(YES/NO)	If no, please mention requirement of RTU/SAS/Ethernet card.
NER	Kumarghat S/S	SAS GW	No	01 no. of spare port required in 2 gateways each as from each gateway 01 port is already reporting to RLDC. Data reporting to RLDC, RTAMC, BNTAMC, NTAMC from each gateway.
NER	Jiribam	SAS GW	No	01 no. of spare port required in 2 gateways each as from each gateway 01 port is already reporting to RLDC. Data reporting to RLDC, RTAMC, BNTAMC, NTAMC from each gateway.
NER	Haflong	SAS GW	No	01 no. of spare port required in 2 gateways each as from each gateway 01 port is already reporting to RLDC. Data reporting to RLDC, RTAMC, BNTAMC, NTAMC from each gateway.
NER	Dimapur	SAS GW	No	01 no. of spare port required in 2 gateways each as from each gateway 01 port is already reporting to RLDC. Data reporting to RLDC, RTAMC, BNTAMC, NTAMC from each gateway.
NER	Aizawl	SAS GW	No	01 no. of spare port required in 2 gateways each as from each gateway 01 port is already reporting to RLDC. Data reporting to RLDC, RTAMC, BNTAMC, NTAMC from each gateway.
NER	Roing	SAS GW	No	01 no. of spare port required in 2 gateways each as from each gateway 01 port is already reporting to RLDC. Data reporting to RLDC, RTAMC, BNTAMC, NTAMC from each gateway.
NER	Tezu	SAS GW	No	01 no. of spare port required in 2 gateways each as from each gateway 01 port is already reporting to RLDC. Data reporting to RLDC, RTAMC, BNTAMC, NTAMC from each gateway.
NER	Namsai	SAS GW	No	01 no. of spare port required in 2 gateways each as from each gateway 01 port is already reporting to RLDC. Data reporting to RLDC, RTAMC, BNTAMC, NTAMC from each gateway.
NER	Mokokchung	SAS GW	No	Presently station is reporting on IEC-101 from each gateway to RLDC. If reporting is to be made on IEC-104 then, there shall be requirement of 02 Nos Port in each gateway. Details of ports used in each gateway : 104 ports - RTAMC, NTAMC, BNTAMC, spare, 101 port - RLDC
NER	Melriat	SAS GW	No	01 no. of spare port required in 2 gateways each as from each gateway 01 port is already reporting to RLDC
NER	Balipara	RTU	No	Data is reporting to RLDC via 01 no. port (101 protocol) of Main & Standby Gateway each. Details of ports used in each gateway : 104 ports - RTAMC, NTAMC, BNTAMC, spare, 101 port - RLDC Being conventional station, data is also reporting through RTU via 1 port. Another 01 no port shall be required for Back up RLDC.
NER	Misa	RTU	No	Data is reporting to RLDC via 01 no. port (101 protocol) of Main & Standby Gateway each. Details of ports used in each gateway : 104 ports - RTAMC, NTAMC, BNTAMC, spare, 101 port - RLDC Being conventional station, data is also reporting through RTU via 1 port. Another 01 no port shall be required for Back up RLDC.
NER	Bongaigaon	RTU	No	Data is reporting to RLDC via 01 no. port (101 protocol) of Main & Standby Gateway each. Details of ports used in each gateway : 104 ports - RTAMC, NTAMC, BNTAMC, spare, 101 port - RLDC Being conventional station, data is also reporting through RTU via 1 port. Another 01 no port shall be required for Back up RLDC.
NER	BNC	SAS GW	No	01 no. of spare port required in 2 gateways each as from each gateway 01 port is already reporting to RLDC. For BNTAMC 01 no. of spare port required in 2 gateways each as from each gateway 01 port is already reporting to NTAMC.
NER	Badarpur	RTU	No	Data is reporting to RLDC via 01 no. port (101 protocol) of Main & Standby Gateway each. Details of ports used in each gateway : 104 ports - RTAMC, NTAMC, BNTAMC, spare, 101 port - RLDC Being conventional station, data is also reporting through RTU via 1 port. Another 01 no port shall be required for Back up RLDC.
NER	Khelrihat	RTU	No	Being conventional station, data is reporting through RTU via 1 port. Another 01 no port shall be required for Back up RLDC
NER	Silchar	SAS GW	No	Presently station is reporting on IEC-101 from each gateway to RLDC. If reporting is to be made on IEC-104 then, there shall be requirement of 02 Nos Port in each gateway. Details of ports used in each gateway : 104 ports - RTAMC, NTAMC, BNTAMC, spare, 101 port - RLDC
NER	Mariani	SAS GW	No	01 no. of spare port required in 2 gateways each as from each gateway 01 port is already reporting to RLDC. Details of ports used in each gateway : 104 ports - RTAMC, NTAMC, BNTAMC, spare, 101 port - RLDC
NER	Nirjuli	SAS GW	Yes	
NER	Ziro	RTU	No	Being conventional station, data is reporting through RTU via 1 port. Another 01 no port shall be required for Back up RLDC
NER	Salakati	SAS GW	Yes	Existing 02 nos. of D400 gateway has 01 spare port each. From both D400 gateways, 01 port is reporting to RLDC.
NER	Imphal	SAS GW	No	01 no. of spare port required in 2 gateways each as from each gateway 01 port is already reporting to RLDC. Details of ports used in each gateway : 104 ports - RTAMC, NTAMC, BNTAMC, spare, 101 port - RLDC .

* Additionally required ethernet port over and above existing capacity.

Note - For additional port reporting to Back up RLDC, necessary configuration in SAS shall be required

	YES	NO
SAS	2	14
RTU	0	6

Availability details of RTU/SAS ethernet port at various POWERGRID stations for data reporting to Main and Back up RLDC through redundant channels

Sl.No	Region	Total Stations	No of stations				Remarks
			SAS(Are 5 no. of ethernet ports available)		RTU(Are 5 no. of ethernet ports available)		
			Yes(No's)	No(No's)	Yes(No's)	No(No's)	
1	WR1	26	15	9	2	0	
2	WR2	32	9	18	4	1	
3	SR1	21	0	13	0	8	
4	SR2	38	0	25	0	13	
5	ER1	17	11	1	0	5	Upgradation WIP SAS_5, RTU_5
6	ER2	14	4	3	1	6	Upgradation WIP SAS_5, RTU_6
7	NR1	38	8	22	4	4	
8	NR2	25	1	18	5	1	
9	NR3	27	5	15	5	2	
10	NER	22	2	14	0	6	
11	ODISHA	10	5	0	0	5	Upgradation WIP SA_1, RTU_5
Total		270	60	138	21	51	
Final qty (Stations are Excluded which are under upgradation)				138		35	
						Rate per station(Cr.)	Amount in Crores
Total SAS based stations				138		1.5	207.00
Total RTU based stations					35	0.3	10.50
Grand Total							217.50



ANNEXURE II

Site Name	Total Licence (IP Phone)	IP Phone-configured in System	No of used IP Phone	Total Licence (SIP Phone)	SIP Phone-configured in system	No of used SIP Phone	Total Licence (2 Wire/Analog phone)	No of used Analog Phone	Analog Phone configured in system
Imphal	142	20	5	40	0	0	84	information to be provided by respective STU	96
SLDC,Nehu	142	25	20	40	5	5	84		96
Guwahati	142	56	25	40	0	0	148		96
Aizwal	142	11	4	40	0	0	84		34
Diamapur	142	26	4	40	0	0	84		70
Agartala	142	44	8	40	0	0	116		96
Itanagar	142	25	4	40	0	0	84		70
	994	207	70	280	5	5	684		0

Meeting among Assam-SLDC, AEGCL, NERLDC and POWERGRID-NERTS for site-survey related to planning of Optical-fiber connectivity for NERLDC/Assam-SLDC held at SLDC conference room on 08th August 2022, 1130 Hrs.

A meeting was held among representatives from Assam-SLDC, NERLDC, AEGCL and POWERGRID-NERTS related to planning of fiber-optic connectivity to ensure reliability and redundancy of communication links at NERLDC (new premises) and Assam-SLDC at Kahilipara, Guwahati. The list of participants is listed below.

Arup Kalita (Dy. GM, AEGCL)	S.P. Barnwal (Sr. GM, NERLDC)
Ashutosh Bhattacharjee (Dy. GM, Assam-SLDC)	Akhil Singhal (Ch. Manager, NERLDC)
Pranab Saha (Asst. GM, Assam-SLDC)	Sakal Deep (Asst. Manager, NERLDC)
Ashwini Gogoi (Asst. GM-Kahilipara, AEGCL)	Ashutosh Kumar (Asst. Manager, NERLDC)
Arup Sarma (Asst. GM-Communication, AEGCL)	Kamlesh Baishya (Asst. Manager, POWERGRID)
Rupjyoti Das (Dy. Manager, Assam-SLDC)	P. Johny Singh (Jr. Engineer, POWERGRID)

The meeting started with an outset discussion that planning for adequate reliability and redundancy is of utmost importance for the real-time data telemetry purposes of NERLDC/Assam-SLDC considering its mission critical operations of national importance in power sector. The summary of discussion is mentioned below.

1.0 Directions of communication in optical network

It was deliberated that two directions are necessary for optical fiber communication purposes so as to ensure that any disruption in one direction does not hamper the data-availability at NERLDC/Assam-SLDC. AEGCL & NERTS suggested that two (02) joint boxes are available at Kahilipara sub-station through which one route towards Umiam and other route towards Sarusajai can serve the purpose with one (01) fiber-pair in each route.

Moreover, the SLDC is connected to Rangia and BTPS stations on which bandwidth can be used to provide 10Mbps or more (as required) dedicated links over Ethernet which can be used under any emergency measure by enabling it through associated NMS systems.

2.0 New optical-fibers required for strengthening connectivity of NERLDC, Guwahati and Assam-SLDC

It was discussed that new fibers needs to be laid at few locations as listed in table below.

Sl. No.	Description	Existing/New	Estimated length/ Qty.	No. of cores required	Remarks
1	NERLDC to Assam SLDC (Back-side of Assam-SLDC to back-side of NERLDC)	New fiber to be laid underground	To be depicted as per site-survey	24	NERLDC: Fibcom (existing) & Tejas (SDH under procurement through reliable scheme)

Sakal Deep
Arup Kalita

P. Johny Singh
(P. J. SINGH)

Page 1 of 3
Kamlesh Baishya
(KAMLESH BAISHYA)

Sl. No.	Description	Existing/New	Estimated length/ Qty.	No. of cores required	Remarks
					Assam-SLDC: Keymile, ECI & Fibcom
2	Kahilipara (Gantry) to NERLDC (Separate route from Gantry of Kahilipara to NERLDC Communication Room)	New fiber to be laid underground	To be depicted as per site-survey	24 x 2	NERLDC: FODB Kahilipara: Joint Boxes (One towards to Sarusajai & One towards to Umiam)
3	Kahilipara to Sarusajai (Existing fiber installed in 2003)	12-core OPGW to be upgraded with 24-core OPGW	4 kms. (approx.) which may be included under Qty. variation in reliable communication scheme of POWERGRID after taking approval in upcoming TCC/NERPC Board meeting.	24	Proposal for replacement of OPGW will be placed by AEGCL/NERLDC in TCC/NERPC Board meeting.
4	Kahilipara to Umiam-III to Umiam I-NEHU (Existing fiber installed in 2003)	12-core OPGW to be upgraded with 24-core OPGW	May be included under Qty. variation in reliable communication scheme of POWERGRID after taking approval in upcoming TCC/NERPC Board meeting.	24	Proposal for replacement of OPGW will be placed by PGCIL/NERLDC in TCC/NERPC Board meeting.
5	NERLDC to Rangia (Via Assam-SLDC)	Existing fibers; configuration to be done in NMS.	10Mbps or more dedicated channel to be configured using state network. Inter-patching between FOTEs will be done at	--	NERLDC: Fibcom (existing) & Tejas (SDH under procurement through reliable communication scheme) Assam-SLDC:

Shankar (Sakal Dept) [Signature] [Signature]

[Signature] (P. J. SINGH)

[Signature] (KAMLESH BATHAM)

Sl. No.	Description	Existing/New	Estimated length/ Qty.	No. of cores required	Remarks
			SLDC Assam and Rangia		Keymile, ECI & Fibcom Rangia: Keymile
6	NERLDC to BTPS (Via Assam-SLDC)	Existing fibers; configuration to be done in NMS.	10Mbps dedicated channel to be configured using state network. Inter-patching between FOTEs will be done at SLDC Assam and Rangia		NERLDC: Fibcom (existing) & Tejas (SDH under procurement through reliable communication scheme) Assam-SLDC: Keymile, ECI & Fibcom BTPS: Keymile
7	Additional card procurement and associated commissioning	New cards may need to be procured for various locations	To be listed after site-survey at all associated locations.	--	May be required in Assam-SLDC Rangia & BTPS which needs to be checked.



3.0 Communication to POWERGRID-NERTS related to the OPGW communication and associated end-equipment works

POWERGRID-NERTS requested that a consent from Assam-SLDC/AEGCL may be required for carrying out the necessary OPGW/ Underground Fiber-Optic laying works as per the final route depicted during joint site-survey (refer **Annexure-1** for route) carried out with AEGCL in presence of Assam-SLDC and NERLDC representatives.

Moreover, the necessary written communication for including Kahilipara-Sarusajai OPGW replacement (12-fiber to 24-fiber) under reliable communication scheme may be given to POWERGRID-NERTS and the same may also be taken up as an agenda item for approval in next TCC/NERPC Board meeting by AEGCL/NERLDC.

Meeting ended with noting of the above.

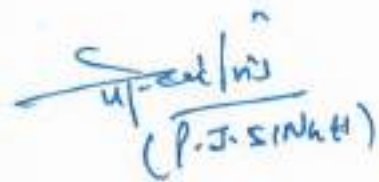
 Sakal Das
 Lakshmi SenGual
 S.P. BARNWAL

 P.J. SINGH
 KARISHMA RASHMI

ANNEXURE - 1

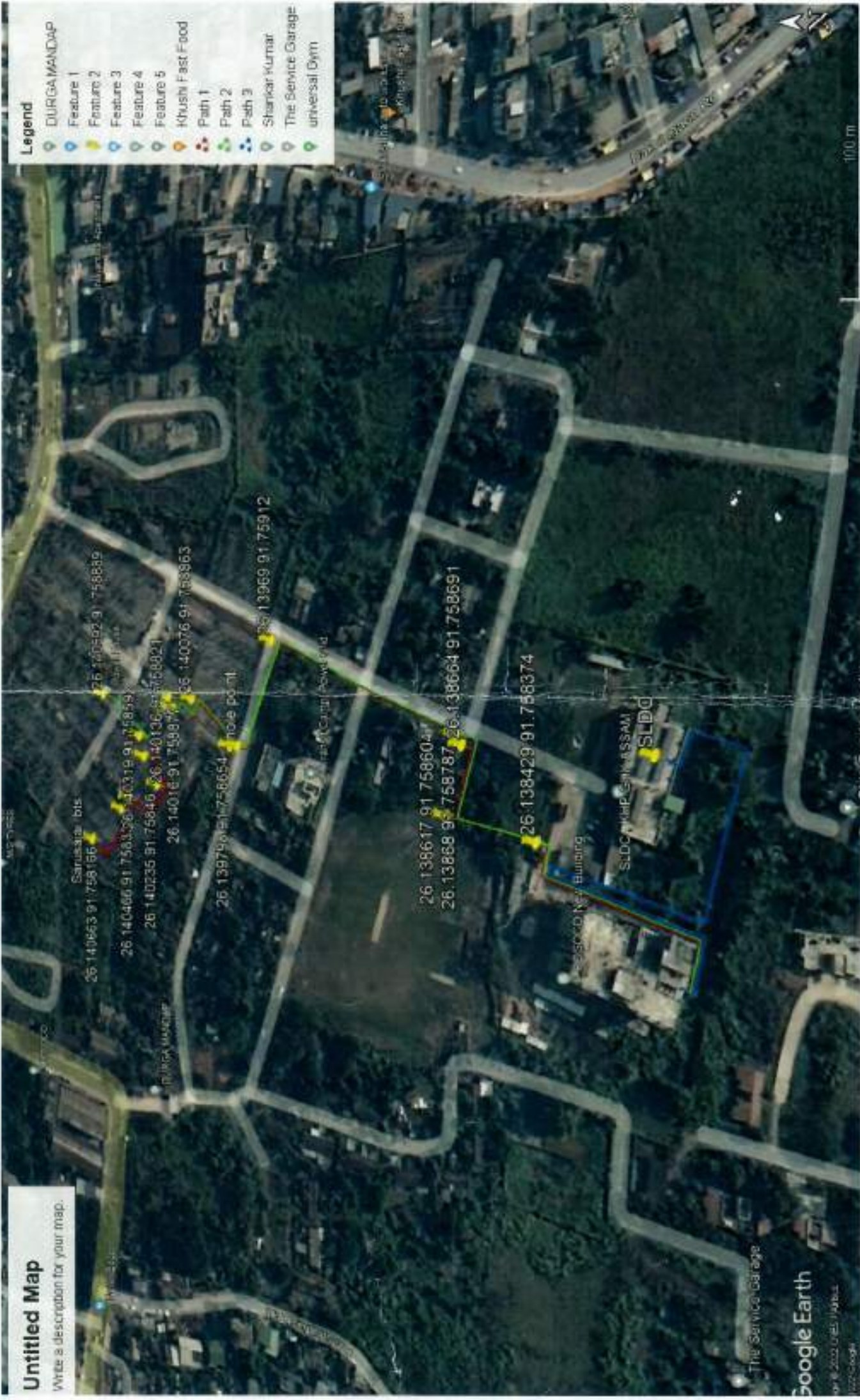

Handwritten signature: श्री अशोक (P. S. SINGH)

Handwritten signature: Shankar Kumar (Central Dept) d.d.y.

RE: Intimation of timeline for revival of PLHPS-Itanagar and PLHPS-Pare HPS Ckt-II: Status of OPGW link between PHEP & RHEP regarding.

Narottam Chakraborty <narottam.chakraborty@sterlite.com>

Sun 28-04-2024 21:37

To: Vikash Shankar Singh <vikashiitk308@gmail.com>; Sakal Deep (सकल दीप) <skldeep@grid-india.in>;

Cc: Bhuwanesh Joshi <bhuwanesh.joshi@sterlite.com>; Raushan Kumar <raushan.kumar@sterlite.com>; Kamlesh Baishya (कमलेश Baishya) <kamlesh156@powergrid.in>; nerpc@ymail.com <nerpc@ymail.com>; se.sopsc <se.sopsc@gmail.com>; msdutt@powergrid.in <msdutt@powergrid.in>; Amaresh Mallick (अमरेश मल्लिक) <amareshmallick@grid-india.in>; sundarmoni@neepco.co.in <sundarmoni@neepco.co.in>; santanu@neepco.co.in <santanu@neepco.co.in>; Joy Pal Roy, Manager E. M. ,KHEP NEEPCO,PAID <joypalroy@neepco.co.in>;

1 attachments (179 KB)

OTDR.pdf;

****Warning****

This email has not originated from Grid-India. Do not click on attachment or links unless sender is reliable. Malware/ Viruses can be easily transmitted via email.

Dear Sir

Reference to the trailing mail this is to inform you that as per approved scheme and attached MoM of meeting dated 10.07.2023 we have completed our responsibilities in all respect before commissioning of the North Lakhimpur-Nirjuli-Pare transmission lines on 31.07.23 and 01.08.23 with kind support of all.

Before receipt of this mail reference to the con calls already held with NEEPCO, NERLDC & ULDC we had arranged OPGW splicer and our team checked the continuity of the fibres on 26.04.24 between Pare HEP-Ranganadi HEP. Continuity of all the fibres were found to be available and 6 Nos. were already in use.

On discussion with Mr. Kamallesh Baishya it was confirmed fibre No. 3&4 are only used by ULDC and rest 1,2,11&12 may be used by PGCI (Communication).

We have also ensured connectivity of 2 fibres (7&8) for Diff. Protection of NEEPCO (PHEP-RHEP). The Photo of FODB is attached showing used and unused fibres for reference.



[@skldeep@grid-india.in](mailto:skldeep@grid-india.in) As discussed please confirm the purpose of using fibre Nos. 1,2,11&12 for record as MoM permits use of 4 No. fibres for Power System Purpose, 4 Nos. by NEEPCO & 4 Nos. by MUMML.

Thanking you all for continued support.

--

Regards

Narottam Chakraborty

AVP-Projects, Sterlite Power.

From: Vikash Shankar Singh <vikashiitk308@gmail.com> Dear Sir

Reference to your mail and mail of Mr. Kamlesh Baishya in trailing this is to inform you that as per approved scheme and attached MoM of meeting dated 10.07.2023 we have completed our responsibilities in all respect before commissioning of North Lakhimpur-Nirjuli-Pare transmission lines on 31.07.23 and 01.08.23. The reports had also been submitted to the NERLDC before obtaining FCT of the above elements under MUMML.

Before receipt of this mail reference to the con calls already held with NEEPCO, NERLDC & ULDC we had arranged OPGW splicer and our team checked the continuity of the fibres between Pare HEP-Ranganadi HEP. It is found continuity of the fibres were available and 6 Nos. were already in use. On discussion Mr. Kamallesh Baishya confirmed fibre No. 3&4 are only used by ULDC and rest may be used by PGCI (Communication).

We have also ensured connectivity of 2 fibres for Diff. Protection of NEEPCO. The Photo of FODB is attached showing fibres used and free.

Sent: Friday, April 26, 2024 11:19 AM

To: Narottam Chakraborty <narottam.chakraborty@sterlite.com>

Subject: Fwd: Intimation of timeline for revival of PLHPS-Itanagar and PLHPS-Pare HPS Ckt-II

[EXTERNAL EMAIL] Do not click links or attachments unless you recognize the sender and know the content is safe.

Sir,
W.r.t. the trailing mail, Kindly take necessary action to restore OPGW link between Rangandi and Pare HEP
Regards,
Vikash Shankar, IES(CPES)
AEE/AD-I, NERPC
MoP, Gol

----- Forwarded message -----

From: **Kamlesh Baishya {कमलेश Baishya}** <kamlesh156@powergrid.in>

Date: Thu, Apr 25, 2024 at 6:57 PM

Subject: Re: Intimation of timeline for revival of PLHPS-Itanagar and PLHPS-Pare HPS Ckt-II

To: Vikash Shankar Singh <vikashiitk308@gmail.com>

Cc: neepco edonm <neepco.edonm@gmail.com>, Joy Pal Roy, Manager E M ,KHEP NEEPCO,PAID <joypalroy@neepco.co.in>, Head of Plant Pare HPS <hoppare@neepco.co.in>, saniang@rediffmail.com <saniang@rediffmail.com>, ChaitanyaBh Gorja <gcbharath@neepco.co.in>, Santanu deb <Santanu@neepco.co.in>, Bhaskar Mazumder <bhaskarm@neepco.co.in>, aiegssd@gmail.com <aiegssd@gmail.com>, apslcd sd <apslcd.sd@gmail.com>, eesldcitaap@gmail.com <eesldcitaap@gmail.com>, mviswanadh@grid-india.in <mviswanadh@grid-india.in>, pranjalborkataki@grid-india.in <pranjalborkataki@grid-india.in>, vidyutarunachal@gmail.com <vidyutarunachal@gmail.com>, se transmissioncircle <se_transmissioncircle@rediffmail.com>, bimal swargiary <bimal.swargiary@grid-india.in>, se sopsc <se.sopsc@gmail.com>, nerpc@ymail.com <nerpc@ymail.com>, amareshmallick@grid-india.in <amareshmallick@grid-india.in>, biswajit@grid-india.in <biswajit@grid-india.in>, skldeep@grid-india.in <skldeep@grid-india.in>, hop plphs <hop.plphs@neepco.co.in>, exentdii@gmail.com <exentdii@gmail.com>, hodem plphs <hodem.plphs@neepco.co.in>, hop plphs <hop.plphs@neepco.co.in>, Ankit Vaish {अंकित वैश्य} <ankit_vaish@powergrid.in>, Haribabu Rudraraju {रुद्र राजू हरिबाबू} <rudraraju@powergrid.in>, Madhusudan Dutt {एम. दत्त} <msdutt@powergrid.in>, Patham Sridhar {पथम श्रीधर} <psridhar@powergrid.in>, Manash Jyoti Baishya {मानश ज्योति बैश्य} <mjbaishya@powergrid.in>, ftcnerldc@grid-india.in <ftcnerldc@grid-india.in>, Sundar Moni Mohan <sundarmoni@neepco.co.in>

Dear Sir,

As per meeting held on 10.07.2023 between NERPC, POWERGRID, NERLDC, NEEPCO, MUML (MOM attached), regarding reconfiguration of OPGW due to commissioning of Pare-N.Lakhimpur-Nirjuli line, the existing OPGW configuration was modified and the modifications were carried out by MUML as follows:

- 1.
2. 1. 24 Fibre between North Lakhimpur and Pare.
- 3.
4. 2.24 Fibre between North Lakhimpur and Nirjuli.
- 5.
6. 3.12 Fibre between Nirjuli and Pare.
- 7.
8. 4.12 Fibre between Pare and Ranganadi HEP.
- 9.

10. 5. 12 Fibre Nirjuli and Ranganadi HEP. (Schematic diagram attached in MOM).

The original 24F was dismantled and replaced with new fibre by MUML and Pare Ranganadi was connected over 12F (Refer Point 4a. of MOM which states "Removal of existing 24 Fibre OPGW of ULDC from LILO point (Ext. Tower. No. 09) to Pare" i.e., under MUML jurisdiction. As such, OTDR report received from Pare direction (attached) shows fibre issue at 327 m from Pare FODP) and OTDR report from Ranganadi direction shows link length of 9.81 km. From above, it is seen that the fibre break falls under MUML jurisdiction and thus matter may be taken up with MUML by concerned for further rectification.

Regards
Kamlesh Baishya
Asst.Manager
ULDC

From: Vikash Shankar Singh <vikashiitk308@gmail.com>

Sent: Wednesday, April 24, 2024 8:06 PM

To: ftcnerldc@grid-india.in <ftcnerldc@grid-india.in>; Sundar Moni Mohan <sundarmoni@neepco.co.in>

Cc: neepco edonm <neepco.edonm@gmail.com>; Joy Pal Roy, Manager E M ,KHEP NEEPCO,PAID <joypalroy@neepco.co.in>; Head of Plant Pare HPS <hoppare@neepco.co.in>; saniang@rediffmail.com <saniang@rediffmail.com>; ChaitanyaBh Gorja <gcbharath@neepco.co.in>; Santanu deb <Santanu@neepco.co.in>; Bhaskar Mazumder <bhaskarm@neepco.co.in>; aiegssd@gmail.com <aiegssd@gmail.com>; apslcd sd <apslcd.sd@gmail.com>; eesldcitaap@gmail.com <eesldcitaap@gmail.com>; mviswanadh@grid-india.in <mviswanadh@grid-india.in>; pranjalborkataki@grid-india.in <pranjalborkataki@grid-india.in>; vidyutarunachal@gmail.com <vidyutarunachal@gmail.com>; se transmissioncircle <se_transmissioncircle@rediffmail.com>; bimal swargiary <bimal.swargiary@grid-india.in>; se sopsc <se.sopsc@gmail.com>; nerpc@ymail.com <nerpc@ymail.com>; amareshmallick@grid-india.in <amareshmallick@grid-india.in>; biswajit@grid-india.in <biswajit@grid-india.in>; skldeep@grid-india.in <skldeep@grid-india.in>; hop plphs <hop.plphs@neepco.co.in>; exentdii@gmail.com <exentdii@gmail.com>; hodem plphs <hodem.plphs@neepco.co.in>; hop plphs <hop.plphs@neepco.co.in>; Ankit Vaish {अंकित वैश्य} <ankit_vaish@powergrid.in>; Haribabu Rudraraju {रुद्र राजू हरिबाबू} <rudraraju@powergrid.in>; Kamlesh Baishya {कमलेश Baishya} <kamlesh156@powergrid.in>

Subject: Re: Intimation of timeline for revival of PLHPS-Itanagar and PLHPS-Pare HPS Ckt-II

Sir/Madam,

Minutes of the Meeting of Discussion on Detailed Project Report (DPR) of SCADA/EMS Upgradation Project – ULDC Phase III in North Eastern Region held via online mode on 3rd May 2024.

Date: 3rd May 2024

Venue: Online Mode

Time: 11:00 Hrs

CGM (SL), NERLDC welcomed all the members for the meeting. He pressed on the matter that AMC for SCADA/EMS ULDC Phase II for few of the states of NER have expired, which is a matter of concern and those NER SLDCs should give due attention to this matter and award the extended AMC at the earliest to get proper support from M/S GE. He further added, Budgetary offers have been received from M/S L&T and M/S GE for the Upgradation of SCADA/EMS ULDC Phase III. To sensitize the states about signing of DPR, this meeting has been organized. It was also informed that, the Draft DPRs (Part A) for each State has already been circulated to each state and they are required to work on getting Management approvals of the same and submit it to PSDF Secretariat through NERPC with a copy to NERLDC at the earliest.

Member Secretary, NERPC appreciated NERLDC for the efforts that they have made for the SCADA/EMS project till now. He again reiterated that PSDF grant has already been approved for this upgradation project. DRPs have not been signed by any of the states yet. Same should be done at the earliest. He also emphasized that, in the upgraded SCADA Systems, Cyber Security aspects will also be met as stipulated in CEA/CERC guidelines.

ED, NERLDC emphasized regarding preparation and signing of DPRs and submission to PSDF Secretariat through NERPC at the earliest.

Afterwards there was a small round of introduction of all the participants present during the meeting.

1.0 General Discussion

Manager, NERLDC presented the highlights of the present status of the ULDC-Phase III Project for NER States.

During the presentation, NERLDC highlighted that written confirmation regarding finalization of the Backup SLDC of Arunachal Pradesh is yet to be received. In reply, SLDC Arunachal Pradesh confirmed that Pasighat has been already fixed. A written confirmation will be sent to NERLDC soon.

2.0 Discussion Regarding AMC Extension for ULDC Phase -II

Extended AMC of Assam will expire on 11-11-2024. Member Secretary, NERPC requested SLDC Assam to talk with M/S GE for further extension of the AMC for 1-2 years. Assam SLDC stated that, they shall request M/s GE to extend support for another 2 years.

It has been highlighted that M/S GE has been providing support without AMC to Manipur, Mizoram and Tripura.

On enquiry, SLDC Tripura mentioned that MD, TPTL has already approved the extension of AMC on 03-05-2024, and LOA will be issued at the earliest. They further added later on, due to General Elections Code of Conduct has been imposed, so they are unable to award the amended LOA. It will be done once the Code of Conduct is lifted. This was already communicated to M/s GE by SLDC Tripura.

SLDC Manipur has also confirmed that internal approval (from Board) has been taken by them and in 2-3 weeks, LOA will be issued.

SLDC Mizoram confirmed that internal approval has been obtained and that LOA issuance will be done within a week's time.

Manager, NERLDC informed that, a paragraph may be inserted in the draft DPRs which gives special emphasis on the difficulties faced due to the hilly nature and remoteness of the terrain in NER. The paragraph is given below and may be inserted in Format A4, section 2.1 Cost Estimate:

"Additionally, the hilly terrain of the state presents unique challenges that may contribute to higher costs. Transportation of equipment and materials across difficult, hilly regions increases logistical complexities and expenses. These factors, combined with the need to maintain reliable connectivity and system performance across the rugged landscape, result in elevated expenses compared to projects in less challenging environments.

As a result, the overall cost estimate for the SCADA/EMS upgradation, including the Comprehensive AMC, is expected to be higher to account for these logistical and infrastructural hurdles."

3.0 Preparation of Part A (Upgradation of SCADA/EMS) and Part B (Construction of Backup SLDC) of DPRs by NER States.

3.1 Assam:

SLDC Assam has confirmed that Part B of DPR has been prepared by them and it has been routed for internal scrutiny. Same will be submitted shortly. CGM (SL), NERLDC requested SLDC Assam to share the Draft Part B of DPR with NERLDC so that common

format can be prepared and shared with other NER States. SLDC Assam has agreed to share the same at the earliest. SLDC Assam has communicated that they have received budgetary estimates for Part B of DPR amounting to Rs. 24.0 crores.

Regarding the Part A, SDLC Assam has mailed some queries to NERLDC. CGM (SL), NERLDC communicated that the reply on their queries will be provided after discussion with CC-Engineering, GRID-INDIA.

3.2 Manipur:

SLDC Manipur enquired about incorporation of Email Servers in the BoQ. CGM (SL), NERLDC conveyed that since email servers are a part of IT infrastructure; so the same cannot be clubbed with OT.

SLDC Manipur also enquired whether AMC charges are included within the scope of this project/PSDF Fund, to which CGM (SL), NERLDC confirmed that 7 years (1 year DLP + 6 years AMC) support by vendor is included in the scope of this project.

CGM (SL), NERLDC mentioned that, manpower shall be required for manning the Back-up SLDC and Main SLDC, States shall be liable for ensuring the same.

Regarding the Part B of DPR, SLDC Manipur highlighted that the Civil Division is preparing the Part B of DPR and the same will be done within 2 weeks.

3.3 Mizoram

SLDC Mizoram highlighted that Part B of DPR has already been submitted to NERPC. However, NERLDC informed that, the same was also checked by them and it was not found to be in proper format of PSDF. SLDC Mizoram told that they will modify the same and resubmit after receiving the draft DPR format of Part B from NERLDC.

3.4 Arunachal Pradesh

SLDC Arunachal Pradesh mentioned that Part A will take a few more days for completion.

Regarding Part B, SLDC Arunachal Pradesh mentioned that Draft DPR has been prepared and the same will be shared with NERLDC.

3.5 Nagaland

SLDC Nagaland had a query regarding Part A- BoQ, where SMS services have been omitted. NERLDC clarified that the same has already been deliberated on 22nd Nov 2023

meeting at NERLDC, Guwahati and only the integration part of SMS and Internet had been kept in the scope of the vendor and SMS Services needs to be taken by the respective user/owner. As per statutory guidelines by TRAI, SMS and Internet to be in the name of owner.

Part B is yet to be prepared. They have requested for the draft format from NERLDC. It was assured that, upon receiving the formats, from SLDC Assam/Arunachal Pradesh, NERLDC would forward the same.

SLDC Nagaland had asked for final date of submission of the signed DPRs. NERLDC requested that maximum of two weeks' time can be permitted as the whole process from PSDF Approval to Tendering will take a great amount of time.

3.6 Meghalaya

SLDC Meghalaya informed that Backup SLDC location is finalized and they are preparing Part B. They have also requested for the draft format from NERLDC. Upon receiving the formats from SLDC Assam/Arunachal Pradesh, NERLDC will forward the same.

Regarding Part A, SLDC Meghalaya informed that few days' will be required for signing the DPR.

They also raised the query regarding "RTU Maintenance not included in the L&T quotation". To which it was clarified that, an email reply has been received from the Vendor that the same is included in the budgetary estimated amount. Reply email has been shared with all the States on 1st May'24 for inclusion in the DPRs.

3.7 Tripura

Regarding the Part A, SDLC Tripura has mailed some queries to NERLDC. CGM (SL), NERLDC communicated that the reply on their queries will be provided after discussion with CC-Engineering, GRID-INDIA.

Regarding Part B, SLDC Tripura informed that the Civil Department is looking after the same and will be done in a week's time.

Member Secretary, NERPC requested all SLDCs to submit the DPRs within 2 (two) weeks' time.

The meeting ended with thanks to all the participants and subsequent updates from the states will be taken in the next NETeST Meeting.

The list of Participants in the meeting are attached below:

SI No.	Name	Organization	Designation	Phone No	Email ID
1	K B Jagtap	NERPC	Member Secretary		kb.jagtap@gov.in
2	Amaresh Mallick	NERLDC	ED, NERLDC	9436302720	amareshmallick@grid-india.in
3	S P Barnwal	NERLDC, Guwahati	CGM, SL	9433041812	spbarnwal@grid-india.in
4	Lalawmpuia Chawngthu	SLDC Mizoram	AE	8730843706	awmach.9@gmail.com
5	Shampa Sen	SLDC Tripura, TPTL	Sr. Manager	9436120263	smpsen@rediffmail.com
6	N Romeo Singh	SLDC Manipur	Deputy Manager	9612657280	romeo.ningombam@gmail.com
7	Steffi Okram	SLDC Manipur	Manager	8974724715	steffiokram@gmail.com
8	D J Lyngdoh	MePTCL	SE	9863063375	david.jeremy6@gmail.com
9	M K War	SLDC, Meghalaya	EE	9436116496	eesmsldcmeg@gmail.com
10	Y Iakai	SLDC, Meghalaya	AEE	9402133552	iakaiyomon@gmail.com
11	E.Pongmei Phom	SLDC Nagaland	SDO	8132862504	pongmeinew1@gmail.com
12	V.Lalhmingliana	SLDC Mizoram	JE	9612763052	v.mahminga@gmail.com
13	Lalremruata Sailo	SLDC Mizoram	JE	9612614372	
14	H.Lalruatkima	SLDC Mizoram	Sr.EE	9862925462	krhlondo71@gmail.com
15	Gargi Dutta	NERLDC, Shillong	CM	9436335231	gargi@grid-india.in
16	Shakti Mayank Singh	NERLDC, Guwahati		8299085576	Shaktimayank@grid-india.in
17	Gaurav Bhattacharjee	NERLDC, Guwahati	AM	9402304210	
18	Toushita Jigdung	SLDC, Asaam	DGM(logistic)	9707134351	
19	Ranjan Goswami	SLDC, Asaam	AGM		
20	Rupjyoti Das	SLDC, Asaam	DM		
21	Nilotpal Bhattacharjee	SLDC, Asaam	AM		
22	Palash Jyoti Borah	NERLDC, Guwahati	Manager	8761093397	palash14.india@grid-india.in
23	P Tiakaba Yimchunger	SLDC Nagaland	JE	8974020151	tiaquenger@gmail.com
24	Purik Buchi	SLDC, Arunachal Pradesh		9366118384	

REGIONAL COMMUNICATION AUDIT REPORT
--

General Information:	
-----------------------------	--

1	Substation Name	
2	SS Voltage level	
3	Date of commissioning of the substation	
4	Region & State / Auditee	
5	Audit Date	
6	Name of the Utility which owns the SS	

Details of Audit Team Members :			
--	--	--	--

SL	Name	Designation	Organization
1			
2			
3			
4			

Attached Documents, if any		
-----------------------------------	--	--

SL	Name of the document	Original / Signed / Copy
1		
2		
3		
4		
5		
6		
7		
8		
9		
10		
11		
12		
13		
14		
15		
16		
17		

Communication Channels and Equipments Audit Format

(A) List of channels in usage for data (64 kbps, 104, PMU, VC, 101) / Voice / Protection circuits / Others :

Sl	Description (64 kbps, 104, PMU, VC, 101) / Voice / Protection circuits / Others)	Source	Destination	Channel Routing	Ownership details of terminal equipment / Links
1					
2					
3					
4					
5					
6					
7					
8					

(B) List of terminal communication equipments :

Sl	Name of Station	Equipment Type (SDH / PDH / Radio / VSAT / EPABX)	Make / Model	Ownership
1				
2				
3				
4				
5				
6				
7				
8				

(C) Communication System Details :

I. SDH Equipment

(1) Card Details :

Slot No	IP Address & Path / Direction Name	Card Details	Place a ✓ mark if on usage, else Write as "Spare"	Whether Card is healthy / Faulty ? (H / F)	Cards Redundancy available (Yes / No)	Power Supply Card / Optical Card (Yes / No)	MSP configured ? (Yes / No)	Action Plan for faulty cards	Other Information, if any
1									
2									
3									
And so on									

(2) Whether equipment is time synchronized : Yes / No

If Yes, how is it being done ?

(3) Failures during last Fin. year / since last Audit :

Particulars	Number of failures of Card / Power Supply	Reason for failures	Measures taken for rectification
Card		(i) (ii) (iii)	(i) (ii) (iii)
Power Supply		(i) (ii) (iii)	(i) (ii) (iii)

(4) Configuration of the Node :

Name of Equipment	Number of Nodes	Number of directions	Name of Directions	Number of links down, with details	Details of corrective action, if any, taken

(5) Preventive maintenance schedule and its compliance :

Date of Last Preventive maintenance	Maintenance carried out as per schedule ? (Yes / No)	Whether all the defects have been attended ? (Yes / No) Give details

II. PDH Equipment

(1) Card Details :

Slot No	IP Address	Card Details	Place a ✓ mark if on usage, else Write as "Spare"	Whether Card is healthy / Faulty ? (H / F)	Cards Redundancy available (Yes / No)	Power Supply Card / Optical Card (Yes / No)	MSP configured ? (Yes / No)	Action Plan for faulty cards	Other Information, if any
1									
2									
3									
And so on									

(2) Whether equipment is time synchronized : Yes / No

If Yes, how is it being done ?	

(3) Failures during last Fin. year / since last Audit :

Particulars	Number of failures of Card / Power Supply	Reason for failures	Measures taken for rectification
Card		(i) (ii) (iii)	(i) (ii) (iii)
Power Supply		(i) (ii) (iii)	(i) (ii) (iii)

(4) Configuration of the Node :

Name of Equipment	Number of Nodes	Number of directions	Name of Directions	Number of links down, with details	Details of corrective action, if any, taken

(5) Preventive maintenance schedule and its compliance :

Date of Last Preventive maintenance	Maintenance carried out as per schedule ? (Yes / No)	Whether all the defects have been attended ? (Yes / No) Give details

III. OPGW / Optical Fibre Details

Number of Directions	Name of Direction	No. of Pairs	No. of Fibers used	No. of spare & healthy Fibers	Unarmoured cable laid within PVC/Hume duct pipe ?	Fibre Count in OPGW ? Whether matching with Approach cable to FODP ?	Overall Optical Fibre Path Attenuation (dB/km)	Power Received	Conformation to Compliance of CEA Standards

IV. Healthiness of Auxiliary System :

(1) Details of 2 independent Power Sources :

Source	Commissioning Date	Battery Back up (Hour)	Battery capacity (AH)	Supply Voltage (V)	Healthiness of Battery (Yes / No)	Make of Charger	Charger Capacity (A)	Periodicity of Maintenance Schedule	Date of Last 2 Actual Maintenance carried out	Remarks
1										
2										

(2) Conformation to Compliance of CEA Standards :

V. Healthiness of Earthing of each equipment :

Sl	Equipment	Status on Healthiness of Earthing

VI. Details of Voice communication available between Sub-station and Control Centre :

Sl	Voice communication (Sub-station - Control Centre)	Status on Healthiness of Voice communication	Healthiness of air-conditioning of communication room as per OEM recommendation

VII. PLCC Details :

Number of Panels	Make and Model	Direction	Frequency (Tx & Rx) KHz	Status on Healthiness	Last preventive maintenance		Details of defects, if any, attended	Status of Availability of Spares	Conformation to Compliance of CEA Standards
					Schedule	Actual			

VIII. Radio Communication Details :

Number of Equipments	Make and Model	Status on Healthiness	Last preventive maintenance		Details of defects, if any, attended	Status of Availability of Spares	Conformation to Compliance of CEA Standards
			Schedule	Actual			

IX. Data Retention : (i) **Earliest Date of availability of data :** _____
 (ii) **Historical data availability :** _____ days.

X. Control Command Delay : (i) **Time delay in seconds from Control Centre for SCADA :** _____ Seconds
 (ii) **Time delay in seconds from Control Centre for WAMS :** _____ Seconds

XI. Wide Band Network : (i) **Absolute channel delay in protection applications :** _____ ms
 (ii) **Channel delay asymmetry in protection applications :** _____ ms
 (iii) **Switching Time delay to alternate path/route during failure of one path :** _____ ms

XII. Any other information :

**Audit Team Member
NERPC**

**Audit Team Member
Co-Ordinator**

**Audit Team Member
PGCIL (Internal / External)**

**Audit Team Member
State (Internal / External)**

North Eastern Regional Power Committee

MINUTES OF THE SPECIAL REVIEW MEETING

NE-TeST

Date : 07th March, 2024 (Thursday)

Time : 11:00 Hrs

Venue : “Hotel Royale de’ Casa”, Guwahati.

The List of Participants is attached at **Annexure – I**.

Shri K. B. Jagtap, Member Secretary, NERPC welcomed all the participants. He informed that the following agenda items needs urgent attention and deliberation.

A. ITEMS FOR DISCUSSION

A.1 Establishment of redundant fibre path between NERLDC and NEHU for reliability of power system communication link till RLDC.

On 05-01-2023 and 06-01-2023, there were two incidents of fibre cut between NERLDC and NEHU, during the incident all communications links, such as internet, all ULDC links of ICCP, URTDSM, VOIP, RTUs and all POWERTEL links catering the functionality of NERLDC real time system were affected. Consequently, NERLDC control room was not having any data of grid station which led RLDC to operate grid blindly. Due to outage of this link SLDC and NLDC were also not able to receive data from NERLDC. This 24-core fibre currently runs partially as OPGW on 132 kV NEHU-Kheliriat line and partially as UGFO cable. The fibre is under the ownership of POWERTEL & ULDC has been allotted some pair of fibres from it.

Considering the critical functions of LDCs, it is requested to ULDC-POWERGRID to lay 24 core FIBRE between NERLDC Shillong and NEHU, which should be in physically different path to that of POWERTEL fibre and complete ownership of new fibre should be with ULDC-POWERGRID.

During 24th NETeST Meeting, the forum requested NERTS to include this link in the reliable communication project as this is a very important link in the ULDC network under the head of central sector links. Further, Member Secretary, NERPC suggested the forum to carry out a separate meeting between MePTCL, POWERGRID-ULDC,

Minutes of Special Review Meeting held on 7th March, 2024
POWERTEL, NERLDC and NERPC to discuss the issues raised by MePTCL regarding Powertel link.

During 25th NETeST meeting, as per request of the forum ULDC-POWERGRID agreed to lay 24 core UG FIBRE between NERLDC Shillong and 132kV NEHU-Kheliriat line- I Tower no.25 under Reliable Communication Scheme.

During the Special NETeST Sub Group Meeting held on 31st May, 2023, MePTCL informed the forum that they desire to BOO (Build – Own – Operate) the OPGW in their Transmission lines. In this regard, POWERGRID informed that due to system constraint, if required, the 7.532KM NEHU – T25 link can be decapitalized subject to TCC/RPC approval. CTU informed the forum that the ownership and maintenance accountability of these links has to be established before such proposed transfer.

In 27th NETeST meeting, it was decided that separate meeting shall be conducted.

Deliberation of the forum:

(a)132 kV NEHU – Khliehriat CKT-I

NERLDC informed that data to NERLDC for grid operation was to be ensured via 12F of 132 kV NEHU – Khliehriat CKT II (connected in Tower No. 23) as a main path and 132 kV NEHU – Khliehriat CKT-I (Connected in Tower No. 25) as a protection path. However, Under MW vacation project, 7.532KM OPGW-24F has been laid from 132 kV NEHU S/s to Tower No. 25 of 132 kV NEHU – Khliehriat CKT-I and in the 24th TCC/RPC meeting, approval was accorded to ULDC-POWERGRID to lay 24 core UG FIBRE between NERLDC Shillong and 132 kV NEHU-Kheliriat line I Tower 25.

POWERGRID informed that the work in this regard has been initiated. However, POWERGRID mentioned that further NCT approval may be required for carrying out the UGFO works from T-25. NERLDC informed that POWERTEL has installed an ADSS cable for fiber connectivity between T-25 of the 132 kV NEHU-Mawlyndep-Mustem-Khliehriat line (Ckt-I) and NERLDC, Shillong for their commercial purpose and has not provided any fiber to NERLDC for ULDC purpose/application. The forum asked POWERTEL to share the copy of approval for the ADSS cable installed by them within a month to NERLDC /NERPC. POWERTEL agreed to share the copy of approval for the ADSS cable installed by them. POWERTEL also informed the forum that significant losses were being observed in the ADSS cable, limiting its full utilization.

MePTCL also informed that they would like to install and commission a 48F link in the NEHU-Mawlyndep-Mustem-Khliehriat CKT I line under State Reliable Scheme 90:10 or any other government scheme. MePTCL submitted the followings (for the necessity and benefits of installing 48F in lieu of 24F):

- (a) The cost of 48F and 24F are comparable and varies around 10%- 20%
- (b) Additional no. of fiber will ensure, sufficient channel availability for ULDC, SPS, Digital Protection, etc. i.e., it will also enhance the system reliability.
- (c) After using the fibers for system reliability, MePTCL can use the balance fiber for commercial purpose for additional revenue from their existing infrastructure for financial viability.

AEGCL also informed the forum that they also desire to use the fiber installed in their Transmission infrastructure for deriving additional revenue as the present revenue shared with them is too low. POWERGRID informed that the as per CERC regulations, sharing of benefits is being done. CTUIL is the nodal authority which ensure sharing of benefits is being reflected in the bills. MePTCL referred to the special meeting held on 31-May-2023 in NERPC and informed that they are yet to receive the details of payments/benefits accrued from telecom business towards reduction in POC charges / transmission charges for Meghalaya (utilization of the ULDC OPGW link by POWERTEL). AEGCL also requested that Assam also wants the same information. The forum suggested that CTUIL should furnish the details as requested by MePTCL & AEGCL within a month.

The forum noted that 7.532 KMs of 24F OPGW is existing between 132 kV NEHU S/s and Tower 25 of 132 kV NEHU-Kheliriat line I. In this connection, POWERGRID informed that the 7.532 KMs of OPGW was commercialized in 2014 and 10 years of useful life have been completed. After DOCO of the proposed 48F from NEHU-Mawlyndep-Mustem-Khliehriat CKT I, this section needs to be decapitalized. The forum opined that implementation of the proposed 48F by MePTCL will require its inherent time (as it includes DPR preparation and subsequent internal approval followed by submission and approval of PSDF or any other funding agency and its subsequent project implementation), as such there may not arise the need for decapitalization of the 7.532 KMs of 24F OPGW implemented by POWERGRID under MW vacation. However, in case the DPR is finalized and the project is awarded before completion of useful life of the OPGW, the same has to be decapitalized and the necessary charges need to be reimbursed to POWERGRID.

The forum also noted that the proposal of MePTCL for implementing a 48F link in the NEHU-Mawlyndep-Mustem-Khliehriat CKT I, approval obtained in the 24th TCC/RPC meeting to lay 24 core UG FIBRE between NERLDC Shillong and 132 kV NEHU-Kheliriat line I Tower 25 shall require modification and accordingly it can be taken in next RPCs meeting. In this connection, NERLDC proposed the following fiber distribution (**Attached as Annexure A-1**):

SN	From	To	Number of Fiber
1	NEHU	NERLDC	24F
2	NEHU	Mawlyndep	24F
3	NERLDC	Mawlyndep	24F
4	Mawlyndep	Mustem-Khleiriat	48F

NERLDC also requested for redundant links to NERLDC, Shillong via 400 kV Silchar-Byrnihat Line and 220 kV New Shillong S/s.

NERLDC informed the forum that Regulation 12 of Communication System for inter-State transmission of electricity Regulations, 2017 mandates “All users of CTU, NLDC, RLDCs, SLDCs, STUs shall maintain the communication channel availability at 99.9% annually: Provided that with back up communication system, the availability of communication system should be 100%”. MePTCL assured the forum that the regulation shall be followed strictly and maintenance of the OPGW would be accorded top priority.

After detailed deliberation, the forum agreed to the following (subject to approval of TCC/RPC Forum):

1. **48F OPGW from NEHU to Khliehriat:** MePTCL to propose 48F OPGW on 132 kV NEHU-Mawlyndep-Mustem-Khliehriat line under the State reliable communication Scheme or other suitable schemes. MePTCL to lay and subsequently maintain the link as well.
2. **From T-25 to NERLDC:** POWERGRID to lay and maintain the underground 48F cable under the ongoing reliable communication scheme out of which 24F will be connected to NEHU and the balance 24F to be connected with Mawlyndep. Further, approval shall be taken in the forthcoming TCC/RPC meeting for upgrading the approved 24F to 48F.
3. **Establishment redundant links to NERLDC, Shillong:** The Forum requested POWERGRID-ULDC to survey and check the feasibility of establishing redundant

Minutes of Special Review Meeting held on 7th March, 2024
links to NERLDC, Shillong via 400 kV Silchar- Byrnihat Line and 220 kV New Shillong S/s.

(b) 132 kV NEHU – Khliehriat CKT-II

NERLDC informed the forum that 12F OPGW between NEHU to Khliehriat was laid in ULDC Phase-1 and it has completed its useful life of 15 years. As such replacement of the same has become essential. After detailed deliberation, the forum agreed to the following:

1. **48F OPGW from NEHU to Khliehriat:** The Forum suggested that the OPGW should be upgraded to 48F by POWERGRID in consultation with CTU.
2. **From T-23 to NERLDC:** 12F Underground cable will be upgraded to 24F cable which is already part of the Reliable communication scheme.
3. **From T-23 to NEIGRIHMS:** 24F OPGW is already laid under the NER FO scheme which will be connected to NEHU and Khliehriat.
4. The proposed distribution of the fiber shall be as follows:

SN	From	To	Number of Fiber
1	NEHU	Khliehriat	24F
2	NEHU	NERLDC	12F
3	NERLDC	Khliehriat	12F
4	NEHU	NEIGRHIMS	12F
5	NEIGRHIMS	Khliehriat	12F

5. CEA has constituted a committee under the chairmanship of Member (Power System), CEA for formulating comprehensive guidelines for the usage and sharing of optical fibers (OPGW) for power system applications. NER will follow the guidelines approved by the committee.

The forum noted as above.

Action: POWERTEL, MePTCL, POWERGRID-ULDC, CTUIL, NERLDC & NERPC.

A.2 Replacement of FO link for “NERLDC Shillong – NEHU”, “132 kV Kahilipara – Sarusajai” and “132 kV Kahilipara – Umiam Stg. III – Umiam Stg. I – NEHU”.

Grid-India stated that in the 23rd TCC and NERPC meeting, TCC forum recommended for replacement of OPGW with 24 Fiber for NERLDC Shillong – NEHU”, “132 kV Kahilipara – Sarusajai” and “132 kV Kahilipara – Umiam Stg. III – Umiam Stg. I – NEHU” after RPC and NCT approval. This proposal for replacement shall be substantiated with test report of fiber healthiness. But test report is not available with

Meghalaya SLDC as the links have not been handed over to them by POWERGRID. POWERGRID stated that automatic handing over of the link ownership takes place after completion of fifteen years.

Further deliberations were held regarding ownership and maintenance of the said links. CTUIL stated that since these links are being used for ISTS data & voice communication and this communication shall be kept intact. In view of this CTU requested POWERGRID to clarify the entity who is maintaining the above said lines.

Deliberations in 4th CPM: POWERGRID told that this link contains critical ISTS data and this is the only path for NERLDC connectivity with only 12 Fibers. POWERGRID shared the connectivity diagram of NERLDC (as shown in figure below) and explained the criticality of these links. POWERGRID told that if Meghalaya is ready to maintain and takeover the link they have no issue in handing over these links.

However, GRID-INDIA informed that one of the above links i.e 132 kV Kahilipara – Sarusajai section belongs to Assam which is not vital for NERLDC connectivity and replacement of OPGW on this link shall be considered separately in consultation with Assam. Further, GRID-INDIA stated that 132kV NEHU-Umiam-I-Umiam -III is critical for Grid operation as most of the NERLDC data and AGC data is being routed through this path. In view of this, GRID-INDIA requested CTU for approval for laying of OPGW on these lines to be obtained from NCT. CTU suggested OPGW replacement on all these links may be carried out by single party considering reliability of backbone connectivity to NERLDC. CTU clarified that for approval of OPGW replacement on these lines under ISTS scheme from NCT, the replacement of OPGW shall be substantiated with test report of fiber healthiness which was asked for in the 23rd TCC and NERPC meeting also.

POWERGRID also intimated that Meghalaya is also implementing OPGW on Khleiriat-NEHU section which provides path redundancy for NERLDC. CTU suggested POWERGRID to check whether 48 Fibers can be laid on the “NERLDC Shillong – NEHU” and “132 kV Kahilipara – Umiam Stg. III – Umiam Stg. I – NEHU” paths so that fibers can be shared for ISTS and STU purposes. CTU requested POWERGRID to provide test-report of fiber healthiness of these links so that further review/approval in NETeST/TCC/NERPC & subsequently NCT may be taken up.

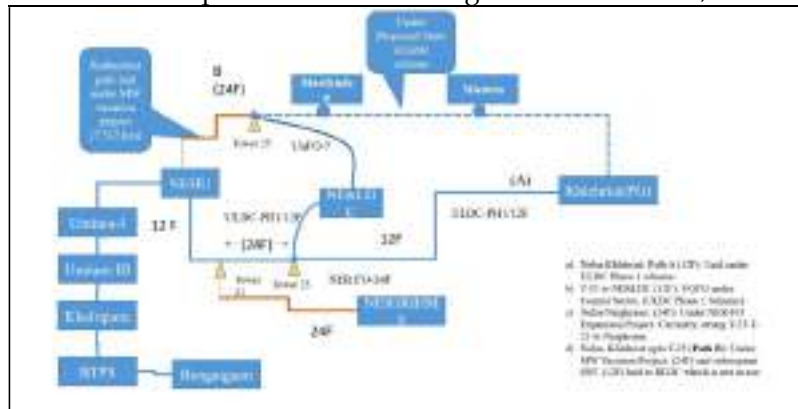

Connectivity diagram of NERLDC

Deliberations in 26th NETeST meeting: MePTCL informed the forum that they desire to BOO (Build – Own – Operate) the OPGW in their Transmission lines. POWERGRID – ULDC informed the forum that NEHU – Khlehriat link has been laid in ULDC Phase 1. They are also laying a 12F link from T23 of Nehu – Khlehriat to NERLDC. POWERGRID – ULDC also informed that under MW vacation project, a 7.532KM 24F NEHU – T25 link was laid; whereas T25- Mawlyndep – Mustem – Khlehriat link was to done under State reliable scheme. However, as MePTCL has desired to BOO these links, POWERGRID is ready to handover these link to MePTCL on a mutually agreeable date provided maintenance of these links are also undertaken by MePTCL. POWERGRID also informed that due to system constraint, if required, the 7.532KM NEHU – T25 link can be decapped subject to TCC/RPC approval. CTU also informed the forum that the ownership and maintenance accountability of these links has to be established before such proposed transfer.

In 27th NETeST meeting, it was decided that separate meeting shall be conducted.

Deliberation of the forum:

- (a) **Replacement of FO link for “NERLDC Shillong – NEHU”** - discussed in Agenda A.1.
- (b) **Replacement of FO link for “132 kV Kahilipara – Sarusajai”** – The forum noted that as this AEGCL’s section is not vital for NERLDC connectivity so replacement and maintenance of OPGW on this section shall be considered by State/STU.
- (c) **Replacement of FO link for “132 kV Kahilipara – Umiam Stg. III – Umiam Stg. I – NEHU”** – CTUIL via email informed that as per the discussion held in 5th CPM meeting of CTUIL, it was suggested in the forum that 48 fibers may be laid and maintained by POWERGRID on Meghalaya owned lines “132 kV Kahilipara – Umiam Stg. III – Umiam Stg. I – NEHU”. Out of 48 fibers, 24 fibers

Minutes of Special Review Meeting held on 7th March, 2024
will be for ISTS use and the rest 24 fibers for state purpose. This was agreed in the forum. However, Meghalaya stated that they will have to take consent from their management for the said proposal.

Meghalaya (MePTCL) informed that their management has approved the laying and maintenance of 48 fibers by POWERGRID in “132 kV Kahilipara – Umiam Stg. III – Umiam Stg. I – NEHU” subject to the use of 24 fibers for ULDC/System requirement and balance for their own commercial purpose. However, POWERGRID opined that the usage and sharing of the fibers is to be done as per CEA/CERC guidelines/regulations.

Additionally, MePTCL has made a request to connect the 132 kV Kahilipara – Umiam Stage III line at 132 kV Umtru for improved connectivity. The forum agreed to the same and endorsed the establishment of the link as 132 kV Kahilipara – Umtru - Umiam Stg. III – Umiam Stg. I – NEHU. Further discussions regarding the distribution of OPGW between ULDC-POWERGRID and MePTCL to take place in subsequent meetings.

AEGCL highlighted the critical nature of the 132 kV Kahilipara – Umtru OPGW link for Assam, NERLDC, and Meghalaya. AEGCL requested that the OPGW over the 132 kV Sarusajai – Umtru line to be considered as a redundant path. The forum has acknowledged the same and decided to deliberate on it in forthcoming meetings.

The forum noted as above.

Action: MePTCL, AEGCL, POWERGRID-ULDC, CTUIL, NERLDC & NERPC.

Any other item:

A.3 Connectivity of NERLDC Guwahati with Sarusajai and Umiam bypassing Kahilipara for its redundancy.

During a meeting held on August 8th, 2022, involving Communication-AEGCL, SLDC Assam, NERLDC Grid-India, and ULDC-POWERGRID, several decisions were made. It was agreed that POWERGRID would lay two 24-core fiber optic cables from NERLDC Guwahati to Gantary of Kahilipara. At Gantary, a Joint Box would be installed, facilitating the connection of one cable from NERLDC to the Sarusajai direction and the other cable to the Umtru direction.

Additionally, it was decided that AEGCL would upgrade the existing 12-core Optical Ground Wire (OPGW) over the 132 kV Kahilipara – Sarusaji link to a 24-core OPGW.

Deliberation of the sub-Committee:

MS, NERPC advised NERLDC to put it as an agenda item in the forthcoming NETeST meeting for further discussion and consideration.

The Sub-Committee noted as above.

Action: NERLDC.

Annexure-I

List of Participants in the of Special Review Meeting held on 7th March, 2024

SN	Name & Designation	Organization	Contact No.
1	Sh. Arup Sarmah, AGM, SLDC, AEGCL	Assam	09707854367
2	Sh. J. Hynniewta, Director (T), MePTCL	Meghalaya	-
3	Sh. D. J. Lyngdoh, SE-I (Trans), MePTCL	Meghalaya	-
4	Sh. B. Narry, EE, MePTCL	Meghalaya	-
5	Sh. C. W. Chen, AEE, MePTCL	Meghalaya	09863093311
6	Sh. Amaresh Mallick, ED	NERLDC	09436302720
7	Sh. S. Mondal, CM	NERLDC	09433041851
8	Sh. Sakal Deep, AM	NERLDC	09774528218
9	Sh. Anupam Acharya, CM	PGCIL	-
10	Sh. M. K. Baruah, Sr.GM	PGCIL	-
11	Sh. Kamlesh Baishya, AM	PGCIL	-
12	Smt. Indrani Kakati, Sr. DGM	POWERTEL	-
13	Sh. Hiranmoy Duwarah, DM	POWERTEL	-
14	Sh. K. B. Jagtap, Member Secretary	NERPC	-
15	Sh. Rajib Das, AEE	NERPC	09954947474



Proposed Solution of NEHU-NERLDC- Khliehriat Ckt-1 & Ckt-2

-By NERLDC

NEHU-NEGIRHIMS Redundancy

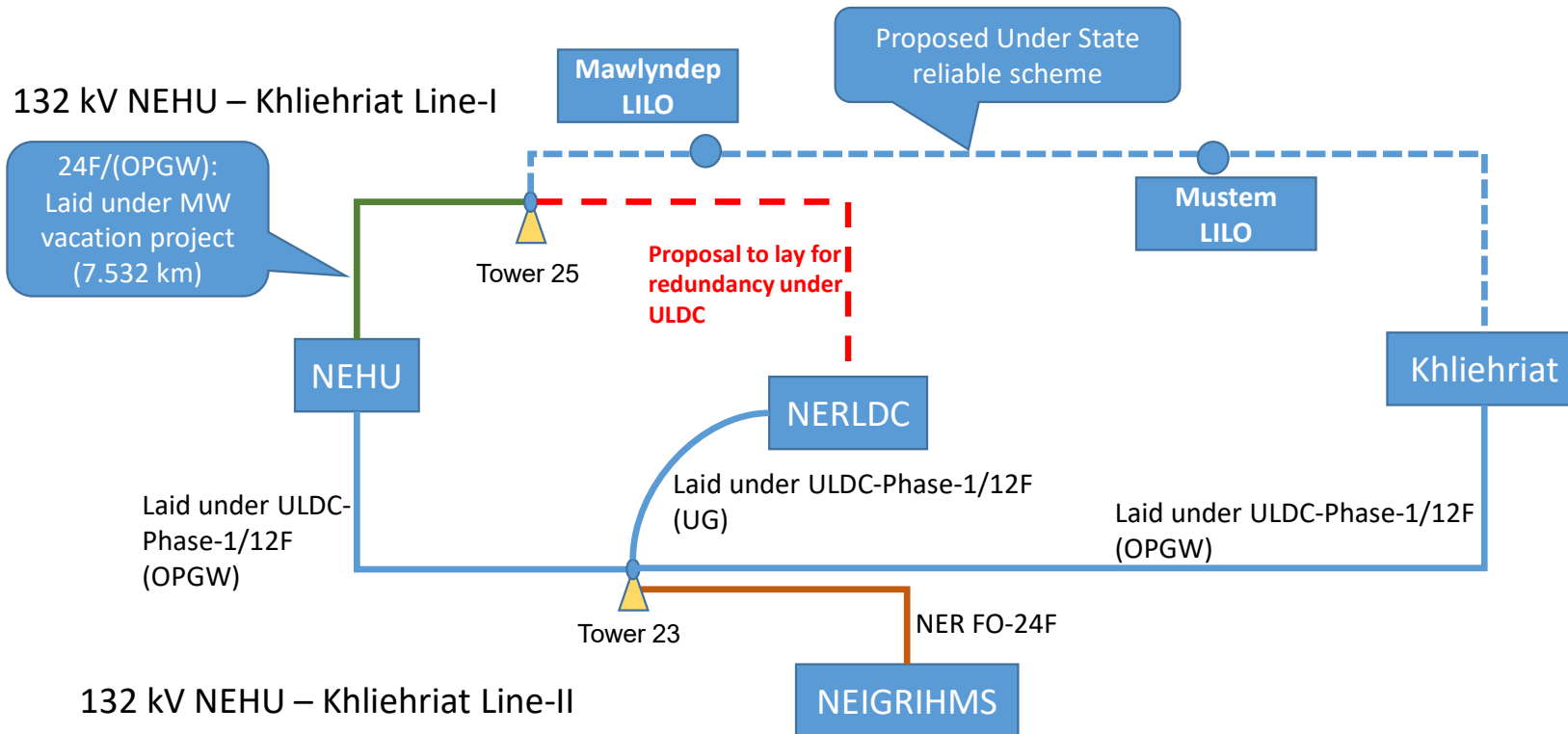

- NEHU to NEIGRIHMS (9 km) – approved under NER FO Expansion project.
 - Partly laid between NEIGRIHMS to Tower 23 i.e. 1.8 km at present.
- “Tower 23” to NERLDC underground 24 fibres of already approved in Reliable Communication Scheme of POWERGRID

NEHU-NEGRHIMS Redundancy

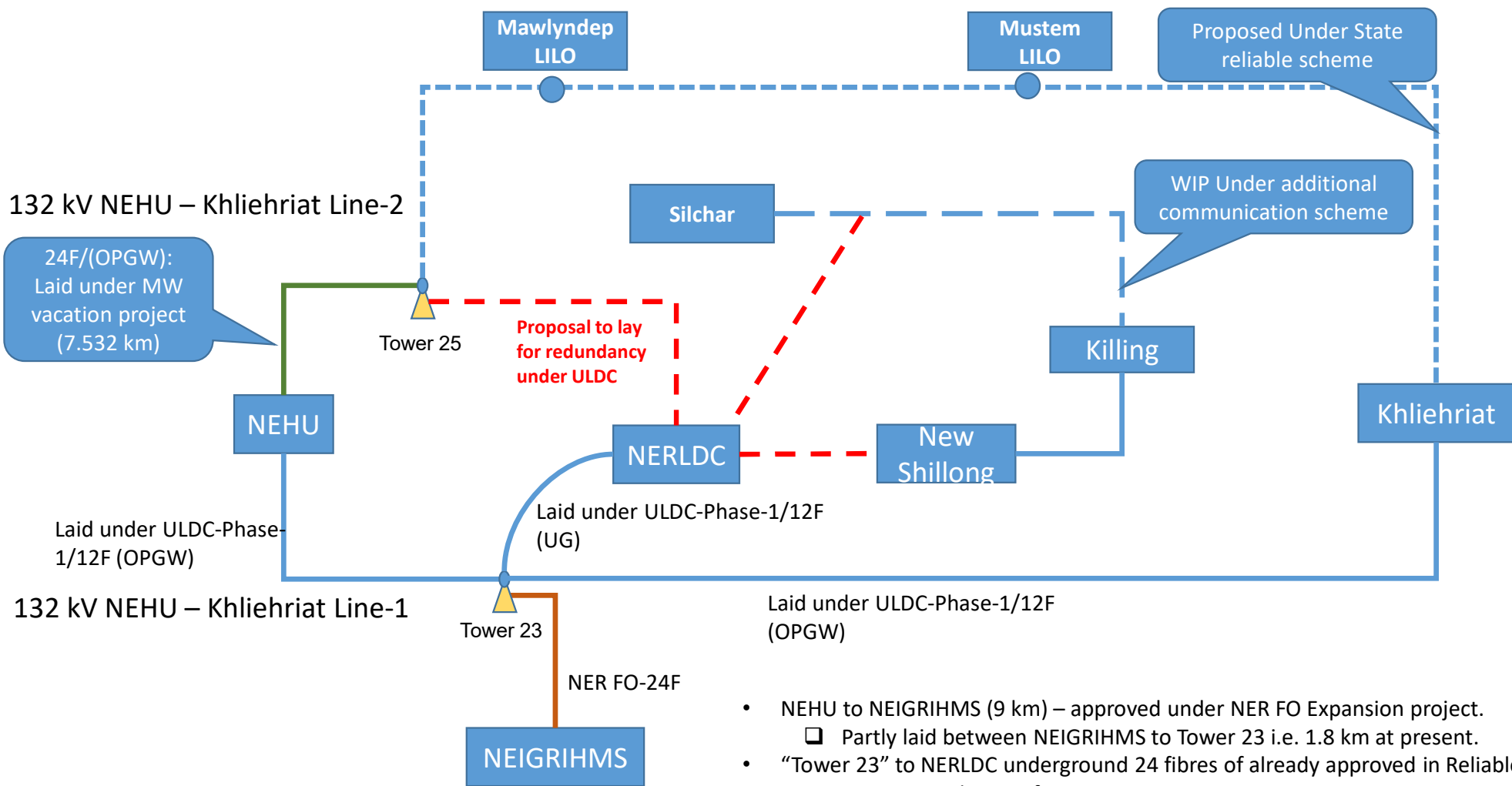

132 kV NEHU – Khliehriat Line-2

24F/(OPGW):
Laid under MW
vacation project
(7.532 km)

Proposed Under State
reliable scheme

WIP Under additional
communication scheme

Proposal to lay
for redundancy
under ULDC

Laid under ULDC-Phase-
1/12F (OPGW)

132 kV NEHU – Khliehriat Line-1

Laid under ULDC-Phase-1/12F
(UG)

Laid under ULDC-Phase-1/12F
(OPGW)

NER FO-24F

- NEHU to NEGRHIMS (9 km) – approved under NER FO Expansion project.
 - Partly laid between NEGRHIMS to Tower 23 i.e. 1.8 km at present.
- “Tower 23” to NERLDC underground 24 fibres of already approved in Reliable Communication Scheme of POWERGRID

Solution for 132 kV NEHU – Khliehriat Line-I

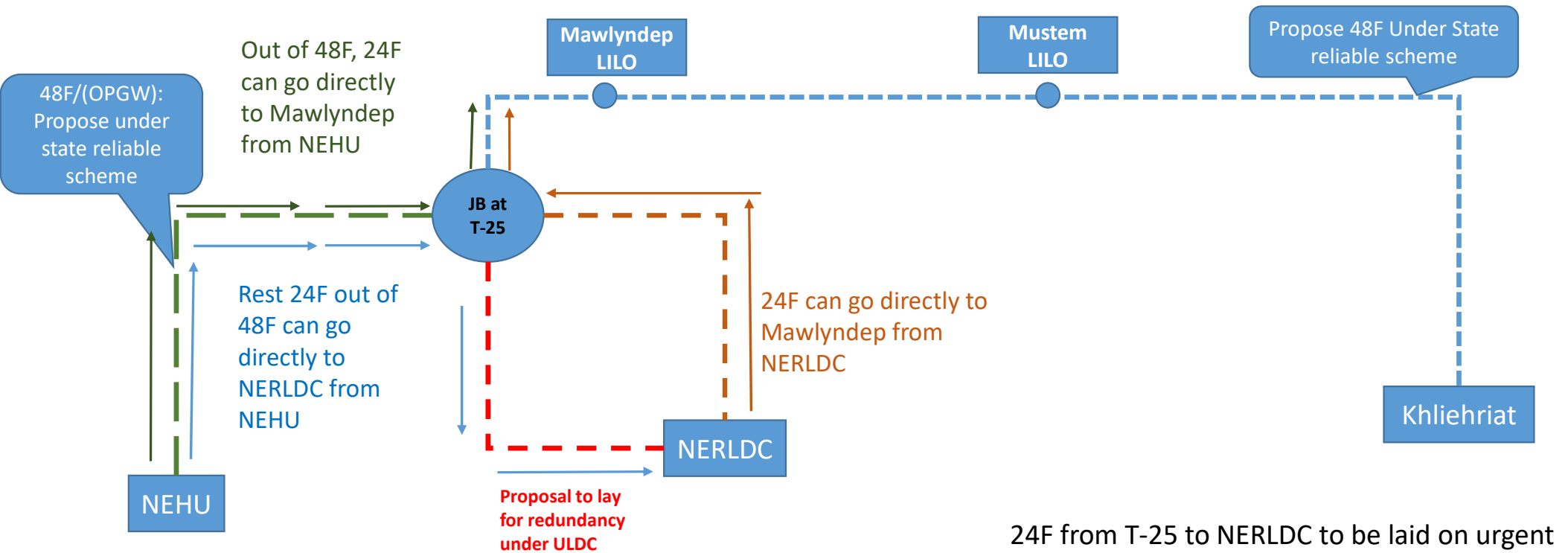

- Need to decap existing 7.532 KMs of OPGW laid by PGCIL

--- 24F from T-25 to NERLDC to be laid on urgent basis by ULDC-POWERGRID as decided in 25th NETeST meeting. This will be connected to NEHU as interim basis using NER-MW vacation OPGW

--- Additional 24F from T-25 to NERLDC which will be connected to Mawlyndep-Mustem-Khliehriat

Solution for 132 kV NEHU – Khliehriat Line-I (in table)

Sl. No.	From	To	Number of Fiber
1	NEHU	NERLDC	24F
2	NEHU	Mawlyndep	24F
3	NERLDC	Mawlyndep	24F
4	Mawlyndep	Mustem-Khleiriat	48F

Solution for 132 kV NEHU – Khliehriat Line-II

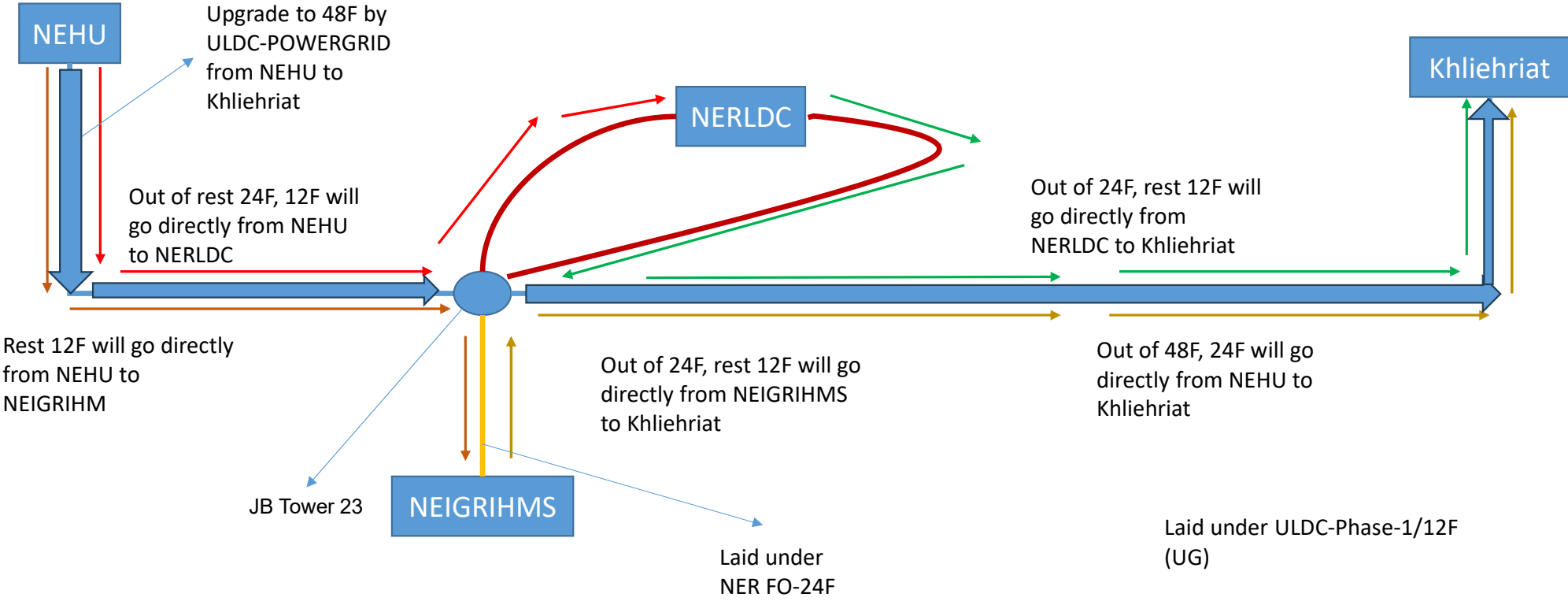

Solution for 132 kV NEHU – Khliehriat Line-II (in table)

Sl. No.	From	To	Number of Fiber
1	NEHU	Khliehriat	24F
2	NEHU	NERLDC	12F
3	NERLDC	Khliehriat	24F
4	NEHU	NEIGRHIMS	12F
5	NEIGRHIMS	Khliehriat	12F

Urgent Request of NERLDC

- Lay 48F Under ground fiber from T-25 of 132kV NEHU-Mawlyndep-Mustem-Khliehriat-2 to NERLDC.
- Connect 24F from NEHU to NERLDC over 132kV NEHU-Mawlyndep-Mustem-Khliehriat-2 to NERLDC.
- Above arrangements should be done as interim basis till MePTCL lay 48F from T-25 to Mawlyndep-Mustem-Khliehriat and NEHU to T-25.
- Decapitalisation of 7.532 KMs 24F-OPGW from NEHU to T-25 to be after project execution phase.

Thank you

Comprehensive T&D-Arunachal Pradesh and NERPSIP. Map is required because many stations mentioned in the scheme above are connected with existing ISTS/ISGS nodes.

NERLDC had provide the necessary details of Comprehensive T&D-Arunachal Pradesh and NERPSIP to CTUIL via email dated 23rd June 2023.

CTUIL is requested to update about the preparation of the communication map.

Members may deliberate.

Deliberations: As per point number 3.0 above.

5.0 VSAT project for North-Eastern Region (by NERLDC)

Considering the various geographical factors, technological factors and successful pilot projects, it was decided in various NERPC forums that a special project of VSAT technology will be envisaged for all NER states. Subsequently, DPR was submitted by each state and put up to Techno-economic Sub-group (TSEG) committee of PSDF secretariat, where it was deliberated to put the OPGW and VSAT in same DPR on request of CTUIL.

CTUIL is requested not to keep OPGW and VSAT technology as part of same DPR.

Members may deliberate.

Deliberations:

GRID-INDIA stated that DPR of VSAT and OPGW for PSDF funding should not be combined as suggested in recent TSEG group meeting. Forum agreed that both technologies are completely different. GRID-INDIA further stated that the tenders of VSAT and OPGW are never clubbed together and vendors handling the two technologies of communication are separate with different expertise. The VSAT technology has been tested on Extended-C band in pilot projects conducted in NER and the same is under operation in around 13 nos. of stations (incl. 3 stations of POWERGRID) located in Arunachal Pradesh. The approvals for adoption of this technology had already been taken in TCC/NERPC Board meeting held in March 2022 at Guwahati. In order to analyse the matter further, CTU requested GRID-INDIA to share minutes of meeting of the TSEG held in March-2023 and CTU will revert after getting the details. GRID-INDIA agreed to provide the same.

6.0 Additional FOTE at all AGC operated generating stations in North Eastern region, in view of resource disjoint and criticality of AGC operation for grid operation purpose (by NERLDC)

Additional FOTE at all AGC operated generating stations in North Eastern region, in view of resource disjoint and criticality of AGC operation for grid operation purpose. Failure or single equipment may lead to disruption in AGC operation.

Following AGC Locations may be considered for additional FOTE:

- a. Bongaigaon – AGC Operational
- b. Loktak – AGC Operational
- c. Kopili – AGC under implementation
- d. Khandong – AGC under implementation
- e. Kopili Stage 2 – AGC under implementation
- f. Kathalguri – AGC under implementation

- g. Doyang HEP – AGC under implementation
Members may deliberate.

Deliberations: GRID-INDIA informed the forum that five nos. of new AGC stations as stated above are planned for implementing the AGC in NE Region as per CERC order and these stations shall be operational for AGC in next three to four months tentatively. Accordingly, FOTE redundancy may also be planned. Mizoram told that it is not confirmed whether AGC shall be implemented or not at Doyang HEP. GRID-India stated that these stations are approved as per CERC order; however, they will re-check and confirm during discussion of agenda in NETeST meeting. POWERGRID shared the equipment requirement for redundancy as follows via email dated-04/08/23 as below:

Kopili – No

Khandong -No

Kopili stage 2 -No (In the said meeting, it is informed that Kopili stage 2 and Khandong are in same premises. Therefore, Kopili stage 2 is considered as Khandong).

Kathalguri – No (At present only 1 SDH is PRESENT. However, 1 no. is upcoming under Kathalguri – Namsai (NERXV))

Doyang – Yes

Accordingly one FOTE for Doyang-HEP is required for AGC operation .The agenda shall be put up in RPC TeST for review.

7.0 OPGW Connectivity of 220 kV Zahdima (Nagaland/State node) to 400/220 kV New Kohima (KMTL/ISTS node) (by NERLDC)

DoP Nagaland is constructing 220/132 kV Zahdima substation which will be connected with 400/220 kV (KMTL/ISTS node) over 220 kV Transmission line being constructed by State. It has come to notice that OPGW is not envisaged in the Transmission line.

Forum may discuss about the possibility of considering the OPGW over the 220 KV Zahdima – New Kohima transmission line.

Members may deliberate.

Deliberations: POWERGRID informed that 220KV Zahdima- New Kohima transmission line is a state-sector line and for laying OPGW on this line, ISTS approval of NCT is required. CTU clarified that for laying OPGW on state-sector lines under ISTS, it should be utilized for ISTS communication. Further for the same, agreement of owner state and all other stakeholders is required. The agenda shall be further discussed in NERPC meeting in presence of DoP-Nagaland and other states.

Meeting ended with a vote of thanks from CTUIL.

--xx--

Minutes of 26th NETeST Meeting held on 10th October, 2023

This agenda was deliberated in 25th NETeST meeting held on 25.05.2023 wherein the forum advised CTUIL to inform the critical node identified by PGCIL/CTU to the forum.

CTU has identified few SPOF nodes such as Bongaigaon, Melriat, Imphal and Dimapur. POWERGRID may confirm status of redundant FOTE and Power Supply at these nodes.

Further, any other SPOF nodes may be suggested by members.

Deliberation of the sub-Committee:

POWERGRID informed that 1 no. FOTE & 1 no. Power Supply is available at Bongaigaon, Melriat, Imphal and Dimapur. However redundant FOTE and Power Supply at Melriat & Imphal may not be useful as the exiting network utilization is around 10% and 20% respectively. After detailed deliberation, the forum opined that due to space/cost, FOTE level redundancy is not recommended. The forum requested CTU to identify to alternate links/route to these SPOF.

The Sub-Committee noted as above.

Action: CTU

A.21 Additional FOTE at AGC locations

Additional FOTE at all AGC operated generating stations in North Eastern region is required in view of resource disjoint and criticality of AGC operation for grid operation purpose as failure of single equipment may lead to disruption in AGC operation. Further, at many locations redundant ethernet port are not available as per NLDC requirement. The NLDC requirement is as follows:

- 1+1 Ethernet port for main NLDC
- 1+1 Ethernet ports are for backup NLDC

This is to be deliberated for additional FOTE and ports/cards at AGC locations.

Following AGC Locations may be considered for additional FOTE:

- a) Kopili – AGC under implementation
- b) Khandong – AGC under implementation
- c) Kopili Stage 2 – AGC under implementation
- d) Kathalguri – AGC under implementation
- e) Doyang HEP – AGC under implementation

Deliberations in 4th CPM: GRID-INDIA informed the forum that five nos. of new AGC stations as stated above are planned for implementing the AGC in NE Region as per CERC order and these stations shall be operational for AGC in next three to four months tentatively. Accordingly, FOTE redundancy may also be planned.

POWERGRID shared the FOTE equipment requirement for redundancy as follows via email dated-04/08/23 as below:

- **Kopili** – No
- **Khandong** -No
- **Kopili stage 2** -No (In the said meeting, it is informed that Kopili stage 2 and Khandong are in same premises. Therefore, Kopili stage 2 is considered as Khandong).
- **Kathalguri** – No (At present only 1 SDH is PRESENT. However, 1 no. is upcoming under Kathalguri – Namsai (NERXV)
- **Doyang** – Yes

Accordingly, one FOTE for Doyang-HEP is required for AGC operation.

Deliberation of the sub-Committee:

NERLDC informed the forum that as per CERC Ancillary Regulation, 2022 Subhansiri (Upcoming NHPC Plant), Kameng (NEEPCO) and Palatana (OTPC) also qualifies for AGC implementation. Thus, additional FOTE should be considered for Subhanshiri (Upcoming NHPC Plant), Kameng (NEEPCO), Palatana (OTPC) and Doyang-HEP.

The Sub-Committee noted as above.

Action: CTU

A.22 Connectivity of STU node on fibre in view of AMR.

The meter readings from several locations (mostly STU nodes) (list of location shall be provided by Grid-India) in each region are intermittent and having communication issues as the meters at the state nodes are not having secure & reliable communication links and are operational on public domain communication links like GPRS. It is proposed to provide the connectivity of such nodes on captive OPGW network for receiving the data successfully for AMR purpose.

Grid-India has identified a list of such nodes (list attached as **Annexure A.22**) for each region.

The line length (for the STU nodes as listed in **Annexure A.22**) from STU node to nearest ISTS node may be provided by Grid-India/STU/State constituent along with line name, line ownership so as to prepare a scheme for OPGW laying. Based on the inputs received, the scheme shall be made and put up for approval in NCT.

After detailed deliberation the forum recommends PSDF Secretariat to reconsider the sanctioned amount in view of the higher price discovery during procurement.

TCC recommended for approval of RPC.

Deliberation of the RPC

The RPC noted and approved the recommendation of TCC.

ITEM NO. B.11	:	STRENGTHENING OF LAST MILE FIBER-OPTIC CONNECTIVITY TO OBTAIN BETTER RELIABILITY AT NERLDC, SHILLONG AND BACKUP NERLDC, GUWAHATI: - NERLDC
---------------	---	---

NERLDC, Shillong is currently connected to 132 kV NEHU (MeECL) sub-station over fiber-optic media which is more than 15 years old and has crossed its lifespan leading to deterioration of associated optical-fibers. Since the optical-fiber carries important real-time power system operational data and voice; hence, the fiber-optic should be replaced between "NEHU and NERLDC Shillong (partially overhead and partially underground) preferably with a 2x24-fiber redundant arrangement".

Similarly, Backup NERLDC at Kahilipara, Guwahati is connected over OPGW of 132 kV Kahilipara-Sarusajai and 132kV Kahilipara – Umiam Stg. III – Umiam Stg. I – NEHU which is a twelve (12) fiber link and same has exceeded its life-span of 15 years since its installation under ULDC Phase-1 scheme. In order to maintain reliability of communication system at mission-critical establishment of NERLDC as well as regional communication backbone network, it will be beneficial to replace the OPGW on above-mentioned lines with at least twenty-four (24) fibres.

As several OPGW projects in NER are already under tendering/execution stage by POWERGRID; hence, the aforesaid links can be included in such projects (i.e., NER Reliable Communication Scheme or other similar projects or any new project, as per feasibility by POWERGRID) for faster completion.

TCC/NERPC may kindly approve the replacement of three sections namely "NERLDC Shillong – NEHU", "132 kV Kahilipara – Sarusajai" and "132 kV Kahilipara – Umiam Stg. III – Umiam Stg. I – NEHU" under any of the POWERGRID projects (such as NER

Reliable Communication Scheme or other similar projects or any new project, as per feasibility by POWERGRID) being executed by ULDC team of POWERGRID-NERTS.

Deliberation of the TCC

AGM, AEGCL informed that the OPGW links are very old and has reached EOL thus may be replaced ASAP.

Sr.GM, CTUIL informed that as per MoP notification all communication proposal shall need to be approved by NCT. After NCT approval the same shall be accommodated under suitable project. Further, he stated in all Regions it is common practice to check healthiness of fibers every 6 months. So, all links healthiness may be periodically provided to CTU, whereupon unhealthy links can be replaced irrespective of the life of the fiber.

ED, NERLDC stated that procedure needs to be followed, so TCC may recommend for replacement. After detailed deliberation the forum recommended for replacement of OPGW with 24 Fiber and referred the same to NCT (substantiated with test report) after RPC approval.

Director (Trans), MePTCL noted that commercial issues need to be considered and requested for clarity on Revenue Sharing mechanism.

TCC recommended for approval of RPC.

Deliberation of the RPC

The RPC noted and approved the recommendation of TCC.

ITEM NO. B.12 : FIBER CONNECTIVITY FOR CRITICAL CENTRAL-SECTOR TAIL-END GENERATING STATIONS: - NERLDC
--

Some of the generating stations currently connected over single fiber-optic link are as follows –

a) Kameng Hydro Station (600 MW): Currently, fiber-optic connectivity is being done with 400 kV Kameng-Balipara OPGW only. It may be noted that OPGW works of 132 kV Kameng-Khupi are already under progress; hence, in order to establish physical redundancy for establishing secondary communication channel of Kameng, an OPGW should be laid over 132 kV Khupi – Tenga – Balipara section also. Kindly refer to the **Annexure-B.12** for details.

B. Follow up agenda items

B.1:Agenda to be deliberated

1)Replacement of FO link for “NERLDC Shillong – NEHU”, “132 kV Kahilipara – Sarusajai” and “132 kV Kahilipara – Umiam Stg. III – Umiam Stg. I – NEHU”.

POSOCO stated that in the 23rd TCC and NERPC meeting, TCC forum recommended for replacement of OPGW with 24 Fiber for NERLDC Shillong – NEHU”, “132 kV Kahilipara – Sarusajai” and “132 kV Kahilipara – Umiam Stg. III – Umiam Stg. I – NEHU” after RPC and NCT approval. This proposal for replacement shall be substantiated with test report of fiber healthiness. But test report is not available with Meghalaya SLDC as the links have not been handed over to them by POWERGRID. POWERGRID stated that automatic handing over of the link ownership takes place after completion of fifteen years.

Further deliberations were held regarding ownership and maintenance of the said links.

CTUIL stated that since these links are being used for ISTS data & voice communication and this communication shall be kept intact. In view of this CTU requested POWERGRID to clarify the entity who is maintaining the above said lines.

Deliberations in the 4th CPM: POWERGRID told that this link contains critical ISTS data and this is the only path for NERLDC connectivity with only 12 Fibers. POWERGRID shared the connectivity diagram of NERLDC (as shown in figure below) and explained the criticality of these links. POWERGRID told that if Meghalaya is ready to maintain and takeover the link they have no issue in handing over these links.

However, GRID-INDIA informed that one of the above links i.e 132 kV Kahilipara – Sarusajai section belongs to Assam which is not vital for NERLDC connectivity and replacement of OPGW on this link shall be considered separately in consultation with Assam. Further, GRID-INDIA stated that 132kV NEHU-Umiam-I-Umiam -III is critical for Grid operation as most of the NERLDC data and AGC data is being routed through this path. In view of this, GRID-INDIA requested CTU for approval for laying of OPGW on these lines to be obtained from NCT. CTU suggested OPGW replacement on all these links may be carried out by single party considering reliability of backbone connectivity to NERLDC. CTU clarified that for approval of OPGW replacement on these lines under ISTS scheme from NCT, the replacement of OPGW shall be substantiated with test report of fiber healthiness which was asked for in the 23rd TCC and NERPC meeting also.

POWERGRID also intimated that Meghalaya is also implementing OPGW on Khleiriat-NEHU section which provides path redundancy for NERLDC. CTU suggested POWERGRID to check whether 48 Fibers can be laid on the “NERLDC Shillong – NEHU” and “132 kV Kahilipara – Umiam Stg. III – Umiam Stg. I – NEHU” paths so that fibers can be shared for ISTS and STU

purposes. CTU requested POWERGRID to provide test-report of fiber healthiness of these links so that further review/approval in NETeST/TCC/NERPC & subsequently NCT may be taken up.

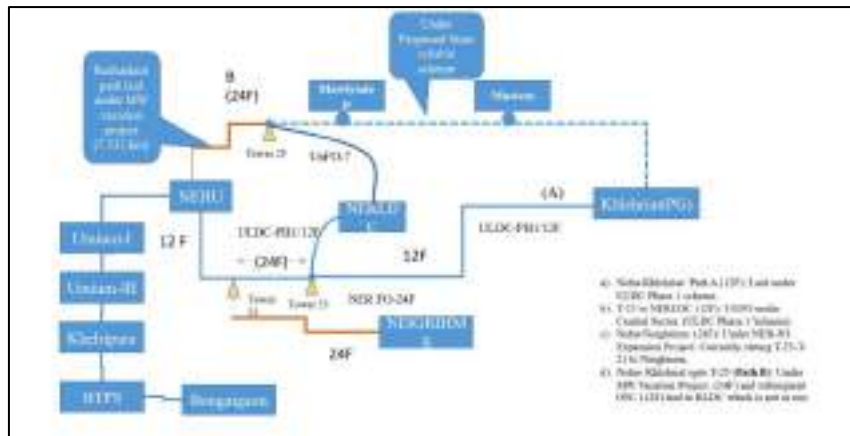

Connectivity diagram of NERLDC

Deliberations in 26th NETeST meeting: MePTCL informed the forum that they desire to BOO (Build – Own – Operate) the OPGW in their Transmission lines. POWERGRID – ULDC informed the forum that NEHU – Khlehiat link has been laid in ULDC Phase 1. They are also laying a 12F link from T23 of Nehu – Khlehiat to NERLDC. POWERGRID – ULDC also informed that under MW vacation project, a 7.532KM 24F NEHU – T25 link was laid; whereas T25- Mawlyndep – Mustem – Khlehiat link was to done under State reliable scheme. However, as MePTCL has desired to BOO these links, POWERGRID is ready to handover these link to MePTCL on a mutually agreeable date provided maintenance of these links are also undertaken by MePTCL. POWERGRID also informed that due to system constraint, if required, the 7.532KM NEHU – T25 link can be decapped subject to TCC/RPC approval. CTU also informed the forum that the ownership and maintenance accountability of these links has to be established before such proposed transfer. The forum noted as these are policy matters which warrants further detailed deliberation, the forum decided to conduct a separate meeting for the same.

Members may deliberate.

Deliberation:

It was suggested in the forum that 48 fibers may be laid and maintained by POWERGRID on Meghalaya owned lines i.e “NERLDC Shillong – NEHU”, “132 kV Kahilipara – Umiam Stg. III – Umiam Stg. I – NEHU” . Out of 48 fibers, 24 fibers will be for ISTS use and rest 24 fibers for state purpose.

This was agreed in the forum. However, Meghalaya stated that they will have to take consent from their management for the said proposal.

CTU also requested POWERGRID to provide OTDR report for the running link so that the proposal for replacement may be substantiated.

B.2: Status updation agenda

1) Providing redundant path to radial nodes in North Eastern Region

As per the CEA communication planning manual clause 4.1.2, the radial ISTS nodes are required to be connected on redundant paths. In this regard, CTUIL has prepared the list of nodes/stations/generating stations, which are on radial fibre connectivity or on single communication path (PLCC/Leased line etc) as under:

S. No.	Station Name	Paths
i)	Kameng(NEEPCO)	PLCC link
ii)	Ziro(PG)	Single fiber path

i) Kameng (400kV NEEPCO)

Fiber path connecting Kameng to Balipara is under implementation. Presently, Kameng is communicating with Balipara through PLCC.

For second path connectivity of Kameng, agenda was deliberated in 2nd meeting of NER ISTS communication system planning.

The agenda was further discussed in 23rd TCC and 23rd NERPC meeting held on 18th and 19th November 2022. After detailed deliberations, TCC forum recommended POWERGRID to install fiber for 132kV Balipara-Nechipu-Dokumpani-Dikshi- Khupi-Kameng (under implementation in comprehensive scheme by POWERGRID) at the earliest. The RPC approved the recommendation of TCC.

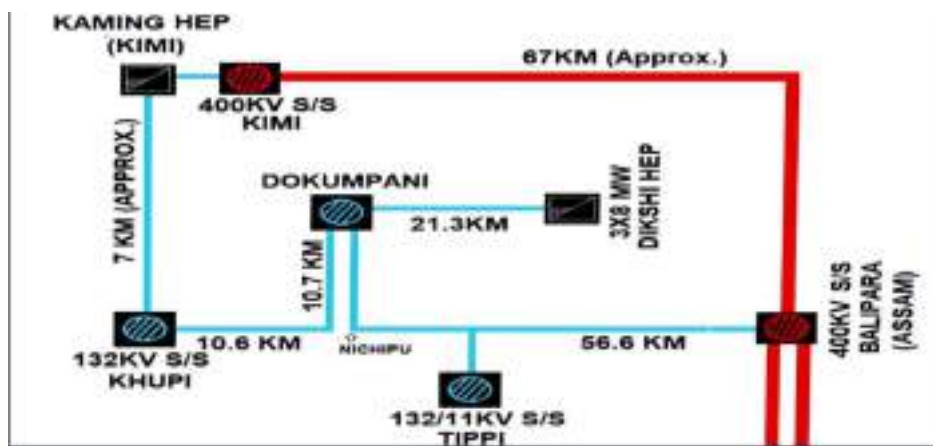

Connectivity of Kameng

Deliberations in 4th CPM: For the direct link between Kameng and Balipara, POWERGRID informed that OPGW stringing is completed and equipment installation and commissioning is pending due to unavailability of DCPS which needs to be provided. POWERGRID told that the link shall be commissioned by **15th August 23.**

Minutes of Special Review Meeting held on 7th March, 2024
links to NERLDC, Shillong via 400 kV Silchar- Byrnihat Line and 220 kV New Shillong S/s.

(b) 132 kV NEHU – Khliehriat CKT-II

NERLDC informed the forum that 12F OPGW between NEHU to Khliehriat was laid in ULDC Phase-1 and it has completed its useful life of 15 years. As such replacement of the same has become essential. After detailed deliberation, the forum agreed to the following:

1. **48F OPGW from NEHU to Khliehriat:** The Forum suggested that the OPGW should be upgraded to 48F by POWERGRID in consultation with CTU.
2. **From T-23 to NERLDC:** 12F Underground cable will be upgraded to 24F cable which is already part of the Reliable communication scheme.
3. **From T-23 to NEIGRIHMS:** 24F OPGW is already laid under the NER FO scheme which will be connected to NEHU and Khliehriat.
4. The proposed distribution of the fiber shall be as follows:

SN	From	To	Number of Fiber
1	NEHU	Khliehriat	24F
2	NEHU	NERLDC	12F
3	NERLDC	Khliehriat	12F
4	NEHU	NEIGRHIMS	12F
5	NEIGRHIMS	Khliehriat	12F

5. CEA has constituted a committee under the chairmanship of Member (Power System), CEA for formulating comprehensive guidelines for the usage and sharing of optical fibers (OPGW) for power system applications. NER will follow the guidelines approved by the committee.

The forum noted as above.

Action: POWERTEL, MePTCL, POWERGRID-ULDC, CTUIL, NERLDC & NERPC.

A.2 Replacement of FO link for “NERLDC Shillong – NEHU”, “132 kV Kahilipara – Sarusajai” and “132 kV Kahilipara – Umiam Stg. III – Umiam Stg. I – NEHU”.

Grid-India stated that in the 23rd TCC and NERPC meeting, TCC forum recommended for replacement of OPGW with 24 Fiber for NERLDC Shillong – NEHU”, “132 kV Kahilipara – Sarusajai” and “132 kV Kahilipara – Umiam Stg. III – Umiam Stg. I – NEHU” after RPC and NCT approval. This proposal for replacement shall be substantiated with test report of fiber healthiness. But test report is not available with

Meghalaya SLDC as the links have not been handed over to them by POWERGRID. POWERGRID stated that automatic handing over of the link ownership takes place after completion of fifteen years.

Further deliberations were held regarding ownership and maintenance of the said links. CTUIL stated that since these links are being used for ISTS data & voice communication and this communication shall be kept intact. In view of this CTU requested POWERGRID to clarify the entity who is maintaining the above said lines.

Deliberations in 4th CPM: POWERGRID told that this link contains critical ISTS data and this is the only path for NERLDC connectivity with only 12 Fibers. POWERGRID shared the connectivity diagram of NERLDC (as shown in figure below) and explained the criticality of these links. POWERGRID told that if Meghalaya is ready to maintain and takeover the link they have no issue in handing over these links.

However, GRID-INDIA informed that one of the above links i.e 132 kV Kahilipara – Sarusajai section belongs to Assam which is not vital for NERLDC connectivity and replacement of OPGW on this link shall be considered separately in consultation with Assam. Further, GRID-INDIA stated that 132kV NEHU-Umiam-I-Umiam -III is critical for Grid operation as most of the NERLDC data and AGC data is being routed through this path. In view of this, GRID-INDIA requested CTU for approval for laying of OPGW on these lines to be obtained from NCT. CTU suggested OPGW replacement on all these links may be carried out by single party considering reliability of backbone connectivity to NERLDC. CTU clarified that for approval of OPGW replacement on these lines under ISTS scheme from NCT, the replacement of OPGW shall be substantiated with test report of fiber healthiness which was asked for in the 23rd TCC and NERPC meeting also.

POWERGRID also intimated that Meghalaya is also implementing OPGW on Khleiriat-NEHU section which provides path redundancy for NERLDC. CTU suggested POWERGRID to check whether 48 Fibers can be laid on the “NERLDC Shillong – NEHU” and “132 kV Kahilipara – Umiam Stg. III – Umiam Stg. I – NEHU” paths so that fibers can be shared for ISTS and STU purposes. CTU requested POWERGRID to provide test-report of fiber healthiness of these links so that further review/approval in NETeST/TCC/NERPC & subsequently NCT may be taken up.

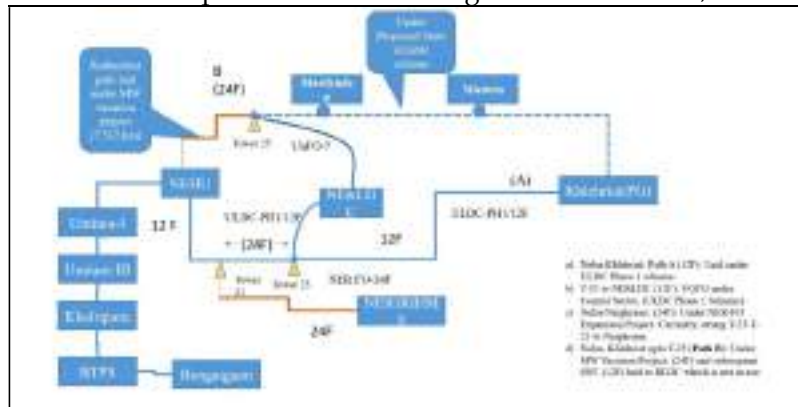

Connectivity diagram of NERLDC

Deliberations in 26th NETeST meeting: MePTCL informed the forum that they desire to BOO (Build – Own – Operate) the OPGW in their Transmission lines. POWERGRID – ULDC informed the forum that NEHU – Khlehriat link has been laid in ULDC Phase 1. They are also laying a 12F link from T23 of Nehu – Khlehriat to NERLDC. POWERGRID – ULDC also informed that under MW vacation project, a 7.532KM 24F NEHU – T25 link was laid; whereas T25- Mawlyndep – Mustem – Khlehriat link was to done under State reliable scheme. However, as MePTCL has desired to BOO these links, POWERGRID is ready to handover these link to MePTCL on a mutually agreeable date provided maintenance of these links are also undertaken by MePTCL. POWERGRID also informed that due to system constraint, if required, the 7.532KM NEHU – T25 link can be decapped subject to TCC/RPC approval. CTU also informed the forum that the ownership and maintenance accountability of these links has to be established before such proposed transfer.

In 27th NETeST meeting, it was decided that separate meeting shall be conducted.

Deliberation of the forum:

- (a) **Replacement of FO link for “NERLDC Shillong – NEHU”** - discussed in Agenda A.1.
- (b) **Replacement of FO link for “132 kV Kahilipara – Sarusajai”** – The forum noted that as this AEGCL’s section is not vital for NERLDC connectivity so replacement and maintenance of OPGW on this section shall be considered by State/STU.
- (c) **Replacement of FO link for “132 kV Kahilipara – Umiam Stg. III – Umiam Stg. I – NEHU”** – CTUIL via email informed that as per the discussion held in 5th CPM meeting of CTUIL, it was suggested in the forum that 48 fibers may be laid and maintained by POWERGRID on Meghalaya owned lines “132 kV Kahilipara – Umiam Stg. III – Umiam Stg. I – NEHU”. Out of 48 fibers, 24 fibers

Minutes of Special Review Meeting held on 7th March, 2024
will be for ISTS use and the rest 24 fibers for state purpose. This was agreed in the forum. However, Meghalaya stated that they will have to take consent from their management for the said proposal.

Meghalaya (MePTCL) informed that their management has approved the laying and maintenance of 48 fibers by POWERGRID in “132 kV Kahilipara – Umiam Stg. III – Umiam Stg. I – NEHU” subject to the use of 24 fibers for ULDC/System requirement and balance for their own commercial purpose. However, POWERGRID opined that the usage and sharing of the fibers is to be done as per CEA/CERC guidelines/regulations.

Additionally, MePTCL has made a request to connect the 132 kV Kahilipara – Umiam Stage III line at 132 kV Umtru for improved connectivity. The forum agreed to the same and endorsed the establishment of the link as 132 kV Kahilipara – Umtru - Umiam Stg. III – Umiam Stg. I – NEHU. Further discussions regarding the distribution of OPGW between ULDC-POWERGRID and MePTCL to take place in subsequent meetings.

AEGCL highlighted the critical nature of the 132 kV Kahilipara – Umtru OPGW link for Assam, NERLDC, and Meghalaya. AEGCL requested that the OPGW over the 132 kV Sarusajai – Umtru line to be considered as a redundant path. The forum has acknowledged the same and decided to deliberate on it in forthcoming meetings.

The forum noted as above.

Action: MePTCL, AEGCL, POWERGRID-ULDC, CTUIL, NERLDC & NERPC.

Any other item:

A.3 Connectivity of NERLDC Guwahati with Sarusajai and Umiam bypassing Kahilipara for its redundancy.

During a meeting held on August 8th, 2022, involving Communication-AEGCL, SLDC Assam, NERLDC Grid-India, and ULDC-POWERGRID, several decisions were made. It was agreed that POWERGRID would lay two 24-core fiber optic cables from NERLDC Guwahati to Gantary of Kahilipara. At Gantary, a Joint Box would be installed, facilitating the connection of one cable from NERLDC to the Sarusajai direction and the other cable to the Umtru direction.

MoM for virtual meeting held on 02.11.2023 for Dual reporting of RTU, PMU, VOIP, AGC etc. applications on 2+2 channel to main RLDC and Backup RLDC for North Eastern Region

Meeting started with opening remarks from Sr. DGM (CTUIL). He welcomed the participants in the meeting and made them aware about the growing communication requirements for ISTS as renewable energy is being injected into the grid at a very fast pace.

List of participants is attached at **Annexure-I**.

The agenda was discussed in 4th CPM dated 28.07.2023 and in the 26th NETeST meeting for North Eastern region specifically. POWERGRID has provided the requirement of FOTE, Ethernet cards, SAS, cards in SAS as per enclosed list in **Annexure-II**.

Deliberations:

POWERGRID provided following inputs:

1)POWERGRID provided the data for requirement of ports in SAS/RTU as per enclosed **Annexure-III**. However, POWERGRID shall clarify whether new SAS or new ethernet card is required in existing SAS after discussion with their AM department. POWERGRID to provide the cost estimate for required ethernet card/ SAS also.

2)Cost of one ethernet card for FOTE was stated by POWERGRID as 1.25 lacs approx.

3)CTU stated that as per the data provided by POWERGRID, one no. of SDH each at Ziro, Loktak and NTPC BgTPP is required. However, additional SDH for Loktak and NTPC BgTPP have already been considered in 'Additional FOTE for AGC scheme' and the requirement for dual redundancy at these two locations shall be met with these FOTES at these locations. CTU further stated that for requirement of additional ethernet card at NTPC BgTPP, POWERGRID may include this requirement in the additional SDH requirement at NTPC BgTPP in the 'Additional FOTE for AGC scheme'. POWERGRID agreed with the same.

4)Requirement of one no. of SDH with minimum 8 no. of ethernet ports was agreed in the meeting for Ziro S/s.

Meeting ended with a vote of thanks from CTUIL.

Annexure-I

The list of participants is listed below:

Sr. No.	Name	Company Name	Designation
1	Shri H.S Kaushal	CTUIL	Sr.GM
2	Shri S.K Gupta	CTUIL	Sr.DGM
3	Shri Kaushal Suman	CTUIL	Mgr
4	Shri Vishal Badlas	POWERGRID	Mgr

Availability of additional requirement of RTU/SAS ethernet port at substation for dual redundancy of channels at Main and Back up RLDC				
Region	Name of Substation	Data reporting RLDC through RTU/SAS GW	RTU/SAS	
			Are 5 no. of ethernet port available in existing RTU/SAS?(YES/NO)	If no, please mention requirement of RTU/SAS/Ethernet card.
NER	Kumarghat S/S	SAS GW	No	01 no. of spare port required in 2 gateways each as from each gateway 01 port is already reporting to RLDC. Data reporting to RLDC, RTAMC, BNTAMC, NTAMC from each gateway.
NER	Jiribam	SAS GW	No	01 no. of spare port required in 2 gateways each as from each gateway 01 port is already reporting to RLDC. Data reporting to RLDC, RTAMC, BNTAMC, NTAMC from each gateway.
NER	Haflong	SAS GW	No	01 no. of spare port required in 2 gateways each as from each gateway 01 port is already reporting to RLDC. Data reporting to RLDC, RTAMC, BNTAMC, NTAMC from each gateway.
NER	Dimapur	SAS GW	No	01 no. of spare port required in 2 gateways each as from each gateway 01 port is already reporting to RLDC. Data reporting to RLDC, RTAMC, BNTAMC, NTAMC from each gateway.
NER	Aizawl	SAS GW	No	01 no. of spare port required in 2 gateways each as from each gateway 01 port is already reporting to RLDC. Data reporting to RLDC, RTAMC, BNTAMC, NTAMC from each gateway.
NER	Roing	SAS GW	No	01 no. of spare port required in 2 gateways each as from each gateway 01 port is already reporting to RLDC. Data reporting to RLDC, RTAMC, BNTAMC, NTAMC from each gateway.
NER	Tezu	SAS GW	No	01 no. of spare port required in 2 gateways each as from each gateway 01 port is already reporting to RLDC. Data reporting to RLDC, RTAMC, BNTAMC, NTAMC from each gateway.
NER	Namsai	SAS GW	No	01 no. of spare port required in 2 gateways each as from each gateway 01 port is already reporting to RLDC. Data reporting to RLDC, RTAMC, BNTAMC, NTAMC from each gateway.
NER	Mokokchung	SAS GW	No	Presently station is reporting on IEC-101 from each gateway to RLDC. If reporting is to be made on IEC-104 then, there shall be requirement of 02 Nos Port in each gateway. Details of ports used in each gateway : 104 ports - RTAMC, NTAMC, BNTAMC, spare, 101 port - RLDC
NER	Melriat	SAS GW	No	01 no. of spare port required in 2 gateways each as from each gateway 01 port is already reporting to RLDC
NER	Balipara	RTU	No	Data is reporting to RLDC via 01 no. port (101 protocol) of Main & Standby Gateway each. Details of ports used in each gateway : 104 ports - RTAMC, NTAMC, BNTAMC, spare, 101 port - RLDC Being conventional station, data is also reporting through RTU via 1 port. Another 01 no port shall be required for Back up RLDC.
NER	Misa	RTU	No	Data is reporting to RLDC via 01 no. port (101 protocol) of Main & Standby Gateway each. Details of ports used in each gateway : 104 ports - RTAMC, NTAMC, BNTAMC, spare, 101 port - RLDC Being conventional station, data is also reporting through RTU via 1 port. Another 01 no port shall be required for Back up RLDC.
NER	Bongaigaon	RTU	No	Data is reporting to RLDC via 01 no. port (101 protocol) of Main & Standby Gateway each. Details of ports used in each gateway : 104 ports - RTAMC, NTAMC, BNTAMC, spare, 101 port - RLDC Being conventional station, data is also reporting through RTU via 1 port. Another 01 no port shall be required for Back up RLDC.
NER	BNC	SAS GW	No	01 no. of spare port required in 2 gateways each as from each gateway 01 port is already reporting to RLDC. For BNTAMC 01 no. of spare port required in 2 gateways each as from each gateway 01 port is already reporting to NTAMC.
NER	Badarpur	RTU	No	Data is reporting to RLDC via 01 no. port (101 protocol) of Main & Standby Gateway each. Details of ports used in each gateway : 104 ports - RTAMC, NTAMC, BNTAMC, spare, 101 port - RLDC Being conventional station, data is also reporting through RTU via 1 port. Another 01 no port shall be required for Back up RLDC.
NER	Khelrihat	RTU	No	Being conventional station, data is reporting through RTU via 1 port. Another 01 no port shall be required for Back up RLDC
NER	Silchar	SAS GW	No	Presently station is reporting on IEC-101 from each gateway to RLDC. If reporting is to be made on IEC-104 then, there shall be requirement of 02 Nos Port in each gateway. Details of ports used in each gateway : 104 ports - RTAMC, NTAMC, BNTAMC, spare, 101 port - RLDC
NER	Mariani	SAS GW	No	01 no. of spare port required in 2 gateways each as from each gateway 01 port is already reporting to RLDC. Details of ports used in each gateway : 104 ports - RTAMC, NTAMC, BNTAMC, spare, 101 port - RLDC
NER	Nirjuli	SAS GW	Yes	
NER	Ziro	RTU	No	Being conventional station, data is reporting through RTU via 1 port. Another 01 no port shall be required for Back up RLDC
NER	Salakati	SAS GW	Yes	Existing 02 nos. of D400 gateway has 01 spare port each. From both D400 gateways, 01 port is reporting to RLDC.
NER	Imphal	SAS GW	No	01 no. of spare port required in 2 gateways each as from each gateway 01 port is already reporting to RLDC. Details of ports used in each gateway : 104 ports - RTAMC, NTAMC, BNTAMC, spare, 101 port - RLDC .

* Additionally required ethernet port over and above existing capacity.

Note - For additional port reporting to Back up RLDC, necessary configuration in SAS shall be required

	YES	NO
SAS	2	14
RTU	0	6

Availability details of RTU/SAS ethernet port at various POWERGRID stations for data reporting to Main and Back up RLDC through redundant channels

Sl.No	Region	Total Stations	No of stations				Remarks
			SAS(Are 5 no. of ethernet ports available)		RTU(Are 5 no. of ethernet ports available)		
			Yes(No's)	No(No's)	Yes(No's)	No(No's)	
1	WR1	26	15	9	2	0	
2	WR2	32	9	18	4	1	
3	SR1	21	0	13	0	8	
4	SR2	38	0	25	0	13	
5	ER1	17	11	1	0	5	Upgradation WIP SAS_5, RTU_5
6	ER2	14	4	3	1	6	Upgradation WIP SAS_5, RTU_6
7	NR1	38	8	22	4	4	
8	NR2	25	1	18	5	1	
9	NR3	27	5	15	5	2	
10	NER	22	2	14	0	6	
11	ODISHA	10	5	0	0	5	Upgradation WIP SA_1, RTU_5
Total		270	60	138	21	51	
Final qty (Stations are Excluded which are under upgradation)				138		35	
						Rate per station(Cr.)	Amount in Crores
Total SAS based stations				138		1.5	207.00
Total RTU based stations					35	0.3	10.50
Grand Total							217.50



ANNEXURE II

Site Name	Total Licence (IP Phone)	IP Phone-configured in System	No of used IP Phone	Total Licence (SIP Phone)	SIP Phone-configured in system	No of used SIP Phone	Total Licence (2 Wire/Analog phone)	No of used Analog Phone	Analog Phone configured in system
Imphal	142	20	5	40	0	0	84	information to be provided by respective STU	96
SLDC,Nehu	142	25	20	40	5	5	84		96
Guwahati	142	56	25	40	0	0	148		96
Aizwal	142	11	4	40	0	0	84		34
Diamapur	142	26	4	40	0	0	84		70
Agartala	142	44	8	40	0	0	116		96
Itanagar	142	25	4	40	0	0	84		70
	994	207	70	280	5	5	684		0

CYBER SECURITY MEASURES IMPLEMENTATION STATUS FOR NER SLDCs (AS ON 13.05.2024)

SN	Cyber Security Measures	Arunachal Pradesh	Assam	Manipur	Meghalaya	Mizoram	Nagaland	Tripura
1	Preparation and approval of Cyber Crisis Management Plan (CCMP) for SLDCs	Final CCMP approved by CERT-In. Rev-1 to be issued after incorporation of the comments from CERT-GO.	Final CCMP approved by CERT-In. 3rd Revised version of CCMP issued on 14-09-22 and approved by CERT-In.	Final CCMP approved by CERT-In.	Final CCMP approved by CERT-In. Revision 1 in progress	Final CCMP approved by CERT-In. Revision under process.	Final CCMP approved by CERT-In.	Final CCMP approved by CERT-In.
2	Implementation status of Information Security Management System (ISMS) i.e., ISO 27001 and certification audit for ISO-27001	Implemented. Arunachal SLDC received certification for ISMS (ISO 27001:2013) on 19.09.2023. Rev1 dtd. 06.10.2023. Expiry of certificate 31.10.2025.	Implemented. Assam SLDC has received certification for ISMS (ISO 27001: 2013) on 09.07.22. 1st Surveillance Audit has been carried out in 4th July'23. Report received and Certificate of First Surveillance Audit received on 08.07.2023.	LOA issued to CDAC, Hyderabad on 3rd Nov'21 for Implementation of ISMS (ISO-27001). Implementation could not be completed as CDAC Hyderabad team could not visit the Manipur. Work has been extended till 31-12-2024.	Implemented. Meghalaya SLDC has received certification for ISMS (ISO 27001: 2013) on 08.07.22. 1st Surveillance Audit has been carried out in June'23 and certificate received.. Certification validity extended up to 8.07.2024.	ISO 27001 being executed. VAPT completed and mitigation to be done. ISMS stage-1 audit done. Stage-2 audit pending to get certification.	Implemented. Nagaland SLDC has received certification for ISMS (ISO 27001: 2013) on 01.06.23.	Contract has been awarded to Certifying Agency and implementation is in final stage.
3	Status of VA-PT on OT systems	Done for FY 22-23.	Done for FY 22-23.	Done for FY 23-24.	Done for FY 22-23. and for FY 2023-24 conducted on 18th to 23rd March 2024.	Done for the year 2024	Done for FY 23 - 24	Done for FY 23-24.
	i) Date of Last VA-PT (OT):	24/03/2023- 28/03/2023	17/02/2023 - 21/02/2023	21/01/2024-24/01/2024	18/03/2024 to 23/03/2024	Jan-24	10/01/2024-13/01/2024	29/01/2024- 01/02/2024.
	Submission of latest VA-PT report carried out on OT systems of SLDC for onward submission to MoP		Revised Report Received. shared with MoP	Reports received and fixed the vulnerabilities. Awaiting final report.	Reports received and will be submitted to MoP	Report not received yet	Reports received and submitted to MoP	Report for FY 24-25 submitted by GE in 22nd April 2024.
	ii) Due date for Next Audit / Plan for next audit (OT) :	01-02-2024	17-02-2024 scheduled to being on 13.05.2024	July-August-2024	See (i) above	01-01-2025	Next year(2025)	-
4	Status of VA-PT on IT systems (to be done once in every six months)	No IT infrastructure is present in the SLDC. Shall be carried out after implementation of SAMAST and the related IT infrastructure.	Last VAPT completed on 07.02.2024; reports received.	Phase -1 of VAPT for IT systems has been completed. Phase-2 was scheduled in June'23; which is still pending due to prevailing situation of unrest in Manipur. It will be done soon.	Last VAPT completed in March-2024 Reports received and mitigation is being carried out.	VAPT done on March 2024, mitigation to be done.	VAPT on IT systems done from 24 Aug 2023 to 28 Aug 2023.	Last VAPT of IT system completed in March-2023. Reports recieved from CDAC.
5	Notification of identified systems at SLDCs as Critical Information Infrastructure (CII)	Final revised CII document has been submitted to NCIIPC after incorporation of comments on 19.05.2023. NCIIPC requested for re-apply along with transmission and distribution utility. SLDC Arunachal requested NCIIPC to declare SLDC Arunachal as CII in initial step.	Identified Systems of SLDC, Assam had been declared as CII by NCIIPC on 10.06.2022. Notification of CII as Protected Systems has been issued by State Govt. on 11.08.2023.	As instructed by NCIIPC new assessment document was prepared merging the transmission utility (MSPCL) and SLDC Manipur. As per latest communication from NCIIPC, the document was thoroughly reviewed by NCIIPC eastern zone and forwarded to NCIIPC headquarters. Awaiting further instructions from NCIIPC	Identified Systems of SLDC, Meghalaya had been declared as CII by NCIIPC on 31.12.2021. Notification of CII as Protected Systems has been issued by State Govt. on 18.04.2022.	Final revised CII document had been submitted. Forwarded by East Zone and presently under approval at NCIIPC head office in New Delhi.	Identified Systems of SLDC, Nagaland had been declared as CII by NCIIPC on 31.12.21. Notification of CII as Protected Systems still pending with the State Govt.	The CII is yet to be approved by NCIIPC. Submitted on 30.09.2023 through email to coord.east@nciipc.gov.in NCIIPC has reviewed the document and given some assignment for addition/alteration in this document. However this assignment is yet to be re-submitted to NCIIPC from SLDC Tripura.
6	Date of last Risk Assessment by NCIIPC (once in every 2 years):	Not done	Not done	Not done	Not done	Not done	Not done	Not done
7	Compliance of advisories from CERT-In, NCIIPC & other statutory agencies.	Being complied for OT	Being complied	Being complied	Being complied	Being complied	Being complied	Being complied
i	To be updated in Portal for monthly compliance by 10th of every month.	Not updated in the portal	Being Updated in Portal	Being Updated in Portal	Being Updated in Portal	Being Updated in Portal	Being Updated in Portal	Being Updated in Portal

CYBER SECURITY MEASURES IMPLEMENTATION STATUS FOR NER SLDCs (AS ON 13.05.2024)

SN	Cyber Security Measures	Arunachal Pradesh	Assam	Manipur	Meghalaya	Mizoram	Nagaland	Tripura
ii	For CERT-In weekly advisories to be complied within 5 days: To be uploaded in the portal after completion.	Being Updated in Portal	Being Updated in Portal	Being Updated in Portal	Being Updated in Portal	Being Updated in Portal	Being Updated in Portal	Being Updated in Portal
ii	Compliance of advisories from Cyber Swachhta Kendra (CSK)	Being Resolved. No new alerts.	Being Resolved. No new alerts.	Being Resolved. No new alerts.	Being Resolved. No new alerts.	Being Resolved. No new alerts.	Being Resolved. No new alerts.	Being Resolved. No new alerts.
8	Compliance of Recommendations of CERT-GO as per SLDC Maturity Model assessment:							
9	Status of Nomination of CISO:	Done	Done	Done	Done	Done	Done	Done
	Alternate CISO (if any):	Nomination of new Alt. CISO is in progress.	Yes	Yes	Yes	Yes	Yes	Yes
10	Cyber Security Certification: (Training attended)	No	Yes. Basic level training and certification on Cyber Security for Power Sector Professionals completed by 7 officers.	Yes. (2 Officials)	Yes. (11 officials undergone Basic level certification course from NPTI and 2 had undergone Intermediate level training in March 2024)	Yes (9 Official trained in Two Weeks Basic Level Training and Certification Program on Cyber Security)	1 Official trained for Basic Level Certification Course(NPTI) in Sep 2023.	Yes. 1 Official (Attended by Alternate CISO)
11	IT - OT Integration:	Not present	Present between SAMAST and SCADA	Present Between SAMAST and SCADA	Present between SAMAST and SCADA. As discussed with NCIIPC during ISSC meeting, the same will be discontinued.	SCADA & SAMAST integration done	Under process for integration between SAMAST and SCADA.	-
12	SOC Implementation status:		Under discussion with vendors for obtaining proposal for preparation of DPR.	DPR preparation phase	Under discussion with Management. (However, main concerns are regarding AMC funding and manpower.)	Under cosideration	Discussed with the Head Management and may agree on the condition 100% AMC is funded.	-

Meeting among Assam-SLDC, AEGCL, NERLDC and POWERGRID-NERTS for site-survey related to planning of Optical-fiber connectivity for NERLDC/Assam-SLDC held at SLDC conference room on 08th August 2022, 1130 Hrs.

A meeting was held among representatives from Assam-SLDC, NERLDC, AEGCL and POWERGRID-NERTS related to planning of fiber-optic connectivity to ensure reliability and redundancy of communication links at NERLDC (new premises) and Assam-SLDC at Kahilipara, Guwahati. The list of participants is listed below.

Arup Kalita (Dy. GM, AEGCL)	S.P. Barnwal (Sr. GM, NERLDC)
Ashutosh Bhattacharjee (Dy. GM, Assam-SLDC)	Akhil Singhal (Ch. Manager, NERLDC)
Pranab Saha (Asst. GM, Assam-SLDC)	Sakal Deep (Asst. Manager, NERLDC)
Ashwini Gogoi (Asst. GM-Kahilipara, AEGCL)	Ashutosh Kumar (Asst. Manager, NERLDC)
Arup Sarma (Asst. GM-Communication, AEGCL)	Kamlesh Baishya (Asst. Manager, POWERGRID)
Rupjyoti Das (Dy. Manager, Assam-SLDC)	P. Johny Singh (Jr. Engineer, POWERGRID)

The meeting started with an outset discussion that planning for adequate reliability and redundancy is of utmost importance for the real-time data telemetry purposes of NERLDC/Assam-SLDC considering its mission critical operations of national importance in power sector. The summary of discussion is mentioned below.

1.0 Directions of communication in optical network

It was deliberated that two directions are necessary for optical fiber communication purposes so as to ensure that any disruption in one direction does not hamper the data-availability at NERLDC/Assam-SLDC. AEGCL & NERTS suggested that two (02) joint boxes are available at Kahilipara sub-station through which one route towards Umiam and other route towards Sarusajai can serve the purpose with one (01) fiber-pair in each route.

Moreover, the SLDC is connected to Rangia and BTPS stations on which bandwidth can be used to provide 10Mbps or more (as required) dedicated links over Ethernet which can be used under any emergency measure by enabling it through associated NMS systems.

2.0 New optical-fibers required for strengthening connectivity of NERLDC, Guwahati and Assam-SLDC

It was discussed that new fibers needs to be laid at few locations as listed in table below.

Sl. No.	Description	Existing/New	Estimated length/ Qty.	No. of cores required	Remarks
1	NERLDC to Assam SLDC (Back-side of Assam-SLDC to back-side of NERLDC)	New fiber to be laid underground	To be depicted as per site-survey	24	NERLDC: Fibcom (existing) & Tejas (SDH under procurement through reliable scheme)

Sakal Deep
Arup Kalita

P. Johny Singh
(P. J. SINGH)

Page 1 of 3
Kamlesh Baishya
(KAMLESH BAISHYA)

Sl. No.	Description	Existing/New	Estimated length/ Qty.	No. of cores required	Remarks
					Assam-SLDC: Keymile, ECI & Fibcom
2	Kahilipara (Gantry) to NERLDC (Separate route from Gantry of Kahilipara to NERLDC Communication Room)	New fiber to be laid underground	To be depicted as per site-survey	24 x 2	NERLDC: FODB Kahilipara: Joint Boxes (One towards to Sarusajai & One towards to Umiam)
3	Kahilipara to Sarusajai (Existing fiber installed in 2003)	12-core OPGW to be upgraded with 24-core OPGW	4 kms. (approx.) which may be included under Qty. variation in reliable communication scheme of POWERGRID after taking approval in upcoming TCC/NERPC Board meeting.	24	Proposal for replacement of OPGW will be placed by AEGCL/NERLDC in TCC/NERPC Board meeting.
4	Kahilipara to Umiam-III to Umiam I-NEHU (Existing fiber installed in 2003)	12-core OPGW to be upgraded with 24-core OPGW	May be included under Qty. variation in reliable communication scheme of POWERGRID after taking approval in upcoming TCC/NERPC Board meeting.	24	Proposal for replacement of OPGW will be placed by PGCIL/NERLDC in TCC/NERPC Board meeting.
5	NERLDC to Rangia (Via Assam-SLDC)	Existing fibers; configuration to be done in NMS.	10Mbps or more dedicated channel to be configured using state network. Inter-patching between FOTEs will be done at	--	NERLDC: Fibcom (existing) & Tejas (SDH under procurement through reliable communication scheme) Assam-SLDC:

Shankar (Sakal Dept) [Signature] [Signature]

[Signature] (P.J.SINGH)

[Signature] (KAMLESH BATHIA)

Sl. No.	Description	Existing/New	Estimated length/ Qty.	No. of cores required	Remarks
			SLDC Assam and Rangia		Keymile, ECI & Fibcom Rangia: Keymile
6	NERLDC to BTPS (Via Assam-SLDC)	Existing fibers; configuration to be done in NMS.	10Mbps dedicated channel to be configured using state network. Inter-patching between FOTEs will be done at SLDC Assam and Rangia		NERLDC: Fibcom (existing) & Tejas (SDH under procurement through reliable communication scheme) Assam-SLDC: Keymile, ECI & Fibcom BTPS: Keymile
7	Additional card procurement and associated commissioning	New cards may need to be procured for various locations	To be listed after site-survey at all associated locations.	--	May be required in Assam-SLDC Rangia & BTPS which needs to be checked.



3.0 Communication to POWERGRID-NERTS related to the OPGW communication and associated end-equipment works

POWERGRID-NERTS requested that a consent from Assam-SLDC/AEGCL may be required for carrying out the necessary OPGW/ Underground Fiber-Optic laying works as per the final route depicted during joint site-survey (refer **Annexure-1** for route) carried out with AEGCL in presence of Assam-SLDC and NERLDC representatives.

Moreover, the necessary written communication for including Kahilipara-Sarusajai OPGW replacement (12-fiber to 24-fiber) under reliable communication scheme may be given to POWERGRID-NERTS and the same may also be taken up as an agenda item for approval in next TCC/NERPC Board meeting by AEGCL/NERLDC.

Meeting ended with noting of the above.

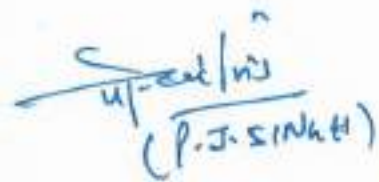
 Sakal Das
 Lakshmi SenGual
 S.P. BARNWAL

 P.J. SINGH
 KARISHMA RASHMI

RE: Intimation of timeline for revival of PLHPS-Itanagar and PLHPS-Pare HPS Ckt-II: Status of OPGW link between PHEP & RHEP regarding.

Narottam Chakraborty <narottam.chakraborty@sterlite.com>

Sun 28-04-2024 21:37

To: Vikash Shankar Singh <vikashiitk308@gmail.com>; Sakal Deep (सकल दीप) <skldeep@grid-india.in>;

Cc: Bhuwanesh Joshi <bhuwanesh.joshi@sterlite.com>; Raushan Kumar <raushan.kumar@sterlite.com>; Kamlesh Baishya (कमलेश Baishya) <kamlesh156@powergrid.in>; nerpc@ymail.com <nerpc@ymail.com>; se.sopsc <se.sopsc@gmail.com>; msdutt@powergrid.in <msdutt@powergrid.in>; Amaresh Mallick (अमरेश मल्लिक) <amareshmallick@grid-india.in>; sundarmoni@neepco.co.in <sundarmoni@neepco.co.in>; santanu@neepco.co.in <santanu@neepco.co.in>; Joy Pal Roy, Manager E. M. ,KHEP NEEPCO,PAID <joypalroy@neepco.co.in>;

1 attachments (179 KB)

OTDR.pdf;

****Warning****

This email has not originated from Grid-India. Do not click on attachment or links unless sender is reliable. Malware/ Viruses can be easily transmitted via email.

Dear Sir

Reference to the trailing mail this is to inform you that as per approved scheme and attached MoM of meeting dated 10.07.2023 we have completed our responsibilities in all respect before commissioning of the North Lakhimpur-Nirjuli-Pare transmission lines on 31.07.23 and 01.08.23 with kind support of all.

Before receipt of this mail reference to the con calls already held with NEEPCO, NERLDC & ULDC we had arranged OPGW splicer and our team checked the continuity of the fibres on 26.04.24 between Pare HEP-Ranganadi HEP. Continuity of all the fibres were found to be available and 6 Nos. were already in use.

On discussion with Mr. Kamallesh Baishya it was confirmed fibre No. 3&4 are only used by ULDC and rest 1,2,11&12 may be used by PGCI (Communication).

We have also ensured connectivity of 2 fibres (7&8) for Diff. Protection of NEEPCO (PHEP-RHEP). The Photo of FODB is attached showing used and unused fibres for reference.



[@skldeep@grid-india.in](mailto:skldeep@grid-india.in) As discussed please confirm the purpose of using fibre Nos. 1,2,11&12 for record as MoM permits use of 4 No. fibres for Power System Purpose, 4 Nos. by NEEPCO & 4 Nos. by MUMML.

Thanking you all for continued support.

--

Regards

Narottam Chakraborty

AVP-Projects, Sterlite Power.

From: Vikash Shankar Singh <vikashiitk308@gmail.com> Dear Sir

Reference to your mail and mail of Mr. Kamlesh Baishya in trailing this is to inform you that as per approved scheme and attached MoM of meeting dated 10.07.2023 we have completed our responsibilities in all respect before commissioning of North Lakhimpur-Nirjuli-Pare transmission lines on 31.07.23 and 01.08.23. The reports had also been submitted to the NERLDC before obtaining FCT of the above elements under MUMML.

Before receipt of this mail reference to the con calls already held with NEEPCO, NERLDC & ULDC we had arranged OPGW splicer and our team checked the continuity of the fibres between Pare HEP-Ranganadi HEP. It is found continuity of the fibres were available and 6 Nos. were already in use. On discussion Mr. Kamallesh Baishya confirmed fibre No. 3&4 are only used by ULDC and rest may be used by PGCI (Communication).

We have also ensured connectivity of 2 fibres for Diff. Protection of NEEPCO. The Photo of FODB is attached showing fibres used and free.

Sent: Friday, April 26, 2024 11:19 AM

To: Narottam Chakraborty <narottam.chakraborty@sterlite.com>

Subject: Fwd: Intimation of timeline for revival of PLHPS-Itanagar and PLHPS-Pare HPS Ckt-II

[EXTERNAL EMAIL] Do not click links or attachments unless you recognize the sender and know the content is safe.

Sir,
W.r.t. the trailing mail, Kindly take necessary action to restore OPGW link between Rangandi and Pare HEP
Regards,
Vikash Shankar, IES(CPES)
AEE/AD-I, NERPC
MoP, Gol

----- Forwarded message -----

From: **Kamlesh Baishya {कमलेश Baishya}** <kamlesh156@powergrid.in>

Date: Thu, Apr 25, 2024 at 6:57 PM

Subject: Re: Intimation of timeline for revival of PLHPS-Itanagar and PLHPS-Pare HPS Ckt-II

To: Vikash Shankar Singh <vikashiitk308@gmail.com>

Cc: neepco edonm <neepco.edonm@gmail.com>, Joy Pal Roy, Manager E M ,KHEP NEEPCO,PAID <joypalroy@neepco.co.in>, Head of Plant Pare HPS <hoppare@neepco.co.in>, saniang@rediffmail.com <saniang@rediffmail.com>, ChaitanyaBh Gorja <gcbharath@neepco.co.in>, Santanu deb <Santanu@neepco.co.in>, Bhaskar Mazumder <bhaskarm@neepco.co.in>, aiegssd@gmail.com <aiegssd@gmail.com>, apslcdc sd <apslcdc.sd@gmail.com>, eesldcitaap@gmail.com <eesldcitaap@gmail.com>, mviswanadh@grid-india.in <mviswanadh@grid-india.in>, pranjalborkataki@grid-india.in <pranjalborkataki@grid-india.in>, vidyutarunachal@gmail.com <vidyutarunachal@gmail.com>, se transmissioncircle <se_transmissioncircle@rediffmail.com>, bimal swargiary <bimal.swargiary@grid-india.in>, se sopsc <se.sopsc@gmail.com>, nerpc@ymail.com <nerpc@ymail.com>, amareshmallick@grid-india.in <amareshmallick@grid-india.in>, biswajit@grid-india.in <biswajit@grid-india.in>, skldeep@grid-india.in <skldeep@grid-india.in>, hop plphs <hop.plphs@neepco.co.in>, exentdii@gmail.com <exentdii@gmail.com>, hodem plphs <hodem.plphs@neepco.co.in>, hop plphs <hop.plphs@neepco.co.in>, Ankit Vaish {अंकित वैश्य} <ankit_vaish@powergrid.in>, Haribabu Rudraraju {रुद्र राजू हरिबाबू} <rudraraju@powergrid.in>, Madhusudan Dutt {एम. दत्त} <msdutt@powergrid.in>, Patham Sridhar {पथम श्रीधर} <psridhar@powergrid.in>, Manash Jyoti Baishya {मानश ज्योति बैश्य} <mjbaishya@powergrid.in>, ftcnerldc@grid-india.in <ftcnerldc@grid-india.in>, Sundar Moni Mohan <sundarmoni@neepco.co.in>

Dear Sir,

As per meeting held on 10.07.2023 between NERPC, POWERGRID, NERLDC, NEEPCO, MUML (MOM attached), regarding reconfiguration of OPGW due to commissioning of Pare-N.Lakhimpur-Nirjuli line, the existing OPGW configuration was modified and the modifications were carried out by MUML as follows:

- 1.
2. 1. 24 Fibre between North Lakhimpur and Pare.
- 3.
4. 2.24 Fibre between North Lakhimpur and Nirjuli.
- 5.
6. 3.12 Fibre between Nirjuli and Pare.
- 7.
8. 4.12 Fibre between Pare and Ranganadi HEP.
- 9.

10. 5. 12 Fibre Nirjuli and Ranganadi HEP. (Schematic diagram attached in MOM).

The original 24F was dismantled and replaced with new fibre by MUML and Pare Ranganadi was connected over 12F (Refer Point 4a. of MOM which states "Removal of existing 24 Fibre OPGW of ULDC from LILO point (Ext. Tower. No. 09) to Pare" i.e., under MUML jurisdiction. As such, OTDR report received from Pare direction (attached) shows fibre issue at 327 m from Pare FODP) and OTDR report from Ranganadi direction shows link length of 9.81 km. From above, it is seen that the fibre break falls under MUML jurisdiction and thus matter may be taken up with MUML by concerned for further rectification.

Regards
Kamlesh Baishya
Asst.Manager
ULDC

From: Vikash Shankar Singh <vikashiitk308@gmail.com>

Sent: Wednesday, April 24, 2024 8:06 PM

To: ftcnerldc@grid-india.in <ftcnerldc@grid-india.in>; Sundar Moni Mohan <sundarmoni@neepco.co.in>

Cc: neepco edonm <neepco.edonm@gmail.com>; Joy Pal Roy, Manager E M ,KHEP NEEPCO,PAID <joypalroy@neepco.co.in>; Head of Plant Pare HPS <hoppare@neepco.co.in>; saniang@rediffmail.com <saniang@rediffmail.com>; ChaitanyaBh Gorja <gcbharath@neepco.co.in>; Santanu deb <Santanu@neepco.co.in>; Bhaskar Mazumder <bhaskarm@neepco.co.in>; aiegssd@gmail.com <aiegssd@gmail.com>; apslcdc sd <apslcdc.sd@gmail.com>; eesldcitaap@gmail.com <eesldcitaap@gmail.com>; mviswanadh@grid-india.in <mviswanadh@grid-india.in>; pranjalborkataki@grid-india.in <pranjalborkataki@grid-india.in>; vidyutarunachal@gmail.com <vidyutarunachal@gmail.com>; se transmissioncircle <se_transmissioncircle@rediffmail.com>; bimal swargiary <bimal.swargiary@grid-india.in>; se sopsc <se.sopsc@gmail.com>; nerpc@ymail.com <nerpc@ymail.com>; amareshmallick@grid-india.in <amareshmallick@grid-india.in>; biswajit@grid-india.in <biswajit@grid-india.in>; skldeep@grid-india.in <skldeep@grid-india.in>; hop plphs <hop.plphs@neepco.co.in>; exentdii@gmail.com <exentdii@gmail.com>; hodem plphs <hodem.plphs@neepco.co.in>; hop plphs <hop.plphs@neepco.co.in>; Ankit Vaish {अंकित वैश्य} <ankit_vaish@powergrid.in>; Haribabu Rudraraju {रुद्र राजू हरिबाबू} <rudraraju@powergrid.in>; Kamlesh Baishya {कमलेश Baishya} <kamlesh156@powergrid.in>

Subject: Re: Intimation of timeline for revival of PLHPS-Itanagar and PLHPS-Pare HPS Ckt-II

Sir/Madam,

Hardware Healthiness Daily Report

Sl. No.	Servers	Nomenclature	Quantity	Healthy (Yes/No)	Remarks
1	SCADA /EMS Server	DS	2		
2	Identity Server(ID1 & ID2)	ID	2		
3	DTS Server(DT1)	DT	1		
4	CFE Server(FE1 & FE2)	FE	2		
5	ICCP Server(IC1 & IC2)	IC	2		
6	DDS Server(DD1)	DD	1		
7	Centralised Management Server	CM	1		
8	ISR Server(IS1 and IS2)	IS	2		
9	NMS Server(NS1 & NS2)	NS	2		
10	SAN Management Server(SS1 & SS2)	SS	2		
11	SAN Box(SB1 & SB2)	SB	2		
12	NAS Box(NB1 & NB2)	NB	1		
13	Data Replica Server(RD1 & RD2)	RD	2		
14	Web Server	WB	2		
15	Terminal Server	TL	6		

Sl. No.	Switch	Nomenclature	Quantity	Healthy (Yes/No)	Remarks
1	CFE LAN	CW	2		
2	ICCP LAN	PW	2		
3	Internal DMZ LAN	IW	2		
4	SAN /NAS LAN	BW	2		
5	Server Mnt. Console LAN	MW	2		
6	Data LAN	RW	1		
7	External DMZ LAN	EW	2		

Sl. No.	Routers	Nomenclature	Quantity	Healthy (Yes/No)	Remarks
1	RTU Router	RR	2		
2	ICCP Router	IR	2		
3	DDS Router	DR	1		
4	ISP Router	SR	1		

Sl. No.	Firewall	Nomenclature	Quantity	Healthy (Yes/No)	Remarks
1	Internal Firewall	IF	2		
2	External Firewall	EF	2		

Sl. No.	Consoles	Nomenclature	Quantity	Healthy (Yes/No)	Remarks
1	Operator Console	OC	7		
2	UPS Console	UC	1		
3	Training Console	TC	2		
4	KVM Switch	KW	2		
5	Server Management Console(SC1)	SC	1		
6	Development Console	DC	1		

Sl. No.	Display	Nomenclature	Quantity	Healthy (Yes/No)	Remarks
1	GPS Clock	CK	1		
2	Time Display	TD	1		
3	Day Display	YD	1		
4	Frequency Display	FD	1		
5	ABT Display	AD	1		

Sl. No.	Printers	Nomenclature	Quantity	Healthy (Yes/No)	Remarks
1	Multi-functional printer		2		

Sl. No.	VPS	Nomenclature	Quantity	Healthy (Yes/No)	Remarks
1	Video Projection System (70" LED based)(8*3)		32		
2	VPS Controller		1		

Sl. No.	Auxillary Power Supply	Nomenclature	Quantity	Healthy (Yes/No)	Remarks
1	40 kVA (32kW at 0.8 pf) UPS running in parallel		2		
2	VRLA type Battery banks for above UPS (each bank of 76.8 kVAH)		2		
3	Input ACDB (150kVA rating)		1		
4	Output ACDB (100kVA rating)		1		
5	125 kVA DG set		1		
6	80 kVA isolation XFMR		1		

Sl. No.	Video Calling System	Nomenclature	Quantity	Healthy (Yes/No)	Remarks
1	2X2 video wall				
2	Microphone				
3	Camera				
4	VC Remote				

RLDC/SLDC Representative

GE Representative

Software Healthiness Daily Report

Sl. No.	Switch	Healthy (Yes/No)	Remarks
1	SCADA		
2	ICCP Communication		
3	CFE Communication		
4	SOE Viewer		
5	Dispatcher Training Simulator (DTS)		
6	eDNA Trends		
7	Network Management System		
8	Data Historian Software (eDNA)		
9	Data Historian Software (HDR)		
10	Software for SAN and NAS		
11	Report development and Generation Software		
12	EMS Functions		
13	Web Server Application		
14	Host based IDS for all machines in External DMZ zone		
15	Software for Data Replica server		
16	Software for Centralised Management System		
17	Software for Web Server		
18	Anti Virus Software for all machines		
19	External Firewall License		
20	Internal Firewall License		
21	Servers windows license		
22	Operating console license		

RLDC/SLDC Representative

GE Representative

Minutes of the Meeting of Discussion on Detailed Project Report (DPR) of SCADA/EMS Upgradation Project – ULDC Phase III in North Eastern Region held via online mode on 3rd May 2024.

Date: 3rd May 2024

Venue: Online Mode

Time: 11:00 Hrs

CGM (SL), NERLDC welcomed all the members for the meeting. He pressed on the matter that AMC for SCADA/EMS ULDC Phase II for few of the states of NER have expired, which is a matter of concern and those NER SLDCs should give due attention to this matter and award the extended AMC at the earliest to get proper support from M/S GE. He further added, Budgetary offers have been received from M/S L&T and M/S GE for the Upgradation of SCADA/EMS ULDC Phase III. To sensitize the states about signing of DPR, this meeting has been organized. It was also informed that, the Draft DPRs (Part A) for each State has already been circulated to each state and they are required to work on getting Management approvals of the same and submit it to PSDF Secretariat through NERPC with a copy to NERLDC at the earliest.

Member Secretary, NERPC appreciated NERLDC for the efforts that they have made for the SCADA/EMS project till now. He again reiterated that PSDF grant has already been approved for this upgradation project. DRPs have not been signed by any of the states yet. Same should be done at the earliest. He also emphasized that, in the upgraded SCADA Systems, Cyber Security aspects will also be met as stipulated in CEA/CERC guidelines.

ED, NERLDC emphasized regarding preparation and signing of DPRs and submission to PSDF Secretariat through NERPC at the earliest.

Afterwards there was a small round of introduction of all the participants present during the meeting.

1.0 General Discussion

Manager, NERLDC presented the highlights of the present status of the ULDC-Phase III Project for NER States.

During the presentation, NERLDC highlighted that written confirmation regarding finalization of the Backup SLDC of Arunachal Pradesh is yet to be received. In reply, SLDC Arunachal Pradesh confirmed that Pasighat has been already fixed. A written confirmation will be sent to NERLDC soon.

2.0 Discussion Regarding AMC Extension for ULDC Phase -II

Extended AMC of Assam will expire on 11-11-2024. Member Secretary, NERPC requested SLDC Assam to talk with M/S GE for further extension of the AMC for 1-2 years. Assam SLDC stated that, they shall request M/s GE to extend support for another 2 years.

It has been highlighted that M/S GE has been providing support without AMC to Manipur, Mizoram and Tripura.

On enquiry, SLDC Tripura mentioned that MD, TPTL has already approved the extension of AMC on 03-05-2024, and LOA will be issued at the earliest. They further added later on, due to General Elections Code of Conduct has been imposed, so they are unable to award the amended LOA. It will be done once the Code of Conduct is lifted. This was already communicated to M/s GE by SLDC Tripura.

SLDC Manipur has also confirmed that internal approval (from Board) has been taken by them and in 2-3 weeks, LOA will be issued.

SLDC Mizoram confirmed that internal approval has been obtained and that LOA issuance will be done within a week's time.

Manager, NERLDC informed that, a paragraph may be inserted in the draft DPRs which gives special emphasis on the difficulties faced due to the hilly nature and remoteness of the terrain in NER. The paragraph is given below and may be inserted in Format A4, section 2.1 Cost Estimate:

"Additionally, the hilly terrain of the state presents unique challenges that may contribute to higher costs. Transportation of equipment and materials across difficult, hilly regions increases logistical complexities and expenses. These factors, combined with the need to maintain reliable connectivity and system performance across the rugged landscape, result in elevated expenses compared to projects in less challenging environments.

As a result, the overall cost estimate for the SCADA/EMS upgradation, including the Comprehensive AMC, is expected to be higher to account for these logistical and infrastructural hurdles."

3.0 Preparation of Part A (Upgradation of SCADA/EMS) and Part B (Construction of Backup SLDC) of DPRs by NER States.

3.1 Assam:

SLDC Assam has confirmed that Part B of DPR has been prepared by them and it has been routed for internal scrutiny. Same will be submitted shortly. CGM (SL), NERLDC requested SLDC Assam to share the Draft Part B of DPR with NERLDC so that common

format can be prepared and shared with other NER States. SLDC Assam has agreed to share the same at the earliest. SLDC Assam has communicated that they have received budgetary estimates for Part B of DPR amounting to Rs. 24.0 crores.

Regarding the Part A, SDLC Assam has mailed some queries to NERLDC. CGM (SL), NERLDC communicated that the reply on their queries will be provided after discussion with CC-Engineering, GRID-INDIA.

3.2 Manipur:

SLDC Manipur enquired about incorporation of Email Servers in the BoQ. CGM (SL), NERLDC conveyed that since email servers are a part of IT infrastructure; so the same cannot be clubbed with OT.

SLDC Manipur also enquired whether AMC charges are included within the scope of this project/PSDF Fund, to which CGM (SL), NERLDC confirmed that 7 years (1 year DLP + 6 years AMC) support by vendor is included in the scope of this project.

CGM (SL), NERLDC mentioned that, manpower shall be required for manning the Back-up SLDC and Main SLDC, States shall be liable for ensuring the same.

Regarding the Part B of DPR, SLDC Manipur highlighted that the Civil Division is preparing the Part B of DPR and the same will be done within 2 weeks.

3.3 Mizoram

SLDC Mizoram highlighted that Part B of DPR has already been submitted to NERPC. However, NERLDC informed that, the same was also checked by them and it was not found to be in proper format of PSDF. SLDC Mizoram told that they will modify the same and resubmit after receiving the draft DPR format of Part B from NERLDC.

3.4 Arunachal Pradesh

SLDC Arunachal Pradesh mentioned that Part A will take a few more days for completion.

Regarding Part B, SLDC Arunachal Pradesh mentioned that Draft DPR has been prepared and the same will be shared with NERLDC.

3.5 Nagaland

SLDC Nagaland had a query regarding Part A- BoQ, where SMS services have been omitted. NERLDC clarified that the same has already been deliberated on 22nd Nov 2023

meeting at NERLDC, Guwahati and only the integration part of SMS and Internet had been kept in the scope of the vendor and SMS Services needs to be taken by the respective user/owner. As per statutory guidelines by TRAI, SMS and Internet to be in the name of owner.

Part B is yet to be prepared. They have requested for the draft format from NERLDC. It was assured that, upon receiving the formats, from SLDC Assam/Arunachal Pradesh, NERLDC would forward the same.

SLDC Nagaland had asked for final date of submission of the signed DPRs. NERLDC requested that maximum of two weeks' time can be permitted as the whole process from PSDF Approval to Tendering will take a great amount of time.

3.6 Meghalaya

SLDC Meghalaya informed that Backup SLDC location is finalized and they are preparing Part B. They have also requested for the draft format from NERLDC. Upon receiving the formats from SLDC Assam/Arunachal Pradesh, NERLDC will forward the same.

Regarding Part A, SLDC Meghalaya informed that few days' will be required for signing the DPR.

They also raised the query regarding "RTU Maintenance not included in the L&T quotation". To which it was clarified that, an email reply has been received from the Vendor that the same is included in the budgetary estimated amount. Reply email has been shared with all the States on 1st May'24 for inclusion in the DPRs.

3.7 Tripura

Regarding the Part A, SDLC Tripura has mailed some queries to NERLDC. CGM (SL), NERLDC communicated that the reply on their queries will be provided after discussion with CC-Engineering, GRID-INDIA.

Regarding Part B, SLDC Tripura informed that the Civil Department is looking after the same and will be done in a week's time.

Member Secretary, NERPC requested all SLDCs to submit the DPRs within 2 (two) weeks' time.

The meeting ended with thanks to all the participants and subsequent updates from the states will be taken in the next NETeST Meeting.

The list of Participants in the meeting are attached below:

SI No.	Name	Organization	Designation	Phone No	Email ID
1	K B Jagtap	NERPC	Member Secretary		kb.jagtap@gov.in
2	Amaresh Mallick	NERLDC	ED, NERLDC	9436302720	amareshmallick@grid-india.in
3	S P Barnwal	NERLDC, Guwahati	CGM, SL	9433041812	spbarnwal@grid-india.in
4	Lalawmpuia Chawngthu	SLDC Mizoram	AE	8730843706	awmach.9@gmail.com
5	Shampa Sen	SLDC Tripura, TPTL	Sr. Manager	9436120263	smpsen@rediffmail.com
6	N Romeo Singh	SLDC Manipur	Deputy Manager	9612657280	romeo.ningombam@gmail.com
7	Steffi Okram	SLDC Manipur	Manager	8974724715	steffiokram@gmail.com
8	D J Lyngdoh	MePTCL	SE	9863063375	david.jeremy6@gmail.com
9	M K War	SLDC, Meghalaya	EE	9436116496	eesmsldcmeg@gmail.com
10	Y Iakai	SLDC, Meghalaya	AEE	9402133552	iakaiyomon@gmail.com
11	E.Pongmei Phom	SLDC Nagaland	SDO	8132862504	pongmeinew1@gmail.com
12	V.Lalhmingliana	SLDC Mizoram	JE	9612763052	v.mahminga@gmail.com
13	Lalremruata Sailo	SLDC Mizoram	JE	9612614372	
14	H.Lalruatkima	SLDC Mizoram	Sr.EE	9862925462	krhlondo71@gmail.com
15	Gargi Dutta	NERLDC, Shillong	CM	9436335231	gargi@grid-india.in
16	Shakti Mayank Singh	NERLDC, Guwahati		8299085576	Shaktimayank@grid-india.in
17	Gaurav Bhattacharjee	NERLDC, Guwahati	AM	9402304210	
18	Toushita Jigdung	SLDC, Asaam	DGM(logistic)	9707134351	
19	Ranjan Goswami	SLDC, Asaam	AGM		
20	Rupjyoti Das	SLDC, Asaam	DM		
21	Nilotpal Bhattacharjee	SLDC, Asaam	AM		
22	Palash Jyoti Borah	NERLDC, Guwahati	Manager	8761093397	palash14.india@grid-india.in
23	P Tiakaba Yimchunger	SLDC Nagaland	JE	8974020151	tiaquenger@gmail.com
24	Purik Buchi	SLDC, Arunachal Pradesh		9366118384	

REGIONAL COMMUNICATION AUDIT REPORT

General Information:

1	Substation Name	
2	SS Voltage level	
3	Date of commissioning of the substation	
4	Region & State / Auditee	
5	Audit Date	
6	Name of the Utility which owns the SS	

Details of Audit Team Members :

SL	Name	Designation	Organization
1			
2			
3			
4			

Attached Documents, if any

SL	Name of the document	Original / Signed / Copy
1		
2		
3		
4		
5		
6		
7		
8		
9		
10		
11		
12		
13		
14		
15		
16		
17		

Communication Channels and Equipments Audit Format

(A) List of channels in usage for data (64 kbps, 104, PMU, VC, 101) / Voice / Protection circuits / Others :

Sl	Description (64 kbps, 104, PMU, VC, 101) / Voice / Protection circuits / Others)	Source	Destination	Channel Routing	Ownership details of terminal equipment / Links
1					
2					
3					
4					
5					
6					
7					
8					

(B) List of terminal communication equipments :

Sl	Name of Station	Equipment Type (SDH / PDH / Radio / VSAT / EPABX)	Make / Model	Ownership
1				
2				
3				
4				
5				
6				
7				
8				

(C) Communication System Details :

I. SDH Equipment

(1) Card Details :

Slot No	IP Address & Path / Direction Name	Card Details	Place a ✓ mark if on usage, else Write as "Spare"	Whether Card is healthy / Faulty ? (H / F)	Cards Redundancy available (Yes / No)	Power Supply Card / Optical Card (Yes / No)	MSP configured ? (Yes / No)	Action Plan for faulty cards	Other Information, if any
1									
2									
3									
And so on									

(2) Whether equipment is time synchronized : Yes / No

If Yes, how is it being done ?

(3) Failures during last Fin. year / since last Audit :

Particulars	Number of failures of Card / Power Supply	Reason for failures	Measures taken for rectification
Card		(i) (ii) (iii)	(i) (ii) (iii)
Power Supply		(i) (ii) (iii)	(i) (ii) (iii)

(4) Configuration of the Node :

Name of Equipment	Number of Nodes	Number of directions	Name of Directions	Number of links down, with details	Details of corrective action, if any, taken

(5) Preventive maintenance schedule and its compliance :

Date of Last Preventive maintenance	Maintenance carried out as per schedule ? (Yes / No)	Whether all the defects have been attended ? (Yes / No) Give details

II. PDH Equipment

(1) Card Details :

Slot No	IP Address	Card Details	Place a ✓ mark if on usage, else Write as "Spare"	Whether Card is healthy / Faulty ? (H / F)	Cards Redundancy available (Yes / No)	Power Supply Card / Optical Card (Yes / No)	MSP configured ? (Yes / No)	Action Plan for faulty cards	Other Information, if any
1									
2									
3									
And so on									

(2) Whether equipment is time synchronized : Yes / No

If Yes, how is it being done ?	

(3) Failures during last Fin. year / since last Audit :

Particulars	Number of failures of Card / Power Supply	Reason for failures	Measures taken for rectification
Card		(i) (ii) (iii)	(i) (ii) (iii)
Power Supply		(i) (ii) (iii)	(i) (ii) (iii)

(4) Configuration of the Node :

Name of Equipment	Number of Nodes	Number of directions	Name of Directions	Number of links down, with details	Details of corrective action, if any, taken

(5) Preventive maintenance schedule and its compliance :

Date of Last Preventive maintenance	Maintenance carried out as per schedule ? (Yes / No)	Whether all the defects have been attended ? (Yes / No) Give details

III. OPGW / Optical Fibre Details

Number of Directions	Name of Direction	No. of Pairs	No. of Fibers used	No. of spare & healthy Fibers	Unarmoured cable laid within PVC/Hume duct pipe ?	Fibre Count in OPGW ? Whether matching with Approach cable to FODP ?	Overall Optical Fibre Path Attenuation (dB/km)	Power Received	Conformation to Compliance of CEA Standards

IV. Healthiness of Auxiliary System :

(1) Details of 2 independent Power Sources :

Source	Commissioning Date	Battery Back up (Hour)	Battery capacity (AH)	Supply Voltage (V)	Healthiness of Battery (Yes / No)	Make of Charger	Charger Capacity (A)	Periodicity of Maintenance Schedule	Date of Last 2 Actual Maintenance carried out	Remarks
1										
2										

(2) Conformation to Compliance of CEA Standards :

V. Healthiness of Earthing of each equipment :

Sl	Equipment	Status on Healthiness of Earthing

VI. Details of Voice communication available between Sub-station and Control Centre :

Sl	Voice communication (Sub-station - Control Centre)	Status on Healthiness of Voice communication	Healthiness of air-conditioning of communication room as per OEM recommendation

VII. PLCC Details :

Number of Panels	Make and Model	Direction	Frequency (Tx & Rx) KHz	Status on Healthiness	Last preventive maintenance		Details of defects, if any, attended	Status of Availability of Spares	Conformation to Compliance of CEA Standards
					Schedule	Actual			

VIII. Radio Communication Details :

Number of Equipments	Make and Model	Status on Healthiness	Last preventive maintenance		Details of defects, if any, attended	Status of Availability of Spares	Conformation to Compliance of CEA Standards
			Schedule	Actual			

IX. Data Retention : (i) **Earliest Date of availability of data :** _____
 (ii) **Historical data availability :** _____ days.

X. Control Command Delay : (i) **Time delay in seconds from Control Centre for SCADA :** _____ Seconds
 (ii) **Time delay in seconds from Control Centre for WAMS :** _____ Seconds

XI. Wide Band Network : (i) **Absolute channel delay in protection applications :** _____ ms
 (ii) **Channel delay asymmetry in protection applications :** _____ ms
 (iii) **Switching Time delay to alternate path/route during failure of one path :** _____ ms

XII. Any other information :

**Audit Team Member
NERPC**

**Audit Team Member
Co-Ordinator**

**Audit Team Member
PGCIL (Internal / External)**

**Audit Team Member
State (Internal / External)**

CYBER SECURITY MEASURES IMPLEMENTATION STATUS FOR NER SLDCs (AS ON 13.05.2024)

ANNEXURE-I

SN	Cyber Security Measures	Arunachal Pradesh	Assam	Manipur	Meghalaya	Mizoram	Nagaland	Tripura
1	Preparation and approval of Cyber Crisis Management Plan (CCMP) for SLDCs	Final CCMP approved by CERT-In. Rev-1 to be issued after incorporation of the comments from CERT-GO.	Final CCMP approved by CERT-In. 3rd Revised version of CCMP issued on 14-09-22 and approved by CERT-In.	Final CCMP approved by CERT-In.	Final CCMP approved by CERT-In. Revision 1 in progress	Final CCMP approved by CERT-In. Revision under process.	Final CCMP approved by CERT-In.	Final CCMP approved by CERT-In.
2	Implementation status of Information Security Management System (ISMS) i.e., ISO 27001 and certification audit for ISO-27001	Implemented. Arunachal SLDC received certification for ISMS (ISO 27001:2013) on 19.09.2023. Rev1 dtd. 06.10.2023. Expiry of certificate 31.10.2025.	Implemented. Assam SLDC has received certification for ISMS (ISO 27001: 2013) on 09.07.22. 1st Surveillance Audit has been carried out in 4th July'23. Report received and Certificate of First Surveillance Audit received on 08.07.2023.	LOA issued to CDAC, Hyderabad on 3rd Nov'21 for Implementation of ISMS (ISO-27001). Implmnetation could not be completed as CDAC Hyderabad team could not visit the Manipur. Work has been extended till 31-12-2024.	Implemented. Meghalaya SLDC has received certification for ISMS (ISO 27001: 2013) on 08.07.22. 1st Surveillance Audit has been carried out in June'23 and certificate received.. Certification validity extended up to 8.07.2024.	ISO 27001 being executed. VAPT completed and mitigation to be done. ISMS stage-1 audit done. Stage-2 audit pending to get certification.	Implemented. Nagaland SLDC has received certification for ISMS (ISO 27001: 2013) on 01.06.23.	Contract has been awarded to Certifying Agency and implementation is in final stage.
3	Status of VA-PT on OT systems	Done for FY 22-23.	Done for FY 22-23.	Done for FY 23-24.	Done for FY 22-23. and for FY 2023-24 conducted on 18th to 23rd March 2024.	Done for the year 2024	Done for FY 23 - 24	Done for FY 23-24.
	i) Date of Last VA-PT (OT):	24/03/2023- 28/03/2023	17/02/2023 - 21/02/2023	21/01/2024-24/01/2024	18/03/2024 to 23/03/2024	Jan-24	10/01/2024-13/01/2024	29/01/2024- 01/02/2024.
	Submission of latest VA-PT report carried out on OT systems of SLDC for onward submission to MoP		Revised Report Received. shared with MoP	Reports received and fixed the vulnerabilities. Awaiting final report.	Reports received and will be submitted to MoP	Report not received yet	Reports received and submitted to MoP	Report for FY 24-25 submitted by GE in 22nd April 2024.
	ii) Due date for Next Audit / Plan for next audit (OT) :	01-02-2024	17-02-2024 scheduled to being on 13.05.2024	July-August-2024	See (i) above	01-01-2025	Next year(2025)	-
4	Status of VA-PT on IT systems (to be done once in every six months)	No IT infrastructure is present in the SLDC. Shall be carried out after implementation of SAMAST and the related IT infrastructure.	Last VAPT completed on 07.02.2024; reports received.	Phase -1 of VAPT for IT systems has been completed. Phase-2 was scheduled in June'23; which is still pending due to prevailing situation of unrest in Manipur. It will be done soon.	Last VAPT completed in March-2024 Reports received and mitigation is being carried out.	VAPT done on March 2024, mitigation to be done.	VAPT on IT systems done from 24 Aug 2023 to 28 Aug 2023.	Last VAPT of IT system completed in March-2023. Reports recieved from CDAC.
5	Notification of identified systems at SLDCs as Critical Information Infrastructure (CII)	Final revised CII document has been submitted to NCIIPC after incorporation of comments on 19.05.2023. NCIIPC requested for re-apply along with transmission and distribution utility. SLDC Arunachal requested NCIIPC to declare SLDC Arunachal as CII in initial step.	Identified Systems of SLDC, Assam had been declared as CII by NCIIPC on 10.06.2022. Notification of CII as Protected Systems has been issued by State Govt. on 11.08.2023.	As instructed by NCIIPC new assessment document was prepared merging the transmission utility (MSPCL) and SLDC Manipur. As per latest communication from NCIIPC, the document was throroughly reviewed by NCIIPC eastern zone and forwarded to NCIIPC headquarters. Awaiting further instructions from NCIIPC	Identified Systems of SLDC, Meghalaya had been declared as CII by NCIIPC on 31.12.2021. Notification of CII as Protected Systems has been issued by State Govt. on 18.04.2022.	Final revised CII document had been submitted. Forwarded by East Zone and presently under approval at NCIIPC head office in New Delhi.	Identified Systems of SLDC, Nagaland had been declared as CII by NCIIPC on 31.12.21. Notification of CII as Protected Systems still pending with the State Govt.	The CII is yet to be approved by NCIIPC. Submitted on 30.09.2023 through email to coord.east@nciipc.gov.in NCIIPC has reviewed the document and given some assignment for addition/alteration in this document. However this assignment is yet to be re-submitted to NCIIPC from SLDC Tripura.
6	Date of last Risk Assessment by NCIIPC (once in every 2 years):	Not done	Not done	Not done	Not done	Not done	Not done	Not done

CYBER SECURITY MEASURES IMPLEMENTATION STATUS FOR NER SLDCs (AS ON 13.05.2024)

ANNEXURE-1

SN	Cyber Security Measures	Arunachal Pradesh	Assam	Manipur	Meghalaya	Mizoram	Nagaland	Tripura
7	Compliance of advisories from CERT-In, NCIIPC & other statutory agencies.	Being complied for OT	Being complied	Being complied	Being complied	Being complied	Being complied	Being complied
i	To be updated in Portal for monthly compliance by 10th of every month.	Not updated in the portal	Being Updated in Portal	Being Updated in Portal	Being Updated in Portal	Being Updated in Portal	Being Updated in Portal	Being Updated in Portal
ii	For CERT-In weekly advisories to be complied within 5 days: To be uploaded in the portal after completion.	Being Updated in Portal	Being Updated in Portal	Being Updated in Portal	Being Updated in Portal	Being Updated in Portal	Being Updated in Portal	Being Updated in Portal
ii	Compliance of advisories from Cyber Swachhta Kendra (CSK)	Being Resolved. No new alerts.	Being Resolved. No new alerts.	Being Resolved. No new alerts.	Being Resolved. No new alerts.	Being Resolved. No new alerts.	Being Resolved. No new alerts.	Being Resolved. No new alerts.
8	Compliance of Recommendations of CERT-GO as per SLDC Maturity Model assessment:							
9	Status of Nomination of CISO:	Done	Done	Done	Done	Done	Done	Done
	Alternate CISO (if any):	Nomination of new Alt. CISO is in progress.	Yes	Yes	Yes	Yes	Yes	Yes
10	Cyber Security Certification: (Training attended)	No	Yes. Basic level training and certification on Cyber Security for Power Sector Professionals completed by 7 officers.	Yes. (2 Officials)	Yes. (11 officials undergone Basic level certification course from NPTI and 2 had undergone Intermediate level training in March 2024)	Yes (9 Official trained in Two Weeks Basic Level Training and Certification Program on Cyber Security)	1 Official trained for Basic Level Certification Course(NPTI) in Sep 2023.	Yes. 1 Official (Attended by Alternate CISO)
11	IT - OT Integration:	Not present	Present between SAMAST and SCADA	Present Between SAMAST and SCADA	Present between SAMAST and SCADA. As discussed with NCIIPC during ISSC meeting, the same will be discontinued.	SCADA & SAMAST integration done	Under process for integration between SAMAST and SCADA.	-
12	SOC Implementation status:		Under discussion with vendors for obtaining proposal for preparation of DPR.	DPR preparation phase	Under discussion with Management. (However, main concerns are regarding AMC funding and manpower.)	Under cosideration	Discussed with the Head Management and may agree on the condition 100% AMC is funded.	-

North Eastern Regional Power Committee

MINUTES OF THE SPECIAL REVIEW MEETING

NE-TeST

Date : 07th March, 2024 (Thursday)

Time : 11:00 Hrs

Venue : “Hotel Royale de’ Casa”, Guwahati.

The List of Participants is attached at **Annexure – I**.

Shri K. B. Jagtap, Member Secretary, NERPC welcomed all the participants. He informed that the following agenda items needs urgent attention and deliberation.

A. ITEMS FOR DISCUSSION

A.1 Establishment of redundant fibre path between NERLDC and NEHU for reliability of power system communication link till RLDC.

On 05-01-2023 and 06-01-2023, there were two incidents of fibre cut between NERLDC and NEHU, during the incident all communications links, such as internet, all ULDC links of ICCP, URTDSM, VOIP, RTUs and all POWERTEL links catering the functionality of NERLDC real time system were affected. Consequently, NERLDC control room was not having any data of grid station which led RLDC to operate grid blindly. Due to outage of this link SLDC and NLDC were also not able to receive data from NERLDC. This 24-core fibre currently runs partially as OPGW on 132 kV NEHU-Kheliriat line and partially as UGFO cable. The fibre is under the ownership of POWERTEL & ULDC has been allotted some pair of fibres from it.

Considering the critical functions of LDCs, it is requested to ULDC-POWERGRID to lay 24 core FIBRE between NERLDC Shillong and NEHU, which should be in physically different path to that of POWERTEL fibre and complete ownership of new fibre should be with ULDC-POWERGRID.

During 24th NETeST Meeting, the forum requested NERTS to include this link in the reliable communication project as this is a very important link in the ULDC network under the head of central sector links. Further, Member Secretary, NERPC suggested the forum to carry out a separate meeting between MePTCL, POWERGRID-ULDC,

Minutes of Special Review Meeting held on 7th March, 2024
POWERTEL, NERLDC and NERPC to discuss the issues raised by MePTCL regarding Powertel link.

During 25th NETeST meeting, as per request of the forum ULDC-POWERGRID agreed to lay 24 core UG FIBRE between NERLDC Shillong and 132kV NEHU-Kheliriat line- I Tower no.25 under Reliable Communication Scheme.

During the Special NETeST Sub Group Meeting held on 31st May, 2023, MePTCL informed the forum that they desire to BOO (Build – Own – Operate) the OPGW in their Transmission lines. In this regard, POWERGRID informed that due to system constraint, if required, the 7.532KM NEHU – T25 link can be decapitalized subject to TCC/RPC approval. CTU informed the forum that the ownership and maintenance accountability of these links has to be established before such proposed transfer.

In 27th NETeST meeting, it was decided that separate meeting shall be conducted.

Deliberation of the forum:

(a)132 kV NEHU – Khliehriat CKT-I

NERLDC informed that data to NERLDC for grid operation was to be ensured via 12F of 132 kV NEHU – Khliehriat CKT II (connected in Tower No. 23) as a main path and 132 kV NEHU – Khliehriat CKT-I (Connected in Tower No. 25) as a protection path. However, Under MW vacation project, 7.532KM OPGW-24F has been laid from 132 kV NEHU S/s to Tower No. 25 of 132 kV NEHU – Khliehriat CKT-I and in the 24th TCC/RPC meeting, approval was accorded to ULDC-POWERGRID to lay 24 core UG FIBRE between NERLDC Shillong and 132 kV NEHU-Kheliriat line I Tower 25.

POWERGRID informed that the work in this regard has been initiated. However, POWERGRID mentioned that further NCT approval may be required for carrying out the UGFO works from T-25. NERLDC informed that POWERTEL has installed an ADSS cable for fiber connectivity between T-25 of the 132 kV NEHU-Mawlyndep-Mustem-Khliehriat line (Ckt-I) and NERLDC, Shillong for their commercial purpose and has not provided any fiber to NERLDC for ULDC purpose/application. The forum asked POWERTEL to share the copy of approval for the ADSS cable installed by them within a month to NERLDC /NERPC. POWERTEL agreed to share the copy of approval for the ADSS cable installed by them. POWERTEL also informed the forum that significant losses were being observed in the ADSS cable, limiting its full utilization.

MePTCL also informed that they would like to install and commission a 48F link in the NEHU-Mawlyndep-Mustem-Khliehriat CKT I line under State Reliable Scheme 90:10 or any other government scheme. MePTCL submitted the followings (for the necessity and benefits of installing 48F in lieu of 24F):

- (a) The cost of 48F and 24F are comparable and varies around 10%- 20%
- (b) Additional no. of fiber will ensure, sufficient channel availability for ULDC, SPS, Digital Protection, etc. i.e., it will also enhance the system reliability.
- (c) After using the fibers for system reliability, MePTCL can use the balance fiber for commercial purpose for additional revenue from their existing infrastructure for financial viability.

AEGCL also informed the forum that they also desire to use the fiber installed in their Transmission infrastructure for deriving additional revenue as the present revenue shared with them is too low. POWERGRID informed that the as per CERC regulations, sharing of benefits is being done. CTUIL is the nodal authority which ensure sharing of benefits is being reflected in the bills. MePTCL referred to the special meeting held on 31-May-2023 in NERPC and informed that they are yet to receive the details of payments/benefits accrued from telecom business towards reduction in POC charges / transmission charges for Meghalaya (utilization of the ULDC OPGW link by POWERTEL). AEGCL also requested that Assam also wants the same information. The forum suggested that CTUIL should furnish the details as requested by MePTCL & AEGCL within a month.

The forum noted that 7.532 KMs of 24F OPGW is existing between 132 kV NEHU S/s and Tower 25 of 132 kV NEHU-Kheliriat line I. In this connection, POWERGRID informed that the 7.532 KMs of OPGW was commercialized in 2014 and 10 years of useful life have been completed. After DOCO of the proposed 48F from NEHU-Mawlyndep-Mustem-Khliehriat CKT I, this section needs to be decapitalized. The forum opined that implementation of the proposed 48F by MePTCL will require its inherent time (as it includes DPR preparation and subsequent internal approval followed by submission and approval of PSDF or any other funding agency and its subsequent project implementation), as such there may not arise the need for decapitalization of the 7.532 KMs of 24F OPGW implemented by POWERGRID under MW vacation. However, in case the DPR is finalized and the project is awarded before completion of useful life of the OPGW, the same has to be decapitalized and the necessary charges need to be reimbursed to POWERGRID.

The forum also noted that the proposal of MePTCL for implementing a 48F link in the NEHU-Mawlyndep-Mustem-Khliehriat CKT I, approval obtained in the 24th TCC/RPC meeting to lay 24 core UG FIBRE between NERLDC Shillong and 132 kV NEHU-Kheliriat line I Tower 25 shall require modification and accordingly it can be taken in next RPCs meeting. In this connection, NERLDC proposed the following fiber distribution (**Attached as Annexure A-1**):

SN	From	To	Number of Fiber
1	NEHU	NERLDC	24F
2	NEHU	Mawlyndep	24F
3	NERLDC	Mawlyndep	24F
4	Mawlyndep	Mustem-Khleiriat	48F

NERLDC also requested for redundant links to NERLDC, Shillong via 400 kV Silchar-Byrnihat Line and 220 kV New Shillong S/s.

NERLDC informed the forum that Regulation 12 of Communication System for inter-State transmission of electricity Regulations, 2017 mandates “All users of CTU, NLDC, RLDCs, SLDCs, STUs shall maintain the communication channel availability at 99.9% annually: Provided that with back up communication system, the availability of communication system should be 100%”. MePTCL assured the forum that the regulation shall be followed strictly and maintenance of the OPGW would be accorded top priority.

After detailed deliberation, the forum agreed to the following (subject to approval of TCC/RPC Forum):

1. **48F OPGW from NEHU to Khliehriat:** MePTCL to propose 48F OPGW on 132 kV NEHU-Mawlyndep-Mustem-Khliehriat line under the State reliable communication Scheme or other suitable schemes. MePTCL to lay and subsequently maintain the link as well.
2. **From T-25 to NERLDC:** POWERGRID to lay and maintain the underground 48F cable under the ongoing reliable communication scheme out of which 24F will be connected to NEHU and the balance 24F to be connected with Mawlyndep. Further, approval shall be taken in the forthcoming TCC/RPC meeting for upgrading the approved 24F to 48F.
3. **Establishment redundant links to NERLDC, Shillong:** The Forum requested POWERGRID-ULDC to survey and check the feasibility of establishing redundant

Minutes of Special Review Meeting held on 7th March, 2024
links to NERLDC, Shillong via 400 kV Silchar- Byrnihat Line and 220 kV New Shillong S/s.

(b) 132 kV NEHU – Khliehriat CKT-II

NERLDC informed the forum that 12F OPGW between NEHU to Khliehriat was laid in ULDC Phase-1 and it has completed its useful life of 15 years. As such replacement of the same has become essential. After detailed deliberation, the forum agreed to the following:

1. **48F OPGW from NEHU to Khliehriat:** The Forum suggested that the OPGW should be upgraded to 48F by POWERGRID in consultation with CTU.
2. **From T-23 to NERLDC:** 12F Underground cable will be upgraded to 24F cable which is already part of the Reliable communication scheme.
3. **From T-23 to NEIGRIHMS:** 24F OPGW is already laid under the NER FO scheme which will be connected to NEHU and Khliehriat.
4. The proposed distribution of the fiber shall be as follows:

SN	From	To	Number of Fiber
1	NEHU	Khliehriat	24F
2	NEHU	NERLDC	12F
3	NERLDC	Khliehriat	12F
4	NEHU	NEIGRHIMS	12F
5	NEIGRHIMS	Khliehriat	12F

5. CEA has constituted a committee under the chairmanship of Member (Power System), CEA for formulating comprehensive guidelines for the usage and sharing of optical fibers (OPGW) for power system applications. NER will follow the guidelines approved by the committee.

The forum noted as above.

Action: POWERTEL, MePTCL, POWERGRID-ULDC, CTUIL, NERLDC & NERPC.

A.2 Replacement of FO link for “NERLDC Shillong – NEHU”, “132 kV Kahilipara – Sarusajai” and “132 kV Kahilipara – Umiam Stg. III – Umiam Stg. I – NEHU”.

Grid-India stated that in the 23rd TCC and NERPC meeting, TCC forum recommended for replacement of OPGW with 24 Fiber for NERLDC Shillong – NEHU”, “132 kV Kahilipara – Sarusajai” and “132 kV Kahilipara – Umiam Stg. III – Umiam Stg. I – NEHU” after RPC and NCT approval. This proposal for replacement shall be substantiated with test report of fiber healthiness. But test report is not available with

Meghalaya SLDC as the links have not been handed over to them by POWERGRID. POWERGRID stated that automatic handing over of the link ownership takes place after completion of fifteen years.

Further deliberations were held regarding ownership and maintenance of the said links. CTUIL stated that since these links are being used for ISTS data & voice communication and this communication shall be kept intact. In view of this CTU requested POWERGRID to clarify the entity who is maintaining the above said lines.

Deliberations in 4th CPM: POWERGRID told that this link contains critical ISTS data and this is the only path for NERLDC connectivity with only 12 Fibers. POWERGRID shared the connectivity diagram of NERLDC (as shown in figure below) and explained the criticality of these links. POWERGRID told that if Meghalaya is ready to maintain and takeover the link they have no issue in handing over these links.

However, GRID-INDIA informed that one of the above links i.e 132 kV Kahilipara – Sarusajai section belongs to Assam which is not vital for NERLDC connectivity and replacement of OPGW on this link shall be considered separately in consultation with Assam. Further, GRID-INDIA stated that 132kV NEHU-Umiam-I-Umiam -III is critical for Grid operation as most of the NERLDC data and AGC data is being routed through this path. In view of this, GRID-INDIA requested CTU for approval for laying of OPGW on these lines to be obtained from NCT. CTU suggested OPGW replacement on all these links may be carried out by single party considering reliability of backbone connectivity to NERLDC. CTU clarified that for approval of OPGW replacement on these lines under ISTS scheme from NCT, the replacement of OPGW shall be substantiated with test report of fiber healthiness which was asked for in the 23rd TCC and NERPC meeting also.

POWERGRID also intimated that Meghalaya is also implementing OPGW on Khleiriat-NEHU section which provides path redundancy for NERLDC. CTU suggested POWERGRID to check whether 48 Fibers can be laid on the “NERLDC Shillong – NEHU” and “132 kV Kahilipara – Umiam Stg. III – Umiam Stg. I – NEHU” paths so that fibers can be shared for ISTS and STU purposes. CTU requested POWERGRID to provide test-report of fiber healthiness of these links so that further review/approval in NETeST/TCC/NERPC & subsequently NCT may be taken up.

Minutes of Special Review Meeting held on 7th March, 2024
will be for ISTS use and the rest 24 fibers for state purpose. This was agreed in the forum. However, Meghalaya stated that they will have to take consent from their management for the said proposal.

Meghalaya (MePTCL) informed that their management has approved the laying and maintenance of 48 fibers by POWERGRID in “132 kV Kahilipara – Umiam Stg. III – Umiam Stg. I – NEHU” subject to the use of 24 fibers for ULDC/System requirement and balance for their own commercial purpose. However, POWERGRID opined that the usage and sharing of the fibers is to be done as per CEA/CERC guidelines/regulations.

Additionally, MePTCL has made a request to connect the 132 kV Kahilipara – Umiam Stage III line at 132 kV Umtru for improved connectivity. The forum agreed to the same and endorsed the establishment of the link as 132 kV Kahilipara – Umtru - Umiam Stg. III – Umiam Stg. I – NEHU. Further discussions regarding the distribution of OPGW between ULDC-POWERGRID and MePTCL to take place in subsequent meetings.

AEGCL highlighted the critical nature of the 132 kV Kahilipara – Umtru OPGW link for Assam, NERLDC, and Meghalaya. AEGCL requested that the OPGW over the 132 kV Sarusajai – Umtru line to be considered as a redundant path. The forum has acknowledged the same and decided to deliberate on it in forthcoming meetings.

The forum noted as above.

Action: MePTCL, AEGCL, POWERGRID-ULDC, CTUIL, NERLDC & NERPC.

Any other item:

A.3 Connectivity of NERLDC Guwahati with Sarusajai and Umiam bypassing Kahilipara for its redundancy.

During a meeting held on August 8th, 2022, involving Communication-AEGCL, SLDC Assam, NERLDC Grid-India, and ULDC-POWERGRID, several decisions were made. It was agreed that POWERGRID would lay two 24-core fiber optic cables from NERLDC Guwahati to Gantary of Kahilipara. At Gantary, a Joint Box would be installed, facilitating the connection of one cable from NERLDC to the Sarusajai direction and the other cable to the Umtru direction.

Additionally, it was decided that AEGCL would upgrade the existing 12-core Optical Ground Wire (OPGW) over the 132 kV Kahilipara – Sarusaji link to a 24-core OPGW.

Deliberation of the sub-Committee:

MS, NERPC advised NERLDC to put it as an agenda item in the forthcoming NETeST meeting for further discussion and consideration.

The Sub-Committee noted as above.

Action: NERLDC.

Annexure-I

List of Participants in the of Special Review Meeting held on 7th March, 2024

SN	Name & Designation	Organization	Contact No.
1	Sh. Arup Sarmah, AGM, SLDC, AEGCL	Assam	09707854367
2	Sh. J. Hynniewta, Director (T), MePTCL	Meghalaya	-
3	Sh. D. J. Lyngdoh, SE-I (Trans), MePTCL	Meghalaya	-
4	Sh. B. Narry, EE, MePTCL	Meghalaya	-
5	Sh. C. W. Chen, AEE, MePTCL	Meghalaya	09863093311
6	Sh. Amaresh Mallick, ED	NERLDC	09436302720
7	Sh. S. Mondal, CM	NERLDC	09433041851
8	Sh. Sakal Deep, AM	NERLDC	09774528218
9	Sh. Anupam Acharya, CM	PGCIL	-
10	Sh. M. K. Baruah, Sr.GM	PGCIL	-
11	Sh. Kamlesh Baishya, AM	PGCIL	-
12	Smt. Indrani Kakati, Sr. DGM	POWERTEL	-
13	Sh. Hiranmoy Duwarah, DM	POWERTEL	-
14	Sh. K. B. Jagtap, Member Secretary	NERPC	-
15	Sh. Rajib Das, AEE	NERPC	09954947474



Proposed Solution of NEHU-NERLDC- Khliehriat Ckt-1 & Ckt-2

-By NERLDC

NEHU-NEGIRHIMS Redundancy

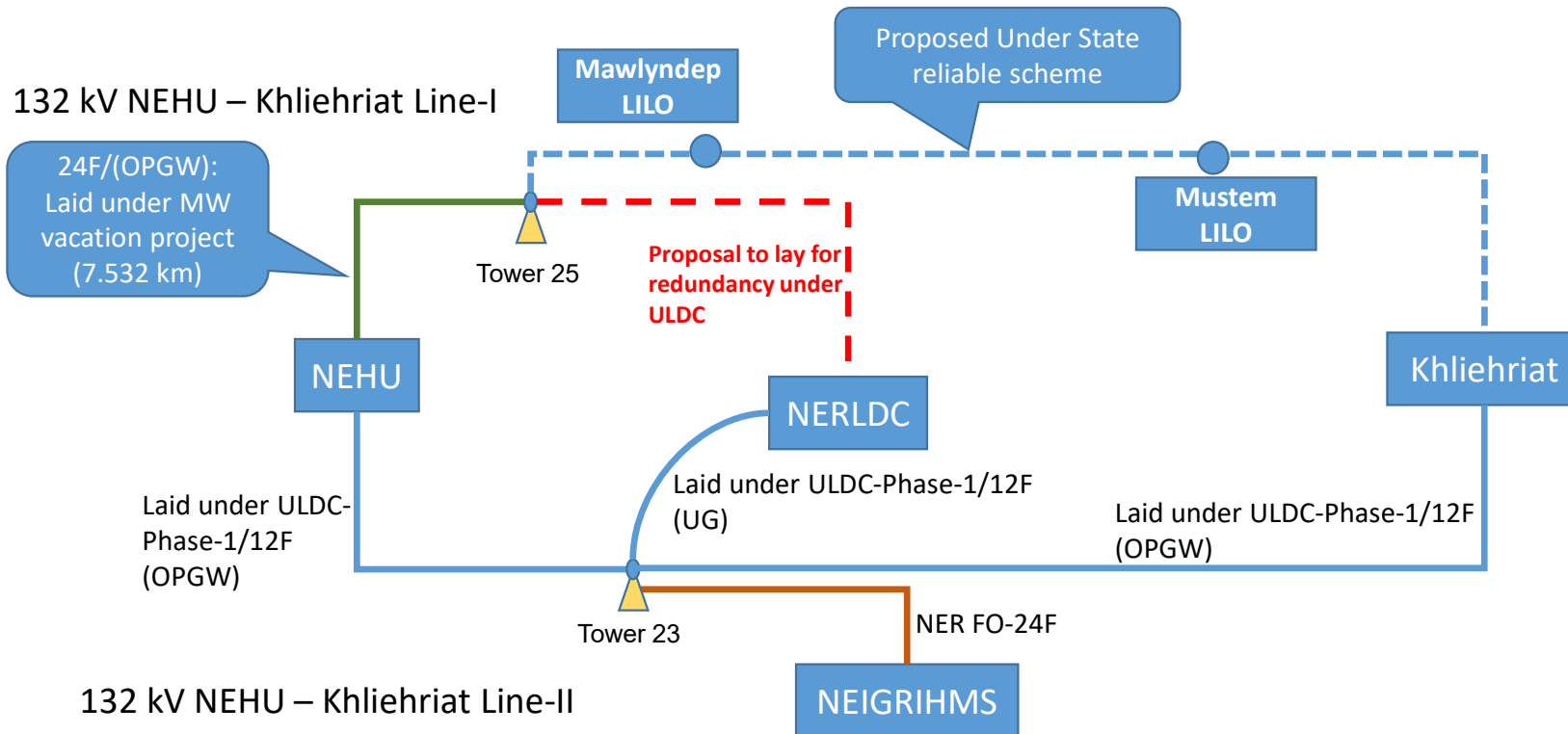

- NEHU to NEIGRIHMS (9 km) – approved under NER FO Expansion project.
 - Partly laid between NEIGRIHMS to Tower 23 i.e. 1.8 km at present.
- “Tower 23” to NERLDC underground 24 fibres of already approved in Reliable Communication Scheme of POWERGRID

NEHU-NEGRHIMS Redundancy

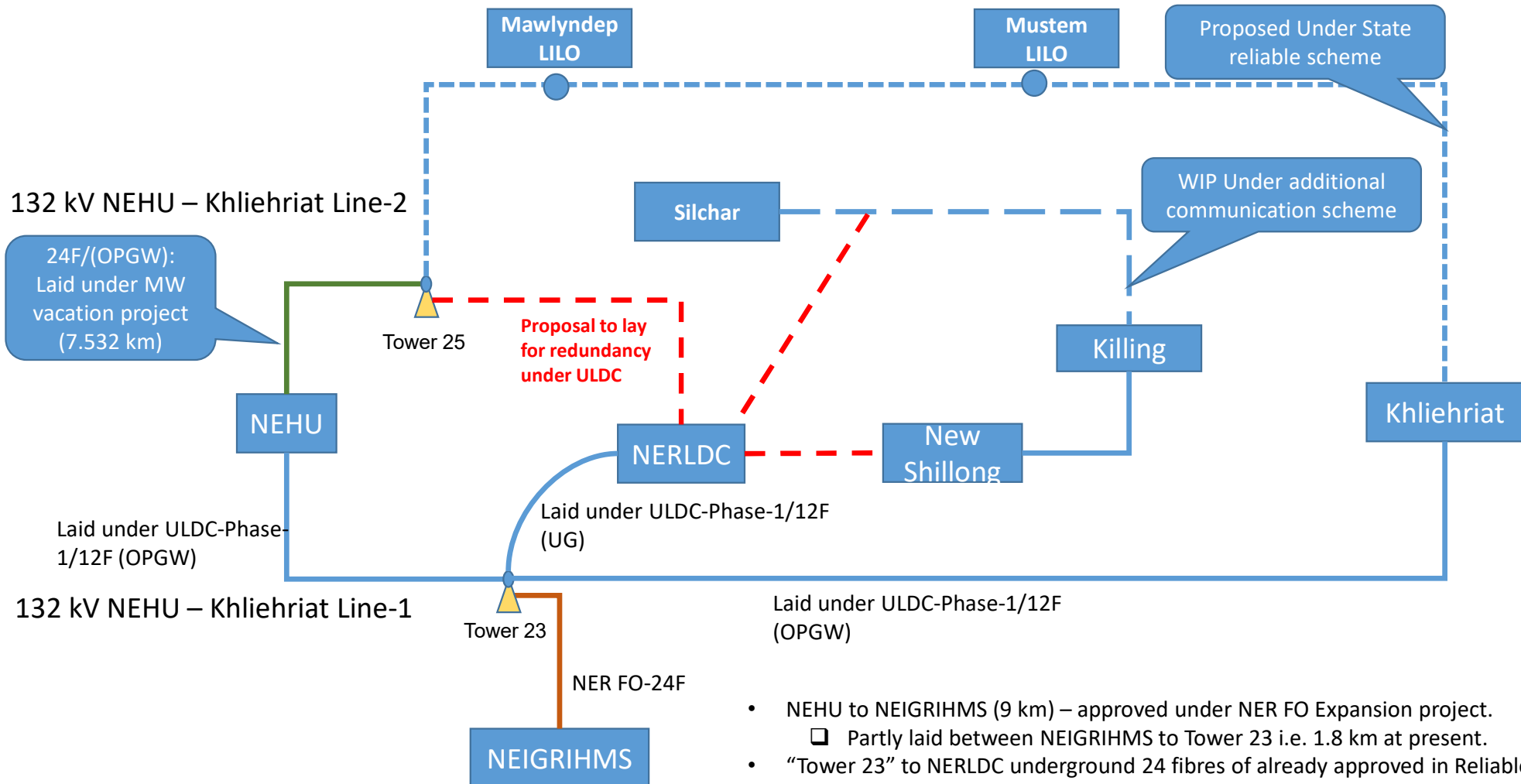

- NEHU to NEGRHIMS (9 km) – approved under NER FO Expansion project.
 - Partly laid between NEGRHIMS to Tower 23 i.e. 1.8 km at present.
- “Tower 23” to NERLDC underground 24 fibres of already approved in Reliable Communication Scheme of POWERGRID

Solution for 132 kV NEHU – Khliehriat Line-I

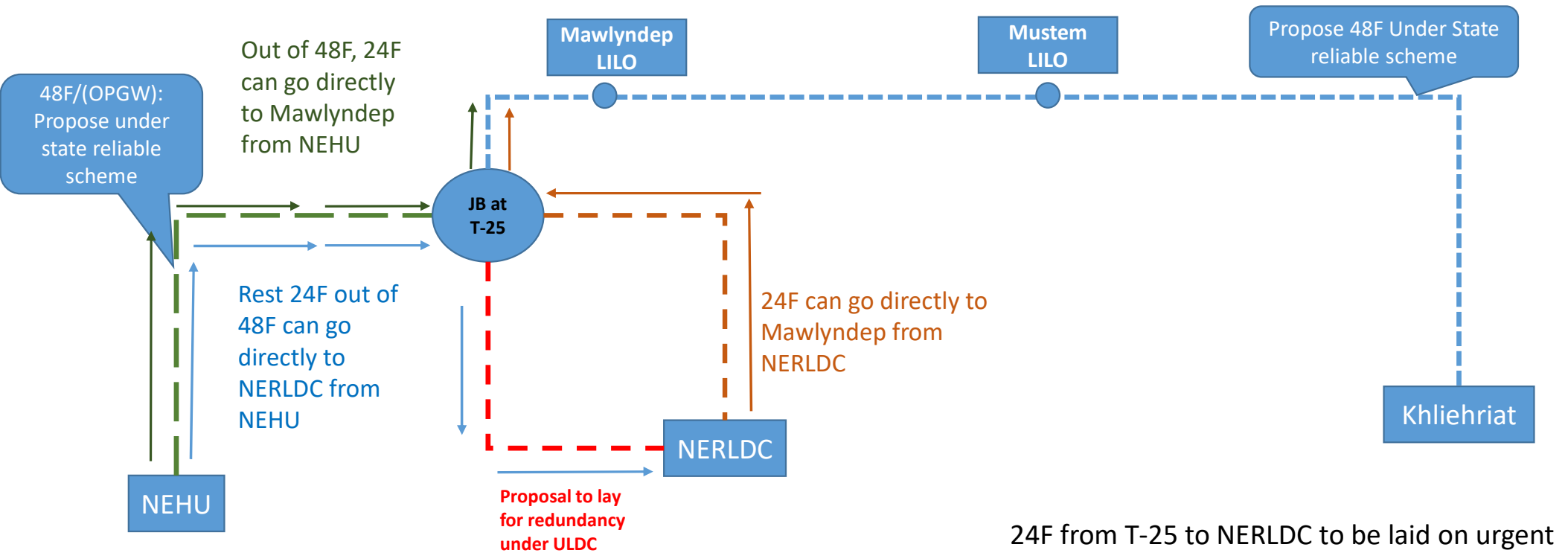

- Need to decap existing 7.532 KMs of OPGW laid by PGCIL

- - - - 24F from T-25 to NERLDC to be laid on urgent basis by ULDC-POWERGRID as decided in 25th NETeST meeting. This will be connected to NEHU as interim basis using NER-MW vacation OPGW

- - - - Additional 24F from T-25 to NERLDC which will be connected to Mawlyndep-Mustem-Khliehriat

Solution for 132 kV NEHU – Khliehriat Line-I (in table)

Sl. No.	From	To	Number of Fiber
1	NEHU	NERLDC	24F
2	NEHU	Mawlyndep	24F
3	NERLDC	Mawlyndep	24F
4	Mawlyndep	Mustem-Khleiriat	48F

Solution for 132 kV NEHU – Khliehriat Line-II

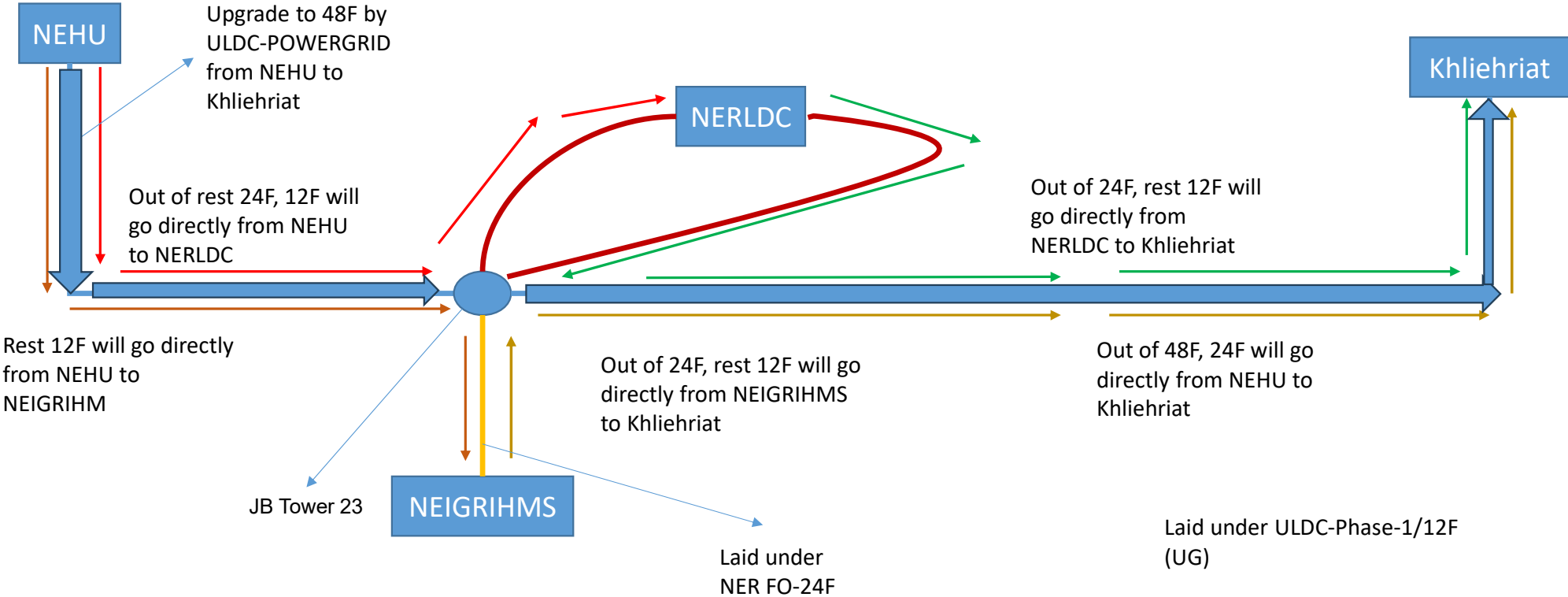

Solution for 132 kV NEHU – Khliehriat Line-II (in table)

Sl. No.	From	To	Number of Fiber
1	NEHU	Khliehriat	24F
2	NEHU	NERLDC	12F
3	NERLDC	Khliehriat	24F
4	NEHU	NEIGRHIMS	12F
5	NEIGRHIMS	Khliehriat	12F

Urgent Request of NERLDC

- Lay 48F Under ground fiber from T-25 of 132kV NEHU-Mawlyndep-Mustem-Khliehriat-2 to NERLDC.
- Connect 24F from NEHU to NERLDC over 132kV NEHU-Mawlyndep-Mustem-Khliehriat-2 to NERLDC.
- Above arrangements should be done as interim basis till MePTCL lay 48F from T-25 to Mawlyndep-Mustem-Khleihriat and NEHU to T-25.
- Decapitalisation of 7.532 KMs 24F-OPGW from NEHU to T-25 to be after project execution phase.

Thank you

A photograph of a server rack with various network equipment and cables. The cables are plugged into ports on the front of the server units. The background is slightly blurred, focusing on the equipment in the foreground.

28th NETeST Meeting - State-wise SAMAST Implementation Status

14 May 2024

Agenda

- **Assam SAMAST status**
- **Meghalaya SAMAST status**
- **Arunachal Pradesh SAMAST status**
- **Manipur SAMAST status**
- **Mizoram SAMAST status**
- **Nagaland SAMAST status**
- **Tripura SAMAST status**

Assam SAMAST status



Timelines	<ul style="list-style-type: none"> • Completion of milestone approval received on 10 Nov 2021 	<ul style="list-style-type: none"> • Completion of milestone approval received on 8 March 2022 	<ul style="list-style-type: none"> • Completion of milestone approval received on 6 Oct 2022 	<ul style="list-style-type: none"> • Completion of milestone approval received on 23 Mar 2023 	<ul style="list-style-type: none"> • Go-live of SAMAST modules completed on 30 June 2023 • Warranty support phase in progress and will end on 30 June 2024
Invoicing & payment status	<p>Total invoicing – INR 5,31,00,000/- (100% of the Contract value). Payment received – INR 4,37,48,883/-(82% of Contract Value)</p> <ul style="list-style-type: none"> • Milestone #1 (10% of contract value). Payment received • Milestone #2 (30% of contract value). Part-payment made. Balance pending INR 40,41,117/- Aging is 790+ days. • Milestone #3 (30% of contract value) - Payment received • Milestone #4 (20% of contract value)- Payment received • Milestone #5 (10% of contract value) invoice submitted. Amount pending INR 5310000/- Aging is 250+ days 				
Key issues to discuss	<ul style="list-style-type: none"> • Pending payment of INR 93,51,117/- • AEGCL to provide necessary documentation for the balance 16% fund from PSDF • Discussion regarding ATS as warranty support phase is expiring on 30 June 2024. 				

Meghalaya SAMAST status



Timelines	<ul style="list-style-type: none"> Completion of milestone approval received on 17 Dec 2021 	<ul style="list-style-type: none"> Completion of milestone approval received on 14 March 2022 	<ul style="list-style-type: none"> Completion of milestone approval received on 25 Nov 2022 	<ul style="list-style-type: none"> Completion of milestone approval received on 29 March 2023 	<ul style="list-style-type: none"> Go-live of the SAMAST modules completed on 30 June 2023. Warranty support phase in progress and will end on 30 June 2024
Invoicing & payment status	<p>Total invoicing INR 5,31,00,000/- (100% of contract value). Payment received 4,77,90,000/- (90% of Contract Value)</p> <ul style="list-style-type: none"> Milestone #1(10% of contract value) - Payment received. Milestone #2 (30% of contract value) - Payment received. Milestone #3 (30% of contract value) - Payment received. Milestone #4 (20% of contract value) - Payment received. Milestone #5 (10% of contract value) invoice submitted. Amount pending INR 53,10,000/-. Aging is more than 250+ days 				
Key issues to discuss	<ul style="list-style-type: none"> Milestone # 5 invoice amount INR 53,10,000/- pending. Discussion regarding ATS as warranty support phase is expiring on 30 June 2024. 				

Arunachal Pradesh SAMAST status

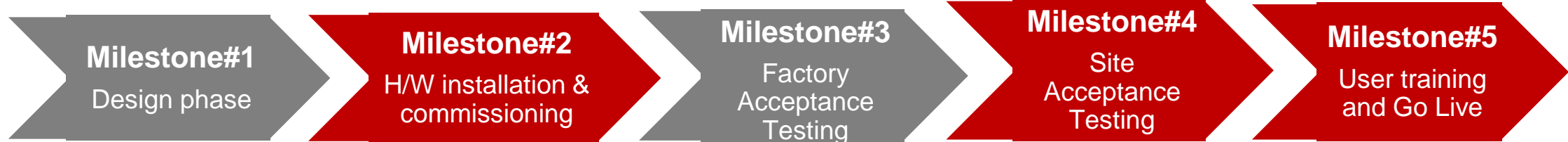

<p>Timelines</p>	<ul style="list-style-type: none"> • Completion of milestone approval received on 21 Jun 2022 	<ul style="list-style-type: none"> • Supply ,installation and commissioning of IT hardware items has been completed • Waiting for milestone#2 completion letter 	<ul style="list-style-type: none"> • Completion of milestone approval received on 22 Mar 2023 	<ul style="list-style-type: none"> • SAT of CMS module completed on 25 April 2024. SAT of the remaining SAMAST modules is in progress 	
<p>Invoicing & payment status</p>	<ul style="list-style-type: none"> • Total invoicing – INR 2,12,40,000/- (40% of the Contract value). • Milestone #1 (10% of contract value). Payment received • Milestone # 3 (30% of contract value). Partial Payment received INR 48,32,690 /- and remaining amount INR 1,10,97,310/- pending. Aging 190+ days. 				
<p>Key issues to discuss</p>	<ul style="list-style-type: none"> • Pending payment of INR 1,10,97,310/- 				

Manipur SAMAST status

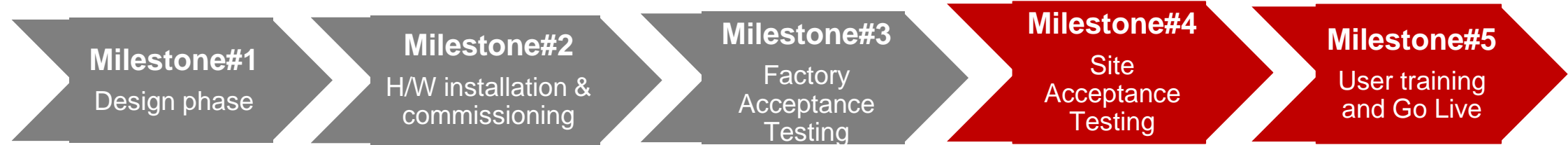

<p>Timelines</p>	<ul style="list-style-type: none"> Completion of milestone approval received on 23 May 2022 	<ul style="list-style-type: none"> Completion of milestone approval received on 20 March 2023 	<ul style="list-style-type: none"> Completion of milestone approval received on 6 January 2023 	<ul style="list-style-type: none"> SAT of Energy Scheduling, Open Access, Elogbook, CMS completed SAT for MDM, EA and MIS pending due to unavailability of significant AMR data 	
<p>Invoicing & payment status</p>	<p>Total invoicing INR 3,71,70,000/- (70% of Contract Value). Payment received - INR 3,71,70,000/- (70% of Contract Value)</p> <ul style="list-style-type: none"> Milestone#1 (10% of contract value) - Payment received Milestone# 3 (30% of contract value) - Payment received Milestone# 2 (30% of contract value) - Payment received 				
<p>Key issues to discuss</p>	<ul style="list-style-type: none"> SAT schedule is significantly impacted due to unavailability of AMR data. 				

Mizoram SAMAST status



<p>Timelines</p>	<ul style="list-style-type: none"> • Completion of milestone approval received on 15 March 2022. 	<ul style="list-style-type: none"> • Completion of milestone approval received on 24 March 2023 	<ul style="list-style-type: none"> • Completion of milestone approval received on 9 January 2023 	<ul style="list-style-type: none"> • Completion of milestone approval received on 5 March 2024 	<ul style="list-style-type: none"> • User training for all the modules completed on 18-21 March 2024 • SLDC to provide the Go-Live date of SAMAST modules.
<p>Invoicing & payment status</p>	<p>Total invoicing INR 3,71,70,000/- (70% of Contract Value). Payment received - INR 1,58,84,306/- (30% of Contract Value)</p> <ul style="list-style-type: none"> • Milestone#1 (10% of contract value) payment received. • Milestone # 3 (30% of contract value) – Part payment made. Balance pending INR 53,55,694/- Aging is 480+ days • Milestone# 2 (30% of contract value) invoice submitted. Amount pending INR 1,59,30,000/- Aging is 400+ days 				
<p>Key issues to discuss</p>	<ul style="list-style-type: none"> • Pending payments of INR 2,12,85,694/- . • Target go-live date. 				

Nagaland SAMAST status

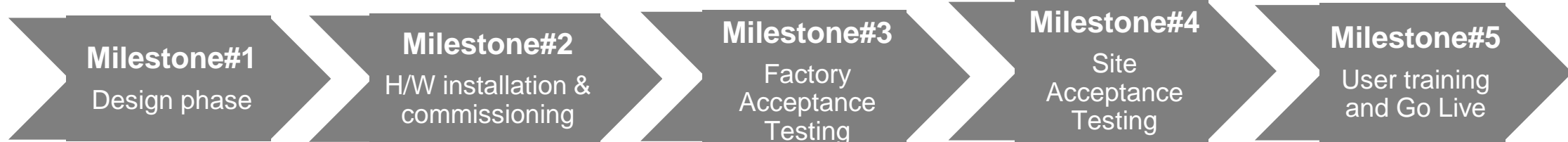

Timelines	<ul style="list-style-type: none"> • Completion of milestone approval received on 23 Jun 2022 	<ul style="list-style-type: none"> • Completion of milestone approval received from SLDC on 23 Mar 2023 	<ul style="list-style-type: none"> • Completion of milestone approval received on 14 Feb 2023 	<ul style="list-style-type: none"> • Completion of milestone approval received on 26 September 2023 	<ul style="list-style-type: none"> • Go-live of SAMAST modules completed on 12 February 2024 • Warranty support phase in progress
Invoicing & payment status	<p>Total invoicing INR 4,77,90,000/- (90% of contract value). Payment received 1,58,60,977/- (30 % of Contract Value)</p> <ul style="list-style-type: none"> • Milestone #1(10% of contract value) - Payment received. • Milestone #3 (30% of contract value. Part-payment made. Balance pending INR 53,79,023/-. Aging is 440+ days • Milestone# 2 (30% of contract value) invoice submitted. Amount pending INR 1,59,30,000/- . Aging is 360+ days • Milestone #4 (20% of contract value) invoice submitted. Amount pending INR 1,06,20,000/-. Aging is 200+ days 				
Key issues to discuss	<ul style="list-style-type: none"> • Pending payments of INR 3,19,29,023/- 				

Tripura SAMAST status

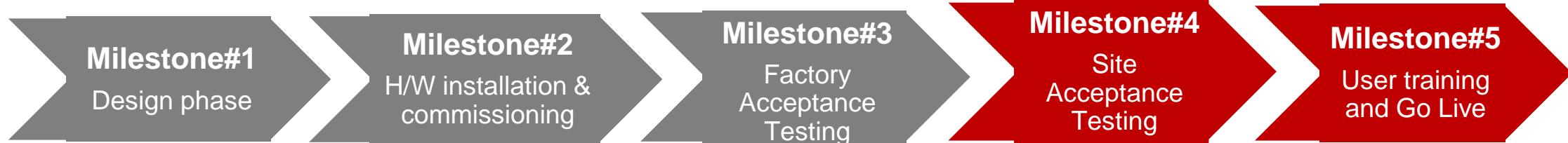

<p>Timelines</p>	<ul style="list-style-type: none"> • Completion of milestone approval received on 23 May 2022 	<ul style="list-style-type: none"> • Completion of milestone approval received on 04 December 2023 	<ul style="list-style-type: none"> • Completion of milestone approval received on 28 April 2023 	<ul style="list-style-type: none"> • SAT sign off completed for E-Logbook, CMS, and MDM on 28, 29 Nov 2023 and 28 Feb 2024 respectively. • SLDC to confirm the SAT dates of the remaining modules. 	
<p>Invoicing & payment status</p>	<ul style="list-style-type: none"> • Total invoicing INR 2,12,40,000/- (40% of Contract Value). Payment received -INR 1,52,05,767/- (~28.64% of Contract Value) • Milestone # 1 (10% of contract value) payment received • Milestone # 3 (30% of contract value). Partial Payment received INR 98,95,767.00/- and remaining amount INR 6,034,233/- pending. Aging is 370+ days 				
<p>Key issues to discuss</p>	<ul style="list-style-type: none"> • SCADA Data: Infrastructure related to connectivity to be arranged by SLDC. SCADA vendor has configured the required file in the intermediate server. • Pending Payment. 				

Thank you

[pwc.com](https://www.pwc.com)

© 2024 PwC. All rights reserved. Not for further distribution without the permission of PwC. “PwC” refers to the network of member firms of PricewaterhouseCoopers International Limited (PwCIL), or, as the context requires, individual member firms of the PwC network. Each member firm is a separate legal entity and does not act as agent of PwCIL or any other member firm. PwCIL does not provide any services to clients. PwCIL is not responsible or liable for the acts or omissions of any of its member firms nor can it control the exercise of their professional judgment or bind them in any way. No member firm is responsible or liable for the acts or omissions of any other member firm nor can it control the exercise of another member firm’s professional judgment or bind another member firm or PwCIL in any way.