



सत्यमेव जयते



भारत सरकार Government of India

विद्युत मंत्रालय Ministry of Power

उत्तर पूर्वी क्षेत्रीय विद्युत समिति

North Eastern Regional Power Committee

एन ई आर पी सी कॉम्प्लेक्स, डोंग पारमाओ, लापालाङ, शिल्लोंग-७९३००६, मेघालय
NERPC Complex, Dong Parmaw, Lapalang, Shillong - 793006, Meghalaya

SPEED POST/FAX

Ph : 0364-2534039

Fax: 0364-2534040

email: nerpc@ymail.com

website: www.nerpc.gov.in

No.: No. NERPC/SE (O)/PCC/2023/2599-2640

November 9, 2023

To

As per list attached

Sub: Minutes of 60th Protection Coordination Sub-Committee (PCC) Meeting

Sir/Madam,

Please find enclosed herewith the minutes of the 60th PCC Meeting held at "NERPC Conference Hall", Lapalang, Shillong on 31st October, 2023 for your kind information and necessary action. The minutes is also available on the website of NERPC: www.nerpc.gov.in.

Any comments/observations may kindly be communicated to NERPC Secretariat at the earliest.

Encl: As above

(एस. एम. आइमोल / S. M. Aimol)

निदेशक / Director

Distribution List:

1. Managing Director, AEGCL, Bijuli Bhawan, Guwahati – 781 001
2. Managing Director, APGCL, Bijuli Bhawan, Guwahati – 781 001
3. Managing Director, APDCL, Bijuli Bhawan, Guwahati – 781 001
4. Managing Director, MSPCL, Electricity Complex, Keishampat, Imphal – 795 001
5. Managing Director, MSPDCL, Secure Office Bldg. Complex, South Block, Imphal – 795 001
6. Director (Transmission), MePTCL, Lumjingshai, Short Round Road, Shillong – 793 001
7. Director (Generation), MePGCL, Lumjingshai, Short Round Road, Shillong – 793 001
8. Director (Distribution), MePDCL, Lumjingshai, Short Round Road, Shillong – 793 001
9. Director (Tech.), TSECL, Banamalipur, Agartala -799 001.
10. Director (Generation), TPGCL, Banamalipur, Agartala -799 001.
11. GM (Transmission), TPTL, Banamalipur, Agartala -799 001.
12. Chief Engineer (WE Zone), Department of Power, Govt. of Arunachal Pradesh, Itanagar- 791111
13. Chief Engineer (TP&MZ), Department of Power, Govt. of Arunachal Pradesh, Itanagar- 791111
14. Chief Engineer (Commercial) -cum- CEI, DoP, Govt. of Arunachal Pradesh, Itanagar- 791111
15. Engineer-in-Chief, P&E Department, Govt. of Mizoram, Aizawl – 796 001
16. Engineer-in-Chief, Department of Power, Govt. of Nagaland, Kohima – 797 001
17. ED (O&M), NEEPCO Ltd., Brookland Compound, Lower New Colony, Shillong-793003
18. ED (O&M), NHPC, NHPC Office Complex, Sector-33, Faridabad, Haryana-121003
19. Group GM, NTPC, Bongaigoan Thermal Power Project, P.O. Salakati, Kokrajhar- 783369
20. Vice President (Plant), OTPC, Badarghat Complex, Agartala, Tripura - 799014
21. ED, PGCIL/NERTS, Dongtiah-Lower Nongrah, Lapalang, Shillong -793 006
22. AGM (BD), NVVN, Core 5, 3rd floor, Scope Complex, 7 Institutional Area, Lodhi Rd., N. Delhi-3
23. Vice President, PTCIL, 2nd Floor, NBCC Tower, 15, Bhikaji Cama Place, New Delhi – 110066
24. Dy. COO, CTUIL, “Saudamini”, 1st Floor, Plot No. 2, Sector-29, Gurugram, Haryana – 122001
25. Chief Engineer, GM Division, Central Electricity Authority, New Delhi – 110066
26. Chief Engineer, NPC Division, Central Electricity Authority, New Delhi – 110066
27. Head & VP, (R&C), ENICL, IndiGrid, Windsor Building, Kalina, Santacruz (East), Mumbai- 98
28. ED, NERLDC, Dongtiah, Lower Nongrah, Lapalang, Shillong -793 006
29. CGM, AEGCL, Bijuli Bhawan, Guwahati – 781001
30. CGM, APGCL, Bijuli Bhawan, Guwahati – 781001
31. CGM, DISCOM, Bijuli Bhawan, Guwahati – 781001
32. Head of SLDC, Dept. of Power, Govt. of Arunachal Pradesh, Itanagar – 791111
33. CGM, (LDC), SLDC Complex, AEGCL, Kahilipara, Guwahati-781 019
34. Head of SLDC, MSPCL, Imphal – 795001
35. Head of SLDC, MePTCL, Lumjingshai, Short Round Road, Shillong – 793 001
36. Head of SLDC, P&E Deptt. Govt. of Mizoram, Aizawl – 796 001
37. Head of SLDC, Dept. of Power, Govt. of Nagaland, Dimapur – 797103
38. Head of SLDC, TSECL, Agartala – 799001
39. Chief Engineer (Elect), Loktak HEP, Vidyut Vihar, Kom Keirap, Manipur- 795124
40. DGM (O&M), OTPC, Badarghat Complex, Agartala, Tripura – 799014
41. Head, Transmission, KMTL, 7th Floor, Fulcrum, Sahar Road, Andheri (E), Mumbai-400099
42. Director, NETC, 2C, 3rdFloor, D21Corporate Park, DMRC Building Sector 21, Dwarka, Delhi-77.



(एस. एम. आइमोल / S. M. Aimol)

निदेशक / Director

North Eastern Regional Power Committee

Minutes of

60th Protection Coordination Sub-Committee Meeting

Date: 31/10/2023 (Tuesday)

Time: 10:00 hrs

Venue: NERPC Conference Hall, Shillong

The list of participants is at Annexure-I

Member Secretary welcomed all participants. He informed that NPC, CEA has finalized SoP for addressing GD/GI/tripping's and one of important provisions envisaged in SoP is to form a Power System Analysis Group (PSAG) in each region. The PSAG would study and analyses the major grid disturbance, Grid incidence in the region and would be comprise of members from RPC, NLDC, RLDC, PGCIL, a Protection Expert from the region (Academics or industry) and the Entity under whose jurisdiction GD/GI occurred. He also stated that NERPC Secretariat has prepared a Protection protocol in compliance with IEGC 2023 and requested all the constituents to provide comments on it at the earliest.

He also highlighted that utilities should carry out protection audits, internal as well as third party, in accordance with provisions of IEGC 2023 on their own. Third party audits may be conducted by a team constituted by NERPC for only select substations based on the criticality, analysis and requirement.

He then requested Director, NERPC to take up the agenda items.

C O N F I R M A T I O N O F M I N U T E S

1. CONFIRMATION OF MINUTES OF THE 59th PROTECTION SUB-COMMITTEE MEETING OF NERPC.

Minutes of the 59th PCC Meeting held on 29th August, 2023 (Tuesday) at NERPC Conference Hall, Shillong was circulated vide no. No.: NERPC/SE (O)/PCC/2023/2083-2124 dated 29th September, 2023.

No comment(s)/observation(s) were received from the constituents.

The Sub-committee confirmed the minutes of 59th PCCM of NERPC

B. ITEMS FOR DISCUSSION**B.1 Protection Audit of NER:**

First phase of Third-Party protection Audit (2013-14) was completed in 2015 and in Second Stage of Protection Audit (2017-18) numerous stations were covered. However, few stations are yet to be audited. Status for second phase of Protection Audit:

Name of the state/utility	Name of the station(s)/Status
Arunachal Pradesh	132/33kV Along, 132/33kV Pasighat, 220/132/33kV Deomali, 132/33kV Daporizo, 132/33kV Lekhi, 132/33kV Tippi, 132/33kV Chimpu, 132/33kV Khupi.
Assam	Completed in Nov'21.
Manipur	Yet to be intimated, i.r.o some Substations
Meghalaya	400/220/132kV Byrnihat, 132kV Mawphlang, 132KV Mustem, 132kV Umiam
Mizoram	Yet to be intimated, i.r.o some Substations
Nagaland	132kV Wokha, 132kV Sanis, 132kV Kiphire
Tripura	Yet to be intimated, i.r.o some Substations

In 58th PCCM, the sub-committee agreed to complete the audit of the remaining substations at the earliest. The sub-committee agreed that the audit of the substations could be done by the utilities themselves via any expert third party or by the third party as nominated by the sub-committee. If the audit had been done by the utility itself via any expert third party, then the report should be sent to NERPC and NERLDC. The forum decided to maintain a yearly record of the substations that had been audited.

In 59th PCCM following decision were taken -

- (a) The audit formats will be circulated to the nodal officers 2 weeks prior to the date of audit and the nodal officers of respective State/power utilities have to fill the format and submit to the NERPC secretariat within 1 week.
- (b) The final audit report will be completed within 2 weeks after the completion of Audit.
- (c) The forum decided that the SOP as issued by NPC, CEA will be followed for the third-party protection audit to be carried out by NERPC

NPC division of CEA has finalized S.O.P for third party protection Audit. (**Annexure-B.1.1**).

NERPC has prepared revised calendar for third party protection audit for reference of the constituents. (**Annexure-B.1.2**)

Deliberation of the sub-committee

Third party audit format was circulated by NERPC to constituents. The forum suggested that Tie-breaker status and Bus -coupler status may also be included in the audit format (Audit Format attached **Annexure B.1.3**).

The audit formats will be circulated to the nodal officers 2 weeks prior to the date of audit and the nodal officers of respective State/power utilities have to fill the format and submit to the NERPC secretariat within 1 week.

Member Secretary NERPC informed that third party protection audit has to be generally conducted by the utilities on their own however the 3rd party audit will be carried out by team constituted by NERPC at selected substations based on the criticality, analysis and requirement.

Audit of Kohima, Wokha, Sanis, Chepouzou, Mokokchung and Dimapur Substations of Nagaland will tentatively be scheduled from date 20th – 24th Nov'23. Audit of Sonabil, Agia, Sarusajai, Samaguri & BTPS Substations of Assam will be tentatively from dates 15th – 20th Dec, 2023.

The forum decided that compliance to audit reports will be followed up regularly in PCC meeting of NERPC. NERLDC to submit a list of all 132 kV and above substations of the States to NERPC.

Information regarding substations that have already been audited will be provided by states to NERPC & NERLDC.

AEGCL requested for a uniform guideline for maintenance of bay elements. Member Secretary requested POWERGRID to share their maintenance guideline with the states so that Assam and other utilities may adopt it after customizing to suit local requirement. POWERGRID agreed to make a ppt presentation in next PCCM on their maintenance procedure/guidelines for benefit of all members.

Sub-committee noted as above

B.2 Protection audit and protection performance indices as per IEGC 2023

As per the protection code of IEGC 2023 following roles and responsibilities, related to the subject mentioned, of constituents have been defined–

Description		Constituent	Responsibility	Timeline
Audit	Internal Audit	All users (132kV and above)	Shall conduct internal audit of protection system	Annually
			Audit report to be shared with RPC	Not specified
			Action plan for rectification of deficiencies to be shared with RPC	Not specified
	Third party Audit	All users (132kV and above)	Shall conduct audit for each SS	Once in five years
			Shall conduct audit on advice of RPC	Within three months of advice of RPC
			Audit report* to be submitted to RPC and NERLDC/SLDC	Within a month of submission of third-party audit report
			Action plan for rectification of deficiencies	Same as above
			RPC	Compliance to audit reports to be followed up regularly
	RPC	After analysis of any event, shall identify substations where audit is required to be carried out	Conditional responsibility	
	Annual audit plan	All users	Annual audit plan to be submitted to RPC by 31st October	Annual
Performance indices **	1. Dependability index (D)	All users (132kV and above)	Shall submit the indices for previous month to RPC and RLDC	monthly
	2. Security index (S)	All users	Shall submit the reason for indices less than unity (element wise) and action plan for corrective measures	Not specified
	3. Reliability index (R)	RPC	Action plan to be regularly followed up in RPC	

*Audit report shall contain information sought in the format enclosed as **Annexure – B.2**

**definition of indices

<p>(a) The Dependability Index defined as $D = \frac{N_c}{N_c + N_f}$</p> <p>where,</p> <p>$N_c$ is the number of correct operations at internal power system faults and</p> <p>N_f is the number of failures to operate at internal power system faults.</p> <p>(b) The Security Index defined as $S = \frac{N_c}{N_c + N_u}$</p> <p>Where,</p> <p>$N_c$ is the number of correct operations at internal power system faults</p> <p>N_u is the number of unwanted operations.</p> <p>(c) The Reliability Index defined as $R = \frac{N_c}{N_c + N_i}$</p> <p>Where,</p> <p>$N_c$ is the number of correct operations at internal power system faults</p> <p>N_i is the number of incorrect operations and is the sum of N_f and N_u</p>

Deliberation of the sub-committee

Forum agreed that all users (132 kV and above) have to conduct Internal Audit annually and submit audit report to RPC with action plan for rectification of deficiencies within 30 days of Audit.

RLDC, after analysis of any event, will suggest NERPC for third party audit. Compliance to audit report given by third party will be followed up in every PCCM.

Member Secretary directed all the users to submit third party audit plan to NERPC before 15th November for FY 2024-25 and next year onwards, by 31st October as per IEGC 2023.

All users have to submit Performance indices (Dependability-D, Security-S, Reliability-R) to NERPC & NERLDC by 10th of every month for previous month indices. Users also have to submit reason for indices being less than unity and corrective action plan. Action plan will be regularly followed up in PCCM.

B.3 Standard Operating Procedure for addressing GD/GI/tripping

NPC, CEA has finalized the SOP to address Grid disturbance/Grid Incidents/other tripping in consultation with all RPCs. The same is attached as **Annexure B.3** and put up for deliberation of the sub-committee.

Deliberation of the sub-committee

NERPC highlighted the salient features of the SOP and informed that it is aligned with the IEGC 2023.

NERPC pointed out that as per SOP, a Protection System Analysis Group (PSAG) shall be constituted consisting of members from RPC, NLDC, RLDC, PGCIL, a Protection Expert from the region along with the Entity under whose jurisdiction GD/GI occurred to analyse the GD/GI in detail by visiting the respective substation(s) physically and conducting the meetings. PSAG would finalize the remedial actions and recommendations after deliberations and detail analysis. The progress of implementation of the PSAG shall be followed up in the PCC meetings.

Member Secretary, NERPC suggested that one Protection Expert could be from the academia or industry. He further requested to nominate members from concerned utilities at the earliest.

Forum approved the SOP. Forum also requested concerned utilities to send nominations for PSAG within 15 days.

B.4 Protection protocol and protection philosophy of NER

In compliance with clause 12(2) and clause 13 of IEGC 2023, NERPC has prepared draft protection protocol for NER. The same is attached as **Annexures B.4** and put up for deliberation of the sub-committee.

Deliberation of the sub-committee

Member Secretary, NERPC requested all the utilities, SLDCs and NERLDC to provide comments on the protocol within 15 days. The Protection Protocol would be finalised after incorporating comments/observations (if any) from the constituents. If inputs/comments are not received from constituents, the protocol as circulated by NERPC would be treated as final.

B.5 df/dt scheme

df/dt scheme is not available in NER. The necessity of the scheme for NER may be deliberated in the forum.

In 59th PCCM, the forum agreed on the necessity of implementing the df/dt scheme in NER, considering the growing presence of renewable energy sources in the country and consequently reducing inertia of the grid.

Member Secretary, NERPC directed NERLDC to prepare a plan for the implementation of the df/dt scheme in NER.

Deliberation of the sub-committee

NERLDC informed that the requirement of load quantum for NER and frequency set points will be determined after analysis based on NPC criteria.

Member Secretary stated that NPC is preparing plan for df/dt scheme, same will be further discussed and approved in upcoming NPC meeting. He further opined that funding for the df/dt scheme may be taken from PSDF.

The forum suggested that preliminary study has to be done by RLDC/SLDC on where df/dt scheme can be implemented in NER.

B.6 Analysis and Discussion on Major Grid Disturbances which occurred in NER grid w.e.f. August 2023 to September 2023:***August 2023*****Events related to Assam**

S N	Event	Discussion points	Deliberation of the sub-committee
1.	220 kV Samaguri-Jawaharnagar line tripped at 09:32 Hrs on 07.08.2023. (B/G: - Due to tripping of this element, Jawaharnagar area of Assam Power System got separated from the rest of NER Grid 220 kV Sarusajai-Jawaharnagar line was under planned shutdown)	Samaguri end As per DR no fault observed Mal operation of relay DT signal tripping CB operated in 45ms AR not attempted R=0.1kA, Y=0.099kA, B=0.1kA, JAWAHARNAGAR END DR not available	
2.	132 kV North Lakhimpur - Dhemaji line tripped at 08:39 Hrs on 08.08.2023. (B/G: - Due to tripping of this element, Dhemaji & Silapathar areas of Assam Power System got	DR not available	

	separated from the rest of NER Grid)		
3.	<p>220 kV Agia - Boko and 220 kV Azara - Boko lines tripped at 09:32 Hrs on 18.08.2023.</p> <p>(B/G: - Due to tripping of these elements, Boko area and Boko Solar Power Plant of Assam Power System were separated from the rest of NER Grid)</p>	<p>Agia end</p> <p>Suspected Vegetation fault</p> <p>DT received and CB operated in 1192ms, AR not attempted</p> <p>Fault Current B=1.17 kA, N=0.92 kA, Angle -20 Degree</p> <p>Z2, Z3 Started after 1161ms</p> <p>Tripped on DT signal</p> <p>Boko end</p> <p>B-N fault</p> <p>EF relay picked up and CB Operated in 974ms, AR not Attempted</p> <p>Fault Current B=1.09 kA, N=1.23kA</p> <p>Angle -17 Degree</p> <p>Azara end</p> <p>Suspected operation due to over reach</p> <p>TEF trip operated in 1032ms</p> <p>AR not attempted</p> <p>Fault Current B=0.83 kA, N=0.72 kA</p> <p>Angle -27 degrees</p>	
4.	<p>132 kV Rupai - Chapakhowa line tripped at 18:03 Hrs on 26.08.2023.</p> <p>(B/G: - Due to tripping of this element, Chapakhowa area of Assam Power System and Pasighat, Roing, Tezu, Namsai areas</p>	<p>Rupai End</p> <p>DR available not as per standard only one signal visible L1 86B OPTD</p> <p>Chapakhowa End</p> <p>B-N Fault</p> <p>Earth Fault (In>1) activated and operated in 50ms</p> <p>AR not attempted</p>	

	<p>of Arunachal Pradesh Power System got separated from the rest of NER Grid</p> <p>132 kV Along- Pasighat line was under emergency shutdown since 16:19 Hrs on 26.08.2023 due to tower collapse)</p>	<p>Current signal is not proper in DR so we cannot extract the value of current and Angle</p>	
5.	<p>132 kV Rupai - Chapakhowa line tripped at 09:14 Hrs on 29.08.2023.</p> <p>(B/G: - Due to tripping of this element, Chapakhowa area of Assam Power System and Basar, Along, Pasighat, Roing, Tezu, Namsai areas of Arunachal Pradesh Power System got separated from the rest of NER Grid</p> <p>132 kV Daporijo - Basar line was declared faulty since 05:13 Hrs on 27.08.2023)</p>	<p>DR available not submitted</p>	

Events related to Arunachal Pradesh

S N	Event	Discussion points	Deliberation of the sub-committee
1.	<p>132 kV Balipara - Tenga line tripped at 21:52 Hrs on 02.08.2023.</p> <p>(B/G: - Due to tripping of this element, Tenga, Khupi areas and Dikshi HEP of Arunachal Pradesh Power</p>	<p>Balipara end</p> <p>Y-N Fault</p> <p>Suspected Lightning Fault</p> <p>Z1 activated and CB Operated in 57ms</p> <p>AR not attempted</p> <p>Fault Y=3.9kA, N=3.6 kA</p>	

	System got separated from the rest of NER Grid)	<p>Angle -69 Degree</p> <p>Tenga END</p> <p>Z1 activated and CB Operated in 90ms</p> <p>AR not attempted</p> <p>Fault Current Y=0.54kA, N=0.78kA</p> <p>Angle -57 degree</p>	
2.	<p>132 kV Daporijo -Ziro and 132 kV Along - Pasighat lines tripped at 23:02 Hrs on 04.08.2023.</p> <p>(B/G: - Due to tripping of these elements, Daporizo, Basar & Along areas of Arunachal Pradesh Power System got separated from the rest of NER Grid)</p>	<p>Zero End</p> <p>B-N fault</p> <p>Suspected solid ground fault</p> <p>Earth Fault (In>1) activated and CB Operated in 65ms</p> <p>AR not Attempted</p> <p>Fault Current Y=0.3 kA, N=0.25 kA</p> <p>Angle -3 degree</p> <p>DR before fault not standard</p> <p>DAPORIZO END DR NOT AVAILABLE</p>	
3.	<p>132 kV Along-Pasighat, 132 kV Along-Basar and 132 kV Basar - Daporijo lines tripped at 13:18 Hrs on 08.08.2023.</p> <p>(B/G: - Due to tripping of these elements, Basar and Along areas of Arunachal Pradesh Power System were separated from the rest of NER Grid)</p>	<p>132 kV Along- Daporizo</p> <p>Along END</p> <p>B-N Fault</p> <p>Z1 operated in 55ms</p> <p>AR operated successfully after 1050ms</p> <p>Fault Current B=0.35kA, N=0.34kA</p> <p>Daporizo End DR not Available</p> <p>132 kV Along-Pasighat</p> <p>Along</p> <p>Z1 operated in 63ms</p> <p>Fault Current B=0.34 kA, N=0.37 kA</p> <p>Angle 129 degree</p>	

		Pasighat End DR not Available	
4.	132 kV Balipara - Tenga line tripped at 20:59 Hrs on 08.08.2023. (B/G: - Due to tripping of this element, Tenga, Khupi areas and Dikshi HEP of Arunachal Pradesh Power System got separated from the rest of NER Grid)	Balipara end Likely Vegetation Fault R-B-N fault Z1 Operated in 61ms AR not Attempted Fault Current R=1.97kA, B=2.38kA, N=1.24kA Tenga end CB operated in 41ms (relay not mentioned in DR) Fault Current R=0.62kA, B=0.86kA	
5.	132 kV Balipara - Tenga line tripped at 19:27 Hrs on 21.08.2023. (B/G: - Due to tripping of this element, Tenga, Khupi areas and Dikshi HEP of Arunachal Pradesh Power System got separated from the rest of NER Grid)	DR not submitted in wave form only .dat file submitted	

Events related to Meghalaya

S N	Event	Discussion points	Deliberation of the sub-committee
1.	132 kV EPIP II - New Umtru & 132 kV Umtru - New Umtru lines tripped at 16:47 Hrs on 03.08.2023. (b/g: - Due to tripping of these elements, New Umtru Generating Station of Meghalaya Power System got separated from the rest of NER Grid)	Already discussed in 59 th PCCM.	

Events related to Mizoram

S N	Event	Discussion points	Deliberation of the sub-committee
1.	132 kV Zuangtui -Serchip line tripped at 12:25 Hrs on 01.08.2023. (B/G: - Due to tripping of this element, Serchip, Lunglei, Melriat(MI) and Lungmual areas of Mizoram Power System got separated from the rest of NER Grid 132 kV Aizawl-Lungmual line was under planned shutdown from 07:54 Hrs on 01.08.2023)	Zuangtui End Likely a Vegetation fault R- N Fault Earth fault relay operated in 59ms AR not Attempted Fault Current R=0.55kA,N=0.32kA Angle -7.8 degree Serchip end DR not Available	
2.	132 kV Melriat(PG) - Zuangtui line tripped At 11:49 Hrs on 29.08.2023. (B/G :- Due to tripping of this element, Zuangtui, Saitual, Vankal, Serchhip, Lunglei and Khawzawl areas and Vankal Solar Power Plant of Mizoram Power System got separated from the rest of NER Grid 132 kV Melriat-Lunglei line was under shutdown to control overloading of 132kV Aizawl-Lungmual line).	Melriat END R-N Fault Earth Fault relay operated in 113 ms AR not attempted Fault Current R=1.07kA, N=0.8kA Angle -22 degree Zuangtui end No tripping	

Events related to Nagaland

S N	Event	Discussion points	Deliberation of the sub-committee
1.	132 kV Kohima-Meluri line tripped At 19:14 Hrs on 01.08.2023.	No DR submitted	

	(B/G: - Due to tripping of this element, Meluri, Kiphire areas and Likimro HEP of Nagaland Power System got separated from the rest of NER Grid)		
2.	132 kV Kohima-Meluri line tripped At 12:30 Hrs on 02.08.2023. (B/G: - Due to tripping of this element, Meluri, Kiphire areas and Likimro HEP of Nagaland Power System got separated from the rest of NER Grid)	No DR submitted	
3.	132 kV Dimapur (PG) - Dimapur (DoP, Nagaland) D/C lines tripped At 16:35 Hrs on 02.08.2023. (B/G: - Due to tripping of this element, Dimapur (NL) area of Nagaland Power System got separated from the rest of NER Grid)	<p>No DR submitted for CKT 1 CKT 2</p> <p>Dimapur (PG) end</p> <p>Likely a solid fault</p> <p>Z1 activated and operated in 72ms</p> <p>AR Operated successfully after 1676ms</p> <p>Fault Current Y=10.17kA, N=9.73kA, Angle -18 degree</p> <p>Dimapur (DoP, Nagaland)</p> <p>END</p> <p>Over current ($I > 1$) operated in 39ms</p> <p>DR is not standard so Angle and fault current cannot be extracted from DR.</p>	

4.	132 kV Kohima-Meluri line tripped At 18:51 Hrs on 18.08.2023. (B/G: - Due to tripping of this element, Meluri, Kiphire areas and Likimro HEP of Nagaland Power System got separated from the rest of NER Grid)	Kohima END Suspected vegetation fault B-N Fault Z1 operated in 78 ms AR not attempted Fault Current B=0.99kA, N=0.95kA Angle -55 degree Meluri end DR not standardised	
----	---	--	--

Deliberation of the sub-committee

The above item will be deliberated in the Subgroup meeting.

Agenda items from NERLDC

B.7 Submission of Flash Report and Detailed Report by User/SLDC as per 37.2 of IEGC-2023:

As per IEGC-2023, Event reporting by User as per 37.2

Event reporting shall make available adequate data to facilitate event analysis.

(a) Immediately following an event (grid disturbance or grid incidence as defined in the CEA Grid Standards) in the system, the concerned user or SLDC shall inform the RLDC through voice message.

(b) Written flash report shall be submitted to RLDC and SLDC by the concerned user within the time line specified in Table 8 below.

(c) Disturbance Recorder (DR), station Event Logger (EL), Data Acquisition System (DAS) shall be submitted within 24 Hrs specified in Table 8 below.

(d) RLDC shall report the event (grid disturbance or grid incidence) to CEA, RPC and all regional entities within twenty-four (24) hours of receipt of the flash report.

(e) After a complete analysis of the event, the user shall submit a detailed report in the case of grid disturbance or grid incidence within one (1) week of the occurrence of event to RLDC and RPC.

(f) RLDCs and NLDC (for events involving more than one region) shall prepare a draft report of each grid disturbance or grid incidence including simulation results and

analysis which shall be discussed and finalized at the Protection subcommittee of RPC.

TABLE 8 : REPORT SUBMISSION TIMELINE

Sr. No.	Grid Event [^] (Classification)	Flash report submission deadline (users/ SLDC)	Disturbance record and station event log submission deadline (users/ SLDC)	Detailed report and data submission deadline (users/ SLDC)	Draft report submission deadline (RLDC/ NLDC)	Discussion in protection committee meeting and final report submission deadline (RPC)
1	GI-1/GI-2	8 hours	24 hours	+7 days	+7 days	+60 days
2	Near miss event	8 hours	24 hours	+7 days	+7 days	+60 days
3	GD-1	8 hours	24 hours	+7 days	+7 days	+60 days
4	GD-2/GD-3	8 hours	24 hours	+7 days	+21 days	+60 days
5	GD-4/GD-5	8 hours	24 hours	+7 days	+30 days	+60 days

[^]The classification of Grid Disturbance (GD)/Grid Incident (GI) shall be as per the CEA Grid Standards.

All User/SLDCs are requested to prepare and share **Flash Report** and **Detailed Report** with NERLDC and NERPC following any Grid Events. (Format attached).

Deliberation of the sub-committee

After detailed deliberation, the forum strongly urged the utilities to provide reports and data as per the scheduled mentioned and IEGC 2023. Sr. GM, NERLDC emphasized on the importance of submission of DAS data following any grid event/generator tripping for post fault analysis purpose.

B.8 Submission of Protection Performance indices by Transmission Utilities:

As per Regulation No. 15(6), Protection Code - Users shall submit the following protection performance indices of previous month to their respective RPC and RLDC on monthly basis for 220 kV and above (132 kV and above in NER) system, which shall be reviewed by the RPC:

- The Dependability Index defined as $D = Nc / Nc + Nf$
- The Security Index defined as $S = Nc / Nc + Nu$
- The Reliability Index defined as $R = Nc / Nc + Ni$

Where,

Nc: number of correct operations at internal power system faults

Nf: Number of failures to operate at internal power system faults.

Nu: Number of unwanted operations.

Ni: Number of incorrect operations and is the sum of Nf and Nu

As per Regulation No. 15(7), each user shall also submit the reasons for performance indices **less than unity** of individual element wise protection system to the respective RPC and action plan for corrective measures. The action plan will be followed up regularly in the respective RPC.

As per the above quoted regulations, **all the Users** are requested to furnish performance indices with regards to the tripping and analysis of their respective elements during the previous month to **NERLDC and NERPC by 10th of every month** such that it can be verified by NERLDC.

Deliberation of the sub-committee

Refer to discussion in agenda B.2

B.9 Status of submission of FIR and DR & EL outputs for the Grid Events as on dated 19.10.2023

In line with regulation 12 (1) of CEA Grid Standards Regulations and IEGC-23 provision under clause 37.2 (c), FIR and DR & EL Outputs for each grid events are required to be submitted by concerned utilities to NERLDC for detailed investigation and analysis.

Name of Utility	Total FIR/ DR/EL	Total FIR, DR & EL submitted			Total FIR, DR & EL not submitted			% Submission of		
		FIR	DR	EL	FIR	DR	EL	FIR	DR	EL
DoP, Arunachal Pradesh	47	31	18	24	16	23	21	66	48	54
DEPL	9	0	0	0	9	9	9	0	0	0
AEGCL	105	82	86	82	23	11	13	78	89	87
APGCL	8	0	0	0	8	8	8	0	0	0
MSPCL	39	27	3	4	12	33	34	69	15	13
MePTCL	17	14	16	16	3	1	1	82	94	94
MePGCL	16	0	2	0	16	10	16	0	29	0
P&ED, Mizoram	1	0	0	0	1	0	0	0	100	100
DoP, Nagaland	25	20	14	14	5	5	5	80	80	80
TSECL	38	20	26	29	18	7	7	53	81	82
TPGCL	8	0	0	0	8	8	8	0	0	0
POWERGRID	84	83	70	74	1	2	4	99	97	95
NEEPCO	80	39	36	28	41	40	49	49	47	36
NHPC	8	0	0	0	8	8	8	0	0	0
NTPC	2	0	0	0	2	2	2	0	0	0
ERTS	1	0	0	0	1	1	1	0	0	0
BHUTAN	1	0	0	0	1	1	1	0	0	0
OTPC	4	3	3	1	1	0	2	75	100	50
IndiGrid	16	15	15	15	1	1	1	94	94	94

Status of uploading of FIR and DR & EL outputs in Tripping Monitoring Portal for events from 30-08-2023 to 19-10-2023 is given below:

Concerned Utilities are requested to upload Disturbance Recorder (DR), Event Logger (EL) outputs for grid events along with a First Information Report (FIR) in Tripping Monitoring Portal (<https://tripping.nerltdc.in/Default.aspx>) for analysis purpose. In light of the cybersecurity measures implemented by Grid India to safeguard sensitive information, NERLDC has created the email address nerltdcso3@gmail.com. This new account has been specifically set up to facilitate the secure exchange of DR and EL files that have previously faced blockage when sent to nerltdcprotection@grid-india.in.

In 59th OCCM following points were discussed –

Concerned utilities updated as follow-

1. Assam- due to shifting related works at Boko and Mariani there have been shortcomings in submitting the required data.
2. Tripura- Non-availability of Laptops at substations and connectivity issues hampering the submission of DR/EL in timely manner.
3. Nagaland – some DRs are missing at the substations. SLDC will coordinate with substation to address the issue.
4. MePTCL – at some substations, relays are of Siemens make and some issues are being faced in downloading from the relays. Matter has been taken up with the OEM.
5. Mizoram- informed that they will upload DR/EL for intra-state lines also.

Member Secretary stated that all States/Utilities to take a step to resolve above shortcomings and send the DR/ER data (which is mandatory) as per IEGC regulation.

Deliberation of the sub-committee

Arunachal Pradesh stated that at some locations due to non-availability of Numerical Relays, DR/EL data could not be furnished. The forum requested DoP Arunachal Pradesh to replace the Electromechanical Relay with Numerical Relay in line with the CEA regulations. The forum suggested DOP, Arunachal Pradesh to regularly check the lines for vegetation infringement clearance.

Manipur intimated that DR/EL could not be uploaded due to continuous internet shutdown in the state due to prevailing law and order situation. Manipur further informed that whitelisting of Substation for internet connectivity already submitted to higher management.

MePTCL stated that issue related to Siemens make relays have now been resolved and DR/EL is now downloadable.

The forum asked all the utilities to submit a list of substations where numerical relay is not available and expedite the implementation of the same as stipulated under IEGC Regulation 2023.

Member Secretary stated that each entity should send the DR, EL, FIR in standard format. He also opined that State can take help of PSDF funding to replace all the mechanical relay with Numerical relay.

Forum suggested NERLDC to submit a tripping list based on tripping categories such as vegetation, lightning, etc. and requested constituents to try to reduce tripping of element.

Sub-committee noted as above

B.10 Non-Operation of A/R at Doyang HEP for 132 kV Dimapur- Doyang 1&2 line:

Sl. No.	Element Name	Time	Relay End1	Relay End2	Remarks
1	132 kV Dimapur - Doyang 1	19-09- 2023 14:53	DP, ZI, R-Y-E, FD: 86.192 Kms, AR Successful	DP, ZI, R-Y-E, AR Not Operated	Lightning
2	132 kV Dimapur - Doyang 2	07-08- 2023 19:35	DP, ZI, B-E, FD:23.84 kms, AR Successful	DP, ZI, B-E, AR Not Operated	Lightning
3	132 kV Dimapur - Doyang 2	19-08- 2023 02:19	DP, ZII, Y-E, FD: 91.14 Kms; carrier aided, AR Successful	DP, ZI, Y-E, AR Not Operated	Lightning

Numerous instances of tripping have been noted, primarily attributed to the transient nature of the fault. The Autorecloser at the Dimapur (PG) end has

consistently performed successfully. Nevertheless, it is apparent that no Autorecloser operation was recorded in the submitted Disturbance Recorder (DR) from the Doyang end, indicating that there is need of checking of Autorecloser function at Doyang HEP.

NEEPCO is requested to update the root cause and remedial measures taken so that line can be reclosed for transient fault.

Deliberation of the sub-committee

Based on the oral communication of NERLDC with NEEPCO official, NERLDC updated the forum that CBs at Doyang are spring closed and air operated (pneumatic type). As soon as breaker gets open, air pressure goes down below 15Kg/cm² and the breakers goes to non-operative mode. After running the compressor when air pressure is achieved to 15Kg/cm², that condition goes off, by that time AR time becomes over. They have called CGL, OEM of the breakers, to attend the problem. The OEM has assured that they will report within this month. In case, OEM is not able to resolve this matter, all the CBs of Doyang SY needs to be replaced (CBs were procured during commissioning of the Plant i.e., 2000).

Sub-committee noted as above

B.11 Non-operation of auto recloser in Important Grid Elements for transient faults w.e.f. September 2023:

Sl No	Element Name	Time	Relay End1	Relay End2	A/R not Operated	Remarks from Utility
1	132 kV Haflong - Umranshu Line	01-09-2023 01:21	DP, ZI, B-E, FD: 30.73 Kms AR successful	DP, ZI, B-E, FD: 17.1 kms	Umranshu	
2	400 kV Bongaigaon - Byrnihat Line	02-09-2023 11:36	DP, ZII, R-E, FD: 156.8 kms, AR successful	DP, ZI, R-E	Byrnihat	
3	400 kV Byrnihat - Silchar Line	10-09-2023 22:49	DP, ZI, Y-E, FD: 171.7Km, AR successful	DP, ZI, Y-E, FD: 152.23 Km	Silchar	

4	220 kV AGBPP - Mariani (AEGCL) Line	11-09- 2023 17:17	DP, ZI, Y-E	DP, ZI, Y- E, FD: 108.9 km (DR window – 1 second)	Both ends	
5	220 kV Agia - Boko Line	14-09- 2023 12:46	DP, ZI, B-E, FD: 44.7 Km	DP, ZII, B- E, FD: 36.5 Kms	Agia	
6	220 kV Agia - Boko Line	14-09- 2023 13:16	DP, ZI, B-E, FD: 44.7 kms	DP, ZII, B- E, FD: 15 km	Agia	
7	132 kV Badarpur - Karimganj Line	16-09- 2023 11:34	DP, ZI, R-Y, FD: 22.447kms	DP, ZI, R- Y, FD: 6.941 kms	Both ends	
8	220 kV Dimapur - Misa 2 Line	18-09- 2023 02:42	DP,ZI,R- E,FD: 1.45 km, AR successful	DP,ZII, R- E,FD:23kk m, Carrier Aided Tripping	Misa	
9	220 kV Agia - Azara Line	18-09- 2023 11:29	DP, ZII, B- E, Carrier Received, AR successful	DP, ZI, B-E	Azara	
10	132 kV BTPS - Dhaligaon 1 Line	18-09- 2023 16:43	DP, ZI, Y-B- E, FD: 20.6 kms	DP, ZI, Y- B-E	Both ends	
11	132 kV Bokajan - Dimapur Line	22-09- 2023 13:47	DP, ZI, B-E	DP, ZI, B- E, FD: 7.45 Kms, AR successful	Bokajan	
12	220 kV Agia - Boko Line	23-09- 2023 13:26	DP, ZI, B-E, FD: 27.8km AR not ready	DP, ZI, B- E, FD: 45.6km, operated	Agia	

13	220 kV Mariani (AEGCL) - Samaguri Line	29-09-2023 16:46	DP, ZI, B-E	DP, ZI, B-E, FD: 55.2 Kms	Both ends	
14	220 kV Mariani (AEGCL) - Samaguri Line	30-09-2023 10:24	DP, ZI, B-E, FD:127Kms	DP, ZI, B-E, FD: 29.8 Kms	Both ends	
15	132 kV Aizawl - Kolasib Line	01-10-2023 17:27	DP, ZI, B-E, FD: 33.9Km	DP, ZI, B-E, FD: 35.02 Kms	Aizawl	
16	132 kV Gohpur - North Lakhimpur 1	02-10-2023 10:59	DP, ZI, B-E,FD:7.7 KM	DP, ZI, B-E,FD:78.8 KM	Both ends	
17	220 kV Mariani (AEGCL) - Samaguri Line	13-10-2023 01:02	R-ph, 118.4 KM	DP, ZI, R-E, 29.8 km	Both ends	

Deliberation of the sub-committee

Sl No	Element Name	Time	Relay End1	Relay End2	A/R not Operated	Remarks from Utility
1	132 kV Haflong - Umranshu Line	01-09-2023 01:21	DP, ZI, B-E, FD: 30.73 Kms AR successful	DP, ZI, B-E, FD: 17.1 kms	Umranshu (AEGCL)	Breaker spring issue, so breaker not operated. Waiting for spare parts. Currently, AEGCL is monitoring after every tripping. Matter to be resolved by November'23
2	400 kV Bongaigaon - Byrnihat Line	02-09-2023 11:36	DP, ZII, R-E, FD: 156.8 kms, AR successful	DP, ZI, R-E	Byrnihat (MePTCL)	As per Meghalaya AR operated need to recheck and resolve the issue.

3	400 kV Byrnihat - Silchar Line	10-09- 2023 22:49	DP, ZI, Y-E, FD: 171.7Km, AR successful	DP, ZI, Y- E, FD: 152.23 Km	Silchar (NERTS)	Due to some configuration issue in the BCU breaker went under Lockout condition. Investigation underway. Will take help of GE and Resolve the issue.
4	220 kV AGBPP - Mariani (AEGCL) Line	11-09- 2023 17:17	DP, ZI, Y-E	DP, ZI, Y- E, FD: 108.9 km (DR window – 1 second)	Both ends	AR kept off for PID checking. Now in operation
5	220 kV Agia - Boko Line	14-09- 2023 12:46	DP, ZI, B-E, FD: 44.7 Km	DP, ZII, B- E, FD: 36.5 Kms	Agia	A/R issues due to B-pole closing timing issue at Agia. It will be checked in the coming planned S/D
6	220 kV Agia - Boko Line	14-09- 2023 13:16	DP, ZI, B-E, FD: 44.7 kms	DP, ZII, B- E, FD: 15 km	Agia	Same as 5 th
7	132 kV Badarpur - Karimganj Line	16-09- 2023 11:34	DP, ZI, R-Y, FD: 22.447kms	DP, ZI, R- Y, FD: 6.941 kms	Both ends	AR is not present at Karimganj (ZIV relay) which will be implemented within 2-3 months.
8	220 kV Dimapur - Misa 2 Line	18-09- 2023 02:42	DP,ZI,R- E,FD: 1.45 km, AR successful	DP,ZII, R- E,FD:23kk m, Carrier Aided Tripping	Misa	Relay configuration issue. Rectified
9	220 kV Agia - Azara Line	18-09- 2023 11:29	DP, ZII, B- E, Carrier Received, AR successful	DP, ZI, B-E	Azara	Goose communication issue with Relay. AEGCL informed that main-2 relay (REL 670) was not

						working which was replaced with Siemens make relay for temporary basis. It will be resolved in 2 months
10	132 kV BTPS - Dhaligaon 1 Line	18-09- 2023 16:43	DP, ZI, Y-B- E, FD: 20.6 kms	DP, ZI, Y- B-E	Both ends	PLCC fault due to battery issue. Now Resolved
11	132 kV Bokajan - Dimapur Line	22-09- 2023 13:47	DP, ZI, B-E	DP, ZI, B- E, FD: 7.45 Kms, AR successful	Bokajan	AR configured in the relay. However, need to check logic in next SD
12	220 kV Agia - Boko Line	23-09- 2023 13:26	DP, ZI, B-E, FD: 27.8km AR not ready	DP, ZI, B- E, FD: 45.6km, operated	Agia	Same as 5 th
13	220 kV Mariani (AEGCL) - Samaguri Line	29-09- 2023 16:46	DP, ZI, B-E	DP, ZI, B- E, FD: 55.2 Kms	Both ends (AEGCL)	AR ok at Samaguri. At Mariani Mariani panels being replaced. AR will be enabled by December end
14	220 kV Mariani (AEGCL) - Samaguri Line	30-09- 2023 10:24	DP, ZI, B-E, FD:127Kms	DP, ZI, B- E, FD: 29.8 Kms	Both ends	Same as point 13 th
15	132 kV Aizawl - Kolasib Line	01-10- 2023 17:27	DP, ZI, B-E, FD: 33.9Km	DP, ZI, B- E, FD: 35.02 Kms	Aizawl	AR block due to Carrier switch failure. It has been rectified.
16	132 kV Gohpur - North Lakhimpur 1	02-10- 2023 10:59	DP, ZI, B- E,FD:7.7 KM	DP, ZI, B- E,FD:78.8 KM	Both ends	AR logic issue. Need to change logic for 3-ph AR, currently 1-ph. Logic to be changed by November'23

17	220 kV Mariani (AEGCL) - Samaguri Line	13-10- 2023 01:02	R-ph, 118.4 KM	DP, ZI, R- E, 29.8 km	Both ends	Same as discussed at point 13 th
----	--	-------------------------	-------------------	--------------------------	-----------	---

B.12 Non operation SPS at Monarchak on 15-09-2023:

Monarchak and Rabindranagar area of Tripura power system is connected with rest of the NER grid through 132 kV Monarchak – Udaipur and 132 kV Monarchak – Rokhia line.

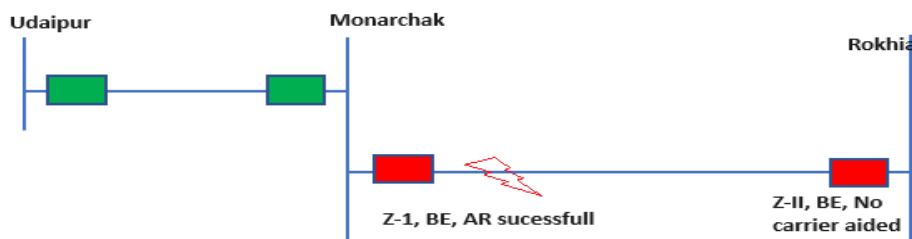

At 13:08 Hrs on 15-Sept-2023, 132 kV Monarchak - Rokhia Line tripped on DP with following relay indications- **Monarchak:** B-Ph, ZI, FD: 07.86 km, AR Successful, **Rokhia:** B-Ph, ZII, FD: 28.95 km. Non- operation of SPS at Monarchak is observed due to Successful autorecloser at Monarchak.

In the above event, Monarchak survived N-1 contingency as actual generation was 94 MW only otherwise blackout of Moanrchak is unavoidable.

Followings actions are requested from **TPGCL** and **NEEPCO**:-

- **NEEPCO** is requested to disable A/R operation at Monarchak for Udaipur and Rokhia line as a short-term measure to avoid blackout of Monarchak power station until implementation of PLCC/OPGW link by TSECL.
- **TPGCL & TSECL** is requested for early implementation/commissioning of PLCC link for successful operation of A/R scheme during transient fault at Rokhia and Udaipur. This will allow the changes in SPS at Monarchak :

a) Any one CB of either 132 kV Udaipur and Rokhia tripped at Monarchak Station and Gen>65 MW

b) A/R successful at Monarchak but CB tripped at Rokhia/Udaipur and Gen>65 MW

Following new revised scheme proposed for review and further implementation.

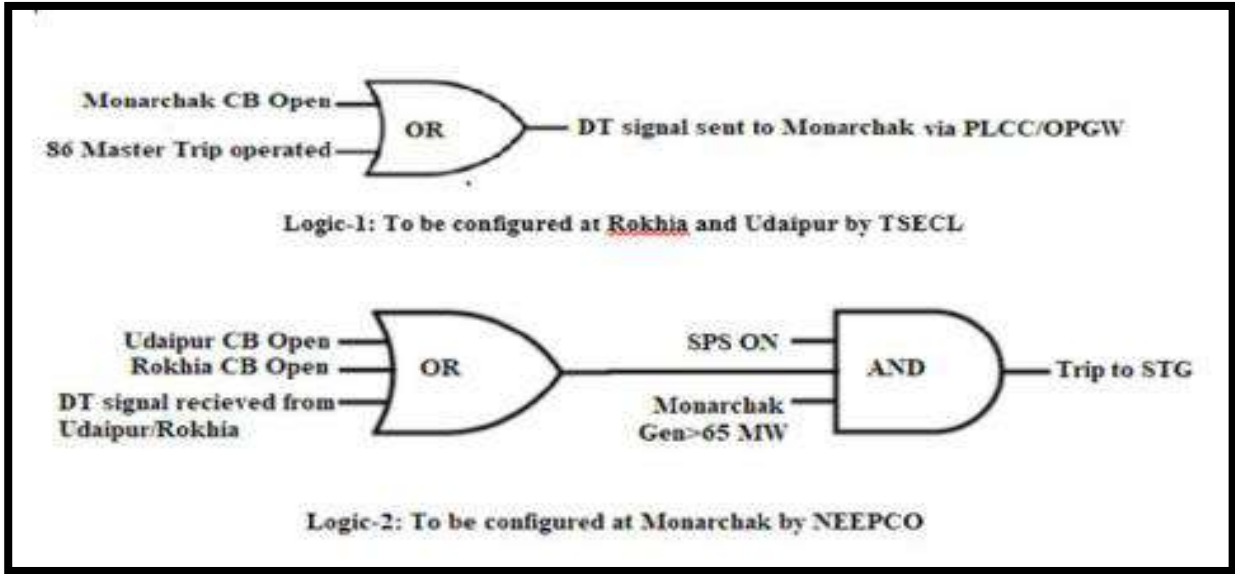

Deliberation of the sub-committee

1. Forum exhorted TPTL for commissioning of PLCC on the Monarchak-Rokhia and Monarchak-Udaipur lines at the earliest.
2. Forum requested NEEPCO to disable the AR at Monarchak till the commissioning of PLCC.

B.13 Details of tripping of lines due to spurious DT signal transmission:

Sl. No	Element Name	Outage Date and Time	DT Sent from	Root cause and remedial measures
1	400 kV Balipara - Kameng 1 Line	18-09-2023 15:46	Kameng HEP	DT sent from Kameng: DC circuit fault
2	132 kV Agartala - Bodhjannagar	28-09-2023 09:11	Agartala (TSECL)	
3	132 kV Haflong - Jiribam Line	07-10-2023 22:25	Jiribam (PGCIL)	
4	132 kV AGTCCPP - PK Bari (TSECL) 1 Line	11-10-2023 18:03	PK Bari(TSECL)	
5	132 kV AGTCCPP - PK Bari (TSECL) 2 Line	11-10-2023 18:03	PK Bari(TSECL)	

Utilities are requested to share the **root cause and remedial measures** taken.

Deliberation of the sub-committee

Sl. No	Element Name	Outage Date and Time	DT Sent from	Root cause and remedial measures
1	400 kV Balipara - Kameng 1 Line	18-09-2023 15:46	Kameng HEP	DT sent from Kameng: DC circuit fault Utility (NEEPCO) to send Action taken report
2	132 kV Agartala - Bodhjannagar	28-09-2023 09:11	Agartala (TSECL)	Absent
3	132 kV Haflong - Jiribam Line	07-10-2023 22:25	Jiribam (PGCIL)	DT sent from Jiribam due to DT control circuit cable issue. POWERGRID informed that the issue has been rectified.
4	132 kV AGTCCPP - PK Bari (TSECL) 1 Line	11-10-2023 18:03	PK Bari (TSECL)	Absent
5	132 kV AGTCCPP - PK Bari (TSECL) 2 Line	11-10-2023 18:03	PK Bari (TSECL)	Absent

Some utilities highlighted that one major issue with DT signaling is that DT signal gets activated on Noise voltage Pick up, which then generates spurious DT signal. NERTS stated that some modification in DT logic may be done to address the issue. Forum requested NERTS to share the logic with the utilities.

Subcommittee noted as above.

B.14 Blackout of Karong S/S of Manipur on 10-10-2023:

Blackout of Karong S/S occurred due to tripping of 132 kV Imphal – Karong Line & 132 kV Karong – Kohima Line at 12:21 Hrs of 10-10-2023.

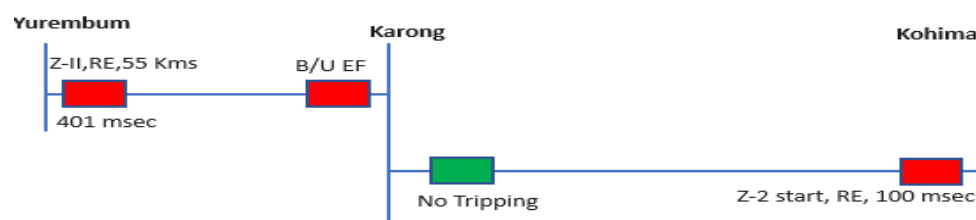

As per analysis from Yurembum & Kohima DR: Following were observed-

1. RE fault detected from Yurembum at a distance of 55.09 Kms from Yurembum and it was cleared within 401 msec.
2. Z-II, RE fault detected from Kohima at a distance of 42 Kms from Kohima. No tripping was observed from DR signature. Fault current disappear within 100 msec.
3. **Proper analysis** could not be done due to non submission of DR/EL from Karong by MSPCL.

MSPCL is requested to intimate the root cause for the event.

DoP, Nagaland is requested to intimate the reason of tripping from Kohima within in 100 msec.

Deliberation of the sub-committee

MSPCL informed that some accident happened in the sub-station area. The same could not be timely intimated to NERLDC due to suspension of internet data connectivity in Manipur. Also, DR/EL of Karong could not be submitted due to no internet connectivity in Karong area. Manipur informed whitelisting of some of the contacts of Karong substation personnels will be done to facilitate timely submission of DR/EL of Karong.

Nagaland stated that relay settings are ok, however mal-operation could be due to phase angle mismatch, need to check both end phase angle once situation normalize in Manipur.

Nagaland was requested to share Main and Backup relay setting data with NERPC & NERLDC to check the relay setting issue. Forum requested Nagaland to disable B/U feature from main numerical relay as Standalone B/U protection is already available.

Subcommittee noted as above.

B.15 Grid Disturbance at Mohanpur on 29-Sept-2023:

Mohanpur area of Tripura system was connected with rest of NER grid through 132 kV Mohanpur-Dhalabil and 132 kV Mohanpur-Agartala Line.

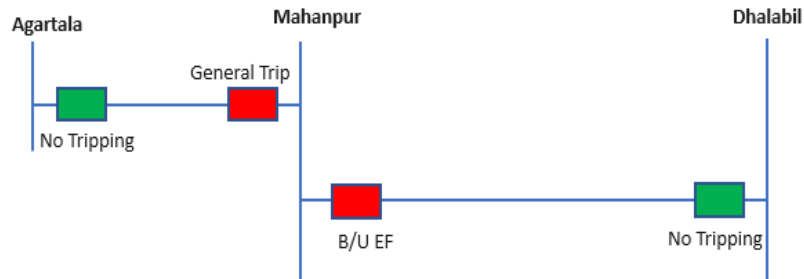

At 02:33 Hrs on 29-Sept-2023 both 132 kV Agartala- Monahpur Line & 132 kV Dhalabil - Mohanpur line tripped from the **Mohanpur end** on operation **Earth Fault** and **General Trip** which led to **blackout of Mohanpur Substation**. No tripping was observed from the other end such as Agartala & Dhalabil.

Root cause cannot be concluded due to non-submission of DR and EL by TPTL.

TPTL is requested to share the root cause of tripping and remedial measures taken.

Deliberation of the sub-committee

Tripura representative was not present; hence matter could not be discussed. The issue will be taken up in next PCCM.

B.16 Tripping of 132 kV Biswanath Chariali (PG) - Gohpur Line on 02-10-2023:

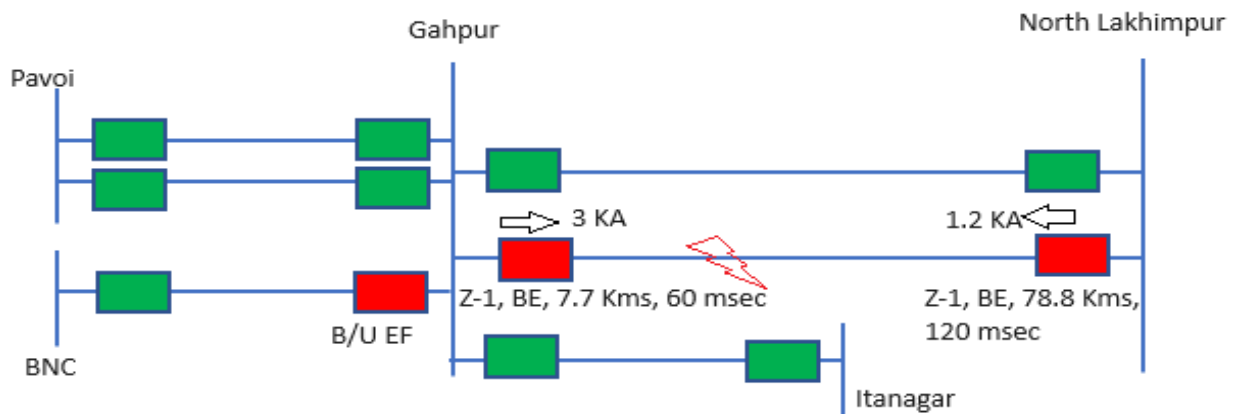

At 10:59 Hrs on 02-10-2023, Phase to E fault occurred in 132 kV Gohpur - North Lakhimpur 1 and cleared from Gohpur within 60 msec and from N Lakhimpur within 120 msec.

At the same time 132 kV BNC line tripped from Gohpur on dir B/U EF (421 A) within **40 msec** which inferred to be **UNWANTED**.

AEGCL is requested to intimate the root cause and remedial measures taken after the event.

Deliberation of the sub-committee

AEGCL intimated that Backup E/F relay operated at BNC due to fault in reverse direction as Main-2 relay B-phase PT fuse blown resulted in improper prediction of directionality at BNC end. Fuse has been replaced by spare one. The necessary action for rectification will be taken soon.

B.17 Blackout of Dharmanagar area of Tripura power system:

Event 1(15-09-2023):

Dharmanagar area was radially connected with rest of NER grid through 132 kV Dharmanagar - Dullavchera line.

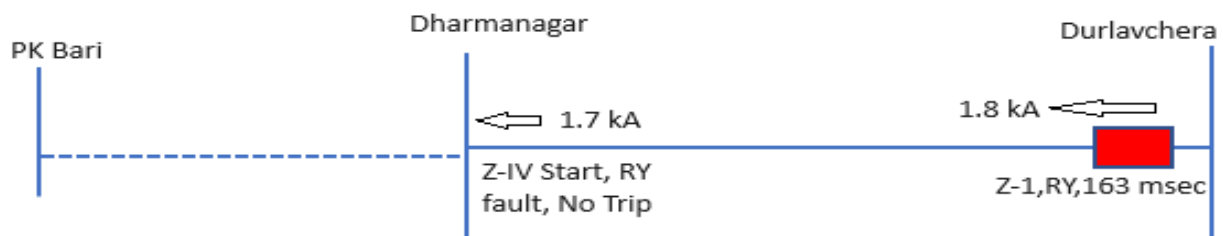

At 11:43 Hrs on **15-09-2023**, 132 kV Dharmanagar – Dullavchera Line tripped from Dullavchera on Z-1 operation within 163 msec. No tripping recorded from Dharmanagar end as it detects fault in Z-IV. It seems that Phase-to-Phase fault was in downstream side of Dharamanagar.

Following needs to be intimated-

Exact location of fault and its action taken by **TPTL**.

Reason of Tripping on Zone I by **AEGCL (if there is any over-reaching)** and actions taken.

Event-2(19-10-2023):

Dharmanagar area was connected with rest of NER grid through 132 kV Dharmanagar - Dullavchera line and 132 kV Dharmanagar-PK Bari Line.

At 01:47 Hrs, 132 kV P K Bari -Dharmanagar Line and 132 kV Dharmanagar – Dullavchera Line tripped which led to blackout of Dharamanagar area of Tripura Power system. Load loss of **22 MW** recorded at Dharmanagar area of Tripura power system, which is the matter of concern.

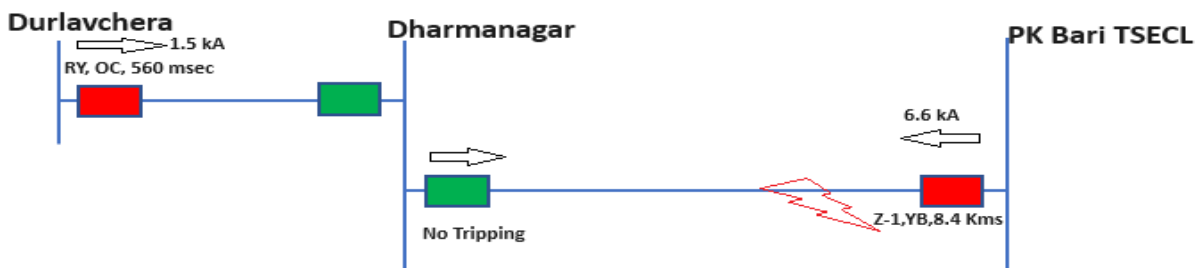

Phase to Phase fault was in 132 kV PK bari-Dharmanagar Line and fault was cleared from PK Bari within 60 msec. Protection system at Dharmanagar **fails to isolate** the fault, due to which fault was feeding continuously from adjacent healthy Line 132 kV Durlavchera-Dharmanagar from Durlavcherra end and finally clear the fault within 560 msec on B/U O/C protection.

TPTL is requested to intimate the following-

1. The reason of non-clearing of fault from Dharmanagar and its remedial measures.
2. Reason of non-Submission of DR and EL from Dharmanagar S/S

Deliberation of the sub-committee

Event 1

AEGCL has checked the relay setting at Dullavcherra and found okay. However, NERLDC raised the concern of tripping in ZI at Dullavcherra due to fault beyond the 132 kV Dullavcherra – Dharmanagar line. Forum requested AEGCL to share the settings with RLDC and check the relay settings with Trans-Play.

Event 2

Tripura representative was not present; hence matter could not be discussed. The issue will be taken up in next PCCM.

B.18 Blackout of Dimapur area of Nagaland power system on 15th and 16th September 2023:

Dimapur (Nagarjan) area of Nagaland power system was connected with rest of NER grid Via. 132 kV Dimapur (PG)-Dimapur (Nagarjan) D/C.

At 18:30 hrs of 15-09-2023 and 17:38 Hrs of 16-09-2023, 132 kV Dimapur (PG)-Dimapur (Nagarjan) D/C tripped leading to blackout of Dimapur (Nagarjan) area of Nagaland Power System, which is the matter of concern.

Due to the above, load loss of around **110 MW and 96 MW** recorded.

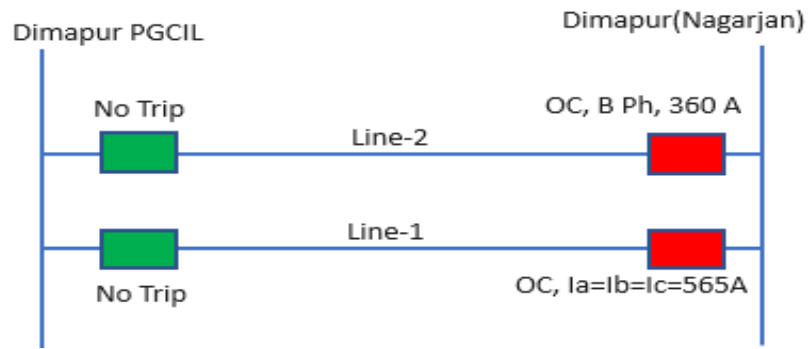

Sequence of Events -

1. 132 kV Dimapur – Dimapur 2 tripped at Nagaland end on operation of OC with $I_a = 308 \text{ A}$, $I_b = 320 \text{ A}$ and **$I_c = 360 \text{ A}$** within 28.6 sec (**OC pickup:360A**)
2. Subsequently after tripping of line II, whole load shifted to 132 kV Dimapur – Dimapur 1 led to tripping of Line-I on OC within 5.7 sec (**Phase current $I_a = I_b = I_c = 565 \text{ A}$**)

Key Observations-

1. There is no fault in the system as per DR/PMU signal.
2. About **40A -50 A** less current observed in B-phase as compared to other R & Y phase in Line-1. This 50 A current is added to B-phase of parallel line-2 which led to tripping of Line-2 on over current. It seems that there is some issue with primary side connection, which may be due to loose jumper joints/isolator etc that creates high impedance path in B-phase of Line-1.

In order to identify the issue, NERLDC requested DoP Nagaland to do the following-

- Line impedance parameter test of Line-1
- Thermovision scanning of Line-1 & 2 during peak hours to locate the loose joints/hot spots etc.
- CRM test of CB and isolator

As reported by DoP Nagaland, all parameters are within limit after testing of CRM (CB/ISO) and thermal scan (bay/Line).

NERLDC suggested

1. **DoP Nagaland** to carry out thermal scanning during loading condition.
2. **PGCIL** to carry out line impedance measurement test so that imbalance current issue may be known.

- DoP Nagaland to increase the Overcurrent relay setting to 420A (**91 MW**) or 70% of CT ratio as discussed in the 206th OCCM.

Deliberation of the sub-committee

Forum requested DoP Nagaland to check tightness of each bay elements from gantry tower to CB at Nagarjan end.

Forum also requested DoP Nagaland to implement directionality in OC protection in accordance with NERPC protection Philosophy which is forward only.

PGCIL was also requested to set OC pick up setting to 100 % (i.e., 600 Amp) at their end.

B.19 Requirement of SPS implementation at Dimapur to for ensuring reliable power in Dimapur area of Nagaland:

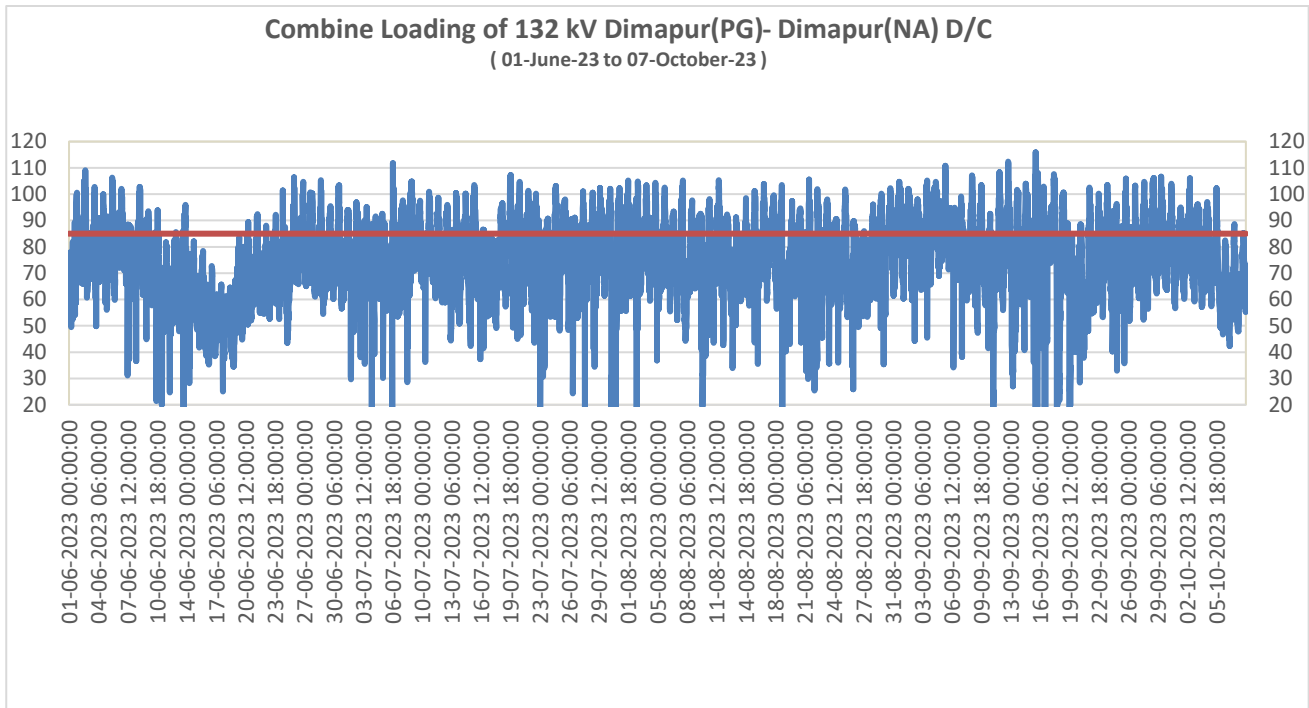

Loading profile of Dimapur shows N-1 contingency of any one circuit not satisfied most of the time as the combine loading was above 85 MW for 22% of times and above 80 MW for 35% of times.

Hence, to satisfy the N-1 contingency at Dimapur (NL) and to avoid load loss in the Dimapur area, DoP, Nagaland is requested to implement suitable System Protection Scheme (SPS) with following criteria-

If the loading of any one circuit current exceeds more than 415A, the SPS will trigger and it will shed 25-30 MW load at Nagarjan area, which will increase the reliability of Nagarjan area of Nagaland system.

Deliberation of the sub-committee

DoP Nagaland updated that reconductoring of the line is under process, DPR is in final stage.

Regarding the SPS, forum requested DoP Nagaland to identify 25-30 MW load at Nagarjan area for the implementation of the SPS scheme at the earliest.

B.20 SPS for tripping of 132 kV Panyor-Ziro line:

The reliability of Ziro, Daporijo, Along, Pasighat, Roing, Tezu, Namsai, Chapakhowa, Ledo and Rupai area has been increased after commissioning of 132 kV Roing-Chapakhwa DC in the month of July 2023.

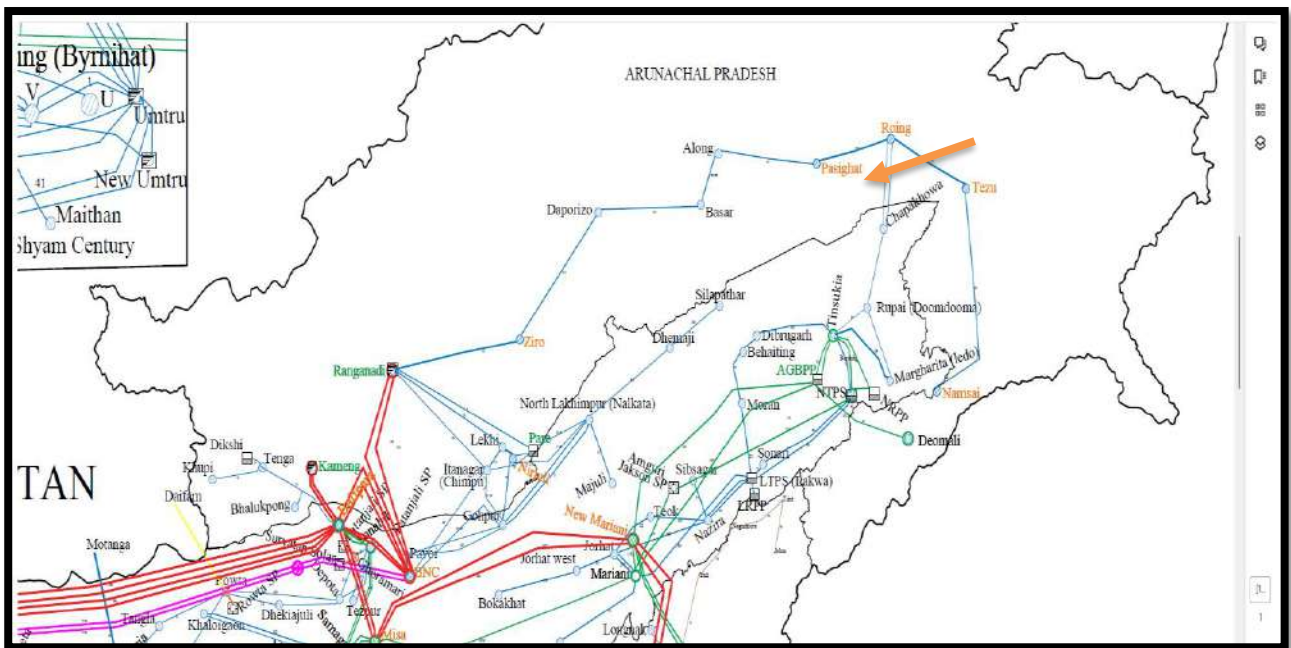

Since its integration into the grid on 4th July 2023, the 132kV Chapakhowa-Roing D/C line has successfully prevented multiple number grid disturbance in Arunachal Pradesh. The details are given below.

Sl. No	Elements Tripping	Tripping count
1	132 kV Daporijo – Basar- Along Line	6 Times
2	132 kV Along - Pasighat Line	30 Times
3	132 kV Daporijo - Ziro Line	9 Times

Study suggests that a severe low voltage issue may arise on tripping of 132 kV Panyor-Ziro line and may lead to cascading tripping in Arunachal Pradesh powers system. In such case, SPS may be designed to isolate the downstream load of Ziro substation on tripping of 132 kV Panyor-Ziro line.

Deliberation of the sub-committee

DoP Ar. Pradesh agreed to proposal of SPS at Ziro and assured that downstream lines will be identified shortly.

The forum asked NERLDC to prepare the SPS scheme logic and submit to NERPC /concerned Utilities for further implementation at the earliest. The SPS will be implemented by POWERGRID at Ziro and Paynor HEP by NEEPCO.

Agenda form NERTS

B.21 Frequent faults in 33kV system of Ziro:

Frequent faults observed in 33kV feeders at Ziro substation. Same maybe looked into for rectification by DoP Arunachal as otherwise ICT at Ziro is getting stressed.

List of faults is as given under: -

Sr. No.	Name of Feeder	Month / No. of tripping	Total
1	Old Ziro	April - 11 May - 11 June - 9 July - 10 August - 18 September - 12	70
2	Kimin	April - 28 May - 36 June - 21 July - 39 August - 46 September - 34	204
3	Kurung - Kumey	April - 44 May - 61 June - 51 July - 46 August - 61 September - 57	320

Deliberation of the sub-committee

DoP Ar. Pradesh assured that the matter will be taken up at the higher authorities and vegetation clearance along the lines will be undertaken regularly.

Further DoP Ar. Pradesh stated that with the commissioning of Ziro-Yazali-Palin lines, under Comprehensive Scheme, Kimin and Kurung loads will be disconnected from Ziro substations and will be fed from Yazali substations, thus the problem will be automatically addressed.

Subcommittee noted as above

B.22 Providing PLCC in State owned lines /bays:

a. 132kV Dimapur Kohima line (Length – 58 km) - 132kV Dimapur - Kohima bay at Dimapur end is maintained and owned by PGCIL. Of this line, 350mtr is owned by POWERGRID whereas balance is owned by DOP – Nagaland. Presently, there is no PLCC available in this state owned line. Due to this, Carrier aided tripping is not possible which shall lead to higher fault feeding in case of Zone 2 fault from each end. The same may cause disturbance also.

Further, bay at POWERGRID end is GIS. On SF₆ gas pressure low, isolation from remote end is utmost important looking at the safety of the equipment and grid. Without PLCC, DT implementation cannot be achieved. This matter needs to be taken up for rectification at the earliest.

b. 132kV Melriat Zemabwk (Length – 10.12 km) – PLCC link is not established for 132kV Melriat – Zemabwk line owned by POWERGRID. Spare PLCC panels alongwith wave trap is available at Melriat substation. However, due to non-availability of 48V dc supply at Zemabwk end, the PLCC link cannot be commissioned. DoP Mizoram is requested to arrange the 48V dc supply to commission the PLCC link.

c. 132kV Nirjuli Lekhi (Length is 11kms) – 132kV Nirujli Lekhi line is maintained jointly by DoP AP & POWERGRID (5 km DoP, 6 km POWERGRID). PLCC link is not available for this feeder. Earlier this line was between Ranganadi and Nirjuli where PLCC was provided. However, after LILO at Lekhi by DOP-AP, PLCC was shifted to Lekhi – Ranganadi Section and PLCC was not provided in Nirjuli – Lekhi section. As per standard protection practice, PLCC needs to be available for 132kV lines. Therefore, DoP AP is requested to look into the installation & commissioning of PLCC at both ends.

Deliberation of the sub-committee

- a. 132kV Dimapur Kohima line (Length – 58 km):** DoP informed that currently PLCC ABB, ETL-41 is working at Kohima which supports Speech & data only. OPGW has already been laid. Nagaland will implement carrier scheme through DTPC (Digital tele-protection coupler).
- b. 132 kV Melriat-Zemabawk line (Length – 10.12 km):** Mizoram not present. However, the forum requested DoP Mizoram to arrange the 48V dc supply at Zemabawk to commission the PLCC link.
- c. 132 kV Nirjuli-Lekhi line (Length – 11 km):** Forum requested DoP Ar. Pradesh to implement the PLCC link on the said line and the option of PSDF funding under reliable communication may be explored. Ar. Pradesh informed that it will be installed in the next FY 2024-25.

B.23 PLCC issues:

- a. 400kV Mariani Kohima Ckt #2** - For 400kV Mariani-Kohima Ckt-2, ABB make PLCC Model no-ETL41 is installed at both ends. PLCC panels at both ends are owned by KMTL. At Mariani end, for PLCC Ch#1, alarm is persisting in P4LA card. KMTL had previously deputed service engineer for rectification of the issue in Oct 2022. The issue was resolved in Oct 2022. However, the same issue had resurfaced again from 24th August 2023. Repeated communication has been sent to KMTL to resolve the issue. However, rectification action is still pending.
- b. 132 kV Roing - Pasighat** – PLCC panels for 132kV Roing -Pasighat feeder are installed at both ends. Panels are in healthy condition at both ends. However, due to non-availability of healthy 48V dc supply at Pasighat end, PLCC panels at Pasighat are in OFF state. DoPAP is requested to arrange healthy 48V dc supply at Pasighat end.
- c. 132kV Dimapur - Bokajan** – For safe and rapid isolation DT scheme is required as per standard practice. However, 132kV Dimapur-Bokajan feeder, DT send scheme is not implemented at Bokajan end (AEGCL). AEGCL is requested to implement the same.
- d.** As per latest practice of POWERGRID, to prevent unwanted DT send due to DC flickering earth fault, a standard time delay of 10 msec is being added in all Protection Couplers (DTPC / PLCC) having provision for the same. Same maybe allowed in all lines having DTPCs (owned by other utilities) connected to

POWERGRID substations:

<u>Sr. No.</u>	<u>Name of Line</u>	<u>Owner of DTPC / PLCC</u>
1	132kV BNC-Gohpur	Indigrid
2	132kV BNC-Itanagar	Indigrid
3	132kV Badarpur-Karimganj	AEGCL
4	220kV Balipara – Sonabil Ckt 2	AEGCL

Deliberation of the sub-committee

- a. KMTL not present, hence issue could not be discussed.
- b. DoP AP will do the needful by the end of March-24.
- c. DT Scheme already implemented at Bokajan by AEGCL.
- d. Director, NERPC informed that Indigrid vide mail dt. 30.10.2023 has intimated that IndiGrid is ready to incorporate a time delay of 10 msec to prevent maloperation of DT in the Itanagar Bay for 132kV BNC-Itanagar Line, however, requiring support of GE (OEM) to configure. IndiGrid further intimated that the Gohpur bay (132kV BNC-Gohpur Line) is not under IndiGrid's ownership and so required changes would have to be incorporated by AEGCL team.

Forum advised all the utilities to add time delay of 10 msec in the protection coupler (PLCC/DTPC) to prevent spurious/unwanted DT signal sent due to DC earth fault flickering (Any DC earth fault flashover sustain for < 10 msec as per PGCIL experience). PGCIL was advised to send e-mail regarding the existing practice to Indigrid and AEGCL and NERPC.

B.24 Auto reclose related issues:

- A. Auto Reclose is a standard requirement which is not functional for the following feeders:
 - a. **132kV Dimapur-Doyang 1&2** – At Doyang end, AR is not functional. NEEPCO may kindly look into it to enable it.
 - b. **132kV Dimapur-Bokajan** - Auto reclose for this line is not functional at Bokajan end.
 - c. **132kV Dimapur-Dimapur 1 & 2** - Auto reclose for these lines are not functional at state end. DoP Nagaland is requested to enable the AR feature.

B. As per standard practice of POWERGRID, 3-ph AR is enabled for all 132kV lines. For 132kVBNC-Gohpur & 132kV BNC-Itanagar ckt, only 1-ph AR is enabled. As line belongs to Indigrid, consent maybe accorded to enable 3-ph AR at both ends. Enabling of 3-ph ensures that for all types of faults (1-ph, ph-ph, 3-ph faults), AR shall be initiated which will increase system availability.

Deliberation of the sub-committee

AEGCL stated that they will be implementing AR at Bokajan end by November'23. Nagaland informed that they have implemented without carrier in respect of both the ckts.

NEEPCO was requested to look into the issue and consider to enable the AR.

Director, NERPC informed that Indigrid vide mail dt. 30.10.2023 has provided consent for enabling of 3-Ph AR for 132kV BNC-Gohpur & 132kV BNC-Itanagar. IndiGrid requested for the prior approved settings for incorporation of changed settings in P442 and PSL Logic for enabling 3-Ph AR in the Itanagar bay for 132kV BNC-Itanagar, falling under IndiGrid's ownership.

Subcommittee noted as above.

B.25 Non reporting of bays to RLDC

During commissioning of SAS & CRP at AEGCL Srikona, Gohpur, Pavo, RTU was dismantled. Therefore, data of POWERGRID owned bays are not reporting to RLDC. AEGCL may restore the RTUs and set up the communication link upto SLDC/RLDC at Srikona & Pavo. Thereafter, wiring of equipment status upto RTU shall be done by POWERGRID.

Deliberation of the sub-committee

Forum requested Assam to resolve the matter by the next PCCM.

Agenda form NETC

B.26 Correction of the settings of the relays associated with NETC transmission line elements and installation of TWFL in connected S/S.

North East Transmission Company Limited (NETC) is currently operating the 400 kV D/C Palatana-Silchar and Silchar-Bongaigaon T/L with connectivity through LILO line at Byrnihat (Meghalaya) and at Azara (Assam) for evacuation of power from OTPC power plant located at Palatana, Tripura to NER States.

A Single line diagram showing the connectivity of the 400 kV Palatana-Bongaigaon Transmission system is as follows:

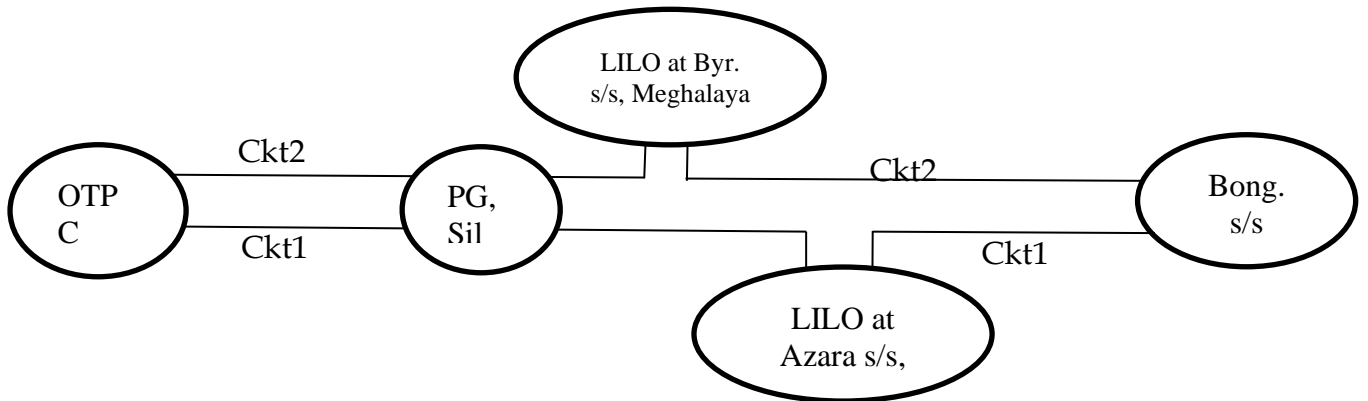

During the last financial year (FY 2022-23), there were instances of tripping in the 400 kV D/C Palatana-Bongaigaon Transmission System. Due to inaccurate fault calculations of the relays, difficulties were faced in detection of fault location. In normal scenarios, we expect to locate the faults within a range of +/- 5 km from the relay distance measurement. However, during post-fault patrolling, we discovered fault locations approximately 10-15 km away from the relay's calculated distance. The same issue persisted for the tripping instances during the current Financial Year (2023-24) as well. Here is a brief overview of such tripping instances:

SL. No.	Name of line element	No. of tripping occurred during		Remarks
		FY 2022-23.	FY 2023-24 till Sept 2023	
1	Palatana-Silchar line 1	12	2	During the all these tripping(s), the distance indications of the relay were wrong.
2	Palatana-Silchar line 2	4	4	
3	Silchar-Azara	7	2	
4	Silchar-Byrnihat	10	8	
5	Byrnihat-Bongaigaon	2	1	
6	Azara-Bongaigaon	0	0	

In view of above, we propose the following for detail deliberation by the forum:

- i) A comprehensive review of the relay setting arrangements and implementation of the modified setting in conformity with the actual line parameters at all the connecting substations.

- ii) Installation of the travelling Wave-Based Fault Locators (TWFL) at all the aforementioned connecting substations to ensure smooth and effective operation of the lines by precisely locating faults in cases of the line tripping.

Deliberation of the sub-committee

AEGCL representative stated that there is no issue with relay settings and line parameters. Further he stated that some error in fault distance is inevitable in case the fault involves the ground. He suggested to adopt some kind of methodology by which such error may be minimized.

Forum decided that RPC, NERLDC, NERTS, AEGCL and NETC will jointly discuss to address the issue as suggested by AEGCL. A comprehensive review of the line parameters and relays settings will also be undertaken jointly by NERPC, NERLDC NETC and concerned bay owners.

To research the fault location, DR data from Azara/Byrnihat needs to be reviewed by AEGCL/NERLDC during tripping of any one line of 400 kV Azara-Silchar and Byrnihat-Silchar line as there is no mutual compensation wiring at LILO Azara & Byrnihat SS.

Regarding TWFL, the forum decided that proposal may be considered only after the measures, as suggested above are not fruitful.

Agenda form MePTCL

B.27 Requirement of SPS for 132 KV Khliehriat (PG)-Khliehriat D/C line

With expected availability of at least two machines of Kopili and one machine of Khandong during peak hours of the coming winter months of 2023-24 and considering the anticipated increase in demand, it is expected that total power flow along 132 KV Khliehriat (PG)-Khliehriat D/C line would be between 90-110 MW under different conditions. Load flow studies had been carried out by SLDC and shared with NERLDC. The matter had also been discussed with DGM, NERTS since 132 KV Khliehriat (PG)-Khliehriat line 1 is under POWERGRID. The scheme envisages shedding of 20-25 MW load at 132 KV Mustem substation in the event of tripping of any circuit of 132 KV Khliehriat (PG)-Khliehriat D/C line.

The above requirement was agreed in principle during the 205th OCC meeting and NERLDC and MePTCL were requested to develop the tripping logic and to present it in the next PCC meeting. The schematics of the SPS is attached for reference.

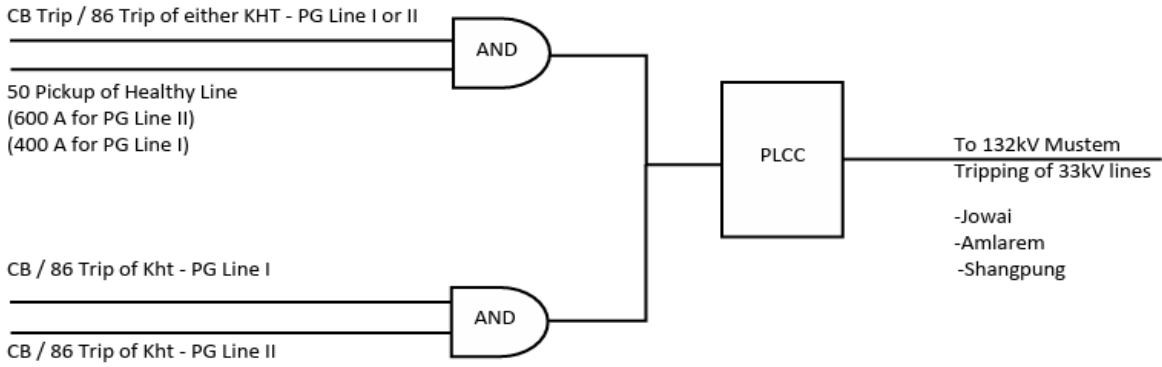
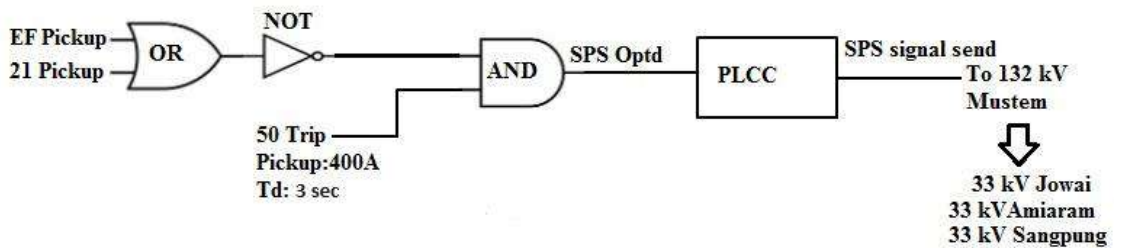

Fig: SPS Schematics at 132kV Khliehriat S/S for 132kV PG Line I & II

Deliberation of the sub-committee

NERLDC provided the modified logic (as below) and same need to be implemented by MePTCL. MePTCL agreed the same.

SPS Logic Diagram



C. Follow-up Agenda items

C.1 Grid disturbance in Umtru & New Umtru areas of Meghalaya Power System on 23th July'23 (59th PCCM)

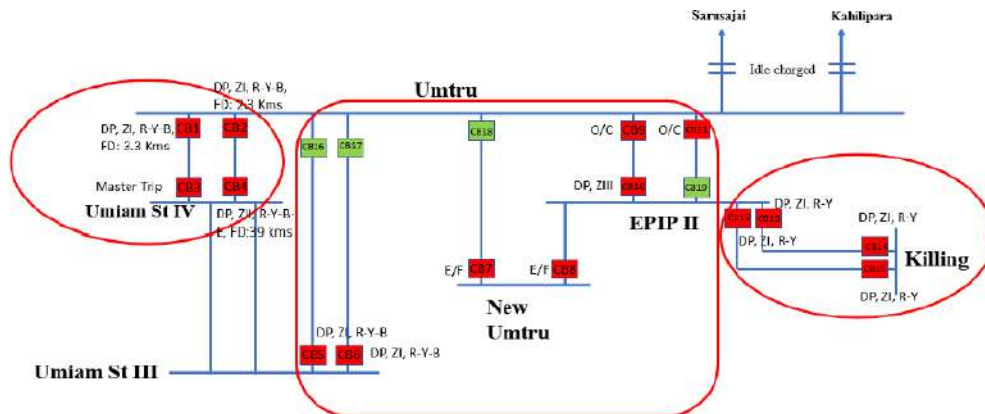

Deliberation of the 59th PCCM

- i)** Regarding non-operation of protection at Umtru for Umiam stg III lines, MePGCL updated that relays have been checked and found to be ok. The forum requested MePGCL to recheck the protection system and intimate NERPC and NERLDC about the root cause.
- ii)** MePGCL assured the forum to send the relay settings of lines at Umtru and new Umtru to NERPC/NERLDC.
- iii)** The forum strongly requested MePGCL to disable the High Set definite time Back up O/C and E/F settings as per the NER protection philosophy.

MePGCL may update the latest status.

Deliberation of the sub-committee

Regarding non-operation of protection system at Umtru for Umiam stg III lines, MePTCL informed that the 86A relay was defective resulting in non operation at Umian end during fault. The same has been rectified.

The forum strongly requested MePGCL to disable the High Set definite time Back up O/C and E/F settings as per the NER protection philosophy.

MePTCL informed that the matter will be discussed in their state OCCM.

C.2 Tripping of 132 kV Khlieriat-Khlieriat-2 Line along with 132 kV Khlieriat-Lumshnong Line (59th PCCM)

At 15:24 Hrs on 8th June'23, three phase fault was in 132 kV Khlieriat-Lumshnong Line and it was cleared within 70 msec from Khlieriat on Z-1. At the same time, 132 kV Khlieriat-Khlieriat-2 Line tripped from Khleiriat(PG) on Z-1 which is unwanted. Similar kind of event also occurred at 23:35 Hrs on 15/05/22.

As per NERLDC record, LDP (Line Differential Protection) has been implemented on the 132 kV Khlieriat-Khlieriat-2 Line as line length is less than 10 Km.

Observation-

With LDP in place, distance protection should not come into operation except in case of failure in the optical fiber link or a failure in the LDP relay.

MePTCL is requested to intimate the root cause of tripping of 132 kV Khlieriat-Khlieriat-2 Line and remedial actions taken.

In 59th PCCM, the forum decided that on short lines with differential protection as primary protection, there should be a delay of 100 msec in Zone 1 of the backup distance protection.

Deliberation of the sub-committee

MePTCL updated that delay of 100msec has been inserted in Zone 1 of back up distance protection.

Also, regarding the philosophy of implementing delay in zone 1, NERLDC and NERTS opined that the philosophy should be applied on case-to-case basis and not uniformly in every situation.

After due deliberation the forum agreed to the suggestion and decided that –

- i. Generally, there should be no delay inserted in the Zone 1 of back up distance protection as zone 1 automatically gets enabled when there is failure on communication link.
- ii. Decision to insert delay of 100msec in zone 1 will be taken on case-to-case basis after discussion with NERPC, NERLDC and concerned utilities.

Forum suggested MePTCL to provide Line Differential Protection healthiness /fiber cut status to standalone DPR from LDP so that Z-1/distance protection should be activated only in case of LDP failure/Fibre optic link failure.

C.3 Implementation of Bus Bar protection scheme at Kahilipara (57th PCCM)

Sl No	Description of Event	Action Already Taken	Recommended actions in last sub- group	Discussion Points	Deliberation of the Subgroup
35.	Tripping of 132 kV Kahilipara - Sarusajai 1, 2 and 3 line, 132 kV Kahilipara Main Bus I, 132 kV Kahilipara Transfer Bus I and 132 kV Kahilipara - Kamalpur Line on 02.08.21			->R-Y phase bus fault at Kahilipara. ->Z2 protection operated at Sarusajai end for line 1,2 and 3. ->Z5 picked the fault at Kahilipara for all the feeders.	->BB protection to be implemented at Kahilipara With procurement of 5 core CTs

ATEGCL may update

Deliberation of the sub-committee

ATEGCL informed that it will be done in next 6 months.

C.4 Blackout of Zuangtui area of Mizoram System on 25.07.23

Grid disturbance of category GD-1 (Load loss: 20 MW) occurred at Zuangtui and Saitual substations of Mizoram state at 13:13 Hrs of 25/07/2023 due to tripping of 132 kV Melriat(PG) – Zuangtui & 132 kV Serchip-Zuangtui lines which is the cause of concern.

As per DR analysis, highly resistive B ph fault was in 132 kV Zuangtui – Serchip line and it was cleared within 431 msec from Zuangtui on In>1 (396 A). At the same time, Melriat – Zunagtui line tripped from Melriat on In>1 (331 A)

Observation:

- i. P&ED Mizoram is requested to intimate the root cause of tripping of 132 kV Zuangtui – Serchip line.
- ii. ROT of EF settings at Melriat for Zunagtui line and Zuangtui for Serchip line seems low and is overlapping. So, proper coordination is to be done by POWERGRID and P&ED Mizoram to prevent unwanted tripping.

In 59th PCCM, it was decided that NERPC, Mizoram and PGCIL will coordinate to revise the current pick up and TMS values of backup E/F and O/C relays for Melriat-

Zuangtui and Zuangtui-Serchip lines so that overlapping in relay operation may be avoided.

Deliberation of the sub-committee

NERTS updated that the relay settings as suggested by NERPC has been implemented at Melriat.

Status of implementation of settings at Zuangtui could not be ascertained as no representative was present from Mizoram.

C.5 Ensuring Reliable Power Supply at Dimapur (Nagarjan) area:

On 02-08-2023 at 16:35 Hrs, 132 kV Dimapur (PG)- Dimapur (NL) II line tripped on Zone I due to snapping of Y-Phase jumper. This led to shifting of entire load to 132 kV Dimapur (PG)- Dimapur (NL) I Line which resulted in tripping of the line on Overcurrent. Due to the GD, load loss of 85 MW observed in the Dimapur area of Nagaland power system which is the cause of concern.

The present CT ratio of 132 kV Dimapur (PG) – Dimapur (NL) D/C is 600/1 and the present overcurrent setting of 360 A at Dimapur (NL) end with each circuit carrying capacity of 82 MVA, thus not complying with N-1 criteria.

To satisfy the N-1 contingency at Dimapur (NL), following measures may be taken by DoP, Nagaland:

i. Increase the Over current settings from 360 A to 450 A at Dimapur (NL) to cater to a maximum load of 102 MVA.

ii. Implement an SPS scheme

Suggested Logic: When current in either of the circuit crosses 360 A with time delay of 1.1 sec, load shedding of around 35 MW to be done.

In 59th PCCM, the forum requested Nagaland to increase the overcurrent setting for 132kV Dimapur (PG)-Dimapur (NL) from present 60% to 70% at Nagaland end so that cascade tripping may be avoided in case of tripping of one line. DoP Nagaland assured that the suggested setting will be implemented shortly.

Deliberation of the sub-committee

Nagaland informed that OC settings has been changed to 420A at Dimapur state end. Forum requested DoP, Nagaland to make B/U OC direction forward from non-directional.

C.6 Zone I overreaching of 132 kV Agartala- AGTCCPP -2 on 12-July-2023:

At 12:58 Hrs on 12-July-2023, fault was in 132 kV AGTCCPP - PK Bari (TSECL) 2 Line and fault was cleared from AGTCCPP on Zone I and PK Bari on ZII. At the same time, healthy 132 kV Agartala - AGTCCPP 2 Line tripped from Agartala on ZI which is unwanted.

NERTS is requested to:

- i.** Intimate the root cause of the tripping and remedial measures taken
- ii.** Review the Distance Protection Zone settings at Agartala.

In 59th PCCM NERTS intimated that the distance protection zone settings are in order. However, during the fault the relay initially picked the fault in Zone 2 but then the fault impedance locus entered Zone 1. Further, he stated that distance relay will be checked and tested at the earliest.

Deliberation of the sub-committee

NERTS updated that the relay settings based on latest grid configuration revised and relay tested, and the issue has been rectified.

D. Items for Status Update

D.1. Status of auto-reclosure on z-1 operation for important lines:

In the discussions of the Sub-group on 12-04-2021 the following points were noted:

- a.** Auto-Reclosure is very much required for maintaining system stability, reliability and uninterrupted power supply.
- b.** Presently it will take some time for the state utilities to implement the PLCC and establish carrier communication between stations.
- c.** The operation of Auto-Reclosure on Z-I operation at the local end independent of carrier healthiness is required.

In the 57th and 56th PCC meeting the forum approved the implementation of Auto-Reclosure on Z-1 without carrier check for all lines except the lines with generating stations at both the ends and requested the utilities to implement the AR scheme at the earliest.

In 58th PCC meeting, the forum enumerated the lines where AR is to be enabled at the earliest.

Nagaland: 132kV Dimapur-Kohima line (from Kohima end)

Mizoram: 132kV Turial-Kolasib line

Manipur: 132kV Imphal-Ningthoukong

Tripura: 132kV Agartala-S M Nagar (TSECL), 132kV Agartal-Rokhia DC, 132kV Agartala-R C Nagar DC, 132kV Agartala-Budhjungnagar

Arunachal Pradesh: 132kV Balipra-Tenga, 132kV Ziro-Daporijo-Along-Pashighat link

AEGCL has updated in 58th PCCM that two 220KV substations (Jawaharnagar and Sonapur) and the 220 KV bay at Kathalguri has no auto reclosure but is expected to come up soon. Almost 60% of 132 KV substations has auto reclosure scheme and by June'23 the coverage will increase up to 90%.

Meghalaya stated in the same meeting that the petition to implement auto reclosure in all lines has been placed at MERC as the lines are very old and may snap on auto reclosing mechanism if persistent fault occurs. They stated that AR scheme has been put in place for 5 lines, but approval is required. **(Annexure D.1)**

Status as per 59th PCCM –

Sl no	State	Important Transmission lines where AR has to be enabled at the earliest	status as per 59th PCCM
1.	Arunachal Pradesh	132kV Balipara-Tenga, 132kV Ziro-Daporijo-Along-Pashighat link	No representative
2.	Assam	All 220kV and 132kV lines	For 220kV sub stations- At Sonapur, GIS work underway, support of OEM required At Kathalguri, procurement of relays underway At Jawaharnagar, WIP All works at threes substations to be completed by Nov'23 For 132kV substations- 80% work completed, by Nov'23 90% to be completed
3.	Manipur	132kV Imphal-Ningthoukong	-
4.	Meghalaya	Annexure (D.1)	AR put in place for 5 lines but approval of MERC is still awaited. The forum suggested MePTCL to do double jumpering at critical locations to ensure integrity of the old lines Meghalaya requested MS, NERPC to write a letter to higher authorities to expedite the commissioning of the AR in the intra-state lines
5.	Mizoram	132kV Tural-Kolasib line	AR implemented (TPAR). Moreover, AR implemented in – i.132kV Zuangtui-Serchip line (both sides) ii. 132kV Zuangtui-Saitual line (Zuangtui side only)

			iii.132kV Lungmual-Melrita line (Melriat side) iv.132kV Kolasib-Bairabi line (Kolasib side only)
6.	Nagaland	132kV Dimapur-Kohima line (from Kohima end)	Procurement done. AR to be enabled shortly
7.	Tripura	132kV Agartala-S M Nagar (TSECL), 132kV Agartal-Rokhia DC, 132kV, 132kV Agartala-Budhjungnagar	WIP, to be completed by 15 th September, 2023

Deliberation of the sub-committee

Latest status -

Sl no	State	Important Transmission lines where AR has to be enabled at the earliest	Lates status
1.	Arunachal Pradesh	132kV Balipara-Tenga, 132kV Ziro-Daporijo-Along-Pashighat link	PLCC installation on the line underway
2.	Assam	All 220kV and 132kV lines	For 220kV sub stations- At Sonapur, GIS work underway, support of OEM required At Kathalguri, procurement of relays underway At Jawaharnagar, WIP All works at three substations to be completed by Nov'23 For 132kV substations- 80% work completed, by Nov'23 90% to be completed
3.	Manipur	132kV Imphal-Ningthoukong	-
4.	Meghalaya	Annexure (D.1)	AR put in place for 5 lines but approval of MERC is still awaited. The forum suggested MePTCL to do double jumpering at critical

			locations to ensure integrity of the old lines Meghalaya requested MS, NERPC to write a letter to higher authorities to expedite the commissioning of the AR in the intra-state lines
5.	Mizoram	132kV Tural-Kolasib line	No representative
6.	Nagaland	132kV Dimapur-Kohima line (from Kohima end)	Procurement done. AR enabled
7.	Tripura	132kV Agartala-S M Nagar (TSECL), 132kV Agartal-Rokhia DC, 132kV, 132kV Agartala-Budjungnagar	No representative

D.2. Installation of line differential protection for short lines:

As per sub-regulation 3 of Regulation 48 of Central Electricity Authority (Technical Standards for Construction of Electrical Plants and Electric Lines) Regulations, 2022-

"For short line (less than 10 km) or cable or combination of overhead line and cable, line differential protection shall be used with built-in backup distance protection."

As per discussion in 59th PCC meeting and subsequent OCC/Sub-group meetings the status for different STUs/ISTS licensees are as follows:

Name of utility	Last updated status	Status as per 59th PCCM
AEGCL	DPR submitted to PSDF secretariat	DPR sent back by PSDF secretariat. Third party protection audit reports have to attached with the DPR
MSPCL	Revised DPR for 132kV Imphal-Imphal-III to be submitted.	To be submitted soon
MePTCL	Work completed Aug'21, but not commissioned yet. Meghalaya to	Report on line-wise status on progress of LDP

	provide line-wise status on progress of LDP commissioning work to NERPC and NERLDC.	commissioning work submitted to NERPC and NERLDC
P&ED Mizoram	Lines identified viz. 132kV Aizawl - Luangmual and 132kV Khamzawl - Khawiva. DPR submitted. PSDF approval awaited.	Will take up with SLDC whether DPR has been submitted.
DoP Nagaland	Lines identified under DPR preparation stage. Three lines were identified, viz; (i)132kV Dimapur-Dimapur-1 & 2 (ii) 132kV Doyang-Sanis.	LDP on Dimapur-Dimpaur lines completed. Regarding Doyang-Sanis line, NEEPCO to install LDR at Sanis end.
TSECL	132kV 79 Tilla-Budhjunnagar. DPR to be prepared	Cost estimate submitted to TIDC to arrange for ADB funding.

Regarding the 132kV Doyang-Sanis line, NEEPCO to procure and install the LDP relays and associated accessories at both the ends. DoP Nagaland will bear the cost corresponding to Sanis end.

NERTS and MePTCL have provided the status on LDP installation on lines in **Annexure D.2.**

Deliberation of the sub-committee

Status update -

Name of utility	Last updated status	Latest status
AEGCL	DPR sent back by PSDF secretariat. Third party protection audit reports have to attached with the DPR	Third party protection audit reports have to be attached with the DPR. WIP
MSPCL	Revised DPR for 132kV Imphal-Imphal-III to be submitted.	To be submitted soon
MePTCL	Work completed Aug'21, but not commissioned yet. Report on line-wise status on progress of LDP commissioning work submitted to NERPC and NERLDC	OPGW to be installed on some lines. LDP will be commissioned after OPGW link is established.

P&ED Mizoram	Lines identified viz. 132kV Aizawl - Luangmual and 132kV Khamzawl - Khawiva. DPR submitted. PSDF approval awaited.	No representative
DoP Nagaland	LDP on Dimapur-Dimpaur lines completed. Regarding Doyang-Sanis line, NEEPCO to install LDR at Sanis end.	Regarding Doyang-Sanis line, NEEPCO to install LDR at Sanis end. No representative from NEEPCO
TSECL	132kV 79 Tilla-Budhjungnagar. DPR to be prepared. Cost estimate submitted to TIDC to arrange for ADB funding.	No representative

D.3. Status for SPS

	Name of SPS	SPS Trigger/Action	Utility	Latest Status/Discussion points
1.	SPS related to secure & reliable operation of Leshka HEP	Upon tripping of one circuit of 132kV Leshka-Khliehriat D/C, Leshka generation to be reduced	MePGCL	Logic and scheme has been finalized. Modification in Protection scheme of units and extending the SPS signal to the UCB by M/S Hitachi is pending. M/S Hitachi yet to communicate with MEPGCL and provide the price offer

Deliberation of the sub-committee

Status as provided by utilities –

	Name of SPS	SPS Trigger/Action	Utility	Latest Status/Discussion points
1.	SPS related to secure & reliable operation of Leshka HEP	Upon tripping of one circuit of 132kV Leshka-Khliehriat D/C, Leshka generation to be reduced	MePGCL	Communication with M/s Hitachi is under way. Cost estimate will be finalized soon

D.4. Status against remedial actions for important grid events:

Sl No	Details of the events(outage)	Remedial action suggested	Name of the utility	Latest status (60 th PCCM)
1.	132 kV Balipara-Tenga line in May and June	Carrier aided inter-tripping to be implemented for 132kV Balipara-Tenga-Khupi at the earliest (PLCC has to be installed on the link. Under consideration of the higher authorities)	DoP, Arunachal Pradesh. As per previous updates, Work covered under PSDF. In progress	Same status
2.	132 kV DoyangMokokchung line 132 kV Mokokchung - Mokokchung (DoP, Nagaland) D/C lines on 30th July	Carrier inter-trip for 132kV DHEP-Mokokchung to be implemented by DoP Nagaland (NO PLCC on the line. Matter under consideration of Higher authorities)	DoP Nagaland (Work under progress. Will be completed soon.)	WIP
3.	Leshka-Khleihriat DC multiple tripping in April to September	TLSA installation along the line to be done by MePTCL	MePTCL (DPR submitted, Approval pending.)	Approval pending
4.	132 kV Loktak-Jiribam line, 132 kV Loktak-Imphalline,132 kV Loktak-Ningthoukhong line, 132 kV Loktak-Rengpang line &Loktak Units 1,2 and 3 on 3rdAug	> 5MVA TRAF0 (Aux. Transformer) to be repaired ->5MVA Auxiliary TRAF0 panel to be repaired by NHPC	NHPC (Order to be placed soon. Will take 6months after placing the order)	No representative from NHPC
5.	Grid disturbance of category GD-1 (Load loss: 13MW) occurred at Karong areas of Manipur Power System at 07:41 Hrs on 4th August'22	MSPCL to check the following1. Protection setting at Karong along with circuit wirings from DPR to CB mechanism 2. Z-III setting at Imphal and its healthiness of correct operation by relay testing.	MSPCL	
6.	PLCC & protection related issues at 132kV Tipaimukh S/S	MSPCL to ensure uninterrupted service of PLCC system at	MSPCL	48 Volt DC battery to repalced

		132kV Tipaimukh S/S.		
7.	Grid Disturbance at Loktak HEP on 03rd Aug'22	NHPC-Loktak informed that LBB has been included under R&U scheme and the same shall be commissioned by Mar'23	NHPC (LBB to be commissioned under R&U project and by the end of Nov'23)	LBB to be commissioned under R&U project and by the end of Nov'23
8.	Multiple tripping occurred at PK Bari-PK Bari and PK Bari-Kumarghat Line on 4th July 2022.	-> Healthiness of Carrier aided POTT scheme needs to be ensured by TSECL -> LDP needs to be implemented in 132 kV PK Bari-Kumarghat Transmission line. TSECL is requested to update the status of installation of LDP to this end -> After installation of DTPC at PK Bari end and Kumaraghat end by PGCIL, Inter-trip will now be enabled between Kumaraghat and P K Bari after TSECL assists in connection of Relay to DTPC panel at P K Bari end.	TSECL, NTL (->LDP to be implemented by September'23 ->Inter trip at PK Bari to be configured. Will be completed by August.)	NO representative from Tripura
9.	At 19:36 Hrs of 18-04-23, Grid Disturbance of category GD-1(Load Loss:120 MW) occurred at Ghoramari, Depota, Rowta and Dhekiajuli areas of Assam system due to tripping of 132 kV Sonabil-Ghoramari and 132 kV Sonabil-Depota Line	an SPS has to be devised for preventing overloading of the lines till the lines reconducted with HTLS conductors	AEGCL, NERLDC	

10.	Review of SPS at Monarchak (item 2.22 of the sub-group held on 4 th May 23)	NERLDC requested NEEPCO and Tripura to implement the revised logic at Monarchak (as provided by NERLDC) and Udaipur Rokhia ends respectively	NEEPCO, TSECL (SLDC TSECL intimated that logic 1 (to be configured at Udaipur and Rokhia to send DT to Monarchak) could not be implemented as there is no PLCC/OPGW connectivity in the LILO portion of Monarchak. NERLDC requested TSECL to explore installation of PLCC/FO for smooth functioning of SPS scheme for the reliability of Monarchak system)	
11.	Blackout of 220kV Salakati GSS on 18 th of November, 2022	commissioning of the Bus Bar protection at 220 kV BTPS(Assam) S/S	AEGCL. Offline testing done. To be enabled in few days	completed
12.	Bus Bar Protection at 220 kV Mariani (Assam) Substation	Commissioning of Bus Bar Protection at 220 kV Mariani (Assam) Substation	AEGCL To commissioned by September end	completed
13.	132 kV Aizawl - Tipaimukh Line tripped at Aizawl end only on received of spurious DT signal on 16 th and 26 th Feb'23	rectification of PLCC issues at Tipaimukh end by MSPCL	MSPCL	48V DC battery issue. WIP

14.	Outage of 220 KV Bus Bar Protection Scheme at 400/220/132 KV Killing SS	Bus-Bar protection of 220kV bus at Killing SS	MePTCL M/S ABB has given offer. Board's approval awaited. To be completed in 3-4 months	Approval still waited, to be completed in 3 months
15.	Retrip configuration in LBB scheme in AEGCL Hailakandi station:	In previous sub group meeting The forum opined that the retrip scheme in the LBB protection will increase reliability of the protection system and will help in preventing mal operations in connecting feeders. AEGCL agreed to the suggestion and assured that the Retrip scheme, with time delay of 100msec will be configured in the LBB scheme in Silchar-Hailakandi Ckt 1 & 2 at Hailakandi end.	AEGCL Logic finalized, need to be tested. Whole work may be completed within one month	To be completed in Nov'23
16	Non-operation of AR for various lines at Byrnihaat end on 25 th and 26 th June'23	Rectification of PLCC issues by MePTCL Consultation with OEM underway for resolution	MePTCL	Rectification of LCC underway
17	Non-operation of AR for various lines at Sonapur end in July and August	GIS related issues, coordination with OEM required	AEGCL	Coordination with OEM underway. WIP
18	Grid disturbance in Umtru & New Umtru areas of Meghalaya Power System on 23 th July'23	O/C and E/F high set settings for Umtru and EPIP-II lines at New Umtru to be disabled	MePGCL	Matter to be discussed in next OCC

DATE AND VENUE OF NEXT PROTECTION SUB- COMMITTEE MEETING

The next Protection Sub-Committee meeting will be held in the month of November, 2023. The date and venue will be intimated separately.

Annexure-I**List of Participants in the 60th PCC Meeting held 31.10.2023**

SN	Name & Designation	Organization	Contact No.
1	Sh. Hibu Bama, EE (E)	Ar. Pradesh	08119858317
2	Sh. Arup Sarmah, AGM, AEGCL	Assam	09707854367
3	Sh. Satyakan Das, AGM, AEGCL	Assam	09401371260
4	Sh. Abhishek Kalita, DM, AEGCL	Assam	08486213068
5	Dr. S.Sanjaoba Singh, DGM, MSPCL	Manipur	09774166658
6	Sh. Huidrom Rakesh Matei, Manager, MSPCL	Manipur	08792153086
7	Sh. R.Khongmalai, AEE (MRT), MePTCL	Meghalaya	08014137268
8	Sh. A.G.Tham, AEE (MRT), MePTCL	Meghalaya	09774664034
9	Sh. A.Shullai, AEE (G&PSD), MePGCL	Meghalaya	09436334458
10	Sh. Rokobeito Iralu, S.D.O	Nagaland	09436832020
11	Sh. Lengminlal, SDO	Nagaland	09436831124
12	Sh. Amaresh Mallick, CGM	NERLDC	09436302720
13	Sh. S.C.De, Sr.GM	NERLDC	09436335369
14	Sh. Bimal Swargiary, CM	NERLDC	09435499779
15	Sh. Utpal Das, AM	NERLDC	07005504075
16	Sh. Subhra Ghosh, Engineer	NERLDC	08415857079
17	Sh. P.Kanungo, CGM (AM)	PGCIL	09436302823
18	Sh. Manash Jyoti Baishya, CM	PGCIL	09435555740
19	Sh. Mitangshu Saha, Lead-STG	OTPC	07085310211
20	Sh. Anil R.Sah, DGM	NETC	09999055047
21	Sh. N.Ramesh K.Singh, AM	NETC	09101658046
22	Sh. Niranjan Rabha, AM	NETC	07002022736
23	Sh. K.B.Jagtap, Member Secretary	NERPC	-
24	Sh. S.M.Aimol, Director	NERPC	08974002106
25	Sh. Shaishav Ranjan, Dy. Director	NERPC	08787892650
26	Sh. Vikash Shankar, AEE	NERPC	09455331756
27	Sh. Somraj, AEE	NERPC	-



भारत सरकार/Government of India
विद्युत मंत्रालय/Ministry of Power
केन्द्रीय विद्युत प्राधिकरण/Central Electricity Authority
एन.पी.सी. प्रभाग/National Power Committee Division
Ist Floor, Wing-5, West Block-II, RK Puram, New Delhi-66

No.4/MTGS/SG/NPC/CEA/2023/ 353

Date: 18.09.2023

Subject: Standard Operating Procedure for Protection System Audit- reg.

Standard Operating Procedure (S.O.P) for Protection System Audit is enclosed herewith for your kind information and necessary action.

Enclosure: As above

Yours faithfully,

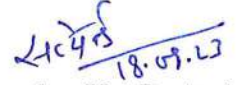
18.09.23

(सत्येंद्र कु. दोतान / Satyendra Kr. Dotan)
Director, NPC & Member Convener (Sub-group)

Standard Operating Procedure for Protection System Audit

A protection system audit is a review and evaluation of the protection systems of a substation with an objective to verify whether required protection systems have been put in place at station by the concerned utility, and to recommend suitable measures to provide for the same.

Ministry of Power, had constituted a Committee under the Chairmanship of Chairperson CEA to examine the grid disturbances on the 30th and the 31st July 2012. One of important recommendation of the committee was conducting of extensive audit of protection system. List of sub-stations where protection audit is to be undertaken on priority basis was prepared and audited across the country. This was the beginning of protection audit across the country and large number of important 400 and 220kV substations were audited.

Keeping in view the importance of Protection System Audit, Standard Operating Procedure has been prepared for the reference purpose. It will provides a step-by-step guide for RPCs to follow during the audit process.

1. All users shall conduct third party protection audit of each sub-station at 220 kV and above (132 kV and above in NER) once in five years or earlier as advised by the respective RPC.
2. After analysis of any event, each RPC shall identify a list of substations / and generating stations where third-party protection audit is required to be carried out and accordingly advise the respective users to complete third party audit within three months.
3. The third-party protection audit report shall contain information sought in the format as per IEGC 2023 and its further amendments.
4. Annual audit plan for the next financial year shall be submitted by the users to their respective RPC by 31st October. The users shall adhere to the annual audit plan and report compliance of the same to their respective RPC.
5. **Criteria for choosing substations for third party protection audit:**

The following criteria are generally applied during choosing a substation for protection audit.

- i. Substations/ Generating (SS/ GS) stations with frequent grid incidences or frequent maloperations or any grid occurrence in any substation which affected supply to large number of substations and caused significant load loss. In this case, third-party protection audit may be carried out within three months or as decided in the Protection sub-Committee Meeting of the RPC.
- ii. Based on request received from utilities for arranging protection audit in certain stations (e.g. for availing PSDF funding for Renovation and Upgradation of Protection system). In this case, preferably third-party protection audit may be carried out within three months.
- iii. Important 400kV and 765kV substations (SS) / Generating stations (GS) including newly commissioned SS/ GS. In this case, third-party protection audit may be carried out at a frequency decided in the Protection sub-Committee Meetings of respective RPCs.

6. Protection audit Procedure:

- i. After identification of stations for protection audit, the same is communicated to the owner utility seeking nomination of one nodal officer for each Station.
- ii. The nodal officer shall provide the details of substation for preparation of protection audit format (in line with IEGC and subsequent amendments).
- iii. Meanwhile nominations shall be sought from all utilities to form regional teams for audit. Regional teams comprising of engineers from various utilities /utility (other than the team of host State) of the region shall be formed based on the no. of SS to be audited. (Each team may consists of 3 or 4 engineers from utilities other than the host utility and at the maximum a team will be able to audit 3 to 4 stations in 7-9 days or so)
- iv. Once the team details and list of stations to be audited is finalised the details of nodal officers, team members , list of stations to be audited by each team is shared to all for further coordination regarding planning and conduction of audit.
- v. Based on the inputs received from nodal officer regarding the list of elements in the substation to be audited, protection audit formats shall be prepared by RPC (in line with IEGC) and circulated to nodal officer. The nodal officer along-with the substation engineers shall fill the audit format and furnish the same along-with various attachments sought as part of the audit format within a week or so. List of attachments shall be given in the covering page of audit format.
- vi. The filled in audit format along-with the received annexures shall then forwarded to the audit team by the nodal officer and any further clarification regarding the format or attachments shall be taken up by the audit team with the nodal officer under intimation to RPC.
- vii. The SS/ GS shall be audited based on the data filled in audit format checking for compliance of Central Electricity Authority (Technical Standards for Construction of Electrical Plants and Electric Lines) Regulations, 2022, Central Electricity Authority (Technical Standards for Connectivity to the Grid) Regulations, 2007 & CEA (Measures relating to Safety and Electric Supply) Regulations, 2010, CERC regulations and amendments to the same, approved guidelines of RPC, best practices in industry, report of the Task Force on Power System Analysis Under Contingencies and as per the “Model Setting Calculations For Typical IEDs Line Protection Setting Guide Lines Protection System Audit Check List Recommendations For Protection Management Sub-Committee on Relay/Protection Under Task Force For Power System Analysis Under Contingencies” etc.
- viii. After conduct of audit, the shortcomings observed in the audit shall be discussed in detail with the nodal officer and substation engineers and recommendations are finalised.
- ix. The filled in audit format along-with the recommendations and attachments shall be finalised and final protection audit report RPC (in line with IEGC) shall be compiled.
- x. Final protection audit report shall be discussed in Protection Coordination Committee and recommendations may be accepted/deleted/modified as per the scope of audit and compliance of various regulations/guidelines etc.
- xi. The recommendations of all SS audited shall be inserted into audit recommendations database and update regarding recommendations shall be sought from respective utilities.
- xii. Action plan for rectification of deficiencies detected, if any, shall be submitted to the respective RPC and RLDC and monthly progress will be submitted.

xiii. The travel expense from place of duty to Substation/Generating Station to be audited shall be borne by respective Auditor (Parent Organisation). The expense for boarding, lodging any travel of the team during the audit period shall be borne by the organisation owning the Substation/Generating Station.

Protection and UFR Audit Calendar (November'23 – May'24) - NER

Sl. no	State	Protection Audit Station	Planned Audit date (Protection + UFR)	UFR stations
1.	Arunachal Pradesh	Daporizo (132/33kV)	13 th - 17 th February'24	132kV Lekhi
		Along (132/33kV)		132k/11kV Tippi
		Pashighat (132/33kV)		33kVBandardawa
		Roing (132/33kV)		132/33kV Chimpu
		Chimpu (132/33kV)		33kV Yupia
		Khuppi (132/33kV)		132/33kV Daporijo
		Tenga (132/33kV)		33kV Dumporizo
2.	Assam	Sonabil (220/132kV)	15-19 th April'24	Samaguri (220/132/33)
		Agia (220/132/33kV)		Sankardev (132/33)
		Sarusajai (220/132/33kV)		Azara (132/33)
		Samaguri (220/132/33)		Tinsukia (220/132/33)
		BTPS (220/132/33)		Panisokua (132/33)
		Other stations already covered in protection Audit carried out in 2021		CTPS (132/33)
				Nalkata (132/33)
	Garmur (132/33)			
	Dhaligaon (132/33)			
	Bilasipara (132/33)			
3.	Manipur	Karong (132/33kV)	12-16 th May'24	KHUMAN LAMPAK (33/11kV)
		Imphal (132/33kV)		YAINGANGPOKPI (132/33kV)
		Jiribam (132/33kV)		SANGAIPROU (33/11kV)
		Rengpang (132/33kV)		WANGJING (33/11kV)
		N. Thoubal (400/132kV)		
		Churchandpur (132/33kV)		
		Kakching (132/33kV)		
		Tipaimukh (132/33kV)		
4.	Meghalaya	Byrnihaat (400/220/132kV)	16-20 th January'24	Ampati (132/33)
		Mawphlang (132/33kV)		Nangalbibra (132/33)
		Mustem (132/33kV)		Mendipathar (132/33)
		Umiam stg I (132/33kV)		Mawphlang (132/33)
		Umiam stg III (132/33kV)		Rongkhon (132/33)
		Umiam (132/33kV)		Nongstoin (132/33)
		EPIP I (132/33kV)		Mawlyndep (132/33)
		EPIP II (132/33kV)		Mustem (132/33)
5.	Mizoram	Kolasib (132/33kV)	11-15 th March'24	Luangmual (132/33kV)
		Zuangtui (132/33kV)		Shimui (132/33kV)
		Luangmual (132/33kV)		Zuangtui (132/33kV)
		Serchip (132/33kV)		
6.		Kohima (132/33kV)		Dimapur (132/66/33 kV)
		Wokha (132/33kV)		Mokokchung (132/33)

	Nagaland	Sanis (132/33kV)	11-15 th November'23	Kohima (132/33kV)
		Chepouzou (132/33kV)		
		Mokokchung (132/33kV)		
		Dimapur (132/33kV)		
7.	Tripura	Rokhia (132/33kV)	21 st -24 th December'23	Ambassa (132/33kV)
		Agartala (132/33kV)		Dhalabil(132/33kV)
		SM Nagar(132/33kV)		Udaipur (132/33kV)
		P K bari (132/33kV)		Rokhia (132/33kV)
		Udaipur (132/33kV)		
		Kumaraghat (132/33kV)		
		Ambassa (132/33kV)		
		Dharmangar (132/33kV)		
		Budhjungnagar (132/33kV)		
		Dhalabil (132/33kV)		

Observations/Recommendations:

1. Check list

Parameters	Yes/NO	Remarks
Whether redundant supply for station auxiliaries is available?		
Whether SCADA system is present?		
Whether Governor/AVR and associated panels for each units in healthy condition?		
Whether two separate DC sources provided for Main I and Main II protection ?		
Whether protection relays for generating transformers/ICTs are operational?		
Whether protection relays for emanating lines are operational?		
Whether time synchronisation facility is available in the Sub-station?		
Whether existing RTUs are healthy and reporting?		
Whether existing communication via PLCC or OPGW? If PLCC then healthiness of PLCC panels		
In case of OPGW connectivity to the station, whether end equipments are available and functional?		

Healthiness of Protection coupler/Coupling device?		
Tie-breaker healthiness		
Bus-coupler healthiness		
Whether sufficient lighting is available in the switchyard?		
Whether remote operation of MIV is possible?		
Whether online/offline diagnostic tools are available for monitoring generator healthiness?		
DC Supply- Whether two DC sources are available?		
Earthing System in the switchyard: Whether as per IS?		
List of diagnostic tools, testing equipments etc. and whether are present in sufficient quantity?		
Whether firefighting provision is available in the station?		

2. Review of existing settings at substation and recommendations-

3. Recommendation of last protection checking and validation (status of work and pending issues if any)-

4. Disturbance Recorder out available for last 6 tripping's (Y/N) and recommended action-

5. Chronic reason of tripping, if any-

6. Major non-conformity/deficiency observed -

7. Any other specific observations/recommendations:

3RD PARTY PROTECTION AUDIT - 2023

FORMAT FOR DETAILS ABOUT SUBSTATION ELEMENTS AND PROTECTION SETTINGS

GENERAL INFORMATION

1. Name of Sub-station :
2. Voltage level and transformation capacity :
3. Owner of the sub-station :
4. Date of commissioning :
5. Type of Bus- switching scheme :
(voltage level wise)

3RD PARTY PROTECTION AUDIT - 2023

LIST OF AUXILIARY POWER SUPPLIES

SN	Code	Name / Description	DOC
1	DC-1	220/110V Battery Bank - 1	
2	DC-2	220/110V Battery Bank - 2	
3	DC-3	48V Battery Bank - 1	
4	DC-4	48V Battery Bank - 2	
5	AC-1	---KVA, ***/****KV Transformer	
6	AC-2	---KVA, ***/****KV Transformer	
7	DG-1	___KVA DG Set	
8	DG-2	___KVA DG Set	

LIST OF ELEMENTS

SN	Name / Description	DOC
1	Bay 1: _____	
2	Bay 2: _____	
3	Transformer 1 : _____	
4	Transformer 2 : _____	
5	Reactor 1: _____	
6	Reactor 2: _____	
7	Line 1: _____	
8	Line 2: _____	
9	Etc	

3RD PARTY PROTECTION AUDIT - 2023

1.0 AUXILIARIES

1.1 DC Sources

SN	Description	DC - 1	DC - 2	DC - 3	DC - 4
1	Voltage				
2	Checking Cleanliness Battery cell terminals and application of petroleum jelly, if required				
3	No. of Cells Per Bank				
3	Capacity				
4	Electrolyte Level				
5	Sample Checking of Sp. Gravity				
6	Healthiness of Charger				
7	Measurement of Voltage with				
	(a) Charger ON				
	(b) Charger OFF				
8	Positive to Earth				
9	Negative to Earth				
10	Healthiness EF Relay				
11	Discharge Test Capacity				
12	Checking of tightness of VRLA Battery and dusting/ cleaning.				
13	Servicing of Air Conditioners for VRLA Batteries.				

1.2 AC Supply

SN	Description	AC - 1	AC - 2
1	Source of supply		
2	Reliability of Supply		
3	Average trippings per month		

1.3 DG Set

3RD PARTY PROTECTION AUDIT - 2023

SN	Description	DG - 1	DG - 2
1	Make		
2	Rating		
3	Weather on Auto or Manual		
4	Fuel Level		
5	Average Hrs. Run / Month		

2.0 COMMON EQUIPMENTS / ITEMS

SN	Description	Status
1	Bus Bar Protection	
(a)	Bus Voltage	
(b)	Make & Model of Bus Bar relay	
(c)	Status of Healthiness	
(d)	Date of Stability Test	
(e)	Remarks (if any)	
2	Event Logger	
(a)	Make & Model	
(b)	Status of Healthiness	
(c)	Remarks (if any)	
3	Time Synchroniser	
(a)	Make & Model	
(b)	Status of Healthiness	
(c)	Remarks (if any)	
4	Annunciation Scheme	
(a)	Healthiness Annunciation	
(b)	Healthiness Hooter	
(c)	Remarks (if any)	
5	Fire Alarm System	
(a)	Availability	
(b)	Healthiness	
(c)	Remarks (if any)	
6	Fire Fighting System	

3RD PARTY PROTECTION AUDIT - 2023

SN	Description	Status
(a)	Availability	
(b)	Healthiness	
(c)	Remarks (if any)	
7	Earthing System	
(a)	Earth Resistivity Value	
(b)	No. of Pits	Available / Required
(c)	Remarks (if any)	
8	Switchyard Graveling	
(a)	Availability	
(b)	Remarks (if any)	

3.0 BAY

3.1 Bay 1: _____

(a) Lightning Arrestor

SN	Description	Status		
		R-Φ	Y-Φ	B-Φ
1	Make			
2	Rating			
3	Type			
4	Year of Commissioning			
5	Last THRC Test & Values			

(b) Capacitive Voltage Transformer

SN	Description	Core	Status		
			R-Φ	Y-Φ	B-Φ
1	Make	All			
2	Rating	All			
3	Type	All			
4	Year of Comm.	All			
5	Adopted Ratio	Core 1			
		Core 2			

3RD PARTY PROTECTION AUDIT - 2023

		Core 3			
6	Ratio Measured	Core 1			
		Core 2			
		Core 3			
		Core 3			
7	Error Calculated	Core 1			
		Core 2			
		Core 3			
8	Date of Testing	All			

(c) Current Transformer

SN	Description	Core	Status		
			R-Φ	Y-Φ	B-Φ
1	Make	All			
2	Rating	All			
3	Type	All			
4	Year of Comm.	All			
5	Adopted Ratio	Core 1			
		Core 2			
		Core 3			
		Core 4			
		Core 5			
6	Ratio Measured	Core 1			
		Core 2			
		Core 3			
		Core 4			
		Core 5			
7	Error Calculated	Core 1			
		Core 2			
		Core 3			
		Core 4			
		Core 5			
8	Accuracy class of the core used for protection				

3RD PARTY PROTECTION AUDIT - 2023

8	Date of Testing	All			
---	-----------------	-----	--	--	--

(d) Circuit Breaker

SN	Description	Status			
1	Make				
2	Rating				
3	Type				
4	Duty Cycle				
5	No. of Trip & Close Coils	Trip Coil =		Close Coil =	
6	Timing Date & Value	Date:	C =	O =	CO =
7	Healthiness of CB				
8	Pole discrepancy relay available (Y/N)				

4.0 TRANSFORMERS

4.1 Transformer – 1 (mention bay no.)

SN	Description	Status			
1	Make				
2	Rating				
3	Year of Manufacture				
4	Year of Commissioning				
5	Type of Cooling				
6	Type of Earthing				
7	Date of last DGA				
8	Date of last Oil Parameter				
9	Date of last Tan δ & C				
10	Oil Level				
11	Oil Leakage				
12	Rusting / Painting				
13	Differential Protection				

3RD PARTY PROTECTION AUDIT - 2023

SN	Description	Status
(a)	Type	
(b)	Make & Model	
(c)	Healthiness	
(d)	Date of Stability Test	
(e)	Setting	
14	REF Protection	
(a)	Type	
(b)	Make & Model	
(c)	Healthiness	
(d)	Date of Stability Test	
(e)	Setting	
15	Over Flux Protection	
(a)	Type	
(b)	Make & Model	
(c)	Healthiness	
(d)	Date of Last Test	
(e)	Setting	
16	Back Up O/C Protection	
(a)	Type	
(b)	Make & Model	
(c)	Healthiness	
(d)	Date of Last Test	
(e)	Setting	
17	Back Up E/F Protection	
(a)	Type	
(b)	Make & Model	
(c)	Healthiness	
(d)	Date of Last Test	
(e)	Setting	
18	Healthiness Status	
(a)	Buchholz Relay	
(b)	PRV	

3RD PARTY PROTECTION AUDIT - 2023

SN	Description	Status
(c)	OTI	
(d)	WTI	
(e)	MOG	
(f)	Oil Surge Protection	
19.	Communication	
(a)	Integration with RTU	
(b)	Visibility in SCADA	

Fill the above details for every transformer in the substation

5.0 REACTORS

5.1 Reactor – 1: (mention bay no.)

SN	Description	Status
1	Make	
2	Rating	
3	Year of Manufacture	
4	Year of Commissioning	
5	Type of Cooling	
6	Type of Earthing	
7	Date of last DGA	
8	Date of last Oil Parameter	
9	Date of last Tan δ & C	
10	Oil Level	
11	Oil Leakage	
12	Rusting / Painting	
13	Differential Protection	
(a)	Type	
(b)	Make & Model	
(c)	Healthiness	
(d)	Date of Stability Test	
(e)	Setting	

3RD PARTY PROTECTION AUDIT - 2023

SN	Description	Status
14	REF Protection	
(a)	Type	
(b)	Make & Model	
(c)	Healthiness	
(d)	Date of Stability Test	
(e)	Setting	
15	Back Up Impedance	
(a)	Type	
(b)	Make & Model	
(c)	Healthiness	
(d)	Date of Last Test	
(e)	Setting	
18	Healthiness Status	
(a)	Buchholz Relay	
(b)	PRV	
(c)	OTI	
(d)	WTI	
(e)	MOG	
19.	Communication	
(a)	Integration with RTU	
(b)	Visibility in SCADA	

Fill the above details for every Reactor in the substation

6.0 TRANSMISSION LINE

6.1 Line - 1: (for length > 10Km) (mention bay no.)

SN	Description	Status
1	Line Name	
2	Voltage	
3	Length	
4	Type of Conductor	

3RD PARTY PROTECTION AUDIT - 2023

SN	Description	Status
5	Line Configuration	
6	R1 (Ω /Km/Ph.)	
7	X1(Ω /Km/Ph.)	
8	R0 (Ω /Km/Ph.)	
9	X0 (Ω /Km/Ph.)	
10	R0M (Ω /Km/Ph.)	
11	X0M (Ω /Km/Ph.)	
12	No. of Tripping / Year	
13	Infringement Clearance	
14	Accuracy class of CT and PT/CVT	
15	Main - 1 Protection	
(a)	Type	
(b)	Make & Model	
(c)	Healthiness	
(d)	Date of Last Testing	
(e)	Zone 1 Setting	
(f)	Zone 2 Setting	
(g)	Zone 3 Setting	
(h)	Zone 4 Reverse Setting	
(i)	DEF Setting	
16	Main - 2 Protection	
(a)	Type	
(b)	Make & Model	
(c)	Healthiness	
(d)	Date of Last Testing	
(e)	Zone 1 Setting	
(f)	Zone 2 Setting	
(g)	Zone 3 Setting	
(h)	Zone 4 Reverse Setting	
(i)	DEF Setting	
17	Back Up O/C Protection	

3RD PARTY PROTECTION AUDIT - 2023

SN	Description	Status
(a)	Type	
(b)	Make & Model	
(c)	Healthiness	
(d)	Date of Last Testing	
(e)	Setting (I>1)	PS/TS:
(f)	Setting (I>2 and above)	
18	Back Up E/F Protection	
(a)	Type	
(b)	Make & Model	
(c)	Healthiness	
(d)	Date of Last Testing	
(e)	Setting (I>1)	PS/TS:
(f)	Setting (I>2 and above)	
19	Back Up O/C Protection	
(a)	Type	
(b)	Make & Model	
(c)	Healthiness	
(d)	Date of Last Testing	
(e)	Setting	PS/TS:
20	Back Up E/F Protection	
(a)	Type	
(b)	Make & Model	
(c)	Healthiness	
(d)	Date of Last Testing	
(e)	Setting	PS/TS:
21	Over Voltage Stage 1 (applicable for 400kV and above only)	
(a)	Type	
(b)	Make & Model	
(c)	Healthiness	
(d)	Date of Last Testing	
(e)	Setting	
22	Over Voltage Stage 2 (applicable for 400kV and above only)	

3RD PARTY PROTECTION AUDIT - 2023

SN	Description	Status
(a)	Type	
(b)	Make & Model	
(c)	Healthiness	
(d)	Date of Last Testing	
(e)	Setting	
23	Communication and Tele-protection	
I.	PLCC & Prot. Coupler	
(a)	Type	
(b)	Make & Model	
(c)	Healthiness of Carrier	
(d)	Date of Last Testing	
(e)	Carrier inter-trip enabled or not	
II.	OPGW	
(a)	Healthiness of OPGW link	
III.	RTU	
(a)	Integration with RTU	
24	Auto Reclosure Scheme	
(a)	Type	
(b)	Make & Model	
(c)	Healthiness	
(d)	Selected Mode	
(e)	Setting	
(f)	Date of Last Testing	
25	Disturbance Recorder	
(a)	Type	
(b)	Make & Model	
(c)	Healthiness	

6.2 Line - 1: (for length < 10Km and voltage >= 66kV) (mention bay no.)

3RD PARTY PROTECTION AUDIT - 2023

SN	Description	Status
1	Line Name	
2	Voltage	
3	Length	
4	Type of Conductor	
5	Line Configuration	
6	R1 (Ω /Km/Ph.)	
7	X1(Ω /Km/Ph.)	
8	R0 (Ω /Km/Ph.)	
9	X0 (Ω /Km/Ph.)	
10	R0M (Ω /Km/Ph.)	
11	X0M (Ω /Km/Ph.)	
12	No. of Tripping / Year	
13	Infringement Clearance	
14	Accuracy class of CT and PT	
15	Main - 1 Protection	
(a)	Type	
(b)	Make & Model	
(c)	Healthiness	
(d)	Date of Last Testing	
(e)	Differential protection setting	
(f)	Zone 1 Setting	
(g)	Zone 2 Setting	
(h)	Zone 3 Setting	
(i)	Zone 4 Reverse Setting	
16	Main - 2 Protection	
(a)	Type	
(b)	Make & Model	
(c)	Healthiness	
(d)	Date of Last Testing	
(e)	Differential protection	

3RD PARTY PROTECTION AUDIT - 2023

SN	Description	Status
	setting	
(f)	Zone 1 Setting	
(g)	Zone 2 Setting	
(h)	Zone 3 Setting	
(i)	Zone 4 Reverse Setting	
16	Back Up O/C Protection	
(a)	Type	
(b)	Make & Model	
(c)	Healthiness	
(d)	Date of Last Testing	
(e)	Setting (I>1)	PS/TS:
(f)	Setting (I>2 and above)	
17	Back Up E/F Protection	
(a)	Type	
(b)	Make & Model	
(c)	Healthiness	
(d)	Date of Last Testing	
(e)	Setting (I>1)	PS/TS:
(f)	Setting (I>2 and above)	
18	Over Voltage Stage 1 (applicable for 400kV and above only)	
(a)	Type	
(b)	Make & Model	
(c)	Healthiness	
(d)	Date of Last Testing	
(e)	Setting	
19	Over Voltage Stage 2 (applicable for 400kV and above only)	
(a)	Type	
(b)	Make & Model	
(c)	Healthiness	
(d)	Date of Last Testing	
(e)	Setting	
20.	Communication and Tele-protection	

3RD PARTY PROTECTION AUDIT - 2023

SN	Description	Status
I.	PLCC & Prot. Coupler	
(a)	Type	
(b)	Make & Model	
(c)	Healthiness of Carrier	
(d)	Date of Last Testing	
(e)	Carrier inter-trip enabled or not	
II.	OPGW	
(a)	Healthiness of OPGW link	
III.	RTU	
(a)	Integration with RTU	
21	Auto Reclosure Scheme	
(a)	Type	
(b)	Make & Model	
(c)	Healthiness	
(d)	Selected Mode	
(e)	Setting	
(f)	Date of Last Testing	
22	Disturbance Recorder	
(a)	Type	
(b)	Make & Model	
(c)	Healthiness	

Fill the above details for every transmission line in the substation

7.0 BUS BAR protection and LBB (for 220kV and above)

3RD PARTY PROTECTION AUDIT - 2023

SN	Description	Status
1	BUS BAR	
(a)	Type	
(b)	Make & Model	
(c)	Healthiness	
(d)	Setting	
(e)	Duplication BB protection for Main buses of 400kV and above	
(f)	Dedicated CT core for each Bus Bar protection (Y/N)	
2	LBB (local breaker Back up)	
(a)	Type	
(b)	Make & Model	
(c)	Healthiness	
(d)	Setting	

ANNEXURE - 1
THIRD PARTY PROTECTION SYSTEM CHECKING & VALIDATION
TEMPLATE FOR A SUBSTATION

1. INTRODUCTION

- (1) The audit reports, along with action plan for rectification of deficiencies found, if any, shall be submitted to RPC or RLDC within a month of submission of report by auditor.
- (2) The third-party protection system checking shall be carried at site by the designated agency. The agency shall furnish two reports:
 - (a) Preliminary Report: This report shall be prepared on the site and shall be signed by all the parties present.
 - (b) Detailed Report: This report shall be furnished by agency within one month after carrying out detailed analysis.

2. CHECKLIST

- (1) The protection system checklist shall contain information as per this Regulation.
 - (a) General Information (to be provided prior to the checking as well as to be included in final report):
 - (i) Substation name
 - (ii) Name of Owner Utility
 - (iii) Voltage Level (s) or highest voltage level?
 - (iv) Short circuit current rating of all equipment (for all voltage level)
 - (v) Date of commissioning of the substation
 - (vi) Checking and validation date
 - (vii) Record of previous tripping's (in last one year) and details of protection operation
 - (viii) Previous Relay Test Reports

- (ix) Overall single line diagram (SLD)
- (x) AC aux SLD
- (xi) DC aux SLD
- (xii) SAS architecture diagram
- (xiii) SPS scheme implemented (if any)

(b) The preliminary report shall inter-alia contain the following:

TABLE A: FORMAT OF PRELIMINARY REPORT

S. No.	Issues	Remarks
1	Recommendation of last protection checking and validation	Status of works and pending issues if any
2	Review of existing settings at substation	Recommended Action
3	Disturbance Recorder out available for last 6 tripping's (Y/N)	Recommended Action
4	Chronic reason of tripping, if any	Recommended Action
5	Major non-conformity/deficiency observed	Recommended Action

(c) The relay configuration checklist for available power system elements at station:

- (i) Transmission Line
- (ii) Bus Reactor/Line Reactor
- (iii) Inter-connecting Transformer
- (iv) Busbar Protection Relay
- (v) AC auxiliary system
- (vi) DC auxiliary system
- (vii) Communication system
- (viii) Circuit Breaker Details

- (ix) Current Transformer Details
 - (x) Capacitive Voltage Transformers Details
 - (xi) Any other equipment/system relevant for protection system operation
- (d) The minimum set of points on which checking and validation shall be carried out is covered in this clause. The detailed list shall be prepared by checking and validation team in consultation with concerned entity, RLDC and RPC.
- (i) Transmission Line Distance Protection/Differential Protection
 - a. Name and Length of Line
 - b. Whether series compensated or not
 - c. Mode of communication used (PLCC/OPGW)
 - d. Relay Make and Model for Main-I and Main-II
 - e. List of all active protections & settings
 - f. Carrier aided scheme if any
 - g. Status of Power Swing/Out of Step/SOTF/Breaker Failure/Broken Conductor/STUB/Fault Locator/DR/VT fuse fail/Overvoltage Protection/Trip Circuit supervision/Auto-reclose/Load encroachment etc.
 - h. Relay connected to Trip Coil-1 or 2 or both
 - i. CT ratio and PT ratio
 - j. Feed from DC supply-1 or 2
 - k. Connected to dedicated CT core (mention name)
 - l. Other requirements for protection checking and validation
 - (ii) Shunt Reactor & Inter-connecting Transformer Protection
 - a. Whether two groups of protections used (Group A and Group B)
 - b. Do the groups have separate DC sources
-

- c. Relay Make and Model
- d. List of all active protections along with settings
- e. Status of Differential Protection/Restricted Earth Fault Protection/Back-up Directional Overcurrent/Backup Earth fault/ Breaker Failure
- f. Status of Oil Temperature Indicator/Winding Temperature Indicator/Bucholz/Pressure Release Device etc.
- g. Relay connected to Trip Coil-1 or 2 or both
- h. CT ratio and PT ratio
- i. Feed from DC supply-1 or 2
- j. Connected to dedicated CT core (mention name)
- k. Other requirements for protection checking and validation

(iii) Busbar Protection Relay

- a. Busbar and redundant relay make and model
- b. Type of Busbar arrangement
- c. Zones
- d. Dedicated CT core for each busbar protection (Yes/No)
- e. Breaker Failure relay included (Yes/No), if additional then furnish make and model
- f. Trip issued to both Busbar protection in case of enabling
- g. Isolator indication and check relays
- h. Other requirements for protection checking and validation

(iv) AC auxiliary system

- a. Source of AC auxiliary system

- b. Supply changeover between sources (Auto/Manual)
 - c. Diesel generator (DG) details
 - d. Maintenance plan and supply changeover periodicity in DG
 - e. Single Line Diagram
 - f. Other requirements for protection checking and validation
- (v) DC auxiliary system
- a. Type of Batteries (Make, vintage, model)
 - b. Status of battery Charger
 - c. Measured voltage (positive to earth and negative to earth)
 - d. Availability of ground fault detectors
 - e. Protection relays and trip circuits with independent DC sources
 - f. Other requirements for protection checking and validation
 - g. Communication system
 - i. Mode of communication for Main-1 and Main-2 protection
 - ii. Mode of communication for data and speech communication
 - iii. Status of PLCC channels
 - iv. Time synchronization equipment details
 - v. 7OPGW on geographically diversified paths for Main-1 and main-2 relay
 - vi. Other requirements for protection checking and validation
- (vi) Circuit Breaker Details
- a. Details and Status
 - b. Healthiness of Tripping Coil and Trip circuit supervision relay
 - c. Single Pole/Multi pole operation
-

- d. Pole Discrepancy Relay available(Y/N)
- e. Monitoring Devices for checking the dielectric medium
- f. Other requirements for protection checking and validation

(vii) Current Transformer (CT)/Capacitive Voltage Transformer (CVT) Details

- a. CT/CVT ID name and voltage level
- b. CT/CVT core connection details
- c. Accuracy Class
- d. Whether Protection/Metering
- e. CT/CVT ratio available and ratio adopted
- f. Details of last checking and validation of CT/CVT healthiness
- g. Other requirements for protection checking and validation
- h. Other protections: Direction earth fault, negative sequence, over current, over voltage, over frequency, under voltage, under frequency, forward power, reverse power, out of step/power swing, HVDC protection etc.

3. SUMMARY OF CHECKING:

The summary shall specifically mention minimum following points:

- (1) The settings and scheme adopted are in line with agreed protection philosophy or any accepted guidelines (e.g. Ramakrishna guidelines or CBIP manual based).
- (2) The deviations from the RPC protection philosophy, if any and reasons for taking the deviations shall be recorded.
- (3) All the major general deficiency shall be listed in detail along with remedial recommendations.

- (4) The relay settings to be adopted shall be validated with simulation based or EMTP studies and details shall be enclosed in report.
- (5) The cases of protection maloperation shall be analysed from protection indices report furnished by concerned utility, the causes of failure along with corrective actions and recommendations based on the findings shall be noted in the report.

Final Standard Operating Procedure (SOP) to address the Grid Disturbances (GDs)/Grid Incidents (GIs)/any other Protection Trippings

1. Immediately following an event (grid disturbance/incidence as defined in the CEA (Grid Standards) Regulations 2010 and subsequent amendment in the system, the concerned user/entity or SLDC shall inform to the RLDC through voice message.
2. Written flash report shall be submitted to RLDC and SLDC by the concerned user/entity within the time line specified in **Table 8** below, as per the IEGC, 2023.
3. In compliance of IEGC, 2023, All the Users, STU/SLDC are required to furnish the following information in respect of Grid Occurrences(GD/GI) within the time line specified in **Table 8** below, to RLDC/ RPC:
 - (i) First Information Report (FIR)
 - (ii) Event Logger (EL) output
 - (iii)Disturbance Recorder (DR) output
 - (iv)Trip event analysis report-TR (with pre and post fault system conditions)
 - (v) Data Acquisition System (DAS)
4. RLDC shall report the event (grid disturbance or grid incidence) to CEA, RPC and all regional entities within twenty-four (24) hours of receipt of the flash report.
5. After a complete analysis of the event, the user/entity shall submit a detailed report in the case of grid disturbance or grid incidence within one (1) week of the occurrence of event to RLDC and RPC.
6. Based on the above detailed report submitted to RLDC by the entities, RLDC shall Categorize Grid Occurrences into grid incidents (GIs) and grid disturbance (GDs) based on criteria as per the CEA (Grid Standards) Regulations 2010 and subsequent amendment. RLDC shall also submit the Auto Reclosure (A/R) failure events, PLCC related events, any other protection related events to RPCs on monthly basis.
7. RLDCs and NLDC (for events involving more than one region) shall prepare a draft report of each grid disturbance or grid incidence including simulation results and analysis along with associated PMU plots of appropriate resolution, which shall be discussed and finalized at the Protection sub-committee/sub-group of RPC as per the timeline specified in **Table-8** below.

TABLE 8 : REPORT SUBMISSION TIMELINE

Sr. No.	Grid Event* (Classification)	Flash report submission deadline (users/ SLDC)	Disturbance record and station event log submission deadline (users/ SLDC)	Detailed report and data submission deadline (users/ SLDC)	Draft report submission deadline (RLDC/ NLDC)	Discussion in protection committee meeting and final report submission deadline (RPC)
1	GI-1/GI-2	8 hours	24 hours	+7 days	+7 days	+60 days
2	Near miss event	8 hours	24 hours	+7 days	+7 days	+60 days
3	GD-1	8 hours	24 hours	+7 days	+7 days	+60 days
4	GD-2/GD-3	8 hours	24 hours	+7 days	+21 days	+60 days
5	GD-4/GD-5	8 hours	24 hours	+7 days	+30 days	+60 days

^The classification of Grid Disturbance (GD)/Grid Incident (GI) shall be as per the CEA Grid Standards.

(The above table is as per the IEGC 2023)

8. RPCs shall circulate all the GDs, GIs, near miss events, A/R events, PLCC mal-operation events, any other protection related event etc. along with the Agenda for Protection Co-Ordination Sub-Committee (PCSC) of RPCs. PCSC meetings are to be held in every month.
9. The implementation of the recommendations of the final report shall be monitored by the protection sub-committee of the RPC. Tripping portals deployed for reporting of the GDs & GIs on RLDCs portal, shall also have compliances reporting of PCSC recommendations on this portal. NLDC shall disseminate the lessons learnt from each event to all the RPCs for necessary action in the respective regions.
10. Constituents/entities shall furnish the following details to RPCs/RLDCs in respect of all the grid occurrences for analysis:
 - a) Detailed analysis of the events
 - b) SLD or equivalent pictorial representation clearly showing:
 - i. Location of fault with distance
 - ii. Fault details with type & relay indications
 - iii. CT/PT/CVT rating details with location
 - iv. Bus-bar arrangement/ Configuration of feeders and other information related to the ratings of the information required for analysis of the disturbance.
 - v. CB positions (OPEN/ CLOSE) before and after fault
 - vi. Isolator & Earth-switch positions (OPEN/CLOSE)
 - vii. Voltage, frequency & power flows with direction at the time of fault
 - c) Output of Event logger & Disturbance recorder
 - d) Remedial Action(s) taken
 - e) Relay setting details

HVDC Station Disturbance : Any additional data such as HVDC transient fault

record, switchyard equipment and any other relevant station data required for carrying out analysis of an event by RPC, NLDC, RLDC and SLDC shall be furnished by the users including RLDC and SLDC, as the case may be, within forty- eight (48) hours of the request. All users shall also furnish high-resolution analog data from various instruments including power electronic devices like HVDC, FACTS, renewable generation (inverter level or WTG level) on the request of RPCs, NLDC, RLDCs or SLDCs.

Generating Station Disturbance: Generating Station shall furnish high-resolution analog data from various instruments including AVR response, PSS response required for analysis of disturbance.

11. The respective entities (for which the Grid occurrence is placed in the PCSC agenda) shall present the Grid Occurrence which shall cover all related aspects such as:
 - a) Antecedent conditions,
 - b) Bus-configuration,
 - c) Reasons of GD/ GI occurrence,
 - d) Relevant Diagrams showing location of the fault,
 - e) Bus bar arrangement/configuration of feeders and other connected equipment with proper CB positions (OPEN/ CLOSE) at the time of occurrence of the fault,
 - f) Type of protections operated,
 - g) Substantiation of the protections operated by relevant DRs & ELs,
 - h) Reasons for protection systems mal-operation/non-operation,
 - i) Remedial measures taken/ proposed, etc.
12. In respect of failure or Non-operation of A/R events, PLCC mal-operation events, any other protection related event as given in the PCSC agenda the concerned entities, shall furnish the reasons along with remedial action taken to RPCs/RLDCs. The same would be analyzed by the PCSC.
13. In the PCSC meetings, all the GDs, GIs, A/R non-operation/mal-operation, PLCC mal-operations, other protection related trippings/events as circulated in the agenda shall be analyzed in detail by the PCSC forum and conclude the suitable recommendations to avoid the recurrence of such incidents in the future.
14. The action plan by the entities shall be furnished to RPC for implementation of the PCSC recommendations along with the timelines.
15. The implementation of the PCSC recommendations shall be followed up in the monthly PCSC meetings of RPC.
16. When grid disturbances or grid incidents occurred at major/critical substations and at substations that affected critical/essential/strategic loads, a **Protection System Analysis Group (PSAG)** shall be constituted consisting of the members from RPC, NLDC, RLDC, PGCIL, a Protection Expert from the region along with the Entity under whose jurisdiction GD/GI occurred to analyze the GD/GI in detail by visiting the respective substation/substations physically and conducting the meetings. PSAG would finalize the remedial actions and recommendations after deliberations and detailed analysis. The progress of implementation of the PSAG shall be followed up in the monthly PCSC Meetings.
17. In case any user/entity fails to undertake remedial action identified by the RPC within the specified timelines as decided by PCSC of RPC, the concerned RPC may approach the Commission with all relevant details for suitable directions.

18. A date depository of the event as maintained by the RLDC shall be accessible to every entity and the entity shall upload all the relevant documents on the RLDC portal of trippings.

North East Regional Power Committee

PROTECTION PROTOCOL OF NORTH EAST REGION

Prepared in Compliance to

Clause 12(2) and Clause 13 of Central Electricity Regulatory
Commission Indian Electricity Grid Code Regulations, 2023

By

NERPC Secretariat

October 2023

(Effective from 01.10.2023)

Contents

- 1. Background**
- 2. Applicability**
- 3. Definitions**
- 4. General Philosophy of Protection System**
- 5. Protection Schemes**
- 6. Protection Settings & Coordination**
- 7. Disturbance Monitoring, Analysis and Reporting**
- 8. Compliance Monitoring**

PROTECTION PROTOCOL OF NORTH EAST REGION

1. Background

1.1. The Protection Protocol of North East region is prepared in accordance with Clauses 12(2) & 13 of the Indian Electricity Grid Code, 2023 (IEGC 2023) notified by the Central Electricity Regulatory Commission.

1.1.1. The clause 12(2) of the IEGC 2023:

“There shall be a uniform protection protocol for the users of the grid:

- a) for proper co-ordination of protection system in order to protect the equipment/system from abnormal operating conditions, isolate the faulty equipment and avoid unintended operation of protection system;*
- b) to have a repository of protection system, settings and events at regional level;*
- c) specifying timelines for submission of data;*
- d) to ensure healthiness of recording equipment including triggering criteria and time synchronization; and*
- e) to provide for periodic audit of protection system.”*

1.1.2. The clause 13 of the IEGC 2023:

“13. Protection protocol

- (1) All users connected to the integrated grid shall provide and maintain effective protection system having reliability, selectivity, speed and sensitivity to isolate faulty section and protect element(s) as per the CEA Technical Standards for Construction, the CEA Technical Standards for Connectivity, the CEA (Grid Standards) Regulations, 2010, the CEA Technical Standards for Communication and any other applicable CEA Standards specified from time to time.*
- (2) Back-up protection system shall be provided to protect an element in the event of failure of the primary protection system.*
- (3) RPC shall develop the protection protocol and revise the same, after review from time to time, in consultation with the stakeholders in the concerned region, and in doing so shall be guided by the principle that minimum electrical protection functions for equipment connected with the grid shall be provided as per the*

CEA Technical Standards for Construction, the CEA Technical Standards for Connectivity, the CEA Technical Standards for Communication, the CEA (Grid Standards) Regulations, 2010, the CEA (Measures relating to Safety and Electric Supply) Regulations, 2010, and any other CEA standards specified from time to time.

(4) The protection protocol in a particular system may vary depending upon operational experience. Changes in protection protocol, as and when required, shall be carried out after deliberation and approval of the concerned RPC.

(5) Violation of the protection protocol of the region shall be brought to the notice of concerned RPC by the concerned RLDC or SLDC, as the case may be.”

1.2. The Protection Protocol of North Eastern Region stipulates General Protection Philosophy of Protection System, Protection Schemes for Generators & various Transmission Elements in Power System, Protection Settings & their Coordination among entities, Disturbance Monitoring, Analysis and Reporting, Time Synchronization of Protection Systems, Protection Audit Plan, Performance of Protection Systems & Compliance Monitoring.

2. Applicability

The Protection Protocol of North Eastern Region shall be applicable to all North Eastern Regional entities, State/Central/Private Generating Companies/ Generating Stations including REGs, RHGS, integrated RE with Pumped Storage Plant (PSP), SLDCs, NERLDC, CTU, STUs, Transmission Licensees and NERPC.

3. Definitions

Words and expressions used in this Protection Protocol are defined in the Act or any other regulations specified by the Central Commission or Central Electricity Authority shall, unless the context otherwise requires, have the meanings assigned to them under the Act or other regulations specified by the Central Commission, as the case may be.

4. General Philosophy of Protection System

4.1. Protection philosophy shall be in accordance with below mentioned objectives, design criteria and other details. However, protection design in a particular system may vary depending upon judgment and experience in the broad contours of the protection philosophy. Consideration must also be given to the type of equipment to be protected as well as the importance of this equipment to the system. Further, protection must not be defeated by the failure of a single component.

4.1.1. Objectives:

The basic objectives of any protection schemes should be to:

- (i) Automatically isolate the faulty element.
- (ii) Mitigate the effect of short circuit and other abnormal conditions in minimum possible time and area.
- (iii) Indicate the location and type of fault and
- (iv) Provide effective tools to analyse the fault and decide remedial measures.

4.1.2. Design Criteria:

To accomplish the above objectives, the four design criteria for protection that should be considered are:

- (i) fault clearance time/speed;
- (ii) selectivity;
- (iii) sensitivity and
- (iv) reliability (dependability and security)

4.1.2.1. **Fault clearance time/speed:** In order to minimize the effect on customers and maintain system stability, Fault clearance time shall be as per CEA Grid Standard Regulations 2010, as amended to date.

4.1.2.2. **Selectivity:** To ensure Selectivity, coordination shall be ensured with the adjacent protection schemes including breaker failure, transformer downstream relays, generator protection and station auxiliary protection.

4.1.2.3. **Sensitivity:** To ensure Sensitivity, the settings must be investigated to determine that they will perform correctly for the minimum fault current envisaged in the system, yet remain stable during transients and power swings from which the system can recover.

4.1.2.4. **Reliability:** To ensure Reliability, two independent auxiliary direct current-supplies shall be provided for Main-I and Main-II relays. The Main-I and Main-II relays should be from two different makes or operating with different algorithm. The CB's shall have two independent trip coils and two independent trip circuits. Each protection device should trip at least one of them by independent auxiliary DC- supplies.

4.1.2.5. **Security:** To ensure Security, the protection shouldn't limit the maximum transmission capacity of the element. Distance protection in particular could

cause spurious tripping due to specific grid conditions, in case of high load operation. Therefore, any special topologies must be known and considered for protection parameterization. For parallel Over Head Lines it is necessary to consider the rapid increase of load current in the healthy line when the faulty line trips and the protection operation must allow such conditions. The load encroachment detection function of the relays must be used, when the highest distance zone resistance reach conflicts with the maximum transmitted load on the protected element.

- 4.2. All generating units shall have standard protection system to protect the units not only from faults within the units and within the Station but also from faults in sub-stations and transmission lines.
- 4.3. The generator, generator transformer, unit auxiliary transformer shall be provided with protection systems connected to two independent channels or groups, such that one channel or group shall always be available for any type of fault in the generator and these transformers;
- 4.4. Protection relays shall be configured in such a way that digital input points shall not pick up due to stray voltages.
- 4.5. Protective relays shall be used to detect electrical faults, to activate the alarms and disconnect or shut down the faulted apparatus to provide for safety of personnel, equipment and system.
- 4.6. Electrical faults shall be detected by the protective relays arranged in overlapping zones of protection.
- 4.7. The protection relays for the generators, motors, transformers and the transmission lines shall generally be of numerical type.
- 4.8. The protection system for 400kV and higher voltage transmission line and the line compensating equipment shall have one hundred percent back up communication channels i.e. two channels for tele- protection in addition to one channel for speech plus data for each direction. Provided that, for 220 kV, 132 kV, 110 kV and 66 kV lines, the channel for speech plus data can also be used for tele-protection
- 4.9. All relays used shall be suitable for operation with CTs secondary rated for one ampere or five amperes as per relevant Indian Standards or International Electrotechnical Commission or Institute of Electrical and Electronics Engineers standards.
- 4.10. Relevant Indian Standards or International Electrotechnical Commission or Institute of Electrical and Electronics Engineers standards shall be applied for protection of generators, transformers and motors.

5. Protection Schemes

The electrical protection functions for equipment connected with the grid shall be provided as per the Central Electricity Authority (Technical Standards for Construction of Electrical Plants and Electric Lines) Regulations 2022 amended to date, the CEA (Technical Standards for connectivity to the Grid) Regulations 2007 amended to date, the CEA

(Technical Standards for Communication System in Power System Operation) Regulations 2020 amended to date, the CEA (Grid Standards) Regulations 2010 amended to date, the CEA (Measures relating to Safety and Electric Supply) Regulations 2023 amended to date, and any other CEA standards specified from time to time.

5.1. Thermal Generating Units

The electrical protection functions for generator, generator transformer, unit auxiliary transformer and station transformer shall be provided in accordance with but not limited to the list given in **SCHEDULE-I** of CEA (Technical Standards for Construction of Electrical Plants and Electric Lines) Regulations 2022 amended to date.

For the generating units with a rating of more than one hundred megawatt, protection system shall be configured into two independent sets of protection (Group A and B) acting on two independent sets of trip coil fed from independent

DC supplies, using separate sets of instrument transformers, and segregated cables of current transformers and voltage transformers

5.2. Hydro Generating Units

The protection functions for Generator, Excitation Transformer, Generator Transformer, Generator and Generator Transformer, Unit Auxiliary Transformer, and Station Auxiliary Transformer shall be provided in accordance with but not limited to the list given in **SCHEDULE-IV** of CEA (Technical Standards for Construction of Electrical Plants and Electric Lines) Regulations 2022 amended to date except for variable speed units which will have specialized protection functions.

5.3. REGs/RHGS/BESS

Protection Schemes for Renewable Energy (RE) Power Plants of Solar power generation, Wind power generation, Battery Energy Storage System (BESS) and Hybrid of these connected with grid at voltage level above 650 volts shall be in accordance with the Central Electricity Authority (Technical Standards for Construction of Renewable Energy Power Plants) Regulations, 2023 from the date as & when these regulations are notified (Presently the finalization of these Standards by CEA is under progress).

5.4. Substations & Transmission System Elements

5.4.1. All major protection relays for the Voltage levels 66 kV and above shall be of numerical type.

5.4.2. Grouping of Protection systems for the voltage level 66 kV and above:

- i. The protection circuits and relays shall be electrically and physically segregated into two groups each being independent and capable of providing uninterrupted protection even in the event of one of the protection group fails or taken out for maintenance.
- ii. Interconnection between these two groups shall not generally be attempted.

However, such interconnection shall be kept to the bare minimum, if found absolutely necessary.

5.4.3. The protections required in respect of transmission lines, transformers, reactors and bus bars but not limited to shall be in accordance with **SCHEDULE-V** of CEA (Technical Standards for Construction of Electrical Plants and Electric Lines) Regulations 2022 amended to date.

5.4.4. Bus Bar Protection and Local Breaker Backup Protection (breaker failure protection):

- i) Bus bar protection and local breaker backup protection shall be provided in 220 kV and higher voltage interconnecting sub- stations as well as in all generating station switchyards.
- ii) Duplication of bus bar protection shall be done for all main buses of 400kV and above voltage class.
- iii) The bus bar protection scheme shall be centralized or distributed type and have provision for planned future expansion.

5.5. HVDC Terminals/ Stations

5.5.1. Classical HVDC Terminals/ Stations

- i) HVDC system protection shall consist of two parts:

(A) AC side protection:

AC side protection function shall cover the zone for converter transformer, AC filters, shunt capacitors, shunt reactors, and bus bars. These protections shall generally follow the same philosophy as in a typical substation i.e. detection of fault by relay and tripping of circuit breaker.

(B) DC side protection:

DC side protection shall cover the zones consisting of the valve hall, DC switchyard including smoothing reactor and DC filters, DC line, DMR line / electrode line and ground electrode. The protection equipment shall be designed to be fail safe and shall ensure high security to avoid mal-operation/ unwanted shutdown due to protection equipment failures.

- ii) Following a DC Line fault, the HVDC System shall have the facility to restart, one or more times, the faulted pole at a variable pre-selected DC voltage level(s), not below 80% of the nominal voltage rating. The DC transmission system shall be capable of recovery in a controlled and stable manner without commutation failures during recovery following ac and dc system faults. The post fault power order shall be equal to the pre-fault power order unless AC/ DC systems dictate otherwise.
- iii) Protection system required in respect of Classical HVDC Terminals/ Stations but not limited to shall be in accordance with 13 (b) of Part A of **SCHEDULE-VI** of CEA (Technical Standards for Construction of Electrical Plants and Electric Lines)

Regulations 2022 amended to date.

- iv) Software based controls and protection shall be used to permit flexibility in effecting modifications. Protection and controls shall be duplicated for reliability. The control & protection shall provide fast controllability of the HVDC system.

5.5.2. Voltage Source Converter (VSC) based HVDC Terminals/Stations

- i) The protection equipment shall be designed to be fail-safe and shall ensure high security to avoid mal-operation/ unwanted shutdown due to protection equipment failures.
- ii) Protection system required in respect of Voltage Source Converter (VSC) based HVDC Terminals/ Stations but not limited to shall be in accordance with 8 (b) of Part B of **SCHEDULE-VI** of CEA (Technical Standards for Construction of Electrical Plants and Electric Lines) Regulations 2022 amended to date.
- iii) Software based controls and protection shall be used to permit flexibility in effecting modifications. Protection and controls shall be duplicated for reliability. Protection shall be provided by numerical relays to suit the requirement of the HVDC system.

5.6. Philosophy of Transmission Line Protection

5.6.1. Transmission circuit construction can be considered in three main categories viz.: Overhead construction, Underground cable construction and Composite (overhead plus underground) construction.

5.6.2. Transmission circuit Main protection is required to provide primary protection for the line and clear all type of faults on it within shortest possible time with reliability, selectivity and sensitivity. Transmission circuit back-up protection shall cater for failure of any main protection system to clear any fault that it is expected to clear. A protection function that offers back-up for most faults may also provide main protection for some fault conditions. Combinations of main and back-up protection systems should be used to address the main and application specific requirements for transmission circuits.

5.6.3. Protection system of Transmission line shall have following features:

- i) The systems applied must be capable of detecting all types of faults, including maximum expected arc resistance that may occur at any location on the protected line.
- ii) The protection should be set not to trip under system transient conditions, which are not short circuits. Conversely where the short circuit current is low due to local grid conditions (weak network) or due to high resistance of the arc, this must be taken into consideration to trip the relay by using the most appropriate criterion, without jeopardizing the unwanted tripping during heavy load conditions.
- iii) The design and settings of the transmission line protection systems must be such that, with high probability, operation will not occur for faults

external to the line or under non-fault conditions.

- iv) Distance relay shall be capable to protect the series compensated lines from voltage inversion, current inversion phenomenon. Special measures must be taken to guard against these phenomenon
- v) On 400 & 220kV lines, 2 Main Protections (main I and Main II), back up Earth Fault protections alone to be provided. No Over current protection to be applied.
- vi) The Main-I and Main-II protection shall be numerical relays of different makes or employ different fault detection algorithm. They should be carrier aided and powered by two separate DC sources
- vii) On 132kV and lower voltage lines, only one Main protection and Back up protection by IDMT O/C and E/F to be applied
- viii) For lines less than ten kilometers (any voltage level 132kV and above), cables, and combination of cable and overhead line, Differential protection (segregated phase type) has to be provided as Primary protection with built-in distance protection as back up protection. Zone-I protection feature shall get automatically enabled in case of communication failure observed by the differential relay.

5.6.4. Philosophy for protection settings:

Sl. No.	Protection setting		Reach and time
1.	Distance protection	Zone 1	80% of the protected line, instantaneous
		Zone 2	120% (150% in case of DC line). Time delay: 350msec (generally) and 500msec in case 20% of the protected line is greater than 60% of the shortest line at remote end
		Zone 3	120% of the protected line + 100% of the longest line emanating from the far end bus bar. Time delay: 800msec
		Zone 4 (reverse fault)	<ul style="list-style-type: none"> • For lines < 100 km 10% of the protected line or 50% of adjacent shortest line, whichever is lower <ul style="list-style-type: none"> • For lines > 100 km 20% of the protected line or 50% of adjacent shortest line, whichever is lower Time delay: 500msec
2.	Line differential protection		Primary protection for lines less than 10KM. Time delay: instantaneous
3.	LBB protection and Bus Bar Protection (for 220kV and above as well as all Generating stations)		LBB time delay: 200msec, LBB Current sensor $I > 20\% I_n$ Bus bar protection time delay: instantaneous
4.	O/C back up protection (for 132kV and below)	IDMT	<u>For $I > 1$</u> $I_b = 150\%$ of current rating of the line. Time delay: to be coordinated with Z2 for three phase fault at remote bus (500msec). Forward directional <u>For $I > 2$ (and above)</u> Generally disabled unless decided otherwise by NERPC for special scenario
5.	E/F backup protection (for 132kV and above lines)	IDMT	<u>For $I_n > 1$</u> $I_b = 20\%$ of current rating of the line. Time delay: to be coordinated with Z3 for single phase to ground fault at remote bus (900msec). Forward directional <u>For $I_n > 2$ (and above)</u> Generally disabled unless decided otherwise by NERPC for special scenario
6.	Broken conductor protection (alarm only)		Negative Sequence current to Positive Sequence current ratio more than 0.2 ($I_2/I_1 \geq 0.2$) Only for alarm: Time delay = 3-5 sec
6.	Allowable Load impedance encroachment		$I_{max} = 150\%$ of current rating of line $V_{min} = 0.85pu$ (85%) 30 degrees for load blinder
7.	Power swing Blocking function		Block all zones except Zone-1 or Block all zones and trip with OOS function
8	Carrier Aided Protection		To be provided on 132kV and above lines (PLCC or DTPC)

9.	Single/Three phase auto reclosure	To be provided on 132kV and above lines on Zone 1 or differential relay operation Dead time = 1.0s. Reclaim time = 25.0s	
10.	Over voltage protection (two stage, for 400kV and above only)	Stg I*	V>110%. Time delay: 5seconds
		Stg II	V>140%. Time delay: 100msec
11.	Carrier Aided Protection	Mandatory for Distance protection	

*** The OVR grading, Voltage and Time graded, for the Stage-I over voltage protection shall be as recommended by NERPC/NERLDC**

6. Protection Settings & Coordination

The purpose is to ensure system protection is coordinated among the grid connected entities. The Protection systems coordination comprises the following:

- i) Each Transmission licensee shall coordinate its Protection System schemes with concerned transmission system, sub-transmission system and generators.
- ii) Each Generating Company shall coordinate its Protection System schemes with concerned transmission system and station auxiliaries.
- iii) Utilities may seek assistance of NERPC and NERLDC also for ensuring coordination
- iv) Each Transmission Licensee and Generation Company shall be responsible for settings calculations for protection of elements under its ownership. It shall be the responsibility of the respective asset owner to obtain the inputs (adjacent line settings, infeed values etc.) from STU/Generating Company/ Transmission Licensee necessary for calculation of the settings.
- v) STU/Generating Company/Transmission Licensee shall provide the infeed values/latest network model to the requesting entity, within one week of receipt of such a request from the entity.
- vi) Each user, for voltage levels 132kV and above, shall submit the protection settings as per the format prescribed, along with the calculation sheets, co-ordination study reports and input data, in advance, to NERPC/NERLDC for every new/modified element to be commissioned. The mentioned information shall be submitted to the NERPC/NERLDC fifteen days in advance for all the elements proposed to be commissioned. The user has to obtain relay setting approval by NERPC before FTC can be provided.
- vii) FTC will only be issued after complete relay setting coordination is ensured by the applicant. It is the responsibility of the utility, which is applying for the FTC of any element, to coordinate with concerned utilities to ensure that they complete the relay coordination before applying for FTC
- viii) The PCCM of NERPC shall review the settings to ensure that they are properly coordinated with adjacent system and comply with the existing guidelines. The forum may issue proper directions to utilities in this regard.
- ix) All users connected to the grid shall obtain approval of the NERPC for any revision in settings, and implementation of new protection system
- x) All users connected to the grid shall ensure correct and appropriate settings of protection as specified by the NERPC and intimate to the NERPC about the changes implemented in protection system or protection settings within a fortnight of such changes
- xi) In case of failure of a protective relay or equipment failure, the Generating Company and Transmission Licensee shall inform appropriate LDC/NERLDC/NERPC. The

Generating Company and Transmission Licensee shall take corrective action as soon as possible.

- xii) NERPC in consultation with the NERLDC & Regional entities shall undertake review of the protection settings, assess the requirement of revisions in protection settings and revise protection settings, from time to time and at least once in a year. The necessary studies in this regard shall be carried out by the NERPC & NERLDC. The modifications/changes, if any, in protection settings shall be advised to the respective users and STUs.
- xiii) NERPC shall maintain a centralized database and update the same on periodic basis in respect of their respective region containing details of relay settings for grid elements connected to 220 kV and above. NERLDC also shall maintain such database.
- xiv) Respective entities are responsible for ensuring to make available the implemented protection settings in the centralized database before obtaining FTC.
- xv) If System Protection Schemes (SPS) is recommended to be implemented by the appropriate forum/Sub-Committee of NERPC on account of operational & system constraints, the same shall be implemented by the concerned Transmission licensee/Generating Company/Entities within the specified timelines.

7. Disturbance Monitoring, Analysis and Reporting

The Purpose is to ensure that adequate disturbance data is available to facilitate Grid event analysis. The analysis of power system disturbances is an important function that monitors the performance of protection system, which can provide information related to correct behaviour of the system, adoption of safe operating limits, isolation of incipient faults,

7.1. The Disturbance Monitoring Requirements include the following:

- i) Each line or transformer or reactor or any other bay shall be provided with facility for disturbance recording, event logging and Time Synchronizing Equipment.
- ii) Each line shall be provided with facility for distance to fault locator
- iii) Each Transmission Licensee/Generating Company/Users shall provide Disturbance recording capability for the following Elements at facilities:
 - All transmission lines (Each line shall be provided with facility for distance to fault locator)
 - Autotransformers or phase-shifters connected to busses.
 - Shunt capacitors, shunt reactors.
 - Individual generator line interconnections.
 - Dynamic VAR Devices.
 - HVDC terminals.
 - Bus Bars
- iv) The Disturbance recording feature shall be enabled and configured in all the numerical relays installed. Disturbance recording system shall have minimum recording time of 3 seconds (0.5 seconds for pre-fault and 2.5 seconds for post fault).
- v) Each Transmission Licensee and Generating Company shall record for Faults, sufficient electrical quantities for each monitored Element to determine the following:
 - Three phase-to-neutral voltages. (Common bus-side/line side voltages may be used for lines.)
 - Three phase currents and neutral currents.
 - Polarizing currents and voltages, if used (As applicable).
 - Frequency (As applicable).
 - Real and reactive power (As applicable).

The Minimum parameters to be monitored in the Fault record shall be specified by the PCC of NERPC.

- vi) Each Transmission Licensee and Generating Company shall provide Disturbance recording with the following capabilities:

- The Disturbance recorders shall have time synchronization and a standard format for recording analogue and digital signals (DR labels to be standardized as per the Report of FOLD Working Group - 3 on DR Parameter Standardization). The data files shall be capable of being viewed, read, and analyzed with a generic COMTRADE analysis tool as per the latest revision of IEEE Standard C37.111.
 - Each Fault record duration and the trigger timing shall be settable and set for a minimum 3 second duration including 0.5 seconds for pre-fault and 2.5 seconds for post fault
 - Each Fault recorder shall have sampling frequency of 1 kHz or better.
 - Each Fault recorder shall be set to trigger for at least the following:
Internal protection trip signals, external trigger input and additional triggers may be assigned as necessary.
- vii) Each Transmission Licensee and Generating Company shall keep the recording instruments (disturbance recorder and event logger) in proper working condition and shall establish a maintenance and testing program for Disturbance Recorder (DR) that includes
- Maintenance and testing intervals and their basis.
 - Summary of maintenance and testing procedures.
 - Monthly verification of communication channels used for accessing records remotely (if the entity relies on remote access and the channel is not monitored to a control centre staffed around the clock, 24 hours a day, 7 days a week (24/7)).
 - Monthly verification of time synchronization (if the loss of time synchronization is not monitored to a 24/7 control centre).
 - Monthly verification of active analog quantities.
 - A requirement to return failed units to service within 90 days. If a Disturbance Recorder (DR) will be out of service for greater than 90 days, the Transmission Licensee and Generating Company shall keep a record of efforts aimed at restoring the DR to service.
- viii) The time synchronization of the disturbance recorders shall be corroborated with the PMU data or SCADA event loggers by NERLDC. NERLDC shall list out for Disturbance recorders which are non-compliant for discussion in PCC meetings of NERPC.
- ix) Each Transmission Licensee and Generating Company shall submit the data files to the NERLDC conforming to the following format requirements:
- The data files shall be submitted in COMTRADE and PDF format.
 - File shall have contained the name of the Relay, name of the Bay, station

name, date, time resolved to milliseconds, event point name, status.

The DR archives shall be retained for a period of three years.

- x) A separate work-station PC, powered through UPS (Uninterrupted Power Supply) shall be identified with access to all the relays for extraction of DR. Auto-Download facility shall be established for automatic extraction of the DR files to a location on the work- station PC.

xi) Time Synchronization Equipment

- a) Time Synchronizing Equipment complete with antenna, all cables and processing equipment shall be provided to receive synchronizing pulse through Global Positioning System or Indian Regional Navigation Satellite System Navic compatible for synchronization of event logger, disturbance recorder, Phasor Measurement Units, and Supervisory Control and Data Acquisition System or Substation Automation System.
- b) Each substation shall have time synch equipment to synchronize all the numerical relays installed. Before any extension work, the capability of the existing Time-sync equipment shall be reviewed to ensure the synchronization of upcoming numerical relays.
- c) The status of healthiness of the time-sync device shall be wired as “Alarm” to SCADA and as an “Event” to Event Logger.
- d) The time synch status of all the installed numerical relays and event logger shall be monitored monthly and recorded. The Monthly records for relays not in time-sync shall be reported to NERLDC and NERPC. This record shall be archived for a period of three years by each concerned agency.
- e) Remedial action shall be taken by the concerned substation/ Protection department immediately to make the relays in time synchronization with reference to external time source.
- f) All the new Grid elements/Bay extension shall have accurate and precise Time synchronization equipment.

7.2. Disturbance Analysis and Reporting

- i) Immediately following an event (grid disturbance or grid incidence as defined in the CEA Grid Standards) in the system, the concerned user or SLDC shall inform NERLDC through voice message.
- ii) Written flash report shall be submitted to NERLDC and appropriate SLDC by the concerned Transmission Licensee/Generating Company/User within eight (8) hours from Grid event.
- iii) Disturbance Recorder (DR), station Event Logger (EL), Data Acquisition System (DAS) shall be submitted by the respective Transmission licensee and Generating Company within twenty-four (24) hours from Grid event. These records shall be uploaded by the respective Transmission licensee and Generating Company in the

Web Based Tripping Portal of NERLDC.

- iv) NERLDC shall classify the grid incidents and grid disturbances according to CEA (Grid Standards) Regulations, amended to date. NERLDC shall report the event (grid disturbance or grid incidence) to CEA, NERPC and all regional entities within twenty-four (24) hours of receipt of the flash report.
- v) After a complete analysis of the event, the Transmission licensee and Generating Company/User shall submit a detailed report in the case of grid disturbance or grid incidence within one (1) week of the occurrence of event to NERLDC and NERPC.
- vi) NERLDC shall prepare a draft report of each grid disturbance or grid incidence including simulation results and analysis which shall be discussed and finalized in the PCC meetings of NERPC as per the timeline specified in Table below.

Sl. No	Grid Event (GD/GI Classification as per the CEA Grid Standards)	Flash report submission deadline (Users/ SLDC)	Disturbance record and station event log submission deadline by Users/ SLDC)	Detailed report and data submission deadline by Users/ SLDC)	Draft report submission deadline by NERLDC	Discussion in PCC and final report submission deadline by NERPC
1	GI-1/GI-2	8 hours	24 hours	+7 days	+7 days	+60 days
2	Near miss event	8 hours	24 hours	+7 days	+7 days	+60 days
3	GD-1	8 hours	24 hours	+7 days	+7 days	+60 days
4	GD-2/GD-3	8 hours	24 hours	+7 days	+21 days	+60 days
5	GD-4/GD-5	8 hours	24 hours	+7 days	+30 days	+60 days

- vii) The analysis reports submitted by NERLDC shall be discussed in the Protection Coordination Sub-Committee (PCC) meetings of the NERPC. The PCC shall identify the lessons learnt during the events being discussed. The PCC shall scrutinize the correctness of operation of subject protection systems put in place by the concerned Constituents and the final analysis report along with the recommendations shall be concluded. It shall also recommend the appropriate remedial measures for system improvement.
- viii) The implementation of the recommendations of the final report shall be monitored by the PCC of NERPC.
- ix) Any additional data such as
 - Single line diagram (SLD)
 - Protection relay settings,
 - HVDC transient fault record,
 - Location of fault with distance
 - Fault details with type & relay indications

- CT/PT/CVT rating details with location
- Bus-bar arrangement/ Configuration of feeders
- CB positions (OPEN/ CLOSE) at the time of fault
- Isolator & Earth-switch positions (OPEN/CLOSE)
- Voltage, frequency & power flows with direction at the time of fault
- DR&EL records
- switchyard equipment

and any other relevant station data required for carrying out analysis of an event by NERPC, NERLDC and concerned SLDC shall be furnished by the Users including NERLDC and respective SLDC, as the case may be, within forty- eight (48) hours of the request. All Users shall also furnish high-resolution analog data from various instruments including power electronic devices like HVDC, FACTS, renewable generation (inverter level or WTG level) on the request of NERPCs, NLDC, NERLDCs or SLDCs.

- x) Triggering of STATCOM, TCSC, HVDC run-back, HVDC power oscillation damping, generating station power system stabilizer and any other controller system during any event in the grid shall be reported to the NERLDC and NERPC if connected to ISTS and to the concerned SLDC if connected to an intra-state system. The transient fault records and event logger data shall be submitted to the NERLDC or concerned SLDC within 24 hours of the occurrence of the incident. Generating stations shall submit 1 second resolution active power and reactive power data recorded during oscillations to NERLDC or concerned SLDC within 24hours of the occurrence of the oscillations.
- xi) A monthly report on events of unintended operation or non-operation of the protection system shall be prepared and submitted by each user/owner of important elements in the regional grid, as identified by the appropriate forum of NERPC including those in the State grids that are critical for regional grid operation to NERPC and NERLDC within the first week of the subsequent month.
- xii) The detailed analysis reports shall be archived periodically. The archive shall be retained for a period of three years by each concerned agency.

8. Compliance Monitoring

- 8.1. The Protection Protocol of NER shall be reviewed as and when required, in consultation with the stakeholders of the North Eastern Region.
- 8.2. Violation of the Protection Protocol of the North Eastern Region shall be brought to the notice of NERPC by the NERLDC or concerned SLDC, as the case may be.
- 8.3. In case any User/Entity fails to comply with the Protection Protocol or fails to undertake remedial action identified by the PCC of NERPC within the specified timelines, the NERPC would approach the Commission with all relevant details for suitable directions.

SCHEDULE- I

[See sub-regulation (10) of regulation 10]

List of Electrical Protection Functions for Thermal Generating Units

1. Generator

Sl. No.	Protection Function	Remarks
(a)	Generator differential protection (87G)	
(b)	100% stator earth fault protection (64G)	For units of 100 MW and above.
(c)	95% stator earth fault protection (64G1)	For units less than 100 MW.
(d)	Standby stator earth fault protection (64G2)	
(e)	Inter-turn fault protection (87TG)	Applicable where split winding in Stator is provided and if six terminals are available.
(f)	Loss of field protection (40G)	To be duplicated for units of 500 MW and above.
(g)	Negative phase sequence current protection (46G)	
(h)	Low-forward power and Reverse power interlock for steam turbine generator (37/ 32G)	Preferably 3-phase power relays shall be provided. Both the relays shall be duplicated for units of 500 MW and above.
(i)	Rotor earth fault protection - two stages (64F1/F2)	
(j)	Definite time over-voltage protection (59G)	
(k)	Generator under frequency protection (81G)	
(l)	Over-fluxing protection for generator (99G)	To be provided for units of 500 MW and above in duplicate.
(m)	Overload protection for generator (51G)	
(n)	Back- up impedance protection, 3 pole (21G)	
(o)	Overheating (winding and/ or bearing) (49G)	Alarm only.
(p)	Instantaneous and time delayed over current protection on high voltage side of excitation transformer (51)	
(q)	Generator pole slipping protection (98G)	
(r)	Accidental back energisation protection (50GDM)	
(s)	Generator circuit breaker failure protection (50ZGCB)	To be provided for GCB scheme only.

Note: In case digital multifunctional generator protection system is provided, the protection systems for generator shall be duplicated for units of one hundred mega watt and above. Each MGPS shall preferably be provided with individual inputs from CTs and VTs and connected to the independent set of hand-reset trip relays, such that one set is always available in case of testing and mal-operation of the other set. If the MGPS does not include any protection mentioned in the table above, separate discrete protection shall be provided for the same. The MGPS shall preferably have continuous self-monitoring and testing facilities.

2. Generator Transformer

Sl. No.	Protection Function	Remarks
(a)	Overall differential protection (87OA)	
(b)	Generator transformer differential protection (87GT) for single phase bank	
(c)	Restricted earth fault protection for generator transformer (87NGT)	
(d)	Over head line connection differential protection (87L)	For 3 single phase banks, if 87L

		includes HV winding, separate 87NGT is not mandatory.
(e)	Back- up earth fault protection on generator transformer HV neutral (51NGT)	
(f)	Over-fluxing protection for generator transformer (99GT)	To be duplicated for units of 500 MW and above.
(g)	Back- up non-directional over-current protection in all phases on HV side of generator transformer (51GT)	
(h)	Generator transformer oil temperature indicator (OTI) trip (49Q) and winding temperature indicator (WTI) trip (49T)	
(i)	Generator transformer Buchholz (63), Pressure relief valve (PRV)/ other mechanical protections	
(j)	Pole discrepancy protection of generator transformer breaker (162)	To be provided, if single pole breakers are used.
(k)	Breaker failure protection of generator transformer breaker (50Z)	
(l)	Start-up earth fault protection for LV and HV winding of generator transformer and UATs (64T)	To be provided for GCB scheme only.

3. Unit Auxiliary Transformer(s)

Sl. No.	Protection Function
(a)	Differential protection (87UAT)
(b)	LV back-up earth fault protection (51NUAT)
(c)	LV restricted earth fault (87NUAT)
(d)	Back-up over-current protection (51UAT)
(e)	OTI(49Q) and WTI (49T) trip
(f)	Buchholz (63), PRV/ other mechanical protections

4. Station- Transformer(s)

Sl. No.	Protection Function
(a)	Differential current protection (87)
(b)	Restricted earth fault protection for LV winding (87NLV)
(c)	Restricted earth fault protection for HV winding (87NHV)
(d)	Back-up over-current protection on HV side (51)
(e)	Back-up earth-fault protection (51N)
(f)	Over-fluxing protection (99)
(g)	Buchholz protection (63)
(h)	Winding temperature high (49T)
(i)	Oil temperature high (49Q)
(j)	Pressure relief valve trip (PRV)
(k)	Breaker failure protection (50Z)

SCHEDULE-II

[See sub-regulation (3) of regulation 12]

Design Requirements for Ash Handling System

A. Design Requirements for Ash Handling System of Pulverised Fuel Steam Generators

1. The capacity of ash handling systems, as a percentage of maximum ash generated corresponding to firing of worst coal or lignite at boiler maximum continuous rating, shall not be less than the following:

- 100% standby blowers for intermediate and storage silos;
- 50% standby for air compressors to be used for transporting ash.
- (c) Ash slurry disposal
 - One pump stream as operating standby and one pump stream as maintenance standby for wet slurry system;
 - One standby stream for high concentration slurry system.

SCHEDULE-III

[See sub-regulation (7) of regulation 36]

The minimum Load for Continuous Operation for Various Types of Hydraulic Turbines

Sl. No.	Type of turbine	Minimum load for continuous operation (percent)
(a)	Pelton or Kaplan or Bulb	30
(b)	Deriaz	40
(c)	Francis	50
(d)	Propeller	85

SCHEDULE-IV

[See clause(f) of sub-regulation (12) of regulation 40]

Minimum Protections to be provided for Hydro- electric Generating Units

1. Generator

Sl. No.	Protection functions	Size of generating unit		
		Small (<10 MVA)	Medium (10-100 MVA)	Large (> 100 MVA)
(a)	Differential (87G)	Y	Y	Y
(b)	95 % stator earth fault (64G1)	Y	Y	Y
(c)	100 % stator earth fault (64G2)	N	Y	Y
(d)	Backup impedance (21G)	N	Y	Y
(e)	Voltage controlled over current (51)	Y	N	N
(f)	Negative phase sequence (46G)	Y	Y	Y
(g)	Loss of excitation (40G)	Y	Y	Y
(h)	Reverse power (37/32G)	Y	Y	Y
(i)	Pole slipping (98G)	N	N	Y
(j)	Stator overload (49S)	Y	Y	Y
(k)	Over voltage (59G)	Y	Y	Y
(l)	Under frequency (81G)	Y	Y	Y
(m)	Dead machine (27/50G)	N	N	Y
(n)	Rotor earth fault (64R)	Y	Y	Y

Note: Y- Required; N- Not required.

2. Excitation Transformer

Sl. No.	Protection functions	Size of generating unit		
		Small (< 10 MVA)	Medium (10-100 MVA)	Large (> 100 MVA)
(a)	Restricted earth fault (64)	Y	Y	Y
(b)	Instantaneous and IDMT over current (50/51)	Y	Y	Y
(c)	Winding temperature (49)	Y	Y	Y

Note: Y- Required.

3. Generator Transformer

- Generator transformer differential protection (87T)
- Restricted earth fault protection (64GT)
- IDMT over current protection (51)
- Neutral grounding back-up earth fault protection (51NGT)
- Over head line connection differential protection (87L)
- Overfluxing protection (99GT)
- Monitoring of Insulation of low voltage bushing (59T)
- Buchholtz relay (63)
- Winding temperature protection (49T)
- Oil temperature protection (49)
- Pressure relief valve (PRV)

4. Generator and Generator Transformer

- Overall differential protection (87OA)
- Breaker Failure Protection (50Z)

5. Unit Auxiliary Transformer

- Restricted earth fault protection (64)
- Instantaneous and IDMT over current protection on high voltage winding (50/51)
- Neutral grounding back-up E/F protection (51NGT)
- Winding temperature protection (49T)

6. Station Auxiliary Transformer

- Restricted earth fault protection (64)
- Instantaneous and IDMT over current protection on high voltage winding (50/51)
- Neutral grounding back-up earth fault protection (51NGT)
- Winding temperature protection (49T)

SCHEDULE-V

[See sub-regulation (3) of regulation 48]

Protection Details of Transmission Lines, Transformers, Reactors and Bus Bars**1. Transmission Line Protection**

No.	Protection	765 kV	400 kV	220 kV/230 kV	132 kV/110 kV/ 66 kV
(a)	Main I- Distance protection*	Y	Y	Y	Y (for 132 kV/110 kV) Y/N (for 66 kV)
(b)	Main II- Distance protection* or directional comparison protection or phase segregated line	Y	Y	Y/N 'N' if Directional IDMT over	N

	differential protection			current and earth fault back up protection is provided otherwise 'Y'	
(c)	Directional inverse definite minimum time (IDMT) type earth fault relay	Y	Y	'Y' if both Main-I & Main-II are distance protections otherwise 'N'	N
(d)	Directional IDMT over current and earth fault back up protection	N	N	'Y' if Main-II is not provided otherwise 'N'	Y
(e)	Two stage over voltage protection	Y	Y	Y/N	Y/N
(f)	Auto reclosing#	Y (Single phase and three phase)	Y (Single phase and three phase)	Y (Single phase and three phase)	Y/N (three phase)

***For short line (less than 10 km) or cable or combination of overhead line and cable, line differential protection shall be used with built-in backup distance protection.**

For cable or combination of overhead line and cable, autoreclosing shall not be provided.

Note: (1) Y- Required; N- Not required; Y/N- Optional.

(2) Transmission lines with distance protection shall, in general, have carrier aided or fibre optic based inter-tripping or blocking feature.

(3) Separate cores of current transformer and voltage transformer shall be used for Main-I and Main-II.

2. Transformer Protection

Sl. No.	Protection	765 kV	400 kV	230 kV/220kV/ 132 kV/110 kV	66 kV
(a)	Differential protection	Y	Y	Y	Y
(b)	Over fluxing protection	Y	Y	Y	N
(c)	Restricted earth fault (REF) protection	Y	Y	Y	Y
(d)	Backup directional over current and earth fault protection (HV and LV side) or impedance protection	Y	Y	Y	Y
(e)	Buchholz, WTI and OTI (for 1 MVA and above), MOG with low oil level alarm, OSR for OLTC, PRD, SA on both primary and secondary sides of transformers located outdoors and connected to over head lines	Y	Y	Y	Y
(f)	Tertiary winding protection	Y	Y	Y	N

Note: (1) Y- Required; N- Not required.

(2) WTI- winding temperature indicator; OTI- oil temperature * indicator; OLTC- on load tap changer; PRD- pressure relieve device; OSR- oil surge relay; MOG- magnetic oil gauge; SA- surge arrester.

3. Reactor Protection

Sl. No.	Protection	765 kV	220kV /400 kV
(a)	Differential protection	Y	Y
(b)	REF protection	Y	Y
(c)	Reactor backup protection (impedance type or definite time over current (O/C) and earth fault (E/F) protection)	Y	Y
(d)	Buchholz, WTI, OTI, MOG with low oil level alarm, SA (if required)	Y	Y

Note: (1) Y- Required.

(2) WTI- winding temperature indicator; OTI- oil temperature indicator; MOG- magnetic oil gauge; SA- surge arrester.

4. Bus Bar Protection and Local Breaker Backup Protection (breaker failure protection)

Bus bar protection and local breaker backup protection shall be provided in 220 kV and higher voltage interconnecting sub- stations as well as in all generating station switchyards. Duplication of bus bar protection shall be done for all main buses of 400kV and above voltage class. The bus bar protection scheme shall be centralized or distributed type and have provision for planned future expansion. .

SCHEDULE-VI

(See regulation 49)

PART-A

Technical Details of Classical HVDC Terminals/ Stations

1. **General:** The conventional Thyristor (Gate Turn On device) based HVDC converter technology or Line Commuted Converter technology or Current Source Converter technology shall be used for back to back and long distance bulk power HVDC transmission system. Gate Turn Off devices / other better devices capable of handling similar or higher quantum of power may also be considered.
2. **Design Consideration:** (a) The converter configuration and rating for HVDC installation shall be based on following considerations:
 - (i) The amount of power to be transmitted
 - (ii) The transmission distance
 - (iii) Staging consideration of the project
 - (iv) Location of converter station
 - (v) The amount of power to be transmitted at the different stages of the project
 - (vi) Reliability and availability requirements
 - (vii) Loss evaluation
 - (viii) Size and weight of the Converter transformers for transport
 - (ix) Electrical characteristics of sending and receiving end power system to which HVDC transmission system is connected

Note: The DC power rating shall include nominal, reverse, forward and overload power levels, specific loading cycle and weightage factor to calculate load losses.

- (b) Electric design of HVDC transmission lines shall take into account the following considerations:
 - (i) Corona performance (Corona loss, Radio Interference, Audible Noise, Electric field and ion current in the vicinity of the line)
 - (ii) Air Characteristic
 - (iii) Insulator performance
- (c) The minimum conductor height above Ground level shall be selected mainly on the basis of ensuring human safety, Ground level electric field and ion current density level. The corona loss with I^2R losses

harmonic injection and self-excitation. Sub Synchronous Damping (SSD) Controller shall be provided for converter Stations near Generating stations.

- (A) Load frequency controller (LFC)
- (B) Current margin controller
- (C) Excessive reactive power consumption controller
- (D) AC system stability function, such as power swing damping function.
- (E) Run back / Run up controller with provision to be linked to SPS of System Operator

- (iv) The pole control, converter control, and valve control modules shall also be provided.
- (v) The control shall be designed to give fast stable and proper response to normal control actions as well as during disturbances such as AC & DC faults.

(b) Protection System

- (i) HVDC system protection shall consist of two parts:

- (A) AC side protection:

AC side protection function shall cover the zone for converter transformer, AC filters, shunt capacitors, shunt reactors, and busbars. These protections shall generally follow the same philosophy as in a typical substation i.e. detection of fault by relay and tripping of circuit breaker.

- (B) DC side protection:

DC side protection shall cover the zones consisting of the valve hall, DC switchyard including smoothing reactor and DC filters, DC line, DMR line / electrode line and ground electrode. The protection equipment shall be designed to be fail safe and shall ensure high security to avoid mal-operation/ unwanted shutdown due to protection equipment failures.

- (ii) Following a DC Line fault, the HVDC System shall have the facility to restart, one or more times, the faulted pole at a variable pre-selected DC voltage level(s), not below 80% of the nominal voltage rating. The dc transmission system shall be capable of recovery in a controlled and stable manner without commutation failures during recovery following ac and dc system faults. The post fault power order shall be equal to the pre-fault power order unless AC/ DC systems dictate otherwise

- (iii) Protection system shall have two redundant systems with following protections.

- (A) Converter differential protection;
- (B) DC over current protection;
- (C) DC differential protection;
- (D) AC conductor ground fault protection;
- (E) Commutation failure protection;
- (F) DC filter protection[#];
- (G) DC smoothing reactor protection;
- (H) DC line ground fault protection with restarts[#];
- (I) DC line differential protection[#];
- (J) DC under voltage/ over voltage protection;
- (K) Ground Return mode / Dedicated Metallic Return (DMR) protection[#]
- (L) AC filter protections
- (M) Electrode line monitoring and protection[#]
- (N) Thyristor Failure Monitoring

not applicable for back to back schemes

- (iv) DC online fault locators shall be provided to monitor the entire DC line length and give location of the fault with good accuracy in the range of ± 1000 meters
- (c) Software based controls and protection shall be used to permit flexibility in effecting modifications. Protection and controls shall be duplicated for reliability. The control & protection shall provide fast controllability of the HVDC system. Operation of the HVDC bipole system shall be possible in the following modes:

- (i)Balanced/ unbalanced bipolar operation;
 - (ii)Monopolar operation with pole metallic return:
 - (iii)Monopolar operation with ground return / with Dedicated Metallic Return (DMR) mode;
 - (iv)Reduced voltage operation;
 - (v)Power reversal mode.
- (d) The 'Sequence of events' recorder, transient fault recorder, on-line DC Line fault locator, GPS system, visual display system, operator control protection and monitoring system shall be a part of the HVDC system.
- 14. Telecommunication-** For smooth operation of the HVDC system, communication network with high reliability and availability shall be provided for transmission of control and protection signals between the two or more (in case of multi-terminal DC) HVDC terminals. There shall be main and back up communication link. The main communication link shall be through OPGW and back up communication link shall be either through OPGW or PLCC.
- 15. Valve Hall:** The valve hall shall mainly contain thyristor valves, its associated structure, & cooling and arresters. No oil filled equipment shall be present inside the valve hall. In case the turret of converter transformers (having oil) is protruding inside the valve hall, suitable fire barrier matching with adjacent valve hall wall fire rating shall be provided. The valve halls shall be provided with interference screening. In addition, the control cable and cable termination rooms shall be suitably screened to minimize radio interference. Two nos. scissor lift for erection and maintenance of valve modules shall be provided per station. Proper cable sealing shall be provided for cable entry into valve hall and control room to avoid entry of water and moisture. Necessary measures shall be taken to take care of high frequency noise emission from valves.
- 16. Valve Hall Ventilation:** Suitable ventilation systems and filters with adequate redundancy shall be provided in the valve hall. The valve hall shall be kept at a positive pressure under all conditions.
- 17. Grounding & Safety**
- (a) The design of the grounding system shall be based on relevant IS/ IEEE.
 - (b) In order to prevent adverse effect (overheating due to induced circulating current) of magnetic field of air core reactors, special care shall be taken such that no closed loops are formed by the earthing conductors and in reinforcement bars of the foundation. Air core reactor manufacturer's guidelines shall be followed.
 - (c) The electrical safety clearances for the dc side shall not be less than the clearances applicable for an ac switchyard at the equivalent BIL level.
 - (d) The total electric field excluding space charge at ground level shall be as prescribed in relevant standards.
 - (e) Fencing and electrical & mechanical key interlocking arrangements shall be provided for valve halls, smoothing reactor area, AC and DC filter areas, DC LFL Capacitor Area and for equipment mounted directly on ground without suitable height of steel structure.
- 18. Dedicated Metallic Return (DMR) / Earth Electrode**
- The current return path of a bipolar configuration shall be either via a Dedicated Metallic Return (DMR) conductor or via earth return using earth electrodes at both converter terminals. DMR mode shall be preferred if it is difficult to identify a suitable site for earth electrode station.
- If earth electrodes are to be used the following requirements shall also be considered:
- (a) The earth electrode station shall be connected to the terminal by means of an overhead transmission line. The earth electrode shall be located at a minimum distance of approximately 25 km (radial distance) away from the converter station. It shall be designed to operate continuously at nominal load and overload as per the requirement. The electrodes shall be designed for both types of operation, anodic and cathodic.
 - (b) The thorough soil investigation shall be carried out for shallow and deep resistivity, thermal conductivity and moisture content etc. at the proposed location.
 - (c) The earth electrode station shall have sub-electrodes. The maximum current density at the sub-electrode surface, i.e. the boundary between backfill (coke) and soil shall not exceed 0.5 A/m² in clay soils. The number of sub-electrodes shall be determined considering that 30% of the sub-electrodes are not available. The amp hour rating for earth electrode shall be selected based on the study for duration of earth electrode current and the service life of the earth electrode station.
 - (d) The earth electrode station shall not affect the nearby electrical installation, buried metallic pipelines, oil & gas pipelines, and railway lines etc.

(ii): The above values of creepage distance are applicable for an altitude upto 1000m above sea level. For altitude above 1000m above sea level, necessary altitude correction factor as per relevant IS/IEC shall be considered.

- (c) **DC wall bushing** -DC wall bushings, used for electrical connection between the equipment inside the valve hall and the outdoor DC yard shall be of polymer housing as per relevant standards.
- (d) **DC Reactors** - The DC reactors (if used) shall be of air core type. The reactors shall generally comply with relevant standards and shall also have been subjected to DC tests as per their application.
- (e) **DC Voltage and Current Measuring Devices**- The DC voltage measuring equipment shall be installed at each pole. The DC measuring equipment at pole and neutral bus shall be suitably located based on the control philosophy and different protection zones such that complete pole and neutral equipment are protected.
- (f) **DC Filters**- If required DC harmonic filters shall be provided in DC yard to limit harmonic voltages present on the DC lines (pole lines and electrode lines).

8. Control and Protection

(a) Control

(i) DC converter terminals shall be either manned by operator or controlled by remote Operation of SCADA system. The control system hierarchy shall be as follows:

- (A) Station/ Bipole* Control (*only for bipolar arrangements, functionality offered as part of station control also acceptable);
- (B) Converter /Pole Control;
- (C) MMC control;

(ii) The HVDC converter shall have control features including but not limited to the following:

- (D) Active power control
- (E) Reactive power control;
- (F) AC Voltage control
- (G) DC Voltage control
- (H) Frequency controller (if applicable);
- (I) Power modulation control (if applicable);
- (J) Runback and run-up functions (if applicable);
- (K) Power Oscillation Damping (POD)
- (L) Sub synchronous torsional interaction damping control (if applicable);

(b) Protection

(i) The protection equipment shall be designed to be fail-safe and shall ensure high security to avoid mal-operation/ unwanted shutdown due to protection equipment failures.

(ii) HVDC system protection shall consist of following protection zones:

- (A) AC System Protection zone
- (B) Converter or Interface Transformer Protection Zone
- (C) Secondary Busbar Protection Zone
- (D) Converter Protection Zone
- (E) DC Busbar Protection Zone
- (F) DC line & cable Protection Zone

(iii) Protection system shall have two redundant systems including the following protections.

- (A) AC over- and under-voltage protection
- (B) Over- and under-frequency protection
- (C) AC busbar differential protection;
- (D) Insertion resistor overload protection
- (E) AC overcurrent protection
- (F) Converter overcurrent protection
- (G) Converter overload protection

- (H) Converter module differential protection
- (I) Converter current differential protection
- (J) DC voltage imbalance protection
- (K) DC busbar differential protection
- (L) DC link differential protection
- (M) DC over- and under-voltage protection
- (N) Electrode line monitoring and protection (if applicable)
- (O) DC filter protection (if applicable)
- (P) AC filter protection (if applicable)
- (Q) AC connection Harmonic protection
- (R) Phase current unbalance
- (S) Protection. Block Failure or Repetitive Blocking failure protection
- (T) Converter arm harmonic protection
- (U) DC Line + cable Overcurrent Protection
- (V) DC Line + cable harmonic protection

- (c) Software based controls and protection shall be used to permit flexibility in effecting modifications. Protection and controls shall be duplicated for reliability. Protection shall be provided by numerical relays to suit the requirement of the HVDC system.
- (d) For bipolar schemes the following operation modes shall be possible:
 - (i) Balanced/unbalanced bipolar operation;
 - (ii) Monopolar operation with metallic return;
 - (iii) Monopolar operation with ground return / DMR
- (e) The 'Sequence of events' recorder, transient fault recorder, on-line DC Line fault locator, GPS system, visual display system, operator control protection and monitoring system shall be a part of the HVDC system.

9. Telecommunication- For smooth operation of the HVDC system, communication network with high reliability and availability shall be provided for transmission of control and protection signals between the two or more (in case of multi-terminal DC) HVDC terminals. There shall be main and back up communication link. The main communication link shall be through OPGW and back up communication link shall be either through OPGW or PLCC.

10. Grounding & Safety

- (a) The design of the grounding system shall be based on relevant IS/ IEEE.
- (b) In order to prevent adverse effect (overheating due to induced circulating current) of magnetic field of air core reactors, special care shall be taken such that no closed loops are formed by the earthing conductors and in reinforcement bars of the foundation. Air core reactor manufacturer's guidelines shall be followed.
- (c) The electrical safety clearances for the dc side shall not be less than the clearances applicable for an ac switchyard at the equivalent BIL level.
- (d) The total electric field excluding space charge at ground level shall be as prescribed in relevant standards.
- (e) Fencing and electrical & mechanical key interlocking arrangements shall be provided for valve halls, smoothing reactor area, AC and DC filter areas, DC LFL Capacitor Area and for equipment mounted directly on ground without suitable height of steel structure.

11. Dedicated Metallic Return (DMR) or Earth Electrode –The current return path of a bipolar configuration shall be either via a Dedicated Metallic Return (DMR) conductor or via earth return using earth electrodes at both converter terminals. DMR mode shall be preferred if it is difficult to identify a suitable site for earth electrode station. If earth electrodes are to be used the following requirements shall also be considered:

- (a) The earth electrode station shall be connected to the terminal by means of an overhead transmission line or underground cable. The earth electrode shall be located at a minimum distance of approximately 25 km (radial distance) away from the converter station. It shall be designed to operate continuously at full load as per the requirement. The electrodes shall be designed for both types of operation, anodic and

Annexure D.1

Name of the line	Status as updated in 56/57th PCC meeting	Latest Status		
132 kV Agia - Mendipathar	PLCC works completed. AR operation configuration to commence from March'22. Latest Status to be intimated.			
132 kV EPIP II - Byrnihat D/C				
132 kV EPIP II - Umtru D/C				
132 kV Kahilipara - Umtru D/C				
132 kV Khliehriat – Mustem				
132 kV Mustem - NEHU line				
132 kV Khliehriat (MePTCL) - Khliehriat (PG) Ckt#II				
132 kV Khliehriat- NEIGRIHMS				
132 kV NEHU – Mawlai				
132 kV Mawlai - Umiam Stage I				
132 kV Mawphlang - Nongstoin				
132 kV Mawphlang - Umiam Stg I D/C				
132 kV Mawphlang- Mawlai				
132 kV Mendipathar – Nangalbibra				
132 kV Myntdu Leshka - Khliehriat D/C				
132 kV Nangalbibra – Nongstoin				
132 kV NEHU – NEIGRIHMS				
132 kV NEHU – Umiam				
132 kV Sarusajai - Umtru D/C			By March'22	
132 kV Umiam - Umiam St I				
132 kV Umiam St I - Umiam St II				
132 kV Umiam St I - Umiam St III D/C				
132 kV Umiam St III -Umiam St IV D/C				
132 kV Umiam St III - Umtru D/C				
132 kV Umtru - Umiam St IV D/C				

NERTS

Status of installation of Line Differential Protection is as given below: -

Sl. No.	Line details	Length (in km)	No. of dark fibre pairs required	Status
1	132 kV RC Nagar-Agartala-I	8.384	01	Commissioned
2	132 kV RC Nagar-Agartala-II	8.384	01	
3	132 kV Aizawl-Melriat	6.7	01	By Aug'23
4	132 kV Badarpur-Badarpur	1.023	01	Commissioned
5	132 kV Kumarghat-PK Bari	1.5	01	By Nov'23
6	132 kV Khliehriat-Khliehriat-I	7.801	01	Commissioned
7	132 kV Dimapur-Dimapur I	0.347	01	
8	132 kV Dimapur-Dimapur II	0.95	01	By Aug'23
9	132 kV Imphal-Imphal-I	1.5	01	Commissioned
10	132 kV Imphal-Imphal-II	0.339	01	
11	132 kV B'Chariali - Pavoi - I	12.931	01	
12	132 kV B'Chariali - Pavoi - II	12.931	01	
13	220KV Balipara-Sonabil-I	11	01	
14	220KV Salakati-BTPS-I	4	01	By Aug'23
15	220KV Salakati-BTPS-II	4	01	By Nov'23
16	220kV Mariani (PG)-Mariani (AEGCL)	1.5	01	Commissioned
17	132kV Badarpur - Kolasib	107	01	Commissioned
18	132kV Badarpur - Khliehriat	76.54	01	
19	132kV Badarpur -Silchar - I	19.2	01	Commissioned
20	132kV Badarpur - Silchar- II	19.2	01	
21	132kV Silchar - Hailakandi I	30	01	By Nov'23
22	132kV Silchar - Hailakandi II	30	01	
23	132kV Khliehriat-Khandong - II	40.92	01	Commissioned
24	132kV Khandong-Kopili-II	11	01	
25	132kV Melriat- Zemabawk	10.12	01	
26	132kV Nirjuli - Lekhi	8.301	01	By Jul'23
27	132kV Namsai - Tezu	99.5	01	By Aug'23
28	132kV Roing - Tezu	73	01	
29	132kV Roing - Pasighat	102.85	01	
30	132kV Mokokchung - Mokokchung I	1.44	01	Commissioned
31	132kV Mokokchung - Mokokchung II	1.44	01	
32	132kV Silchar - Srikona I	1.2	01	Commissioned
33	132kV Silchar - Srikona II	1.2	01	
34	132kV Jiribam - Badarpur	67.21	01	By Sep'23
35	132kV Jiribam- Haflong	100.6	01	
36	132kV Aizawl - Kolasib	67	01	By Aug'23
37	132kV Aizawl - Luangmal	0.8	01	
38	132kV Kumarghat - Karimganj	94.94	01	By Nov'23
39	132kV Haflong- Haflong (State)	1.2	01	By Sep'23

Further, for end-to-end communication, SDH has also been utilised for Line Differential Protection as pilot project in following lines: -

1. 132kV Silchar Melriat#1&2
2. 132kV Aizawl Kumarghat

MePTCL

STATUS OF LINE DIFFERENTIAL PROTECTION PROJECT UNDER PSDF					
Sl. No	Feeder Name	Installation		Commissioning	Remarks
		End A	End B		
1	EPIP-I - EPIP II Line I	Completed	Completed	Completed	
2	EPIP-I - EPIP II Line II	Completed	Completed	Completed	
3	EPIP -I - Killing Line I	Completed	Completed	Completed	
4	EPIP -I - Killing Line II	Completed	Completed	Not Completed	Fiber Network Not Available
5	EPIP -I - M/S Maithan Alloy	Completed	Completed	Not Completed	
6	EPIP -I - Shyam Centary	Completed	Completed	Not Completed	
7	EPIP-II - Umtru Line I	Completed	Completed	Completed	
8	EPIP-II - Umtru Line II	Completed	Completed	Completed	
9	EPIP II - New Umtru	Completed	Completed	Completed	
10	EPIP II - Killing Line I	Completed	Completed	Not Completed	Fiber Network Not Available
11	EPIP II - Killing Line II	Completed	Completed	Not Completed	
12	Umtru- New Umtru	Completed	Completed	Completed	
13	LUMSHNONG- M/S MCL	Completed	Completed	Not Completed	Fiber Network Not Available
14	LumSHNONG- M/S ACL	Completed	Completed	Not Completed	
15	Lumshoong - M/S MPL	Completed	Completed	Not Completed	
16	UMIAM - Stage I	Completed	Completed	Not Completed	
17	Umiam - NEHU	Completed	Completed	Completed	
18	UMIAM/STAGE-I - Umiam Stage II	Completed	Completed	Not Completed	Fiber Network Not Available
19	NEHU - NEIGHRIMS	Completed	Completed	Not Completed	Awaiting for Commissioning of fiber under NERFO
20	NEHU - MAWLAI	Completed	Completed	Completed	
21	KHLIEHRIAT (MePTCL)- KHLIEHRIAT(PG) line-II	Completed	Completed	Completed	
22	Stage-III - Stage IV Line I	Completed	Completed	Not Completed	Fiber Network Not Available
23	Stage-III - Stage IV Line II	Completed	Completed	Not Completed	