

भारत सरकार Government of India
विद्युत मंत्रालय Ministry of Power
केन्द्रीय विद्युत प्राधिकरण
Central Electricity Authority

उत्तर पूर्वी क्षेत्रीय विद्युत समिति
North Eastern Regional Power Committee

शिलोंग Shillong

Progress Report

For the month of

July, 2010

CONTENTS		
Sl. No.	Topics	Page No.
1	Brief Highlights of North Eastern Regional Power System	1
2	Salient Features	2
<u>DETAILS OF THE REPORT</u>		
3	Monthly Power Supply Position:	
	(i) Energy generation in the Region	3
	(ii) Requirement Vs Availability in the Region	3
	(iii) Estimation of Peak Demand (MW)	4
	(iv) Estimation of Energy Requirement (MU)	4
4	Station wise Energy Generation (MU) & Peak Generation (MW):	
	(i) State Sector	5, 6
	(ii) Central Sector	7
5	Plant Load Factor (PLF)	8
6	Voltage Profile of Important Sub-Stations	8
7	(i) Inter Regional Energy Exchange	9
	(ii) Major Grid disturbances	9
	(iii) Meetings held by NERPC	9
8	Status of progress of:	
	(i) Generating Units	10
	(ii) Transmission Lines	11, 12
9	Commercial Status:	
	(i) UI Accounting	13
	(ii) Schedule and CS Share Allocation	14, 15
10	NER Grid Status on (i) Regional Peak Demand day	16
	(ii) Regional Minimum Demand day	17
<u>ANNEXURES</u>		
A-1	Major Reservoir Levels	I
A-2	Frequency Analysis and it's Profile	II
A-3	Scheduled Bilateral Exchanges	III
A-4	Energy Exchanges	IV
<u>EXHIBITS</u>		
B-1	Frequency Profile:	
	(i) Duration of frequency in different ranges	I
	(ii) Frequency Variation Index	II
B-2	Voltage Profile:	
	(i) Voltage Profile of Important Sub-Stations	III
B-3	Energy Generation:	
	(i) Energy Generation by Constituents during the month	IV
	(ii) Energy scenario of State's during the month	V
B-4	Reservoir profile :	
	(i) Reservoir statistics for the month	VI

NORTH EASTERN REGIONAL POWER COMMITTEE

Brief highlights of North Eastern Regional Power System for the month of July, 2010

The maximum unrestricted demand during the month of July, 2010 was 1748 MW, which was 1720 MW in the month of June, 2010. The peak demand met in NER during the period under review was 1468 MW, which was 1451 MW last month.

The maximum, minimum & average system frequency were 50.72, 48.71 & 49.81 Hz respectively. The maximum, minimum & average FVI were 3.991, 0.250 & 1.063 respectively. The average FVI was more than its previous month's figure. (refer Annex-II).

Maximum export of power from NER to ER was 440 MW (on 05/07/10 at 14:00 hrs) and that from ER to NER was 176 MW (08/07/10 at 01:00 hrs). Total net energy export during the month was 79.22 MU (to ER).

**SALIENT FEATURES OF
NORTH EASTERN REGIONAL GRID FOR JULY, 2010**

1	New unit/ transmission lines/Transformers commissioned during this month	Nil	
2	Number of total grid disturbance during this month	Nil	
		Jul-10	Jul-09
3	Installed Capacity of the Region (in MW)(grid)	2033.12	2033.12
4	Energy Generation in MU (Gross)::		
	Thermal	343.173	374.498
	Hydel	594.005	421.577
	Diesel / Oil	0.000	0.000
	Total	937.178	796.075
5	Demand in MW ::		
	Registered Peak demand	1748.00	1665.02
	Peak demand met	1468.00	1400.00
	Shortage (% age)	-16.02	-15.92
6	Regional Energy(Gross) in MU ::		
	Energy requirement	899.68	814.41
	Energy availability	818.22	709.34
	Surplus (+) / Deficit (-) (% age)	-9.05	-12.90
7	Inter Regional Energy Exchange in MU ::		
	NER ----> ER	130.598	80.920
	ER ----> NER	51.378	49.890
	Net Export	79.220	31.03
8	Frequency profile ::		
	Average frequency (Hz)	49.81	49.67
	Average Frequency Variation Index	1.063	1.817
9	Load Factor (in %)	62.92	57.26

ENERGY GENERATION IN THE REGION FOR THE MONTH OF Jul-10

All figures in MU

Constituents	Hydro		Coal / Oil fired		Gas Based(OpenCycle)		Gas Based(Com Cycle)		Total(gen)	
	Gross	Net	Gross	Net	Gross	Net	Gross	Net	Gross	Net
	A	B	C	D	E	F	G	H	I	J
State Sector :										
Assam	65.040	64.390	0.000	0.000	67.390	66.716	37.200	36.084	169.630	167.190
Meghalaya	50.490	49.985	0.000	0.000	0.000	0.000	0.000	0.000	50.490	49.985
Mizoram	0.000	0.000	0.000	0.000	0.000	0.000	0.000	0.000	0.000	0.000
Tripura	4.680	4.633	0.000	0.000	51.093	50.582	0.000	0.000	55.773	55.215
Nagaland	8.900	8.811	0.000	0.000	0.000	0.000	0.000	0.000	8.900	8.811
Total (State Sector)									284.793	281.201
Central Sector :										
NEEPCO :										
Khd+Kop+Kop-II	144.920	143.471	0.000	0.000	0.000	0.000	0.000	0.000	144.920	143.471
K'guri	0	0	0.000	0.000	0	0	134.620	130.581	134.620	130.581
RCNagar	0	0	0	0	52.870	52.341	0	0	52.870	52.341
Doyang	53.360	52.826	0	0	0	0	0	0	53.360	52.826
Ranganadi	200.160	198.158	0	0	0	0	0	0	200.160	198.158
NHPC :										
Loktak	63.850	63.212	0.000	0.000	0.000	0.000	0.000	0.000	63.850	63.212
Total (Central Sector)									649.780	640.590
Total NER	591.400	585.486	0.000	0.000	171.353	169.639	171.820	166.665	934.573	921.791

REQUIREMENT Vs AVAILABILITY IN THE REGION

STATES	ENERGY requirement (MU) at 50 Hz				POWER requirement (MW) at 50 Hz			
	<i>Availability & L/S at prevailing freq.</i>				<i>Availability & L/S at prevailing freq.</i>			
	Requirt.	Availy.	Shortfall	%Shortfall	Requirt.	Availy.**	Shortfall	%Shortfall
Ar.Pr.	43.85	36.96	6.89	15.71%	95	73	22	23.12%
Assam	504.62	472.75	31.87	6.32%	900	855	45	4.99%
Manipur	49.58	45.70	3.88	7.83%	106	100	6	6.01%
M'laya	129.93	114.13	15.80	12.16%	280	204	76	27.13%
Mizoram	30.25	26.47	3.78	12.50%	70	61	9	12.83%
Nagaland	52.66	46.52	6.14	11.65%	118	102	16	13.54%
Tripura	88.79	75.69	13.10	14.76%	185	146	39	21.27%
REGION	899.68	818.22	81.46	9.05%	1748	1468	280	16.03%

ESTIMATION OF PEAK DEMAND (in MW)

Constituents	Peak Demand Met	Date	Freq. (Hz)	Freq. Corr.**	L/S	Estimated Peak demand at 50 Hz
Arunachal Pradesh	73.00	24/07/2010	50.02	-0.04	22	94.96
Assam	855.00	05/07/2010	50.08	-2.05	47	899.95
Manipur	100.00	27/07/2010	49.87	0.39	6	106.39
Meghalaya	204.00	31/07/2010	50.01	-0.06	76	279.94
Mizoram	61.00	14/07/2010	50.01	-0.02	9	69.98
Nagaland	102.00	14/07/2010	50.01	-0.03	16	117.97
Tripura	146.00	02/07/2010	49.67	1.45	38	185.45
REGION	1468.00	19/07/2010	49.70	13.21	267	1748.21

** Freq.Correction = Demand met x 0.03 x (50 - Av. Freq.)

ESTIMATION OF ENERGY REQUIREMENT (in MU)

Average Frequency **49.81** Hz

Constituents	Generation	Energy drawal from grid			Over(+) / Under(-) Drawal	Energy Availability*	Freq. Corr.**	L / S	Actual Requirement
		Entitlement frm ISGS of NER	Entitlement frm ISGS of ER	Drawal					
Ar.Pr.	0.000	60.475	2.753	36.964	-26.264	36.964	0.211	6.68	43.854
Assam	167.190	295.082	89.936	305.556	-79.462	472.745	2.695	29.18	504.620
Manipur	0.000	63.443	0.000	45.702	-17.741	45.702	0.261	3.62	49.582
M'laya	49.985	79.570	17.375	64.148	-32.797	114.133	0.651	15.15	129.934
Mizoram	0.000	33.639	0.000	26.469	-7.171	26.469	0.151	3.63	30.250
Nagaland	8.811	42.475	11.290	37.710	-16.055	46.521	0.265	5.87	52.656
Tripura	55.215	52.351	0.000	20.471	-31.880	75.686	0.431	12.67	88.788
REGION	281.201	627.035	121.354	537.019	-211.371	818.220	4.664	76.80	899.684

*Energy availability means energy consumed by constituents

** Freq.Correction = Demand met x 0.03 x (50 - Av.Freq.)

ENERGY GENERATED (MU) AND PEAK GENERATION (MW) FROM GENERATING STATIONS/UNITS:

Sl. No.	Power Stations / Units	Installed Capacity(MW)	Peak Generation(MW)	Energy Generation (MU)	
				Jul-10	Jul-09
STATE SECTOR : HYDRO					
ASSAM :: HYDRO					
1	KARBI HEP U - 1	50.00	50.00	31.960	19.320
2	KARBI HEP U - 2	50.00	50.00	33.080	26.350
TOTAL		100.00		65.04	45.67
MEGHALAYA :: HYDRO					
1	STAGE - 1	36.00	27.10	6.080	10.830
2	STAGE - 2	18.00	29.10	14.460	5.120
3	STAGE - 3	60.00	30.00	27.300	18.340
4	STAGE - 4	60.00	60.70	2.020	23.260
5	UMTRU	11.20	5.70	0.630	4.820
TOTAL		185.20		50.490	62.370
NAGALAND :: HYDRO					
6	LIKIMRO - 1				
7	LIKIMRO - 2	24.00	20.00	11.510	8.750
8	LIKIMRO - 3				
TOTAL		24.00		11.510	8.750
TRIPURA :: HYDRO					
9	GUMTI - 1	5.00	Gumti Stn. Peak =8 MW	0.890	0.000
10	GUMTI - 2	5.00		2.260	2.876
11	GUMTI - 3	5.00		1.530	2.811
TOTAL		15.00		4.680	5.687
TOTAL STATE (HYDRO) :		324.20		131.720	122.477

ENERGY GENERATED (MU) AND PEAK GENERATION (MW) FROM GENERATING STATIONS/UNITS:

Sl. No.	Power Stations / Units	Installed Capacity(MW)	Peak Generation(MW)	Energy Generation (MU)	
				Jul-10	Jul-09
STATE SECTOR : THERMAL/GAS					
MIZORAM :: Thermal					
1	Bairabi	22.92	0.00	0.000	0.000
TRIPURA :: THERMAL					
1	BARAMURA - 1	5.00	Baramura Stn. Peak = 21 MW	0.000	0.000
2	BARAMURA - 2	5.00		0.000	0.000
3	BARAMURA - 3	6.50		0.000	0.000
4	BARAMURA - 4	21.00		15.030	15.466
5	ROKHIA - 1	8.00	Rokhia Stn. Peak = 56 MW	0.000	0.000
6	ROKHIA - 2	8.00		0.000	0.000
7	ROKHIA - 3	8.00		3.560	4.337
8	ROKHIA - 4	8.00		4.063	1.708
9	ROKHIA - 5	8.00		0.000	0.000
10	ROKHIA - 6	8.00		0.000	0.000
11	ROKHIA - 7	21.00		14.210	14.388
12	ROKHIA - 8	21.00		14.230	14.959
	TOTAL	127.50		51.093	50.858
ASSAM :: THERMAL					
1	LTPS - 1	15.00	LTPS Stn. Peak = 113 MW	6.560	8.700
2	LTPS - 2	15.00		9.370	8.730
3	LTPS - 3	15.00		9.770	9.550
4	LTPS - 4	15.00		7.430	9.080
5	LTPS - 5	20.00		10.150	2.890
6	LTPS - 6	20.00		11.640	15.320
7	LTPS - 7	20.00		7.270	6.760
8	NTPS - 1	20.00	NTPS Stn. Peak = 70 MW	5.420	13.220
9	NTPS - 2	21.00		11.170	11.270
10	NTPS - 3	21.00		8.880	9.140
11	NTPS - 4	11.00		5.240	4.550
12	NTPS - 5	22.00		0.000	7.110
13	NTPS - 6	22.00		6.490	7.770
14	DLF	24.50			5.200
	TOTAL	261.50		104.590	121.270
TOTAL STATE THERMAL/GAS :		411.92		155.683	172.128
TOTAL SC GEN(HY+TH/GAS)		736.12		287.403	294.605

ENERGY GENERATED (MU) AND PEAK GENERATION (MW) FROM GENERATING STATIONS/UNITS:

Sl. No.	Power Stations / Units	Installed Capacity(MW)	Peak Generation(MW)	Energy Generation (MU)	
				Jul-10	Jul-09
CENTRAL SECTOR : HYDRO					
1	KHANDONG - 1	25.00	25.00	12.230	12.940
2	KHANDONG - 2	25.00	25.00	15.020	11.460
3	KOPILI Stg - II	25.00	25.00	15.120	12.740
4	KOPILI - 1	50.00	50.00	32.350	19.750
5	KOPILI - 2	50.00	0.00	0.000	24.410
6	KOPILI - 3	50.00	50.00	34.630	0.000
7	KOPILI - 4	50.00	50.00	35.570	23.250
8	DOYANG -1	25.00	Doyang Stn. Peak = 72.6 MW	18.180	8.170
9	DOYANG -2	25.00		17.190	5.960
10	DOYANG -3	25.00		17.990	7.300
11	LOKTAK - 1	35.00	Loktak Stn. Peak = 99 MW	15.970	1.730
12	LOKTAK - 2	35.00		23.730	6.280
13	LOKTAK - 3	35.00		24.150	0.350
14	RANGANADI - 1	135.00	Ranganadi Stn. Peak =406 MW	58.610	56.380
15	RANGANADI - 2	135.00		70.220	54.280
16	RANGANADI - 3	135.00		71.330	54.100
TOTAL HYDRO :		860.00		462.290	299.100
CENTRAL SECTOR : THERMAL/GAS					
1	KATHALGURI - 1	33.50	Kathalguri Stn. Peak = 212 MW	19.690	21.180
2	KATHALGURI - 2	33.50		19.530	20.230
3	KATHALGURI - 3	33.50		20.300	21.720
4	KATHALGURI - 4	33.50		19.760	19.350
5	KATHALGURI - 5	33.50		18.170	0.000
6	KATHALGURI - 6	33.50		0.000	20.410
7	KATHALGURI - 7	30.00		15.020	17.530
8	KATHALGURI - 8	30.00		16.130	17.960
9	KATHALGURI - 9	30.00		6.020	7.540
10	R.C.NAGAR - 1	21.00	RC Nagar Stn. Peak = 80 MW	10.810	14.280
11	R.C.NAGAR - 2	21.00		13.950	14.330
12	R.C.NAGAR - 3	21.00		13.800	13.950
13	R.C.NAGAR - 4	21.00		14.310	13.890
TOTAL THERMAL/GAS :		375.00		187.490	202.370
TOTAL CS (HY + TH/GAS) :		1235.000		649.780	501.470
TOTAL NER GEN(HY+TH/GAS) :		1971.120		937.183	796.075

Plant Load Factor (PLF) and Voltage Profile :

Jul-10

PLANT LOAD FACTOR OF THE THERMAL/ GAS STATIONS IN NER

Sl. No.	Power Station	State/ Constituent	Installed Capacity (MW)	Generation (in MU)	Stationwise PLF (%)
1	LTPS*	AEGCL	120.00	62.190	69.66
2	NTPS*	AEGCL	117.00	37.200	42.74
3	Baramura	Tripura	37.50	15.030	53.87
4	Rokhia	Tripura	90.00	36.063	53.86
5	AGBPP	NEEPCO	291.00	134.620	62.18
6	AGTPP	NEEPCO	84.00	52.870	84.60
7	Bairabi	Mizoram	22.92	0.000	0.00

*LTPS-- Lakwa Thermal Power Station, NTPS-- Namrup Thermal Power Station

VOLTAGE PROFILE :

A. MAXIMUM AND MINIMUM VOLTAGE (kV) OF IMPORTANT SUB - STATIONS :

Sl. No.	NAME OF S/S	MAXIMUM (kV)	MINIMUM (kV)
1	BALIPARA 400 kV	424	395
2	MISA 400 kV	426	395
3	MISA 220 kV	229	218
4	SALAKATI 220 kV	232	212
5	HAFLONG 132 kV	138	130
6	AIZAWL 132kV	137	121
7	KUMARGHAT 132kV	143	126

Voltage Range in kV as percentage of time for the block

SUB-STATION	kV < 360	360<kV<380	380<kV<420	kV>420
MISA	0.00	0.00	95.81	4.19
BALIPARA	0.00	4.36	94.96	0.68

1 **INTER - REGIONAL EXCHANGE :**

All Fig in MU

NER to ER	130.598
ER to NER	51.378
NET EXPORT	79.220

2 **Major Grid Disturbances during this month**

NIL

3 **MEETING HELD BY NERPC DURING THIS MONTH**

1. 52nd OCC Meeting was held on 16.07.10 at Hotel Japfu, Kohima, Nagaland.

PROGRESS OF GENERATION PROJECTS IN NER

Name of the Generation Scheme	No. of Units	Capacity (MW)	Commissioning Schedule	REMARKS
[A] NEEPCO				
1. Monarchak TGBPP		104	2013	Activities in progress
2. Tuirial HEP Mizoram	2	2 X 30	WORKS HELD-UP	Being reviewed by PIB
3. Kameng HEP A. Pradesh	4	4X150	2012-13	Activities in progress
4. Tuival H.E. Proj. Mizoram	3	3X70	2015	Status not available
5. Tipaimukh HEP		1500	2015	Activities in progress
6. Mawphu HEP	2	90	2014	UNDER CCEA
7. Pare HEP, Ar. Pradesh		110	2015	UNDER CCEA
[B] NHPC				
a). Loktak Downstream HEP	2	66	2014	Activities in progress
b) Subansiri Lower HEP		2000	2013	Activities in progress
c) Siang Middle HEP		2000	2016	Activities in progress
d) Subansiri Upper HEP		2000	DPR Under prep	
e) Subansiri Middle HEP		1000	DPR Under prep	
f) Dibang Multipurpose Project		3000	Under TEC	
[C] NTPC				
a). Bongaigaon TPS	3	3X250	2012	Activities in progress
[D] JV PROJECT				
a). Palatana CCPP	2	2X323.3	2012	Activities in progress
[E] ASSAM				
(a) Lakwa WHRP		37.2	2012	Activities in progress
(b) Namrup CCPP	2	2X40	2012	
[F] MIZORAM				
(a) Tuivai Hydel Project	2	51	2012	Activities in progress
(b) Bairabi Dam Project	2	2 X 40	2012	Activities in progress
[G] MeSEB				
(a) Myntdu - Leishka HEP	2	3x42	2011	Activities in progress
(b) New Umtru HEP	2	2X20	2013	Activities in progress
[H] Tripura				
(a) Baramura GT # U-V	1	25	2010	Activities in progress

PROGRESS OF TRANSMISSION LINES IN NE REGION									
	Name of the line	Length	Comm'nng Sch		Total no.	Stubs com -	Tower	Stringing	Remarks
		(ckt kms)	Ann.pl	Ant/revd	of locs .	pleted(nos)	Erected	complt-ckm	
A : Lines under ASEB.									
1	132 kV Nazira - Lakwa 2nd Ckt	21						Completed	Work in progress
2	132 kV, S/C Rangia - Sipajhar - Rowta- Depota	147							Work in progress
3	132 kV, S/C Sarusajai - Kahilipara	8							Work in progress
4	LILO of 132 kV Mariani - Dimapur S/C at Bokajan	6					completed		Rly Clearance awaited
5	132 kV Nazira- Garmur (Mariani) S/C	63							Tender is in progress
6	220 kV Kathalguri - Tinsukia 2nd Ckt	50	2006-07						Work in progress
D : Lines under Meghalaya :									
1	Myntdu Leshka-Khlieriat 132 KV D/C			2011					Work in progress
2	220 kV Misa-Byrinahat D/C			2010					Work in progress
3	132 kV Agia - Nangalbibra								Work in progress
E : Lines under Mizoram :									
1	132 kV Khawzawl-E Lungdar S/C	48			100	100	76	0	Work in progress
2	132 kV Khawzawl-Ngopa S/C	57			117	117	117	57	Work in progress
3	132 kV Kolasib-Tuirial S/C	41			114	114	114	41(Conductor)	Work in progress
4	Kolasib-Sairul B D/C	25							Work in progress
5	132 kV Kolasib-Melriat S/C	90			369	Nil	Nil	Nil	Work in progress
6	132 kV Bairabi-Bawktlang S/C	30			93	91	85	14	Work in progress
7	132 kV Khawzawl-Champhai S/C	30			90	Nil	Nil	Nil	Work in progress
G : CTU Lines:									
1	+/- 800 kV HVDC Bipol Bis'nath Chariali-Agra	1971	08/2013	08/2013	2293	1016	210		All tower packages awarded
2	400 kV Balipara - Biswanath Chariali D/C	130	08/2013	08/2013	167	98	40		
3	LILO of 400 kV R'nadi-Balipara D/C at Bis Chariali	54	08/2013	08/2013	68	5			
4	400 kV Kameng - Balipara D/C	110	02/2013	02/2013	142	9			
5	400 kV Balipara - Bongaigaon D/C	596	02/2013	03/2012	838	445	137		
6	400 kV Lower Subansiri - Biswanath Chariali line-I	334	02/2013	03/2012	432	198	85		
7	400 kV Lower Subansiri - Biswanath Chariali line-II	340	02/2013	03/2012	442	192	55		
8	LILO of 132 kV Dimapur-Kohima at Dimapur (PG)	2	09/2009	03/2011	3				ROW problem
9	132 kV Kopili-Khandong	12	09/2009	12/2010	43	37	37	10	ROW problem
10	132 kV D/C Biswanath Chariyali- B. Chariyali (AEGCL)	32	08/2013	08/2013	55				Engg.&survey under prog.
11	400 kV D/C Bongaigaon TPS-Bongaigaon								
12	400 kV Palatana - Silchar	248							
13	400 kV Silchar - Bongaigaon	405							

Name of the line	Length	Comm'n'g Sch		Total no. of locs.	Stubs com - pleted(nos.)	Tower Erected	Stringing complt-ckm	Remarks
	(ckt kms)	Ann.pl	Ant/revd					
H : Lines under Arunachal Pradesh								
i) Transmission Lines Plan works completed & on going								
1. 132 kV Nirjuli - Itanagar S/C (Under NLCPR)		2007-12				Completed	in progress	Work is in progress
2. 132 kV Along - Pasighat (Under NLCPR)		2007-12						Work is in progress
3. 132 kV Ranganadi - Itanagar S/C		2007-12						Work is in progress
ii) Proposed for XIth Five Years Plan (State)								
1. 132 kV Khupi - Seppa		2007-12						Work is in progress
2. 132 kV Line LILO at Bhalukpong		2007-12						Work is in progress
3. 132 kV Nirjuli - Banderdewa		2007-12						Work is in progress
4. 132 kV Along - Yingkiong		2007-12						Work is in progress
5. 132 kV Naharlagun - Seppa		2007-12						Work is in progress
6. 132 kV Roing - Anini		2007-12						Work is in progress
7. 132 kV Along - Reying		2007-12						Work is in progress
8. 132 kV Tezu - Roing		2007-12						Work is in progress
9. 132 kV Namsai - Tezu		2007-12						Work is in progress
10. 132 kV Ziro - Sangram		2007-12						Work is in progress
iii) Proposed for XIth Five Years Plan (NLCPR)								
1. 132 kV Pasighat - Roing		2007-12						Work is in progress
2. 132 kV Likabali - Gerukamukh		2007-12						Work is in progress
3. 132 kV Pasighat - Niglok		2007-12						Work is in progress
4. 132 kV Deomali - Khonsa		2007-12						Work is in progress
5. 132 kV Khupi - Banderdawa		2007-12						Work is in progress
6. 132 kV Banderdawa - Tawang		2007-12						Work is in progress
7. 132 kV Khonsa - Changlang		2007-12						Work is in progress
8. 132 kV Changlang - Jairampur		2007-12						Work is in progress
9. 132 kV Jairampur - Miao		2007-12						Work is in progress
10. 132 kV Itanagar - Seijusa		2007-12						Work is in progress
11. 132 kV Seijusa - Balipara		2007-12						Work is in progress
iv) Proposed for XIth Five Years Plan (NEC)								
1. 132 kV Niglok - Likabali		2007-12						Work is in progress
2. 132 kV Itanagar - Gohpur		2007-12						Work is in progress

UI Receivable/ Payable for the month of**Jul-10**

Organisation	Actual (MU)	Schedule (MU)	UI Energy (MU)	UI Receivable (Rs. in Lakhs)	UI Payable (Rs. in Lakhs)
Arunachal Pradesh	36.964	43.986	-7.023	258.04	23.99
ASEB	305.556	324.721	-19.166	564.81	56.41
Manipur	45.702	64.871	-19.169	623.65	0.34
MeSEB	64.148	67.766	-3.618	219.69	13.27
Mizoram	26.469	34.283	-7.814	258.03	0.83
Nagaland	37.710	36.602	1.107	27.83	58.78
Tripura	20.471	22.813	-2.342	98.72	16.00

Entitlement, Schedule, Drawal and UI Charges**Jul-10**

	Entitlement from CGSs (MU)	Drawal Schedule from CGSs (MU)	Net Schedule from Grid (MU)	Actual Drawal from Grid (MU)	Over Drawal (+) / Under Drawal (-) (MU)	UI Payable (-) / Receivable (+) (Rs. In Cr)
Arunachal Pradesh	60.475	60.531	43.986	36.964	-7.023	2.341
ASEB	295.082	294.925	324.721	305.556	-19.166	5.084
Manipur	63.443	63.483	64.871	45.702	-19.169	6.233
MeSEB	79.570	79.595	67.766	64.148	-3.618	2.064
Mizoram	33.639	33.645	34.283	26.469	-7.814	2.572
Nagaland	42.475	42.454	36.602	37.710	1.107	-0.309
Tripura	52.351	52.549	22.813	20.471	-2.342	0.827

(Source : UI A/c, NERPC)

Schedule for ISGS's Generation and State's Drawl for the month of

Jul-10

States	Schedule From ISGS(MWH)	Bilateral Schedule from Outside NER (MWH)	Total Schedule (MWH)	Ex.PP. Drawal (MWH)	Tr. Energy (MWH)
Arunachal Pradesh	60457.09	2841.38	63298.46	38260.11	63298.46
ASEB	294922.09	92824.025000	387746.11	316271.82	387746.11
Manipur	63418.97		63418.97	47304.75	63418.97
MeSEB	79535.80	17933.675000	97469.48	66397.84	97469.48
Mizoram	33622.48		33622.48	27397.12	33622.48
Nagaland	42457.38	11652.18	54109.56	39032.28	54109.56
Tripura	52320.98		52320.98	21189.05	52320.98
Total	626734.78	125251.25	751986.03	555852.99	751986.03

ISGS	Schedule (MWH)	Injection (MWH)
LOKTAK	60774.09	62947.81
KHANDONG	27282.35	27473.46
KOPII-I	92975.63	100540.26
KOPII-II	14850.30	14894.04
DHEP	51042.59	52227.58
RHEP	197163.24	198516.95
AGTPP	51530.25	51826.51
AGBPP	131116.34	130726.69
Total	626734.78	639153.28

Source : Provisional REA for the month: Jul-10

Cumulative wt. Average Share Allocation (%) (Up to this month) in CS Stations

States	KOPILI	KOPILI-II	KHANDONG	RHEP	DHEP	AGBPP	AGTPP	Loktak HEP
	(200 MW)	(25 MW)	(50 MW)	(405 MW)	(75 MW)	(291 MW)	(84 MW)	(90 MW)
Arunachal Pradesh	5.193	6.193	4.192	18.462	6.882	5.693	6.180	4.942
Assam	53.455	46.615	56.277	43.328	43.742	56.465	45.178	29.415
Manipur	7.385	7.225	6.565	8.373	7.893	8.125	8.143	30.115
Meghalaya	17.150	18.650	16.650	11.250	11.230	11.550	11.340	12.140
Mizoram	4.619	6.278	3.940	5.710	5.240	5.429	6.190	5.068
Nagaland	6.155	5.656	6.653	5.335	17.935	5.805	5.607	6.427
Tripura	6.043	9.383	5.723	7.542	7.078	6.933	17.362	11.893
Total	100.00	100.00	100.00	100.00	100.00	100.00	100.00	100.00

Details of Fixed and Energy Charges of CS Stations for FY 2009-10

Projects	Installed Capacity (MW)	Design Energy (GWh)	Annual Fixed Charge (Rs. Crore)	Reference
KOPILI HEP	200	1186.14*	57.6738 *	*As per CERC order dated 19.02.08 in petition No 76/2007.
KOPILI -II	25	86.3*	12.9511 **	* Provisional, ** As per CERC order dated 01.01.08 in pet. No 70/2006
KHANDONG HEP	50	277.61*	19.6328 *	*As per CERC order dated 14.01.08 in petition No 26/2007.
RHEP	405	1509.69	203.4081	*As per CERC order dated 30.04.08 in petition No 89/2007.
DHEP	75	227.24	58.5 *	*As per CERC order dated 03.10.07 in petition No 88/2007.
AGBPP	291	NA	233.59 *	*As per CERC order dated 22.02.08 in Pet.No150/2005, ^ Base Rate of energy Charge as per CERC Order
AGTPP	84	NA	52.71 *	*As per CERC order dated 20.02.08 in Pet.No 135/2005,^Base Engy. charge as per CERC order
LOKTAK HEP	105	448.00	50.0353 *	*As per CERC order dated 05.09.07 in Pet.No 171/2004

HOURLY DATA ON PEAK DEMAND MET DAY

DATE:- 19.07.2010

All figures in MW

HRS.	Total ISGS Injection (MW)	STATE SECTOR														ER					Total Drawal by States
		ASEB			MeSEB			Tripura			Manipur	Mizoram	Nagaland	ArPr	Total N.E.R GEN		Total Demand Met	Gross Demand met	Actual Loss		
		GEN	Drawal	Demand Met	GEN	Demand Met	Drawal	GEN	Demand Met	Drawal	DM	DM	DM	DM							
1	742.32	205	374.37	579.7	53	123.8	70.90	71	112.8	42.30	34.92	24.78	41.08	41.41	-90.10	1071.08	958.51	981.02	22.5	719.81	
2	727.89	205	359.83	565.1	63	148.6	85.76	71	110.3	39.74	27.00	23.59	39.63	39.72	-84.42	1066.63	954.01	982.26	28.2	699.64	
3	728.59	169	327.05	496.1	87	182.9	96.00	70	106.5	36.15	16.71	23.28	39.02	40.77	-118.60	1054.89	905.28	936.33	31.0	697.54	
4	729.89	170	308.76	478.5	73	176.0	102.60	70	101.5	31.32	14.91	22.41	37.07	36.81	-154.50	1043.25	867.23	888.79	21.6	708.34	
5	734.80	170	284.58	454.3	73	182.2	108.82	70	91.9	21.56	21.96	25.21	43.53	39.19	-162.66	1048.27	858.32	885.65	27.3	707.48	
6	731.33	170	258.42	428.5	74	189.4	115.86	70	80.7	10.66	39.33	33.78	60.29	44.60	-145.06	1045.06	876.67	900.05	23.4	707.95	
7	844.84	170	267.03	437.2	74	192.9	119.14	70	80.5	10.43	51.67	44.86	56.96	46.33	-229.32	1158.76	910.33	929.48	19.1	825.69	
8	840.70	170	275.33	445.5	81	197.5	116.81	70	87.0	16.63	64.64	43.80	51.54	39.60	-201.64	1161.86	929.52	960.26	30.7	809.96	
9	890.78	170	323.53	493.7	81	192.7	112.11	71	89.5	18.85	54.49	34.91	41.81	35.25	-249.41	1212.13	942.31	962.76	20.4	870.33	
10	886.27	170	329.03	499.2	81	173.9	93.25	70	91.7	21.37	54.67	32.83	44.51	35.71	-251.34	1207.35	932.45	956.06	23.6	862.67	
11	885.48	170	326.37	496.5	80	180.2	99.91	70	89.1	18.74	58.68	32.66	33.65	36.47	-252.81	1206.24	927.24	953.46	26.2	859.26	
12	1003.85	170	354.63	524.8	84	157.2	73.13	70	84.2	14.05	47.89	34.59	39.54	39.46	-348.50	1328.18	927.63	979.73	52.1	951.76	
13	1030.45	171	379.19	550.0	80	146.8	66.35	70	86.1	15.69	52.38	35.54	38.08	42.79	-369.65	1352.23	951.80	982.62	30.8	999.63	
14	1025.26	171	360.17	531.0	80	157.7	77.37	69	92.0	23.04	68.40	36.17	45.86	41.00	-343.74	1345.39	972.14	1001.69	29.6	995.71	
15	1027.05	170	366.29	536.0	74	135.1	61.49	70	97.4	27.07	72.01	40.88	46.46	38.43	-346.22	1340.75	966.34	994.57	28.2	998.82	
16	1022.24	170	361.81	531.9	99	166.6	67.86	68	92.7	24.19	75.91	46.96	52.35	48.72	-320.62	1359.61	1015.17	1039.03	23.9	998.38	
17	1015.39	170	400.48	570.6	99	165.7	66.60	70	94.9	25.27	66.06	49.10	55.57	62.47	-260.30	1354.18	1064.34	1093.96	29.6	985.77	
18	1043.99	171	474.59	645.5	96	154.5	58.57	71	115.6	44.79	68.14	53.96	67.06	66.67	-184.58	1381.52	1171.31	1197.02	25.7	1018.28	
19	1026.00	171	588.42	759.3	101	172.7	71.95	68	128.2	59.69	90.06	56.49	74.86	77.01	32.62	1366.03	1358.53	1398.74	40.2	985.79	
20	1027.59	221	534.31	755.0	123	192.6	69.60	70	126.0	56.03	88.86	54.85	72.50	72.40	-37.71	1441.24	1362.20	1403.62	41.4	986.18	
21	1025.48	221	569.83	790.9	123	197.3	74.44	74	125.9	51.69	91.18	51.39	64.81	69.25	-14.66	1443.56	1390.67	1428.98	38.3	987.16	
22	1020.23	222	541.47	763.6	118	184.7	67.22	76	124.5	48.81	86.06	42.88	62.13	69.49	-65.18	1435.54	1333.36	1370.44	37.1	983.15	
23	1016.29	223	499.21	722.1	111	185.0	74.04	74	123.7	50.11	68.41	34.82	51.65	55.67	-153.29	1423.71	1241.33	1270.46	29.1	987.16	
24	986.77	222	411.61	633.8	94	183.3	89.76	74	121.5	47.67	50.35	27.99	41.31	47.90	-256.99	1376.36	1106.18	1119.41	13.2	973.54	
Max	1043.99	223	588.42	790.88	123	197.5	119.14	76	128.2	59.69	91.18	56.49	74.86	77.01	32.62	1443.56	1390.67	1428.98	52.1	1018.28	
Min	727.89	169	258.42	428.55	53	123.8	58.57	68	80.5	10.43	14.91	22.41	33.65	35.25	-369.65	1043.25	858.32	885.65	13.2	697.54	

HOURLY DATA ON MINIMUM DEMAND MET DAY

DATE: 01.07.2010

All figures in MW

HRS.	Total ISGS Injection (MW)	STATE SECTOR													ER	Total N.E.R GEN	Total Demand Met	Gross Demand met = Sum of demand met of all the states+loss	Actual Loss	Total Drawal by States
		ASEB			MeSEB			Tripura			Manipur	Mizoram	Nagaland	ArPr						
		GEN	Demand Met	Drawal	GEN	Demand Met	Drawal	GEN	drawal	Demand Met	DM	DM	DM	DM						
1	915.99	242	677.6	435.24	48	160.6	112.55	77	25.48	102.52	39.85	18.85	39.65	47.64	-171.70	1283.5	1086.7	1111.83	25.1	890.91
2	912.02	242	674.0	431.62	48	152.0	104.09	77	22.54	99.77	35.27	18.19	36.79	47.17	-191.71	1279.5	1063.2	1087.88	24.7	887.32
3	911.17	243	657.7	414.94	48	156.1	107.98	77	20.47	97.56	28.98	17.57	39.79	38.58	-215.92	1279.1	1036.2	1063.20	27.0	884.17
4	887.63	243	628.2	385.13	48	173.5	125.65	77	16.61	93.67	28.80	17.96	39.75	41.42	-201.66	1255.6	1023.3	1054.02	30.7	856.92
5	912.29	243	583.2	340.45	30	153.1	123.46	77	9.47	86.68	34.94	21.25	47.36	45.65	-263.04	1261.9	972.2	998.89	26.7	885.56
6	903.49	242	558.1	315.73	30	153.1	123.46	77	8.08	85.23	62.22	29.59	60.02	54.45	-228.89	1252.6	1002.7	1026.37	23.7	879.79
7	852.42	243	559.0	315.93	43	187.0	144.00	67	9.81	76.94	71.01	38.79	65.27	56.96	-113.83	1205.7	1055.0	1091.90	36.9	815.55
8	842.89	243	586.5	343.43	43	189.2	146.31	67	11.83	79.17	69.71	38.64	57.95	55.98	-83.73	1196.2	1077.2	1112.56	35.4	807.52
9	844.40	243	614.8	371.71	43	166.5	123.74	72	11.52	83.44	39.87	30.95	40.71	45.31	-159.75	1202.2	1021.6	1042.51	20.9	823.48
10	835.36	243	639.8	397.05	56	166.1	109.70	77	13.57	90.34	50.22	27.73	35.79	47.56	-128.50	1211.2	1057.5	1082.79	25.3	810.08
11	737.86	242	646.9	404.58	56	157.0	100.62	77	20.28	96.84	57.93	27.49	38.95	50.34	-17.75	1113.1	1075.5	1095.44	20.0	717.88
12	747.85	243	578.7	336.00	70	165.6	95.85	76	12.52	88.81	61.15	27.13	30.78	49.92	-110.63	1136.6	1002.1	1026.06	23.9	723.92
13	747.53	243	606.9	364.16	65	118.8	53.60	77	15.71	92.44	72.06	27.27	32.47	49.37	-109.35	1132.1	999.3	1022.86	23.6	723.93
14	755.34	243	548.1	305.39	99	141.6	42.47	76	20.41	96.80	65.39	29.98	45.81	50.04	-182.84	1173.6	977.8	990.84	13.1	742.26
15	887.27	243	576.4	333.28	64	115.2	51.21	74	23.64	97.89	66.34	33.29	40.44	44.59	-222.77	1268.5	974.1	1045.83	71.8	815.49
16	929.76	242	611.8	369.41	64	116.4	52.92	77	18.05	94.64	67.74	41.27	51.86	47.64	-250.45	1312.2	1031.3	1061.83	30.5	899.27
17	923.36	242	623.3	380.95	64	104.8	41.23	77	18.76	95.55	72.00	43.59	52.27	55.39	-232.28	1306.1	1046.9	1073.91	27.0	896.34
18	959.25	243	669.4	426.70	87	101.0	14.30	82	35.54	117.16	76.74	45.30	58.46	61.66	-214.21	1370.3	1129.7	1156.19	26.5	932.79
19	956.12	243	738.8	496.07	128	201.5	73.75	82	78.01	159.85	95.29	50.63	72.45	73.32	9.06	1408.4	1391.8	1417.58	25.8	930.34
20	956.71	243	722.3	479.62	109	182.9	73.59	82	41.53	123.44	91.93	48.00	69.46	72.52	-61.23	1390.6	1310.5	1329.50	19.0	937.76
21	959.66	243	724.1	481.37	124	191.8	67.81	82	31.55	113.52	81.64	44.60	67.74	72.39	-83.70	1408.4	1295.8	1324.80	29.0	930.67
22	960.32	243	710.5	467.39	127	182.0	55.11	82	27.38	109.39	78.06	33.21	66.45	62.65	-136.15	1412.3	1242.2	1276.29	34.0	926.27
23	877.00	243	656.1	413.01	127	171.4	44.18	82	45.20	127.13	69.81	23.08	51.54	54.14	-167.15	1329.2	1153.2	1162.13	9.0	868.05
24	758.68	243	629.1	386.33	117	159.7	42.28	82	28.57	110.70	59.21	25.88	44.36	49.75	-88.59	1201.0	1078.6	1112.42	33.8	724.91
Max	960.32	243	738.8	496.07	128	201.5	146.31	82	78.01	159.85	95.29	50.63	72.45	73.32	9.06	1412.3	1391.8	1417.58	71.8	937.76
Min	737.86	242	548.1	305.39	30	101.0	14.30	67	8.08	76.94	28.80	17.57	30.78	38.58	-263.04	1113.1	972.2	990.84	9.0	717.88

ANNEXURES
&
EXHIBITS

RESERVOIR PARTICULARS OF THE MONTH :

Jul-10

Name of the Reservoirs	FRL	MDDL	Beginning of the month		End of the month	
			Level	Energy content(MU)	Level	Energy content(MU)
KHANDONG	719.3 M	704 M	718.75	23.00	717.55	21.00
KOPILI	609.5 M	592.83 M	600.65	35.00	605.32	67.00
LOKTAK	768.5 M	766.2 M	768.91	250.00	768.77	250.00
BARAPANI	3220 Ft	3150 Ft	3193.78	24.30	3196.62	26.80
GUMTI	93.55 M	83.6 M	88.70	11.00	89.00	12.00
DOYANG	333 M	306 M	320.15	25.00	324.05	36.50

FREQUENCY ANALYSIS FOR THE MONTH OF : Jul-10

Frequency	(Freq.in Hz)	(Time: H:M)	(Date:D.M.Y)
1. Maximum frequency	50.72	4:03	05.07.10
2. Minimum frequency	48.71	21:18	16.07.10
3. Monthly average	49.81		

Frequency in Hz as %age of time for the blocks :

f < 49.5	49.5 < f < 50.2	f > 50.2
9.88	84.27	5.85

Daily Frequency Variation Index :

DATE	FVI	DATE	FVI
01-Jul-10	1.000	17-Jul-10	3.710
02-Jul-10	1.201	18-Jul-10	1.060
03-Jul-10	0.660	19-Jul-10	1.620
04-Jul-10	0.350	20-Jul-10	0.360
05-Jul-10	0.590	21-Jul-10	0.910
06-Jul-10	0.320	22-Jul-10	0.290
07-Jul-10	0.270	23-Jul-10	0.890
08-Jul-10	0.570	24-Jul-10	0.890
09-Jul-10	3.044	25-Jul-10	0.310
10-Jul-10	0.250	26-Jul-10	0.947
11-Jul-10	0.420	27-Jul-10	0.680
12-Jul-10	0.370	28-Jul-10	1.920
13-Jul-10	0.510	29-Jul-10	2.250
14-Jul-10	0.370	30-Jul-10	1.600
15-Jul-10	1.370	31-Jul-10	0.230
16-Jul-10	3.991	Average FVI	1.063

Annexure-III

Details of Scheduled Bilateral Exchanges within the Region in

Jul-10

Sl.No.	From	To	Energy (At Seller Injn. Point) (MWH)		Energy (At State Periphery) (MWH)
1	Tripura(Baramura)	Manipur	3463.812500		3356.110938
2	Tripura(Baramura)	Mizoram	3463.812500		3356.110938
3	ASEB	POWERGRID^	241.669900	^ The actual energy consumed by POWERGRID	
4	MeECL	TSECL (NVVN)	40.000000		38.800000

Scheduled Bilateral Exchange with SEBs / Organisations in other Regions

Sl.No.	From	To	Energy (At Seller Periphery) (MWH)	Energy (At NER-ER Periphery) (MWH)	Energy (At Buyer Periphery) (MWH)
1	Ar. Pradesh	BRPL (AP)	1317.500000	1276.773000	
2	Ar. Pradesh	BSES (AP)	16200.000000	15698.160000	
3	APDCL	WBSEDCL (NVVN)	2112.500000	2049.462500	
4	APDCL	HPPC (NVVN)	7440.000000	7208.880000	
5	APDCL	HPPC (NVVN)	22320.000000	21626.640000	
6	MeECL	NDPL (NVVN)	7440.000000	7208.880000	
7	MeECL	NDPL (NVVN)	9920.000000	9611.840000	
8	MeECL	NDPL (NVVN)	3410.000000	3304.050000	
9	MeECL	NDPL (NVVN)	2046.000000	1982.430000	
10	Nag	Rajdhani (BSES)	15825.000000	15335.070000	
11	TSECL	NDPL (NVVN)	11160.000000	10813.130000	
12	NTPC DADRI (RF)	TSECL (NVVN)	54.000000	51.330000	49.690000
13	NTPC AURAIYA (RF)	TSECL (NVVN)	50.000000	47.330000	45.870000
14	Farakka*	Ar. Pradesh	1456.430625	1425.850000	1381.524875
15	Kahalgaon 1*	Ar. Pradesh	638.095500	623.100000	603.704575
16	Talcher*	Ar. Pradesh	812.062500	792.425000	767.881900
17	Farakka*	Assam	43059.756000	42084.100000	40775.851275
18	Kahalgaon 1*	Assam	12649.503125	12364.125000	11978.738400
19	Kahalgaon 2*	Assam	21945.662750	21454.775000	20784.332050
20	Talcher*	Assam	17310.309750	16921.025000	16396.985000
21	Farakka*	MeECL	5631.531750	5503.825000	5332.731675
22	Kahalgaon 1*	MeECL	2643.538500	2578.825000	2498.440625
23	Kahalgaon 2*	MeECL	6939.340000	6781.975000	6570.056625
24	Talcher*	MeECL	3139.975000	3069.050000	2974.003025
25	Farakka*	Nagaland	5895.899750	5759.325000	5580.296525
26	Kahalgaon 1*	Nagaland	2729.106	2677.525	2594.083625
27	Talcher*	Nagaland	3284.552875	3215.325000	3115.734500

Bilateral exchange through IEX Power Exchange (-ve means injection, +ve means drawal)

28	Arunachal Pradesh			96.200000	93.160000
29	Assam		-19121.240000	-18525.500000	
30	MeECL		-3879.640000	-3756.710000	
31	Mizoram		-1675.100000	-1626.000000	
32	Tripura		-14254.640000	-13811.700000	
33	Tripura			4205.750000	4076.100000

ENERGY EXCHANGE(in MU) IN NER DURING July, 2010

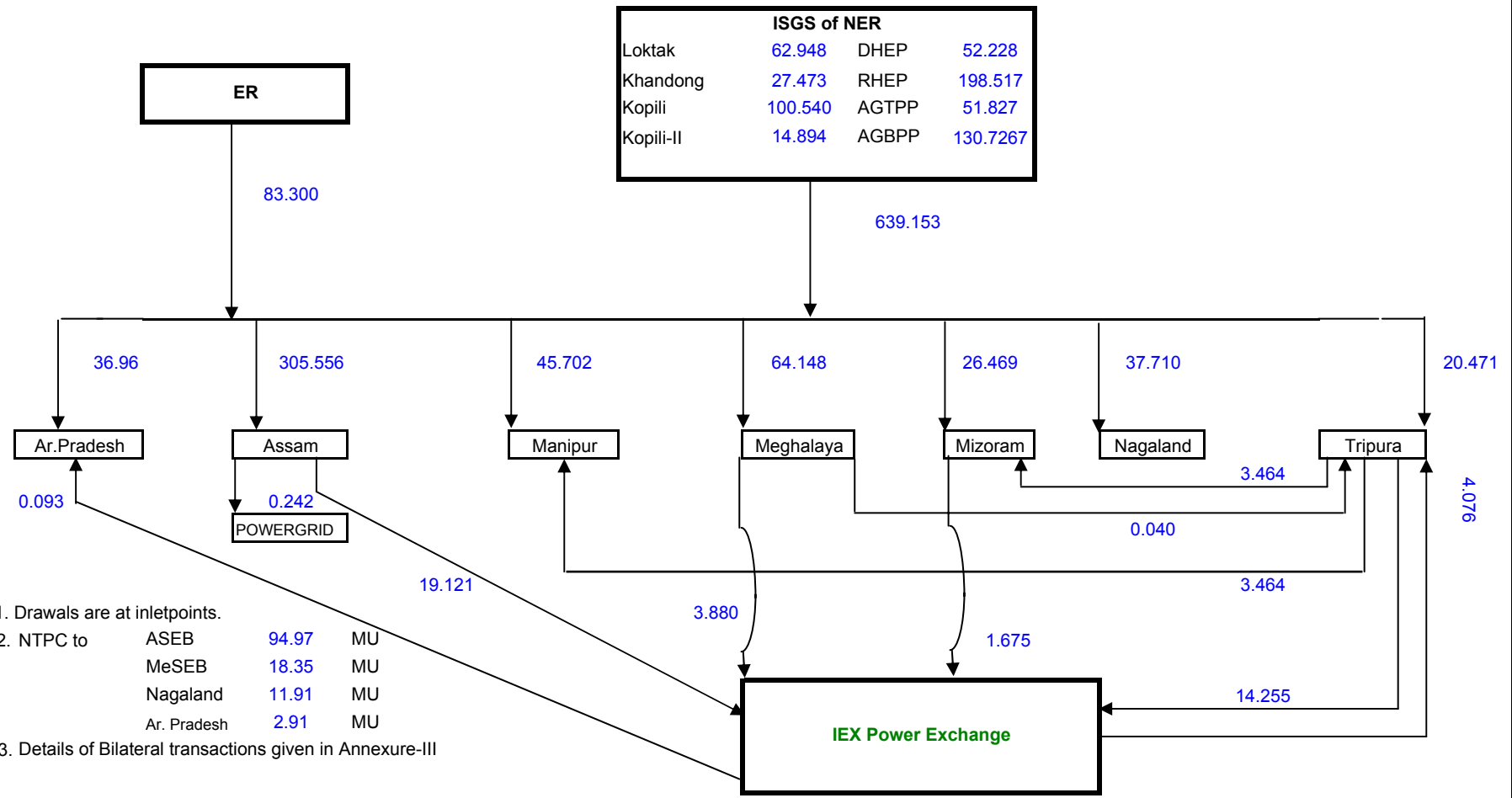

- N.B - 1. Drawals are at inletpoints.
 2. NTPC to
- | | | |
|-------------|-------|----|
| ASEB | 94.97 | MU |
| MeSEB | 18.35 | MU |
| Nagaland | 11.91 | MU |
| Ar. Pradesh | 2.91 | MU |
3. Details of Bilateral transactions given in Annexure-III

Frequency Duration for July, 2010

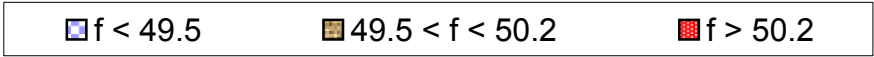
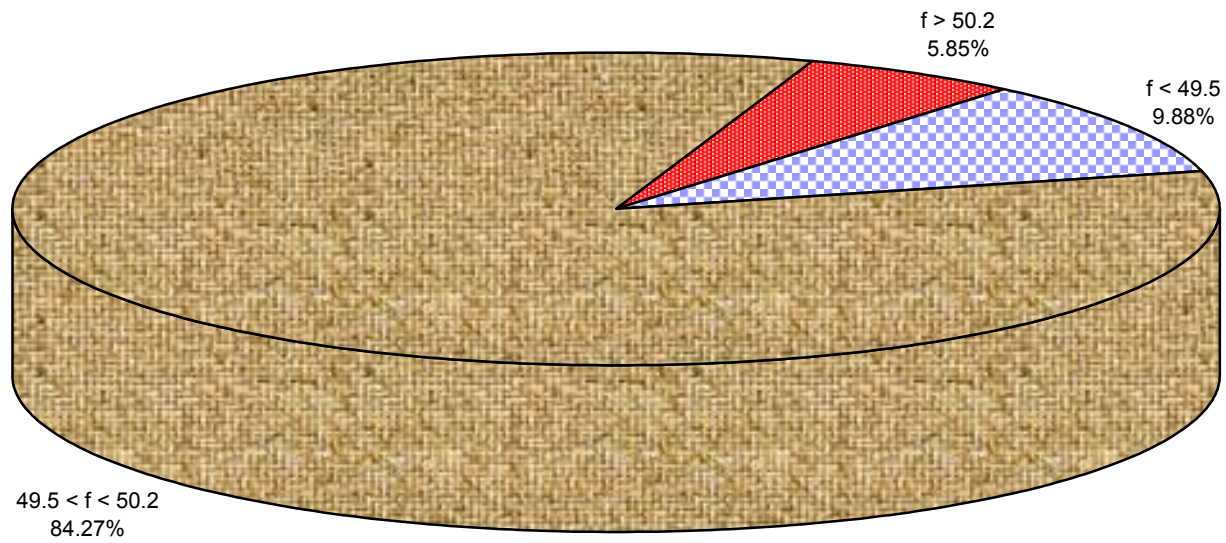

FVI Characteristics for July, 2010

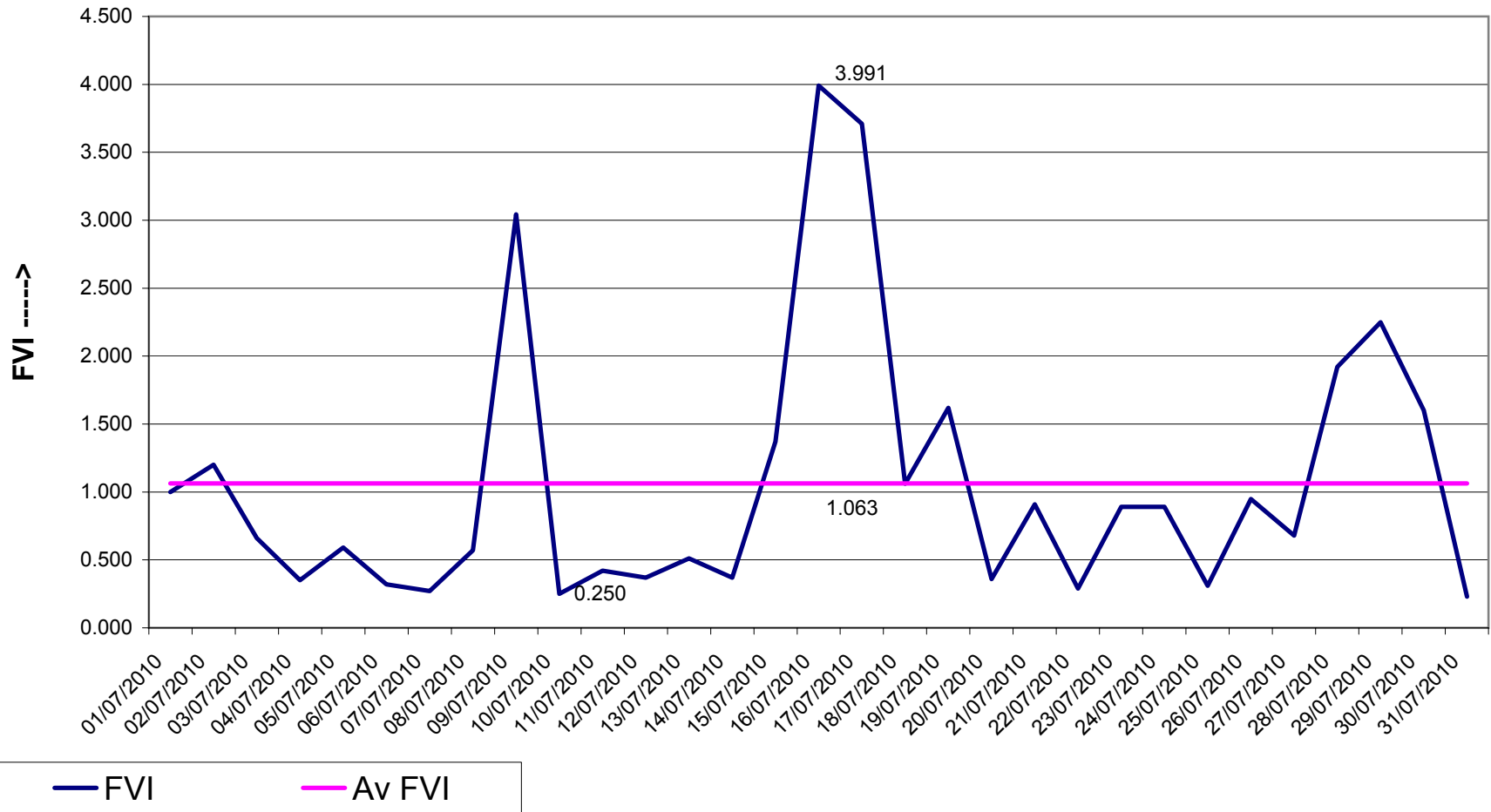

Maximum & Minimum Voltage Levels of Important Substations in NER during

July, 2010

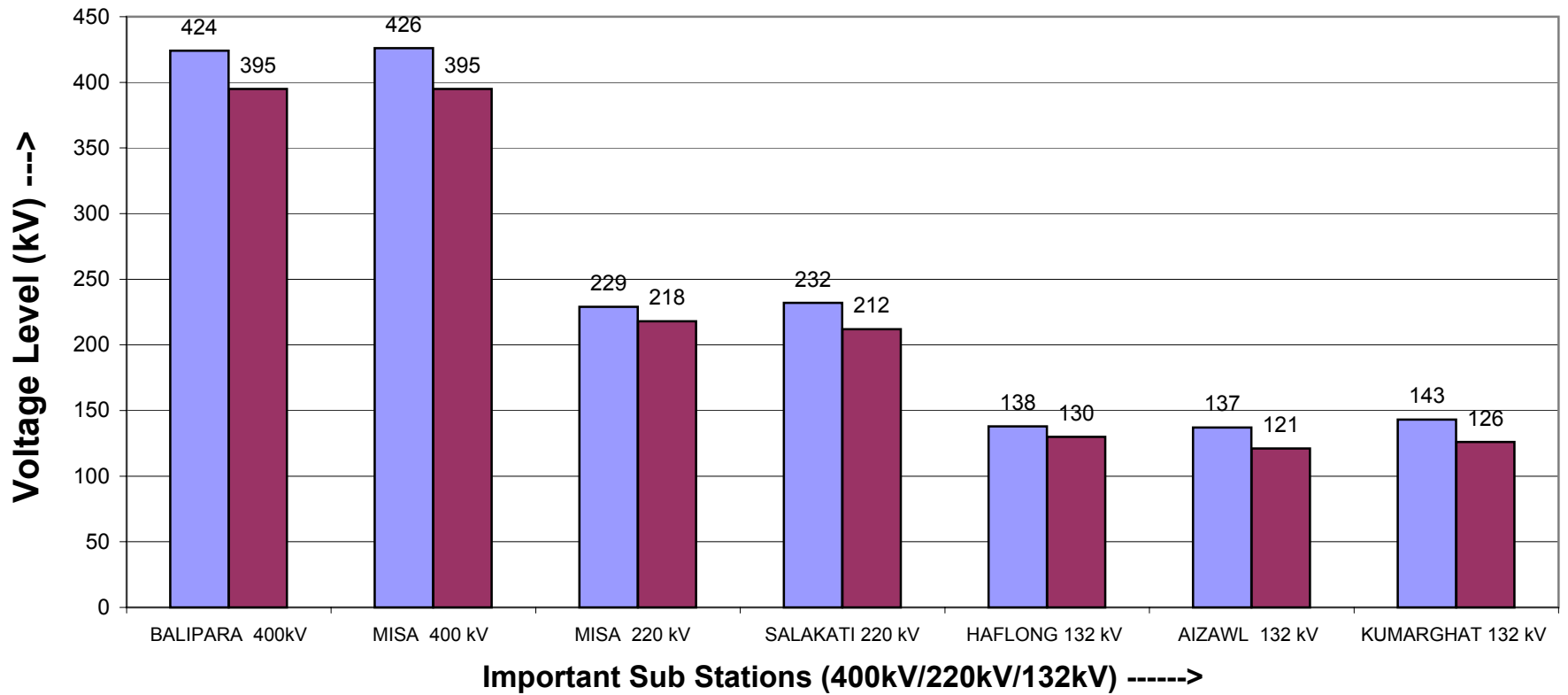

State and Central Sector Generation (MU) in NER in July, 2010

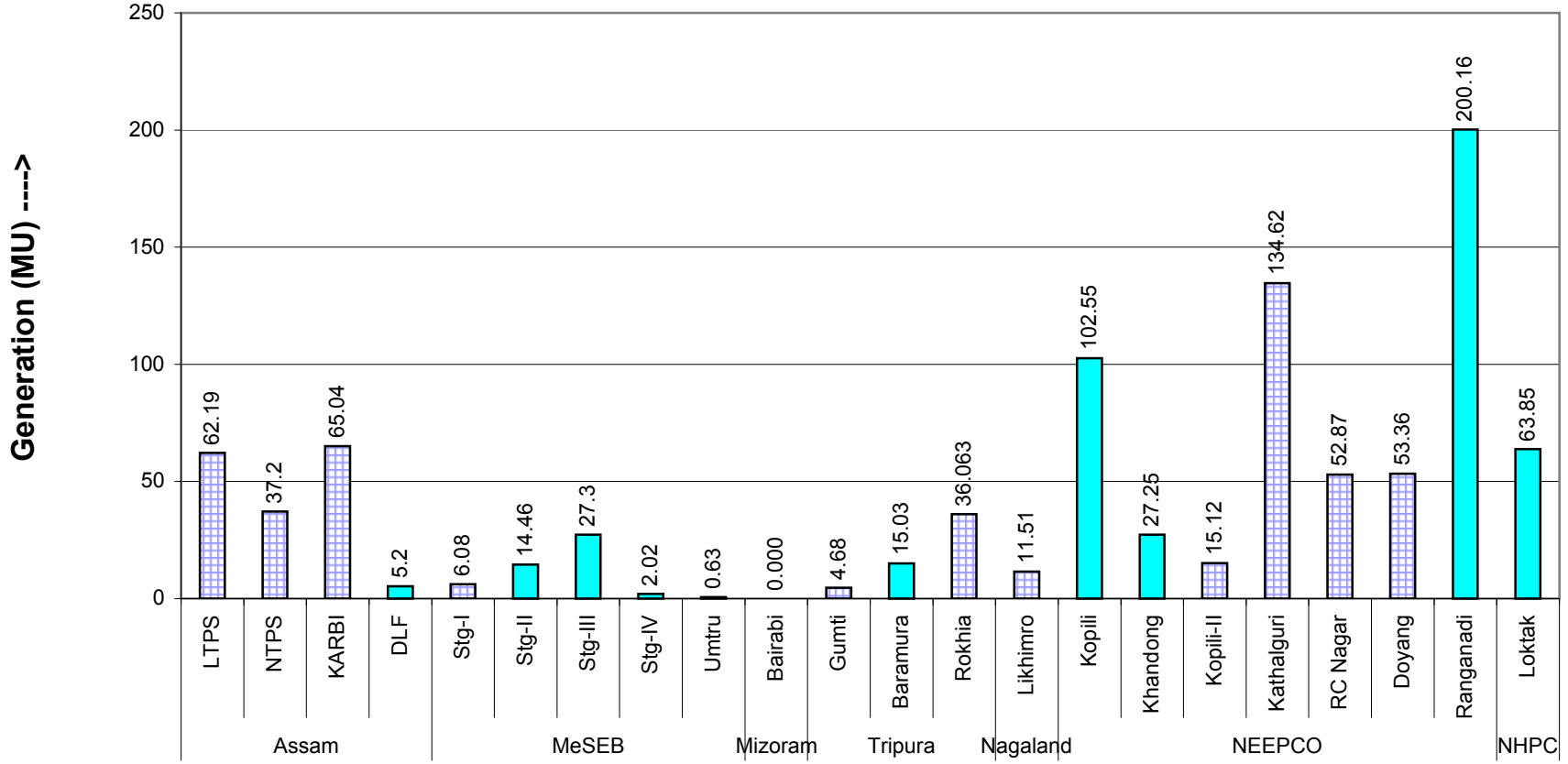

NER States Energy Scenario in July, 2010

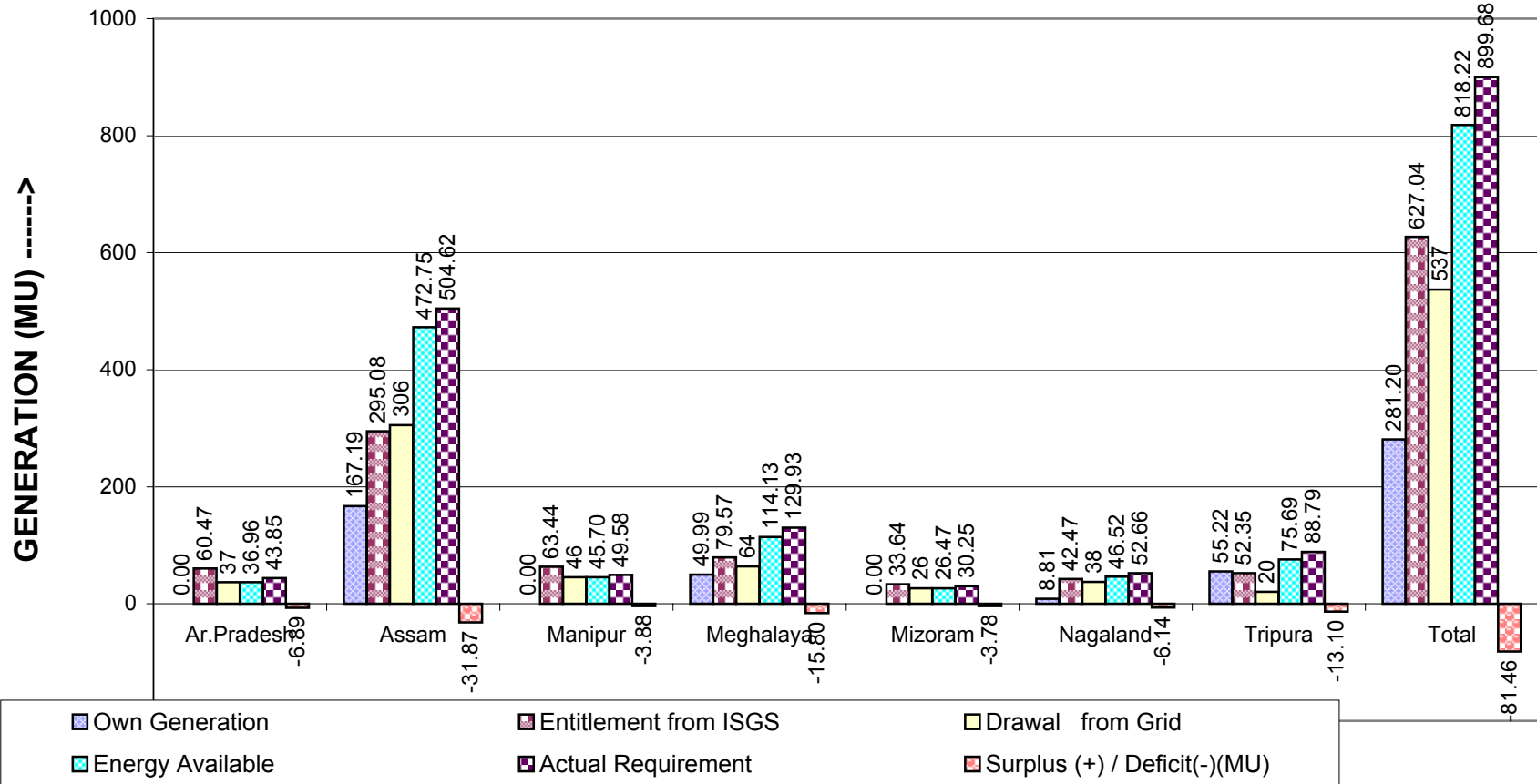

Reservoir Statistics of NER in July, 2010

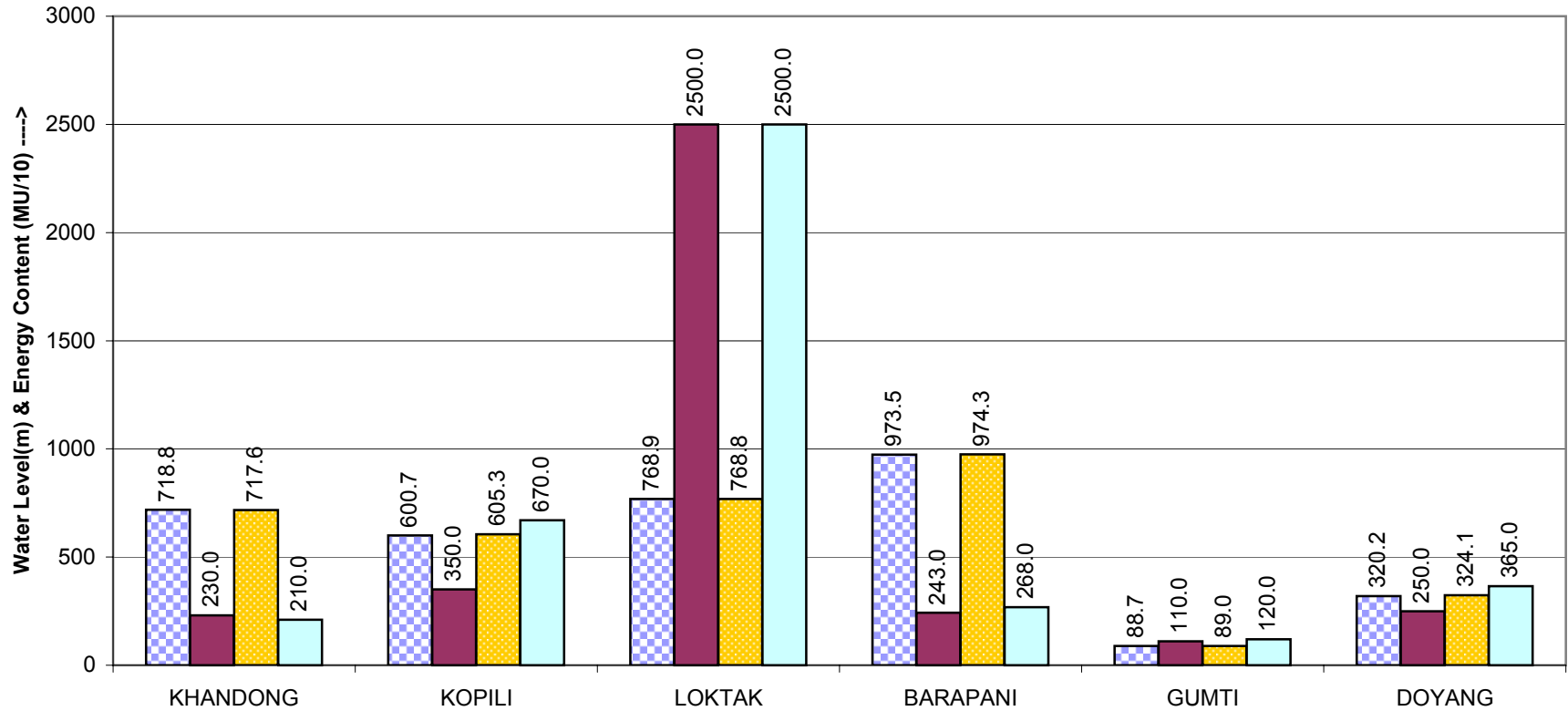

Beginning of the month Level
 Beginning of the month Energy content(MU)

End of the month Level
 End of the month Energy content(MU)