

भारत सरकार Government of India  
शक्ति विभाग Ministry of Power  
केंद्रीय बिजली प्राधिकार  
Central Electricity Authority

उत्तर-पूर्व क्षेत्रीय बिजली प्राधिकार  
**North Eastern Regional Power Committee**  
शिल्लॉंग Shillong

**Progress Report**

*For the month of*

**January, 2012**

<b>CONTENTS</b>		
<b>Sl. No.</b>	<b>Topics</b>	<b>Page No.</b>
1	Brief Highlights of North Eastern Regional Power System	1
2	Salient Features	2
<b><u>DETAILS OF THE REPORT</u></b>		
3	Monthly Power Supply Position:	
	(i) Energy generation in the Region	3
	(ii) Requirement Vs Availability in the Region	3
	(iii) Estimation of Peak Demand (MW)	4
	(iv) Estimation of Energy Requirement (MU)	4
4	Station wise Energy Generation (MU) & Peak Generation (MW):	
	(i) State Sector	5, 6
	(ii) Central Sector	7
5	Plant Load Factor (PLF)	8
6	Voltage Profile of Important Sub-Stations	8
7	(i) Inter Regional Energy Exchange	9
	(ii) Major Grid disturbances	9
	(iii) Meetings held by NERPC	9
8	Status of progress of:	
	(i) Generating Units	10
	(ii) Transmission Lines	11, 12
9	Commercial Status:	
	(i) UI Accounting	13
	(ii) Schedule and CS Share Allocation	14, 15
10	NER Grid Status on (i) Regional Peak Demand day	16
	(ii) Regional Minimum Demand day	17
<b><u>ANNEXURES</u></b>		
A-1	Major Reservoir Levels	I
A-2	Frequency Analysis and it's Profile	II
A-3	Scheduled Bilateral Exchanges	III
A-4	Energy Exchanges	IV
<b><u>EXHIBITS</u></b>		
B-1	Frequency Profile:	
	(i) Duration of frequency in different ranges	I
	(ii) Frequency Variation Index	II
B-2	Voltage Profile:	
	(i) Voltage Profile of Important Sub-Stations	III
B-3	Energy Generation:	
	(i) Energy Generation by Constituents during the month	IV
	(ii) Energy scenario of State's during the month	V
B-4	Reservoir profile :	
	(i) Reservoir statistics for the month	VI

## NORTH EASTERN REGIONAL POWER COMMITTEE

### *Brief highlights of North Eastern Regional Power System for the month of January, 2012*

- ❖ The maximum unrestricted demand during the month of **January, 2012** was **1699 MW**, which was **1767 MW** in the month of **December, 2011**. The peak demand met in NER during the period under review was **1620 MW**, which was **1648 MW** last month.
- ❖ The energy requirement during the month of **January, 2012** was **891.43 MU**, which was **871.46 MU** in the month of **December, 2011**. The energy availability in NER during the period under review was **807.90 MU**, which was **800.05 MU** last month.
- ❖ The maximum, minimum & average system frequency were **50.84, 48.99 & 49.91 Hz** respectively. The maximum, minimum & average FVI were **1.44, 0.31 & 0.736** respectively. The average FVI was **less** than its previous month's figure. (refer Annex-II).
- ❖ Maximum export of power from NER to ER was **49 MW (on 16/01/12 at 18:55 hrs)** and that from ER to NER was **642 MW (08/01/12 at 16:58 hrs)**. Total net energy import during the month was **273.26 MU (from ER)**.

**SALIENT FEATURES OF  
NORTH EASTERN REGIONAL GRID FOR JANUARY, 2012**

1	New unit/ transmission lines/Transformers commissioned during this month	<b>Nil</b>	
2	Number of total grid disturbance during this month	<b>Nil</b>	
		<b>Jan-12</b>	<b>Jan-11</b>
3	<b>Installed Capacity</b> of the Region ( in MW )(grid)	2133.32	2054.12
4	<b>Energy Generation in MU (Gross)::</b>		
	Thermal	429.734	433.279
	Hydel	139.379	214.254
	Diesel / Oil	0.000	0.000
	Total	569.114	647.533
5	<b>Demand in MW ::</b>		
	Registered Peak demand	1699.00	1667.00
	Peak demand met	1620.31	1547.00
	Shortage ( % age )	-4.63	-7.20
6	<b>Regional Energy(Gross) in MU ::</b>		
	Energy requirement	891.15	790.59
	Energy availability	807.90	744.68
	Surplus (+) / Deficit (-) ( % age )	-9.34	-5.81
7	<b>Inter Regional Energy Exchange in MU ::</b>		
	NER ----> ER	2.121	2.520
	ER ----> NER	275.385	169.191
	Net Import	273.264	166.67
8	<b>Frequency profile ::</b>		
	Average frequency ( Hz )	49.91	49.85
	Average Frequency Variation Index	0.736	0.678
9	Load Factor ( in % )	63.91	60.04

**ENERGY GENERATION IN THE REGION FOR THE MONTH OF Jan-12**

All figures in MU

Constituents	Hydro		Coal / Oil fired		Gas Based(OpenCycle)		Gas Based(Com Cycle)		Total(gen)	Total(gen)
	Gross	Net	Gross	Net	Gross	Net	Gross	Net	Gross	Net
	A	B	C	D	E	F	G	H	I	J
<b>State Sector :</b>										
Assam	16.635	16.469	0.000	0.000	83.677	82.840	53.437	51.834	153.749	151.143
Meghalaya	26.538	26.272	0.000	0.000	0.000	0.000	0.000	0.000	26.538	26.272
Mizoram	0.000	0.000	0.000	0.000	0.000	0.000	0.000	0.000	0.000	0.000
Tripura	1.440	1.426	0.000	0.000	71.015	70.305	0.000	0.000	72.455	71.730
Nagaland	2.780	2.752	0.000	0.000	0.000	0.000	0.000	0.000	2.780	2.752
Total ( State Sector )									255.522	251.898
<b>Central Sector :</b>										
NEEPCO :										
Khd+Kop+Kop-II	27.763	27.485	0.000	0.000	0.000	0.000	0.000	0.000	27.763	27.485
K'guri	0	0	0.000	0.000	0	0	172.454	167.281	172.454	167.281
RCNagar	0	0	0	0	59.150	58.559	0	0	59.150	58.559
Doyang	5.600	5.544	0	0	0	0	0	0	5.600	5.544
Ranganadi	34.348	34.005	0	0	0	0	0	0	34.348	34.005
NHPC :										
Loktak	24.614	24.368	0.000	0.000	0.000	0.000	0.000	0.000	24.614	24.368
Total ( Central Sector )									323.929	317.240
<b>Total NER</b>	<b>139.717</b>	<b>138.320</b>	<b>0.000</b>	<b>0.000</b>	<b>213.842</b>	<b>211.703</b>	<b>225.891</b>	<b>219.115</b>	<b>579.450</b>	<b>569.138</b>

**REQUIREMENT Vs AVAILABILITY IN THE REGION**

STATES	ENERGY requirement (MU) at 50 Hz				POWER requirement (MW) at 50 Hz			
	Availability & L/S at prevailing freq.				Availability & L/S at prevailing freq.			
	Requirt.	Availy.	Shortfall	%Shortfall	Requirt.	Availy.**	Shortfall	%Shortfall
Ar.Pr.	58.19	53.68	4.51	7.75%	100	96	4	3.75%
Assam	474.81	453.37	21.43	4.51%	985	953	32	3.29%
Manipur	38.12	34.61	3.51	9.21%	106	104	2	1.51%
M'laya	164.30	120.17	44.13	26.86%	273	267	6	2.26%
Mizoram	37.75	34.85	2.90	7.68%	75	73	2	2.55%
Nagaland	41.55	37.38	4.17	10.04%	106	102	4	3.89%
Tripura	76.43	73.83	2.59	3.39%	172	168	4	2.05%
<b>REGION</b>	<b>891.15</b>	<b>807.90</b>	<b>83.26</b>	<b>9.34%</b>	<b>1699</b>	<b>1620</b>	<b>79</b>	<b>4.65%</b>

**ESTIMATION OF PEAK DEMAND (in MW)**

Constituents	Peak Demand Met	Date	Freq. (Hz)	Freq. Corr.**	L/S	Estimated Peak demand at 50 Hz
Arunachal Pradesh	96.00	15/01/2012	50.09	-0.26	4	99.74
Assam	953.00	31/01/2012	49.81	5.43	27	985.43
Manipur	104.00	31/01/2012	49.81	0.59	1	105.59
Meghalaya	266.70	13/01/2012	49.64	2.88	3	272.88
Mizoram	73.00	02/01/2012	50.04	-0.09	2	74.91
Nagaland	102.00	17/01/2012	49.63	1.13	3	106.13
Tripura	168.00	11/01/2012	49.70	1.51	2	171.51
REGION	1620.31	14/01/2012	50.18	-8.75	88	1699.25

\*\* Freq.Correction = Demand met x 0.03 x ( 50 - Av. Freq.)

**ESTIMATION OF ENERGY REQUIREMENT (in MU)**

Average Frequency 49.91 Hz

Constituents	Generation	Energy drawal from grid			Over(+) / Under(-) Drawal	Energy Availability*	Freq. Corr.**	L / S	Actual Requirement
		Entitlement frm ISGS of NER	Entitlement frm ISGS of ER	Drawal					
Ar.Pr.	0.000	21.946	4.149	53.678	27.584	53.678	0.145	4.37	58.189
Assam	151.143	157.274	82.612	302.231	62.346	453.374	1.224	20.21	474.808
Manipur	0.000	30.316	0.000	34.612	4.296	34.612	0.093	3.42	38.125
M'laya	26.272	25.429	26.472	93.895	41.994	120.168	0.324	43.81	164.303
Mizoram	0.000	16.927	3.064	34.854	14.863	34.854	0.094	2.80	37.753
Nagaland	2.752	18.463	9.236	34.624	6.924	37.376	0.101	4.07	41.549
Tripura	71.730	27.954	0.000	2.103	-25.852	73.833	0.199	2.39	76.426
REGION	251.898	298.309	125.533	555.998	132.156	807.896	2.181	81.08	891.152

\*Energy availability means energy consumed by constituents

\*\* Freq.Correction = Demand met x 0.03 x ( 50 - Av.Freq.)

**ENERGY GENERATED (MU) AND PEAK GENERATION (MW) FROM GENERATING STATIONS/UNITS:**

Sl. No.	Power Stations / Units	Installed Capacity(MW)	Peak Generation(MW)	Energy Generation (MU)	
				Jan-12	Jan-11
<b>STATE SECTOR : HYDRO</b>					
<b>ASSAM :: HYDRO</b>					
1	KARBI HEP U - 1	50.00	50.20	8.527	11.480
2	KARBI HEP U - 2	50.00	50.20	8.108	7.720
TOTAL		100.00		16.635	19.200
<b>MEGHALAYA :: HYDRO</b>					
1	STAGE - 1	36.00	27.00	5.184	4.740
2	STAGE - 2	18.00	10.00	1.484	10.900
3	STAGE - 3	60.00	48.05	7.463	13.290
4	STAGE - 4	60.00	48.73	8.462	1.810
5	UMTRU	11.20	12.00	3.607	0.510
TOTAL		185.20		26.200	31.250
<b>NAGALAND :: HYDRO</b>					
6	LIKIMRO - 1				
7	LIKIMRO - 2	24.00	12.00	2.780	3.500
8	LIKIMRO - 3				
TOTAL		24.00		2.780	3.500
<b>TRIPURA :: HYDRO</b>					
9	GUMTI - 1	5.00	3.51	0.000	0.000
10	GUMTI - 2	5.00	4.36	0.000	2.899
11	GUMTI - 3	5.00	4.36	1.440	2.515
TOTAL		15.00		1.440	5.414
<b>TOTAL STATE (HYDRO) :</b>		324.20		47.055	59.364

**ENERGY GENERATED (MU) AND PEAK GENERATION (MW) FROM GENERATING STATIONS/UNITS:**

Sl. No.	Power Stations / Units	Installed Capacity(MW)	Peak Generation(MW)	Energy Generation (MU)	
				Jan-12	Jan-11
<b>STATE SECTOR : THERMAL/GAS</b>					
<b>MIZORAM ::Thermal</b>					
1	Bairabi	22.92	0.00	0.000	0.000
<b>TRIPURA :: THERMAL</b>					
1	BARAMURA - 1	5.00	Baramura Stn. Peak = 21.7 MW	0.000	0.000
2	BARAMURA - 2	5.00		0.000	0.000
3	BARAMURA - 3	6.50		0.000	0.000
4	BARAMURA - 4	21.00		15.565	15.336
5	BARAMURA - 5	21.00		15.515	15.475
6	ROKHIA - 1	8.00	Rokhia Stn. Peak = 47.9MW	0.000	0.000
7	ROKHIA - 2	8.00		0.000	0.000
8	ROKHIA - 3	8.00		0.000	5.326
9	ROKHIA - 4	8.00		4.499	4.413
10	ROKHIA - 5	8.00		0.000	0.000
11	ROKHIA - 6	8.00		5.251	0.000
12	ROKHIA - 7	21.00		14.261	15.345
13	ROKHIA - 8	21.00		15.924	15.030
	TOTAL	148.50		71.015	70.925
<b>ASSAM :: THERMAL</b>					
1	LTPS - 1	15.00	18	10.190	4.350
2	LTPS - 2	15.00	15.2	10.570	7.810
3	LTPS - 3	15.00	0.0	0.000	10.400
4	LTPS - 4	15.00	16.6	8.226	2.040
5	LTPS - 5	20.00	22.16	15.236	13.820
6	LTPS - 6	20.00	22.92	16.350	12.790
7	LTPS - 7	20.00	22.0	8.216	14.270
8	NTPS - 1	20.00	20.0	12.799	12.070
9	NTPS - 2	21.00	21.5	13.848	9.980
10	NTPS - 3	21.00	18.0	11.887	3.880
11	NTPS - 4	11.00	11.5	7.291	7.690
12	NTPS - 5	22.00	0.0	0.000	0.000
13	NTPS - 6	22.00	11.5	7.612	6.870
14	DLF	24.50	6.9	4.890	5.400
	TOTAL	261.50		127.115	111.370
TOTAL STATE THERMAL/GAS :		432.92		198.130	182.295
TOTAL SC GEN(HY+TH/GAS)		757.12		245.185	241.659

**ENERGY GENERATED (MU) AND PEAK GENERATION (MW) FROM GENERATING STATIONS/UNITS:**

Sl. No.	Power Stations / Units	Installed Capacity(MW)	Peak Generation(MW)	Energy Generation (MU)	
				Jan-12	Jan-11
<b>CENTRAL SECTOR : HYDRO</b>					
1	KHANDONG - 1	25.00	23.70	2.088	3.410
2	KHANDONG - 2	25.00	24.19	2.521	3.450
3	KOPILI Stg - II	25.00	22.25	1.691	0.870
4	KOPILI - 1	50.00	50.63	6.673	2.880
5	KOPILI - 2	50.00	55.80	6.379	19.230
6	KOPILI - 3	50.00	0.00	0.000	6.340
7	KOPILI - 4	50.00	50.70	8.411	20.620
8	DOYANG -1	25.00	25.72	2.070	2.190
9	DOYANG -2	25.00	21.21	2.344	1.770
10	DOYANG -3	25.00	22.22	1.185	3.060
11	LOKTAK - 1	35.00	36.53	4.720	0.000
12	LOKTAK - 2	35.00	37.35	4.114	25.430
13	LOKTAK - 3	35.00	37.97	15.780	25.560
14	RANGANADI - 1	135.00	140.61	11.339	23.840
15	RANGANADI - 2	135.00	138.82	13.199	16.240
16	RANGANADI - 3	135.00	141.06	9.810	0.000
<b>TOTAL HYDRO :</b>		<b>860.00</b>		<b>92.324</b>	<b>154.890</b>
<b>CENTRAL SECTOR : THERMAL/GAS</b>					
1	KATHALGURI - 1	33.50	35.15	20.646	23.420
2	KATHALGURI - 2	33.50	34.18	19.168	23.230
3	KATHALGURI - 3	33.50	35.39	24.290	24.050
4	KATHALGURI - 4	33.50	35.54	25.008	23.890
5	KATHALGURI - 5	33.50	35.39	23.985	23.340
6	KATHALGURI - 6	33.50	35.59	23.735	23.990
7	KATHALGURI - 7	30.00	0.00	0.000	17.210
8	KATHALGURI - 8	30.00	26.25	17.818	19.500
9	KATHALGURI - 9	30.00	26.55	17.805	18.480
10	R.C.NAGAR - 1	21.00	22.73	13.512	15.197
11	R.C.NAGAR - 2	21.00	23.34	15.168	10.582
12	R.C.NAGAR - 3	21.00	24.18	15.225	14.273
13	R.C.NAGAR - 4	21.00	23.51	15.245	13.822
<b>TOTAL THERMAL/GAS :</b>		<b>375.00</b>		<b>231.604</b>	<b>250.984</b>
<b>TOTAL CS ( HY + TH/GAS ) :</b>		<b>1235.000</b>		<b>323.929</b>	<b>405.874</b>
<b>TOTAL NER GEN(HY+TH/GAS) :</b>		<b>1992.120</b>		<b>569.114</b>	<b>647.533</b>

**Plant Load Factor (PLF) and Voltage Profile :**

Jan-12

**PLANT LOAD FACTOR OF THE THERMAL/ GAS STATIONS IN NER**

Sl. No.	Power Station	State/ Constituent	Installed Capacity (MW)	Generation (in MU)	Stationwise PLF (%)
1	LTPS*	AEGCL	120.00	68.788	77.05
2	NTPS*	AEGCL	117.00	53.437	61.39
3	Baramura	Tripura	58.50	31.080	71.41
4	Rokhia	Tripura	90.00	39.935	59.64
5	AGBPP	NEEPCO	291.00	172.454	<b>79.65</b>
6	AGTPP	NEEPCO	84.00	59.150	94.65

\*LTPS-- Lakwa Thermal Power Station, NTPS-- Namrup Thermal Power Station

**VOLTAGE PROFILE :**

**A. MAXIMUM AND MINIMUM VOLTAGE (kV ) OF IMPORTANT SUB - STATIONS :**

Sl. No.	NAME OF S/S	MAXIMUM ( kV )	MINIMUM ( kV )
1	BALIPARA 400 kV	425	370
2	MISA 400 kV	431	383
3	MISA 220 kV	234	210
4	SALAKATI 220 kV	220	213
5	HAFLONG 132 kV	141	125
6	AIZAWL 132kV	137	112
7	KUMARGHAT 132kV	137	122

**Voltage Range in kV as percentage of time for the block**

SUB-STATION	kV < 360	360<kV<380	380<kV<420	kV>420
MISA	0.00	0.00	95.08	4.92
BALIPARA	0.00	0.54	99.00	0.54

1 **INTER - REGIONAL EXCHANGE :**

All Fig in MU

NER to ER	2.121
ER to NER	275.385
NET IMPORT	273.264

2 **Major Grid Disturbances during this month**

Nil

3 **MEETING HELD BY NERPC DURING THIS MONTH**

1. 69th OCC Meeting was held on 10.01.12 at Guwahati.

2. 4th PCC meetings was held on 09.01.12 at Guwahati.

**PROGRESS OF GENERATION PROJECTS IN NER**

Name of the Generation Scheme	No. of Units	Capacity (MW)	Commissioning Schedule	REMARKS
<b>[A] NEEPCO</b>				
1. Monarchak TGBPP		104	2013	Activities in progress
2. Tuirial HEP Mizoram	2	2 X 30	WORKS HELD-UP	Being reviewed by PIB
3. Kameng HEP A. Pradesh	4	4X150	2014	Activities in progress
4. Tuival H.E. Proj. Mizoram	3	3X70	2015	Status not available
5. Tipaimukh HEP		1500	2015	Activities in progress
6. Mawphu HEP	2	90	2015	UNDER CCEA
7. Pare HEP, Ar. Pradesh		110	2015	UNDER CCEA
<b>[B] NHPC</b>				
a). Loktak Downstream HEP	2	66	2014	Activities in progress
b) Subansiri Lower HEP		2000	2013	Activities in progress
c) Siang Middle HEP		2000	2016	Activities in progress
d) Subansiri Upper HEP		2000	DPR Under prep	
e) Subansiri Middle HEP		1000	DPR Under prep	
f) Dibang Multipurpose Project		3000	Under TEC	
<b>[C] NTPC</b>				
a). Bongaigaon TPS	3	3X250	2012	Activities in progress
<b>[D] JV PROJECT</b>				
a). Palatana CCPP	2	2X323.3	2012	Activities in progress
<b>[E] ASSAM</b>				
(a) Lakwa WHRP		37.2	2012	Activities in progress
(b) Namrup CCPP	2	2X40	2014	
<b>[F] MIZORAM</b>				
(a) Tuivai Hydrel Project	2	51	2015	Activities in progress
(b) Bairabi Dam Project	2	2 X 40	2015	Activities in progress
<b>(G) MeECL</b>				
(a) Myntdu - Leishka HEP	2+1	3x42	2011-12	Activities in progress
(b) New Umtru HEP	2	2X20	2013	Activities in progress

<b>PROGRESS OF TRANSMISSION LINES IN NE REGION</b>									
	Name of the line	Length	Comm'n'g Sch		Total no. of locs .	Stubs com - pleted(nos)	Tower Erected	Stringing complt-ckm	Remarks
		(ckt kms)	Ann.pl	Ant/revd					
<b>A : Lines under ASEB.</b>									
1	132 kV, S/C Rangia - Sipajhar - Rowta- Depota	147							Work in progress
2	132 kV, S/C Sarusajai - Kahilipara	8							Work in progress
3	132 kV Nazira- Garmur (Mariani) S/C	63							Tender is in progress
4	220 kV Kathalguri - Tinsukia 2nd Ckt	50	2006-07						Work in progress
<b>B : Lines under Meghalaya :</b>									
1	132 kV Agia - Nangalbibra	110		2012					Work in progress
<b>C : Lines under Mizoram :</b>									
1	132 kV Khawzawl-E Lungdar S/C	48			100	100	76	0	Work in progress
2	132 kV Khawzawl-Ngopa S/C	57			117	117	117	57	Work in progress
3	132 kV Kolasib-Tuirial S/C	41			114	114	114	41(Conductor)	Work in progress
4	Kolasib-Sairul B D/C	25							Work in progress
5	132 kV Kolasib-Melriat S/C	90			369	Nil	Nil	Nil	Work in progress
6	132 kV Bairabi-Bawktlang S/C	30			93	91	85	14	Work in progress
7	132 kV Khawzawl-Champhai S/C	30			90	Nil	Nil	Nil	Work in progress
<b>D : Lines under NETC :</b>									
1	400 kV D/C Palatana - Silchar	1971	Aug-13	Sep-14	492	2591	1408	4	Matching with HVDC Converter
<b>E : POWERGRID Lines:</b>									
1	+/- 800kv HVDC Bipole Biswanath Chariyali - Agra	1971	Aug-13	Sep-14	4228	2591	1408	4	Matching with HVDC Converter
2	400kV Balipara - Biswanath Chariyali D/C	130	Aug-13	Aug-13	167	137	121	60	Matching with L. Subansiri
3	LILO of 400 kv Ranganadhi Balipara D/C at Biswanath	54	Aug-13	Aug-13	76	70	36	4	Matching with Gen. of L.Subansiri
4	132 kV D/C B. Chariyali-B. Chariyali (AEGCL)	32	Aug-13	Aug-13	55	21	2		
5	400 kV Kameng-Balipara D/C	110	Feb-13	Mar-14	142	54	4		Matching with Gen. of Kameng
6	400kV Balipara- Bongaigaon D/C line	596	Feb-13	Feb-13	838	778	557	160	Matching with Gen. of Kameng
7	400kV Lower Subansari-Biswanath Charrali line-I	334	Feb-13	Dec-13	444	297	213	38	Matching with Gen. Project
8	400kV Lower Subansari-Biswanath Charrali Line-II	340	Feb-13	Feb-13	442	314	195	30	Matching with Gen. Project
9	132 kV Kopili- Khandong-II	12	Sep-09	2011	43	37	24	8	Forest clearance awaited
10	400 kV D/C Bongaigaon TPS-Bongaigaon line	15	Mar-12		15	11	4		
11	400kV D/C Pallatana- Surajmani -nagar line	70	Dec-11	Mar-12	87	78	38		Copmpl. of Suraj-maninagar by TSECL
12	400kV D/C Silchar-Purba Kanchan Bari line	244	Mar-12	Jun-12	325	196	118	10	ROW problem
13	400kV D/C Silchar-Melriat(New) line	320	Dec-12	Mar-13	400	123	68		1 <sup>st</sup> Stg Forest clearance awaited
14	400kV D/C Silchar-Imphal(New) line	280	Dec-12	Jun-12	389	9			Likely to be delayed
15	220kV D/C Mariani(New)-Mokikchung(PG)	112	Dec-12	Mar-13	160	11			Efforts to be made to match U#2 of Palatana GBPP
16	132kV Silchar-Badarpur(PG) SW Interconnecting line	42	Nov-11		69	68	64	28	To match with U#1 of Palatana
17	132kV D/C Melriat(New)- Melriat (Mizo) Interconnecting line	60	Dec-12	Mar-13	85				Compl. Matching readiness of Melriat S/s by Mizoram
18	132kV D/C Silchar-Srikona (AEGCL) line	6	Dec-11	Jan-12	7	7	7	2	Engg. In progress
19	132kV D/C Silchar-Hailakandi (AEGCL) line	50	Dec-11	Mar-12			5		Completion matching with S/S
20	132kV D/C Mokikchung(PG)- Mokikchung(Naga) line	2	Dec-12	Mar-13	4				Efforts to be made to match U#2 of Palatana GBPP
21	132 kV S/C Pasighat-Roing line (on D/C)	70	Dec-12	Mar-13	550	62			Completion matching with S/S.
22	132 kV S/C Roing-Tezu line (on D/C)	60	Dec-12	Mar-13	550	62			Engg. in progress
23	132 kV S/C Tezu-Namsai line (on D/C)	90	Dec-12		180	8			Completion matching with S/S.
24	LILO of 400kV S/C Kathalguri -Misa line at Mariani(N)	2	Dec-12		20				
25	LILO of 132 kV S/C Loktak-Imphal line at Imphal (N)	60	Dec-12		150				

Name of the line	Length	Comm'ng Sch		Total no. of locs .	Stubs com - pleted(nos.)	Tower Erected	Stringing complt-ckm	Remarks
	(ckt kms)	Ann.pl	Ant/revd					
<b>F : Lines under Arunachal Pradesh</b>								
<b>i) Transmission Lines Plan works completed &amp; on going</b>								
1. 132 kV Nirjuli - Itanagar S/C (Under NLCPR)		2007-12				Completed	in progress	Work is in progress
2. 132 kV Along - Pasighat (Under NLCPR)		2007-12						Work is in progress
3. 132 kV Ranganadi - Itanagar S/C		2007-12						Work is in progress
<b>ii) Proposed for XIth Five Years Plan (State)</b>								
1. 132 kV Khupi - Seppa		2007-12						Work is in progress
2. 132 kV Line LILO at Bhalukpong		2007-12						Work is in progress
3. 132 kV Nirjuli - Banderdewa		2007-12						Work is in progress
4. 132 kV Along - Yingkiang		2007-12						Work is in progress
5. 132 kV Naharlagun - Seppa		2007-12						Work is in progress
6. 132 kV Roing - Anini		2007-12						Work is in progress
7. 132 kV Along - Reying		2007-12						Work is in progress
8. 132 kV Tezu - Roing		2007-12						Work is in progress
9. 132 kV Namsai - Tezu		2007-12						Work is in progress
10. 132 kV Ziro - Sangram		2007-12						Work is in progress
<b>iii) Proposed for XIth Five Years Plan (NLCPR)</b>								
1. 132 kV Pasighat - Roing		2007-12						Work is in progress
2. 132 kV Likabali - Gerukamukh		2007-12						Work is in progress
3. 132 kV Pasighat - Niglok		2007-12						Work is in progress
4. 132 kV Deomali - Khonsa		2007-12						Work is in progress
5. 132 kV Khupi - Banderdewa		2007-12						Work is in progress
6. 132 kV Banderdewa - Tawang		2007-12						Work is in progress
7. 132 kV Khonsa - Changlang		2007-12						Work is in progress
8. 132 kV Changlang - Jairampur		2007-12						Work is in progress
9. 132 kV Jairampur - Miao		2007-12						Work is in progress
10. 132 kV Itanagar - Seijusa		2007-12						Work is in progress
11. 132 kV Seijusa - Balipara		2007-12						Work is in progress
<b>iv) Proposed for XIth Five Years Plan (NEC)</b>								
1. 132 kV Niglok - Likabali		2007-12						Work is in progress
2. 132 kV Itanagar - Gohpur		2007-12						Work is in progress

**UI Receivable/ Payable for the month of****Jan-12**

Organisation	Actual (MU)	Schedule (MU)	UI Energy (MU)	UI Receivable (Rs. in Lakhs)	UI Payable (Rs. in Lakhs)
Arunachal Pradesh	53.678	30.546	23.133	0.000	706.486
ASEB	302.231	304.031	-1.800	106.006	58.542
Manipur	34.612	36.137	-1.525	21.591	24.714
MeSEB	93.895	68.786	25.109	0.000	775.578
Mizoram	34.854	25.612	9.242	0.000	330.821
Nagaland	34.624	27.184	7.439	0.000	265.982
Tripura	2.103	6.715	-4.612	68.256	4.609

**Entitlement, Schedule, Drawal and UI Charges****Jan-12**

Name of beneficiaries	Entit. from scheduled energy from ISGS in NER (Ex-PP State)	Entit. from scheduled energy from ISGS in ER (Ex-PP State)	Total Entitlement (Ex-PP State) (in MU)	Schedule (Ex-PP State) (in MU)	Actual Drawal from Grid (MU)	Over Drawal (+) / Under Drawal (-) (MU)	UI Payable (-)/ Receivable (+) (Rs. In Cr)
Arunachal Pradesh	21.946	4.149	26.094	30.546	53.678	23.133	-7.065
ASEB	157.274	82.612	239.885	304.031	302.231	-1.800	0.475
Manipur	30.316	0.000	30.316	36.137	34.612	-1.525	-0.031
MeSEB	25.429	26.472	51.901	68.786	93.895	25.109	-7.756
Mizoram	16.927	3.064	19.991	25.612	34.854	9.242	-3.308
Nagaland	18.463	9.236	27.699	27.184	34.624	7.439	-2.660
Tripura	27.954	0.000	27.954	6.715	2.103	-4.612	0.636

( Source : UI A/c, NERPC )

**Schedule for ISGS's Generation and State's Draw for the month of**

**Jan-12**

States	Schedule From ISGS(MWH)	Bilateral Schedule from Outside NER ( MWH )	Total Schedule ( MWH )	Ex.PP. Drawal ( MWH )	Tr. Energy ( MWH )
Arunachal Pradesh	22286.76	4268.05	26554.81	57010.44	57010.44
ASEB	160534.38	84983.33	245517.71	320990.36	320990.36
Manipur	30865.90		30865.90	36560.05	36560.05
MeSEB	28460.59	27231.63	55692.22	99723.60	99723.60
Mizoram	17245.09		17245.09	37017.66	37017.66
Nagaland	18869.58	9501.75	28371.33	36018.25	36018.25
Tripura	28184.73		28184.73	2233.50	28184.73
<b>Total</b>	<b>306447.04</b>	<b>125984.75</b>	<b>432431.79</b>	<b>589553.86</b>	<b>615505.09</b>

ISGS	Schedule ( MWH )	Injection ( MWH )
LOKTAK	23727.05	23861.81
KHANDONG	4293.31	4296.51
KOPILI-I	20935.16	21368.68
KOPILI-II	1637.80	1623.94
DHEP	5110.34	5105.51
RHEP	33501.23	33109.95
AGTPP	57716.83	58144.77
AGBPP	159525.34	168778.50
<b>Total</b>	<b>306447.04</b>	<b>316289.66</b>

Source : Provisional REA for the month: Jan-12

**Cumulative wt. Average Share Allocation (%) ( Up to this month) in CS Stations**

States	KOPILI	KOPILI-II	KHANDONG	RHEP	DHEP	AGBPP	AGTPP	Loktak HEP
	(200 MW)	(25 MW)	( 50 MW)	(405 MW)	(75 MW)	(291 MW)	( 84 MW)	( 90 MW)
Arunachal Pradesh	5.191	5.992	4.194	18.462	6.852	5.694	6.132	4.940
Assam	53.455	52.355	56.285	43.328	43.808	56.503	45.585	29.445
Manipur	7.395	6.945	6.555	8.373	7.865	8.105	8.313	30.115
Meghalaya	17.395	13.675	16.905	11.505	11.455	11.815	11.813	12.393
Mizoram	4.610	6.040	3.940	5.700	5.250	5.410	5.980	5.020
Nagaland	6.147	5.735	6.653	5.335	17.967	5.805	5.377	6.435
Tripura	5.807	9.258	5.468	7.297	6.803	6.668	16.800	11.652
Total	100.00	100.00	100.00	100.00	100.00	100.00	100.00	100.00

**Details of Fixed and Energy Charges of CS Stations for FY 2011-12**

Projects	Installed Capacity ( MW )	Design Energy (GWh )	Annual Fixed Charge ( Rs. Crore)	Reference
KOPILI HEP	200	1186.14*	75.1117 *	*As per CERC order dated 30.09.2011 in petition No 294/2009.
KOPILI -II	25	86.3*	12.9511 **	* Provisional, ** As per CERC order dated 01.01.08 in pet. No 70/2006
KHANDONG HEP	50	277.61*	33.886 *	*As per CERC order dated 30.09.2011 in petition No 297/2009.
RHEP*	405	1509.69	290.7301	*As per CERC order dated 10.05.2011 in petition No.296/2009.
DHEP	75	227.24	58.5 *	*As per CERC order dated 03.10.07 in petition No 88/2007.
AGBPP	291	NA	233.81 *	As per CERC order dated 6.9.2011 in Pet.No295 / 2009
AGTPP	84	NA	67.9814 *	Base Rate of energy Charge as per the CERC Order *As per CERC order dated 11.03.11 in Pet.No 299/2009,^Base Engy. charge as per CERC order
LOKTAK HEP	105	448.00	95.7935 *	*As per CERC order dated 14.06.11 in Pet.No 108/2010

## HOURLY DATA ON PEAK DEMAND MET DAY

DATE:- 29.01.2012

All figures in MW

HRS.	Total ISGS Injection (MW)	STATE SECTOR													ER					Total Drawal by States
		ASEB			MeSEB			Tripura			Manipur	Mizoram	Nagaland	ArPr		Total N.E.R GEN	Total Demand Met	Gross Demand met	Actual Loss	
		GEN	Drawal	Demand Met	GEN	Demand Met	Drawal	GEN	Demand Met	Drawal	DM	DM	DM	DM						
1	327.99	163	354.60	517.2	37	137.3	174.55	97	-12.8	84.20	27.17	35.12	32.00	72.55	366.62	624.80	808.56	857.14	48.6	279.40
2	334.24	161	342.94	503.7	28	120.7	148.85	97	-17.6	78.95	23.88	33.45	35.59	71.33	320.95	619.79	771.00	815.92	44.9	289.33
3	325.11	159	357.27	516.4	4	115.9	120.09	96	-19.0	77.12	23.93	32.86	31.35	75.49	340.25	584.58	776.96	824.47	47.5	277.60
4	334.83	161	358.83	520.1	4	112.1	116.25	96	-19.0	77.41	23.63	31.71	35.83	71.57	329.52	596.77	775.89	825.60	49.7	285.12
5	341.41	162	368.84	530.9	4	98.1	102.29	96	-18.3	78.04	24.77	32.86	33.72	76.32	328.05	604.03	778.43	831.51	53.1	288.32
6	337.07	165	383.73	549.2	4	131.0	135.23	96	-14.0	82.20	43.40	39.44	43.53	78.67	414.94	602.88	871.29	917.41	46.1	290.95
7	340.47	165	401.00	565.6	4	137.6	141.85	96	-5.0	91.36	42.75	60.05	49.63	84.16	475.20	605.62	934.78	980.20	45.4	295.06
8	344.28	206	377.37	583.4	37	137.4	174.79	96	4.7	100.87	44.37	47.04	49.76	79.87	437.13	683.92	946.56	987.43	40.9	303.42
9	338.47	165	380.62	545.2	71	120.6	191.18	97	2.2	98.75	42.41	46.73	49.16	73.03	412.23	670.22	879.36	915.27	35.9	302.56
10	331.72	162	360.67	522.7	71	103.5	174.09	97	-5.0	91.82	49.43	39.67	45.66	69.75	368.72	661.12	825.66	862.37	36.7	295.00
11	318.18	161	356.06	516.9	71	108.4	179.09	96	-13.7	81.92	46.16	38.79	39.98	59.73	372.16	645.37	796.25	851.15	54.9	263.28
12	319.44	158	354.04	512.2	62	100.5	162.26	95	-21.5	73.91	36.50	44.16	43.08	66.87	359.37	634.80	781.88	836.98	55.1	264.35
13	314.47	157	343.52	500.6	37	119.3	156.62	96	-24.6	71.16	31.18	43.13	42.68	66.35	357.51	604.59	778.61	828.97	50.4	264.11
14	312.23	157	331.01	488.1	37	114.1	151.09	95	-30.6	64.75	31.17	43.75	44.39	67.87	345.08	601.58	758.80	814.31	55.5	256.72
15	319.46	159	328.27	486.8	28	130.8	158.64	95	-27.7	67.35	26.28	53.08	45.83	68.26	358.91	600.96	783.34	836.88	53.5	265.91
16	315.49	159	338.66	497.8	24	119.0	143.14	95	-18.2	77.13	30.64	60.52	46.24	69.52	378.81	594.07	805.62	853.43	47.8	267.68
17	548.13	208	414.52	622.4	0	137.4	137.38	96	4.0	99.77	37.63	62.16	55.88	91.56	333.90	851.77	1010.92	1089.76	78.8	469.29
18	620.74	247	598.79	845.9	0	132.0	131.99	95	48.5	143.96	49.76	69.97	64.00	107.10	495.32	963.32	1317.23	1363.08	45.9	574.89
19	800.24	249	604.66	853.7	25	141.2	165.95	96	58.9	154.71	85.85	61.32	62.14	109.82	382.49	1169.85	1372.97	1431.70	58.7	741.51
20	867.05	249	615.38	864.7	25	139.4	164.14	96	52.2	147.85	86.67	62.05	63.74	104.95	306.25	1236.77	1373.62	1422.48	48.9	818.18
21	699.95	250	601.16	851.1	24	135.0	159.13	96	46.0	141.71	92.63	60.49	60.46	100.56	444.97	1069.68	1346.33	1394.77	48.4	651.50
22	621.99	209	534.48	743.0	36	150.4	186.68	97	30.0	126.51	88.74	51.00	49.24	94.84	436.65	963.34	1207.24	1267.10	59.9	562.14
23	412.57	166	422.78	589.0	54	133.4	187.58	96	1.8	98.28	75.52	42.28	38.00	70.20	423.91	729.50	950.22	1002.69	52.5	360.10
24	341.47	165	370.77	535.7	38	123.5	161.03	97	-12.4	84.24	69.97	36.52	37.58	65.67	399.87	640.64	856.52	906.25	49.7	291.74
<b>Max</b>	867.05	250	615.38	864.66	71	150.4	191.18	97	58.9	154.71	92.63	69.97	64.00	109.82	495.32	1236.77	1373.62	1431.70	78.8	818.18
<b>Min</b>	312.23	157	328.27	486.84	0	98.1	102.29	95	-30.6	64.75	23.63	31.71	31.35	59.73	306.25	584.58	758.80	814.31	35.9	256.72

## HOURLY DATA ON **MINIMUM DEMAND MET DAY**

DATE: 02.01.2012

All figures in MW

HRS.	Total ISGS Injection (MW)	STATE SECTOR													ER	Total N.E.R GEN	Total Demand Met	Gross Demand met = Sum of demand met of all the states+loss	Actual Loss	Total Drawal by States
		ASEB			MeSEB			Tripura			Manipur	Mizoram	Nagaland	ArPr						
		GEN	Demand Met	Drawal	GEN	Demand Met	Drawal	GEN	drawal	Demand Met	DM	DM	DM	DM						
1	319.73	225	313.7	538.48	0	122.6	122.60	86	-5.43	80.82	14.18	30.37	35.96	65.30	307.36	630.8	663.0	713.29	50.3	269.40
2	335.81	227	310.4	537.34	0	120.3	120.33	86	-6.97	79.29	9.16	29.28	40.97	63.13	277.67	649.0	652.5	699.67	47.1	288.69
3	340.77	183	293.2	475.88	0	116.2	116.24	86	-0.65	85.60	7.52	28.77	35.58	61.70	245.66	609.7	628.6	672.63	44.0	296.74
4	340.24	181	285.2	466.14	0	113.7	113.71	86	5.09	91.39	8.48	29.15	36.92	63.28	225.72	607.5	628.2	652.19	24.0	316.22
5	326.37	176	290.3	466.50	0	123.5	123.52	86	3.38	89.70	11.97	29.40	34.57	64.27	272.58	588.9	643.8	685.20	41.4	284.94
6	352.85	167	320.6	487.68	0	123.5	123.52	72	-6.60	64.99	24.64	37.04	40.09	61.79	301.96	591.6	672.6	718.64	46.0	306.84
7	448.77	174	322.9	497.30	0	101.7	101.72	75	-11.69	62.81	38.02	54.85	47.14	66.81	212.46	697.7	694.3	735.67	41.4	407.36
8	442.63	176	345.3	521.74	0	102.7	102.72	75	-2.42	72.20	46.44	61.49	54.23	65.64	273.79	693.6	748.1	790.97	42.9	399.72
9	337.69	218	345.0	562.53	0	100.6	100.64	75	1.21	75.89	36.16	56.97	36.99	60.79	340.13	629.9	712.4	752.44	40.0	297.69
10	339.01	212	298.3	510.76	24	93.9	118.34	95	-2.11	92.95	46.50	55.94	46.07	59.27	296.44	671.0	692.9	730.44	37.6	301.45
11	337.29	195	289.9	484.47	25	87.4	111.96	95	-8.70	86.29	41.05	52.34	38.11	54.22	258.03	651.4	649.3	690.24	40.9	296.39
12	340.21	197	316.5	513.12	49	116.6	166.11	95	-11.12	84.09	32.98	49.32	46.01	44.13	295.58	681.5	689.7	730.93	41.2	298.96
13	339.43	208	373.0	581.02	70	125.4	194.94	95	-12.54	82.22	44.91	49.16	38.80	59.22	377.24	711.8	772.7	811.36	38.6	300.78
14	335.16	206	369.8	575.56	63	128.4	191.57	95	-13.19	81.89	55.11	50.92	42.30	58.24	396.08	699.2	786.6	826.25	39.6	295.54
15	336.70	163	383.4	546.40	57	129.9	187.09	95	-9.54	85.46	39.46	47.09	37.92	59.24	398.48	651.9	782.4	830.12	47.7	289.03
16	338.43	162	387.9	549.56	57	91.6	148.91	95	3.48	98.51	42.57	51.08	45.55	63.31	396.19	652.4	780.5	829.59	49.1	289.37
17	557.17	149	500.4	649.35	57	86.4	143.73	95	40.78	135.94	39.04	61.06	53.30	94.54	305.88	858.6	970.7	958.07	-12.6	569.79
18	758.96	157	673.3	829.84	66	120.6	186.91	96	31.37	127.26	60.03	66.61	56.58	104.79	411.87	1077.7	1209.2	1266.58	57.4	701.59
19	858.59	201	666.2	866.91	42	123.8	165.72	96	43.64	139.28	82.70	63.72	50.31	109.55	337.38	1196.8	1235.6	1291.48	55.9	802.71
20	871.23	199	678.2	877.21	43	150.9	193.63	96	47.71	143.53	86.61	60.51	50.61	111.20	349.08	1208.8	1281.5	1315.99	34.5	836.76
21	650.25	202	567.6	769.84	40	117.4	157.80	96	39.24	135.09	85.89	55.14	51.24	104.90	394.27	988.8	1117.2	1140.23	23.0	627.22
22	592.44	218	490.3	708.45	40	113.6	153.99	96	17.36	113.75	83.90	50.77	39.60	97.51	334.65	947.4	989.4	1023.35	34.0	558.48
23	456.25	219	334.0	552.79	47	113.8	160.68	96	-5.38	91.03	78.55	43.83	32.78	70.22	277.63	818.3	764.2	830.22	66.0	390.24
24	316.94	217	314.2	531.04	42	127.2	169.64	96	-20.18	76.15	70.13	36.65	30.97	68.18	353.31	672.5	723.6	766.52	43.0	273.99
<b>Max</b>	871.23	227	678.2	877.21	70	150.9	194.94	96	47.71	143.53	86.61	66.61	56.58	111.20	411.87	1208.8	1281.5	1315.99	66.0	836.76
<b>Min</b>	316.94	149	285.2	466.14	0	86.4	100.64	72	-20.18	62.81	7.52	28.77	30.97	44.13	212.46	588.9	628.2	652.19	-12.6	269.40

*ANNEXURES*  
&  
*EXHIBITS*

RESERVOIR PARTICULARS OF THE MONTH :

Jan-12

Name of the Reservoirs	FRL	MDDL	Beginning of the month		End of the month	
			Level	Energy content(MU)	Level	Energy content(MU)
KHANDONG	719.3 M	704 M	715.70	17.08	714.50	14.49
KOPILI	609.5 M	592.83 M	598.73	23.60	598.63	22.40
LOKTAK	768.5 M	766.2 M	767.67	71.75	767.47	57.00
BARAPANI	3220 Ft	3150 Ft	3190.40	21.19	3185.84	18.03
GUMTI	93.55 M	83.6 M	84.00	1.52	84.00	1.52
DOYANG	333 M	306 M	317.05	17.00	314.91	11.80

**FREQUENCY ANALYSIS FOR THE MONTH OF : Jan-12**

Frequency	( Freq.in Hz )	( Time: H:M )	( Date:D.M.Y )
1. Maximum frequency	50.84	04:02	02-Jan-12
2. Minimum frequency	48.99	19:08	19-Jan-12
3. Monthly average	49.91		

**Frequency in Hz as %age of time for the blocks :**

f < 49.5	49.5 < f < 50.2	f > 50.2
3.0%	91.4%	5.7%

**Daily Frequency Variation Index :**

DATE	FVI	DATE	FVI
1-Jan-12	0.450	17-Jan-12	0.740
2-Jan-12	1.310	18-Jan-12	0.670
3-Jan-12	1.310	19-Jan-12	1.000
4-Jan-12	1.440	20-Jan-12	0.710
5-Jan-12	1.440	21-Jan-12	0.840
6-Jan-12	0.620	22-Jan-12	0.460
7-Jan-12	0.620	23-Jan-12	0.740
8-Jan-12	0.400	24-Jan-12	0.900
9-Jan-12	0.680	25-Jan-12	0.650
10-Jan-12	0.530	26-Jan-12	0.430
11-Jan-12	0.720	27-Jan-12	0.430
12-Jan-12	1.200	28-Jan-12	0.480
13-Jan-12	1.030	29-Jan-12	0.410
14-Jan-12	0.530	30-Jan-12	0.450
15-Jan-12	0.310		
16-Jan-12	0.690	<b>Average FVI</b>	<b>0.736</b>

**Annexure-III**

**Details of Scheduled Bilateral Exchanges within the Region in**

**Jan-12**

Sl.No.	From	To	Energy ( At Seller Injn. Point) (MWH)		Energy ( At State Periphery) (MWH)
1	Tripura (Baramura-IV)	Manipur	-3520.875000		-3327.119137
2	Tripura (Baramura-IV)	Mizoram	-3520.875000		-3327.119137
3	Tripura (Baramura-V)	Manipur	-3534.000000		-3339.532188
4	Tripura (Baramura-V)	Mizoram	-3534.000000		-3339.532188
5	TSECL	Mizoram (TSECL)	-215.880000		-210.000000
6	ASEB	POWERGRID^	194.941400	^ The actual energy consumed by POWERGRID	

**Scheduled Bilateral Exchange with SEBs / Organisations in other Regions**

Sl.No.	From	To	Energy ( At Seller Periphery) (MWH)	Energy ( At NER-ER Periphery) (MWH)	Energy ( At Buyer Periphery) (MWH)
1	BALCO	APDCL (PTCL)	41719.612500	40555.965000	
2	JPL	APDCL (KISPL)	21595.305000	20988.480000	
3	Farakka*	Ar. Pradesh	2249.274850	2199.500000	2138.084063
4	Kahalgaon 1*	Ar. Pradesh	779.765750	760.800000	739.594238
5	Talcher*	Ar. Pradesh	1330.144500	1307.750000	1271.219638
6	Farakka*	Assam	22924.684550	22538.775000	21909.412275
7	Kahalgaon 1*	Assam	6701.737875	6586.075000	6402.515188
8	Kahalgaon 2*	Assam	45032.937400	44286.000000	43050.551800
9	Talcher*	Assam	11734.350000	11572.475000	11249.205950
10	Farakka*	MeECL	6996.881450	6876.950000	6684.923400
11	Kahalgaon 1*	MeECL	2411.343500	2367.125000	2301.149850
12	Kahalgaon 2*	MeECL	14239.664000	14009.075000	13618.265975
13	Talcher*	MeECL	4035.292250	3978.475000	3867.339850
14	Farakka*	Nagaland	5045.946850	4961.550000	4823.000488
15	Kahalgaon 1*	Nagaland	1731.973500	1700.850000	1653.450838
16	Talcher*	Nagaland	2879.777500	2839.350000	2760.036625
17	Farakka*	Mizoram	1660.529250	1639.850000	1594.058475
18	Kahalgaon 1*	Mizoram	575.411500	565.175000	549.421713
19	Talcher*	Mizoram	956.632500	947.025000	920.569188

**Bilateral exchange through IEX Power Exchange (-ve means injection, +ve means drawal)**

20	Ar. Pradesh			5209.300000	5063.470000
21	Assam		-10802.230000	-10500.000000	
22	Assam			18300.000000	17791.520000
23	MeECL		-715.440000	-695.500000	
24	Mizoram		-777.740000	-756.000000	
25	Tripura		-6272.470000	-6097.000000	
26	Tripura			143.000000	138.980000
27	NEEPCO (Kopili-I)		-349.780000	-340.000000	
28	NEEPCO (AGBPP)		-9703.43	-9430.470000	

ENERGY EXCHANGE( in MU ) IN NER DURING January, 2012

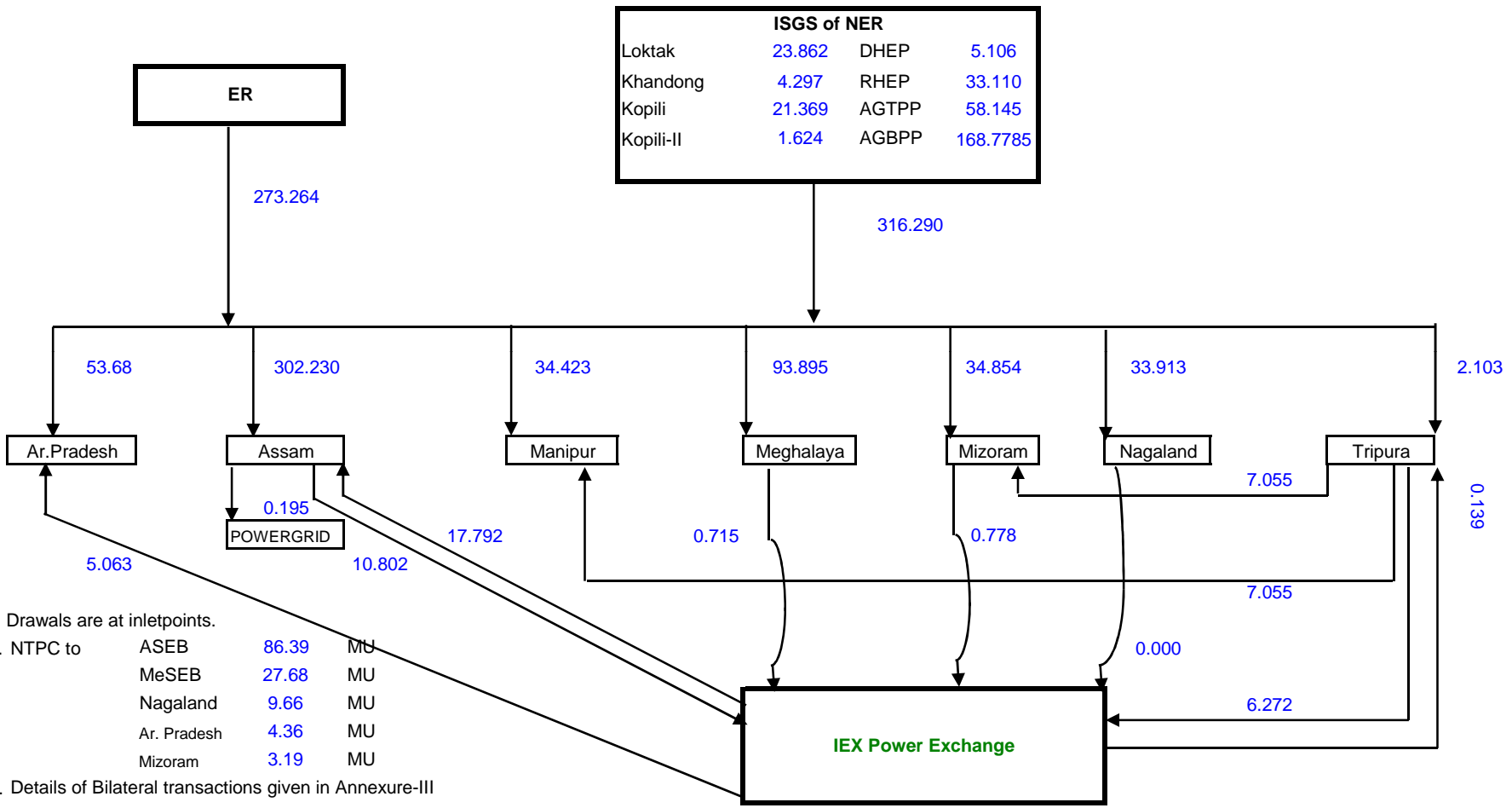

N.B - 1. Drawals are at inletpoints.  
 2. NTPC to ASEB 86.39 MU  
 MeSEB 27.68 MU  
 Nagaland 9.66 MU  
 Ar. Pradesh 4.36 MU  
 Mizoram 3.19 MU  
 3. Details of Bilateral transactions given in Annexure-III

### Frequency Duration for January, 2012

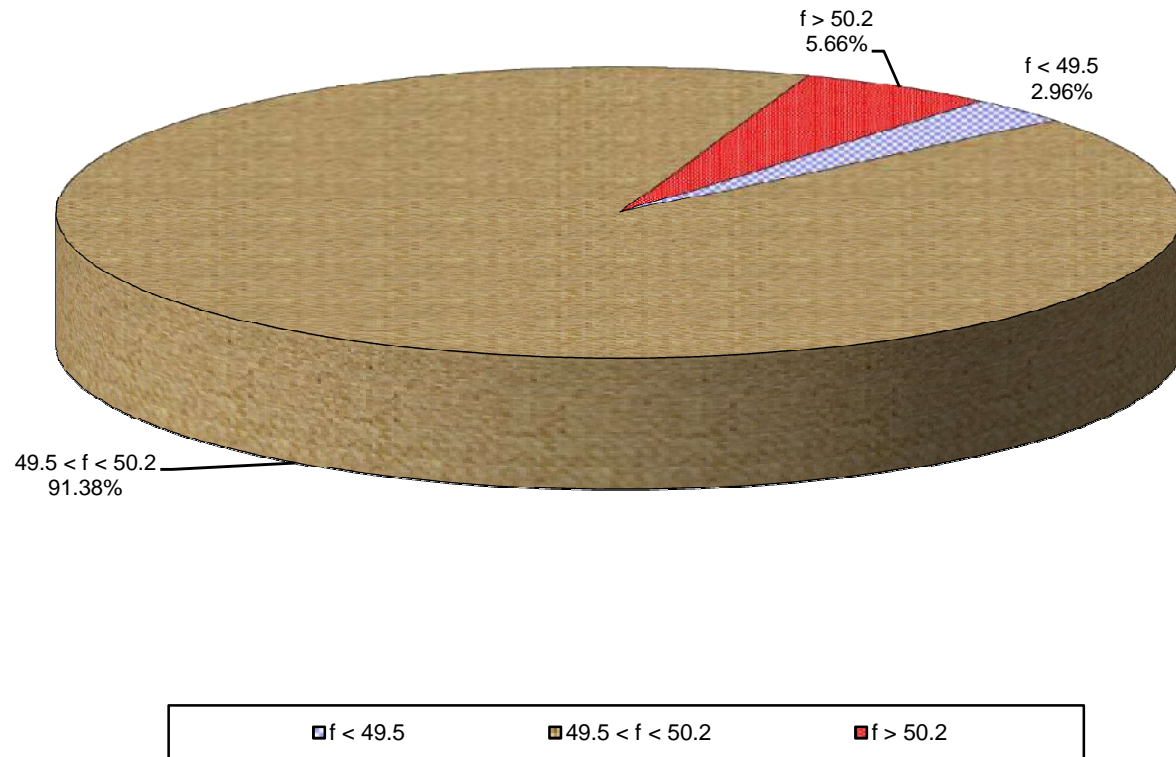

FVI Characteristics for January, 2012

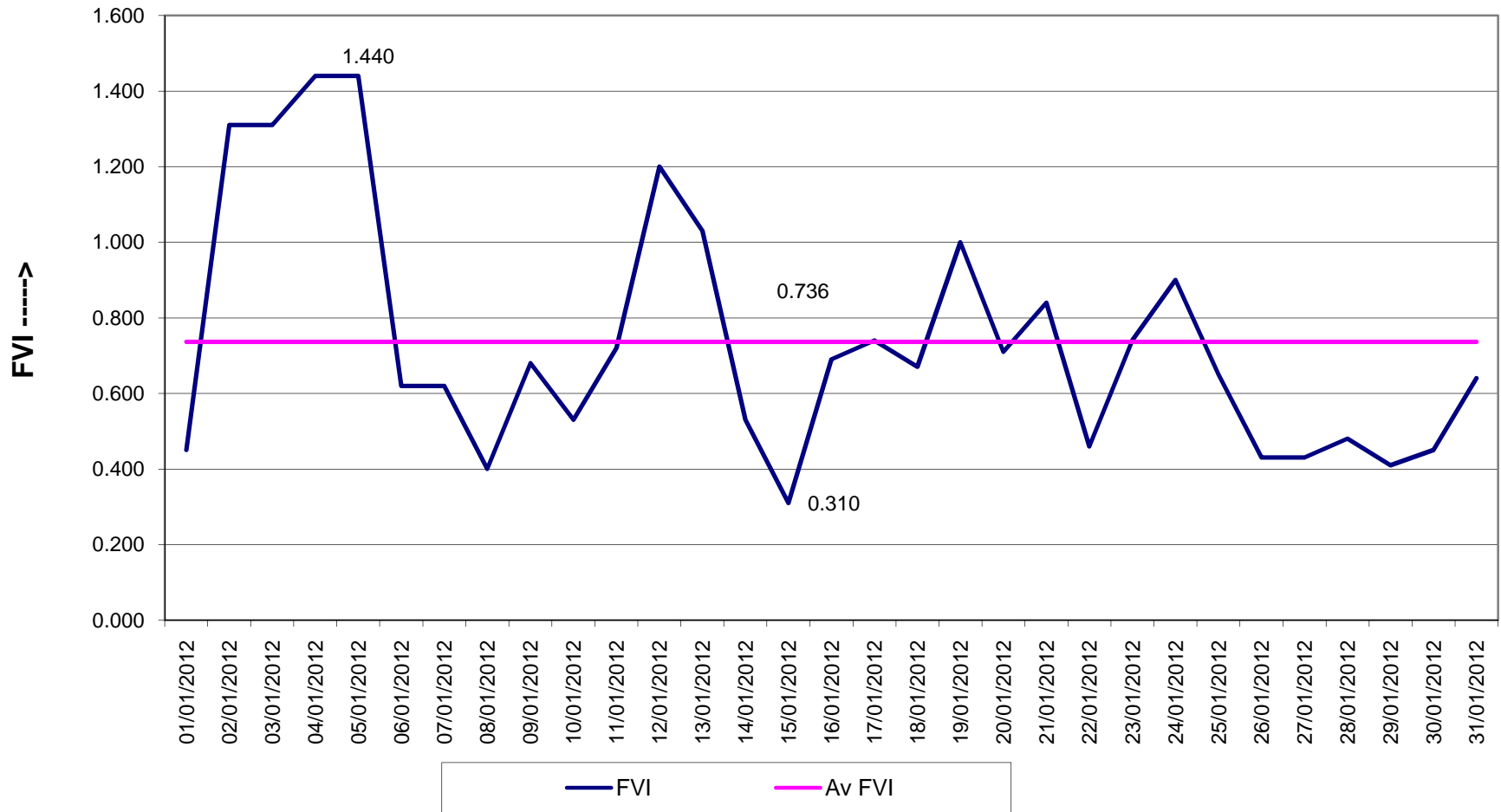

Maximum & Minimum Voltage Levels of Important Substations in NER during

January, 2012

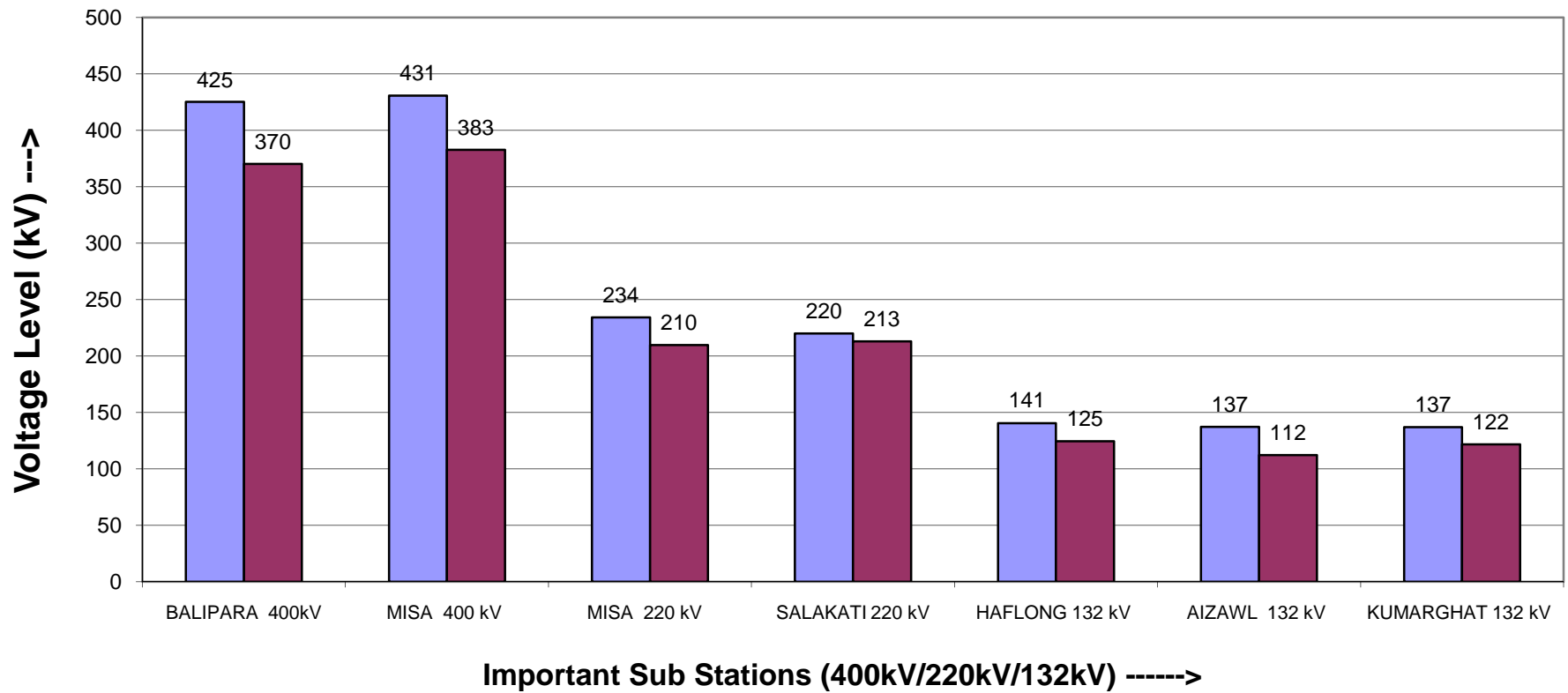

State and Central Sector Generation (MU) in NER in January, 2012

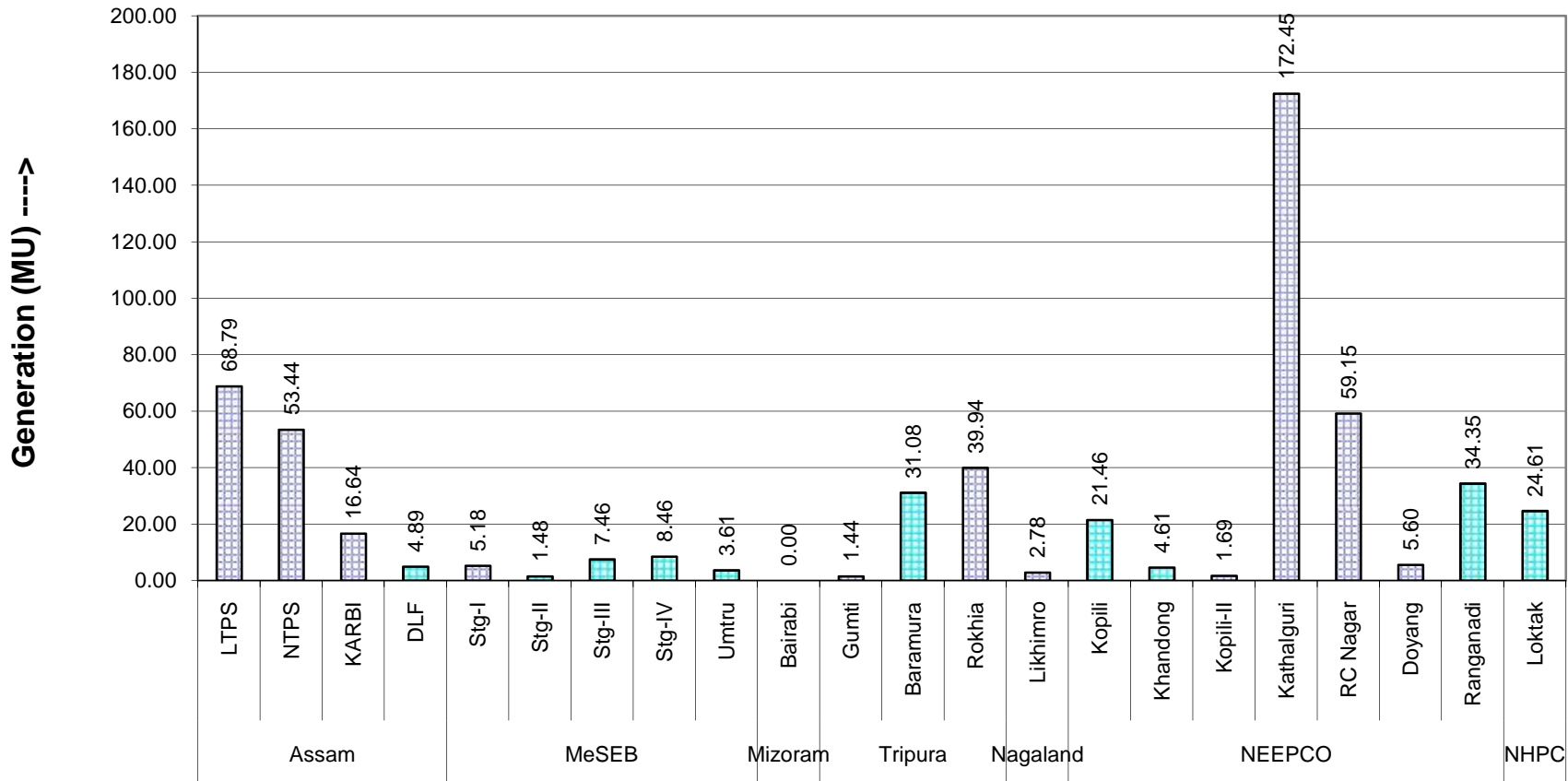

NER States Energy Scenario in January, 2012

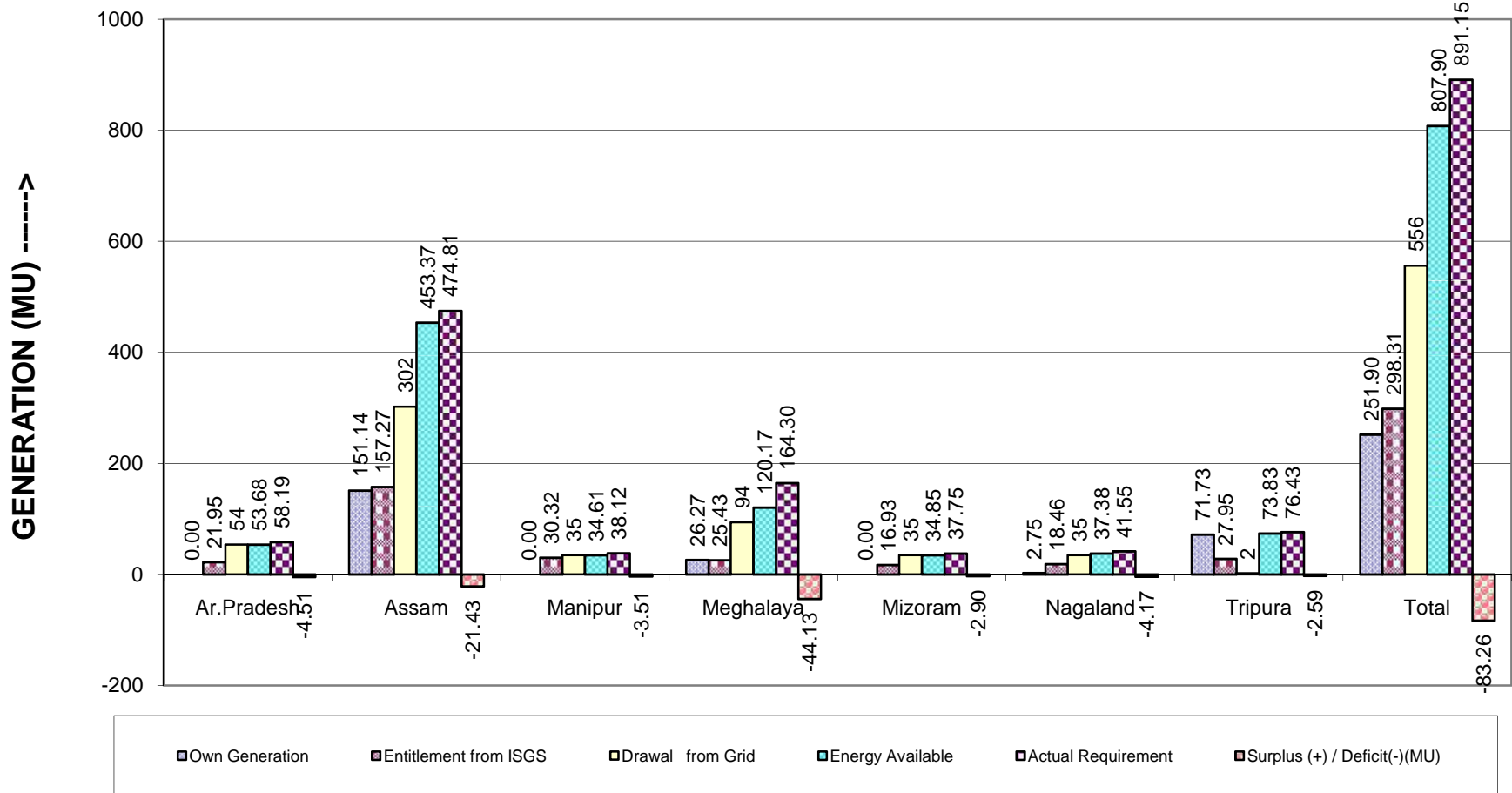

Reservoir Statistics of NER in January, 2012

