

North Eastern Regional Power Committee

Agenda For

154th OCC Sub-Committee Meeting

Time of meeting : 15:00 Hrs.

Date of meeting : 13th March, 2019 (Wednesday)

Venue : "Hotel Nandan", Guwahati.

A. CONFIRMATION OF MINUTES

CONFIRMATION OF MINUTES OF 153rd MEETING OF OPERATION SUB-COMMITTEE OF NERPC.

The minutes of 153rd meeting of Operation Sub-committee held on 14th February, 2019 at Guwahati were circulated vide letter No. NERPC/SE (O)/OCC/2016/4556-4591 dated 28th February, 2019.

The Sub-committee may confirm the minutes of 153rd OCCM of NERPC with the following amendments as no other comments/observations were received from the constituents.

ACTION TAKEN -ITEMS

B.1. ACTION TAKEN:

1. IMPLEMENTATION OF PROJECTS FUNDED FROM PSDF:

The status as informed in 153rd OCC:

State	R&U scheme	ADMS	Capacitor Installation	SAMAST **	Line Differential Protection
Ar. Pradesh	Pkg-I: OBD completed. By Feb'19 LOA. Pkg-II: Tendering in process.	To submit comments to NIT by 18/02.	-	TESG queries submitted.	-
Nagaland	Pack-B: Dec'18 Pack-C: Dec'18	To submit comments to NIT by 18/02.	To re-submit proposal to NERPC for Study.	TESG queries to be submitted.	Lines identified. Under DPR preparation stage.
Mizoram	LOAs issued. Completion by Mar'19.	To submit comments to NIT by 18/02.	To re-submit proposal to NERPC for Study.	TESG queries submitted.	Lines not yet identified. To be taken up in Sub-group.
Manipur	LOAs issued. Completion by Nov'18.	To submit comments to NIT by 18/02.	Submitted to NERPC for Study before sending to	TESG queries to be submitted.	Lines not yet identified. To be taken up

Agenda for 154th OCC Meeting to be held on 13th March, 2019

			NPC/NLDC.		in Sub-group.
Tripura	90% completed. Remaining by Feb'19	To submit comments to NIT by 18/02.	To submit proposal to NERPC for Study.	TESG queries submitted.	Lines not yet identified. To be taken up in Sub-group.
Assam	Substation auxiliary and diagnostics tools - Tendering in process. LOA by Dec'18.	To submit comments to NIT by 18/02.	-	TESG queries submitted.	Lines identified. Under DPR preparation stage.
Meghalaya	MePTCL LOA issued, 95% completed. Remaining LOAs by Feb'19. Commissioning works 60% completed, Total balance works by Jun'19. MePGCL - Erection complete by Mar'19	Revised DPR submitted. Query referred to DISCOM	-	TESG queries submitted.	DPR already submitted and awaited approval.

The entities may also be advised to furnish status as per format by first week of every month on regular basis to Member Convener, PSDF Project Monitoring Group (AGM, NLDC, POSOCO) with a copy to NPC & NERPC. The LOAs of R&M Scheme are to be furnished to NERLDC/NERPC regularly.

States may please intimate the latest status.

2. Long Outage of Important Grid Elements:

Name of the Element	Name of Utility	Status as informed in 153 rd OCC	Latest status
63MVAR Reactor at Byrnihat to replace with 80MVAR Reactor	MePTCL	To be updated in MoM. PGCIL agreed to share the sample bid document to MePTCL within March 2019.	
Outage of 420kV 80MVAR L/R for 400kV Bongaigaon-NSLG-I at Bongaigaon - (out since 04.07.18)	NERTS	By February, 2019	
132kV Dimapur - Imphal (out since 25.07.18)	NERTS	By March, 2019	
220kV Sonabil-Samaguri-I	AEGCL	Tender by March, 2019	
420kV 63 MVAR Line Reactor at 400 kV Bongaigaon S/S for 400kV Bongaigaon-Azara(out since Nov'18)	NERTS	After 9th March'19 due to outage of ICT # 1 at Misa and 220kV Bus # 1 & 2 at Kopili	

Utilities may please intimate the latest status.

3. DIFFERENCE IN ACTUALS VS LGBR:

Energy Requirement:

Name of State	Sep 18 (actual)	Sep 18 (LGBR)	Oct 18 (actual)	Oct 18 (LGBR)	Nov 18 (actual)	Nov 18 (LGBR)	Dec 18 (actual)	Dec18 (LGBR)
Ar. Pradesh	74.16	71.19	70.06	77.25	67.34	77.97	75.90	72.19
Assam	950.19	934.64	815.67	885.83	707.55	707.17	691.41	719.43
Manipur	69.88	69.64	75.80	75.56	81.80	78.59	89.09	87.43
Meghalaya	150.14	164.00	144.61	166.00	163.83	169.00	192.05	175.00
Mizoram	58.04	39.37	70.64	44.19	67.71	47.06	53.75	56.60
Nagaland	80.49	76.88	74.27	69.66	61.04	64.67	79.63	80.10
Tripura	192.00	125.18	187.38	132.09	164.71	98.49	165.65	96.16

Energy Availability:

Name of State	Sep 18 (actual)	Sep 18 (LGBR)	Oct 18 (actual)	Oct 18 (LGBR)	Nov 18 (actual)	Nov 18 (LGBR)	Dec 18 (actual)	Dec18 (LGBR)
Ar. Pradesh	81.12	82.62	67.90	77.45	64.46	63.39	61.98	57.96
Assam	987.64	859.96	772.79	898.78	747.84	795.50	748.10	765.58
Manipur	177.79	110.48	105.39	117.42	85.54	106.01	101.86	87.00

Agenda for 154th OCC Meeting to be held on 13th March, 2019

Meghalaya	276.17	308.96	200.13	274.43	175.54	206.71	206.14	194.14
Mizoram	111.76	89.77	106.29	83.22	89.63	69.34	67.34	58.83
Nagaland	81.24	87.96	68.17	88.06	53.51	72.04	63.19	65.59
Tripura	309.44	268.15	342.04	300.01	332.36	272.69	336.56	280.83

Demand:

Name of State	Sep 18 (actual)	Sep 18 (LGBR)	Oct 18 (actual)	Oct 18 (LGBR)	Nov 18 (actual)	Nov 18 (LGBR)	Dec 18 (actual)	Dec18 (LGBR)
Ar. Pradesh	131.92	143	129.08	146.00	127.77	145.00	132.80	140.00
Assam	1865.26	1787.60	1785.42	1840.56	1546.54	1558.56	1440.10	1506.61
Manipur	184.39	168.04	187.28	175.61	189.23	182.53	213.75	196.00
Meghalaya	317.42	328.18	336.23	320.58	352.42	342.37	365.46	405.90
Mizoram	95.47	95.23	99.18	96.76	102.12	104.38	111.57	114.40
Nagaland	142.07	148.77	133.77	138.05	139.00	133.50	135.04	156.55
Tripura	296.01	359.46	269.32	312.39	258.54	278.62	239.53	225.23

B.2. OPERATIONAL PERFORMANCE AND GRID DISCIPLINE DURING FEBRUARY, 2019

As per the data made available by NERLDC, the grid performance parameters for February, 2019 are given below:

NER PERFORMANCE DURING FEBRUARY, 2019

States	Energy Met (MU)		w.r.t. Jan,19 % inc (+) /dec (-)	Energy Reqr. (MU)		w.r.t. Jan,19 % inc (+) /dec (-)	% inc (+) /dec (-) of energy reqr vs met. In Feb,19
	Feb-19	Jan-19		Feb-19	Jan-19		
Ar. Pradesh	76.93	68.24	12.73	77.28	68.59	12.67	-0.45
Assam	621.73	711.61	-12.63	635.00	720.73	-11.89	-2.09
Manipur	94.74	85.75	10.48	95.46	86.24	10.69	-0.75
Meghalaya	188.34	198.64	-5.19	188.35	198.64	-5.18	-0.01
Mizoram	70.46	54.55	29.17	70.98	55.05	28.94	-0.73
Nagaland	77.40	64.14	20.67	85.74	72.48	18.29	-9.73
Tripura	147.46	115.91	27.22	148.35	116.00	27.89	-0.60
Region	1277.05	1298.85	-1.68	1301.15	1317.74	-1.26	-1.85

States	Demand Met (MW)		w.r.t. Jan,19 % inc (+) /dec (-)	Demand in (MW)		w.r.t. Jan,19 % inc (+) /dec (-)	% inc (+) /dec (-) of energy reqr vs met. In Feb,19
	Feb-19	Jan-19		Feb-19	Jan-19		
Ar. Pradesh	148	124	19.35	138	138	0.00	-6.76
Assam	1440	1468	-1.91	1417	1491	-4.96	-1.60
Manipur	194	216	-10.19	192	219	-12.33	-1.03
Meghalaya	356	372	-4.30	355	372	-4.57	-0.28
Mizoram	109	119	-8.40	102	121	-15.70	-6.42
Nagaland	132	138	-4.35	130	140	-7.14	-1.52
Tripura	231	223	3.59	231	224	3.13	0.00
Region	2514	2552	-1.49	2480	2575	-3.69	-1.35

REGIONAL GENERATION & INTER-REGIONAL EXCHANGE IN MU

AVERAGE FREQUENCY (Hz)

Month---->	Feb-19	Jan-19	Month---->	Feb-19	Jan-19
Total Generation in NER (Gross)	1101.311	1337.745		% of Time	% of Time
Total Central Sector Generation (Gross)	841.084	1048.299	Below 49.9 Hz	7.23	10.69
Total State Sector Generation (Gross)	260.227	289.446	Between 49.9 to 50.05 Hz	70.92	70.25
Inter-Regional Energy Exchange			Above 50.05 Hz	21.85	19.06
(a) NER-ER	184.75	372.13	Average	50.00	49.99
(b) ER-NER	1.07	1.15	Maximum	50.26	50.28
(c)NER-NR	4163.00	0.00	Minimum	49.68	49.58
(d)NR-NER	45.83	433.45			
© Net Import	-4300.85	62.47			

C. ITEMS- STATUS REVIEW

1. Status of Generating Units, Transmission Lines in NER:

During 153rd OCC meeting, the status as informed by different beneficiaries is as follows:

SN	Items	Status as given in 153 rd OCC Meeting		Status as given in 154 th OCC Meeting	
		Timeline for completion	Furnishing of detail parameters	Timeline for completion	Furnishing of detail parameters
a. New Elements					
	250 MW BgTPP Unit#III				
1	400/220kV, 315 MVA ICT-1 of NTPC at Bongaigaon	By Mar'19	To be submitted to NERLDC.		
2	Kameng HEP of NEEPCO two units (2 x 150 MW) Next two units (2x150 MW)	By Mar'19	Already submitted.		
3	132kV Monarchak – Surjamaninagar D/C of TSECL	by Jun'19	To be submitted to NERLDC.		

Agenda for 154th OCC Meeting to be held on 13th March, 2019

4	400/220 kV 315 MVA ICT-II at Bongaigaon	LV side (GIS) is expected to be completed by Mar'19.	LV side separate application to be submitted		
5	220/132 kV, 160MVA ICT-II at Balipara	Not allowed for transit by WB Govt. to factory. Uncertain date.	To be submitted to NERLDC.		
6	220/132 kV, 1x160 MVA ICT with GIS Bay at Kopili	Expected to be completed by Mar'19	To be submitted to NERLDC.		
7	33kV bay at 220kV Mariani(AS) S/Sn	Payment done. APDCL to expedite.	Not applicable.		
8	33kV bay for 132kV Badarpur(PG) S/Sn	To be expedited by APDCL.	Not applicable.		
9	Dedicated 33kV feeder at Khliehriat Substation from Lumshnong.	To be taken up with MePDCL. SLDC to kindly mediate.	Not applicable.		
10	Replacement of 2x315 MVA ICTs with 2x500 MVA ICTs at Misa (PG)	<ul style="list-style-type: none"> • ICT-I Expected by March'19 without Tertiary connectivity of 4X25MVAR Tertiary Reactors and • ICT-II Expected by Jun'19 	To be submitted to NERLDC.		
	220kV Balipara- Sonabil-II				
b. Elements under breakdown/upgradation					
11	Up-gradation of 132 kV Lumshnong-Panchgram line	DPR sent to NLDC/NPC	Not applicable.		
12	Switchable line Reactors at 400 kV Balipara & Bongaigoan Ckt # 1 & 2	Completed in all aspects	Not applicable		

Agenda for 154th OCC Meeting to be held on 13th March, 2019

13	PLCC Panels at Loktak end of Loktak – Ningthoukhong 132 kV feeder and Loktak - Rengpang 132 kV feeder	Panels not supplied at Loktak end. NERPC to write to MD, MSPCL to expedite.	Not applicable.		
14	Replacement of CTs and installation of Bus Bar Protection at 220 kV Misa	Expected Completion : Mar'19	Not applicable		
15	Upgradation of 132 kV Bus Bar at Umiam Stg-III to ACSR Zebra	DPR will be submitted soon.	Not applicable		
16	220/132 kV 30 MVA ICT at Mokokchung	Mar'19(LOA date) to be reviewed later on.	To be submitted to NERLDC		

400kV Transfer Bus at BgTTP first time charged at 11:35hrs of 01.03.2019.

Concerned constituents may kindly intimate the status.

C.2. Update on Real Time Energy Assessment for Effective Grid Management:

In 153rd OCC meeting, it was decided that a Special Meeting would be convened to resolve the issues pertaining to REAL/TARA, SCADA & Communication.

NERPC/CDAC may please update the status.

C.3. Ensuring proper functioning of Under Frequency Relays(UFR) & df/dt Relays:

In 7th NPC meeting held on 08.09.17 it was agreed that mock test is good enough to test the healthiness of the UFR & df/dt relays. The frequency of site inspection was proposed to be upto six months. RPC may carry out periodic inspection, in line with provisions of IEGC and furnish inspection reports to NPC.

Discussions as per previous meetings:-

- Inspection for Mawphlang completed.
- Inspection for Baghjap, Sankardevnagar and Sipajhar under Assam would be tentatively done by 1st week of Mar'19.

NERPC may please intimate the latest status.

C.4. Extended C Band VSAT for power system communications in NER:

As per discussion in previous meetings:

- Leased Line Connectivity has been explored by NERTS for Roing, Tezu & Namsai with recurring expenditure amounting to INR 28 lakhs.

Agenda for 154th OCC Meeting to be held on 13th March, 2019

- VSAT Pilot project to be executed at Byrnihat station. The data would be transmitted from Byrnihat to KPTCL (via satellite) to SRLDC to NLDC to NERLDC. This would be kept in monitoring mode in the interim. Pilot project cost breakup is to be put up for approval in the next TCC/RPC meeting. NERLDC has requested for finalisation of modality for VSAT pilot project. Quotation enclosed as Annexure-21
- NERPC to take up with proper authorities for funding of VSAT in NER from suitable sources.
- Financial impact for NER states i.r.o. VSAT for Roing, Tezu, Namsai by POWERGRID is to be explored (tentative cost is ₹ 54,653,880.00 for 5 years).- matter has been referred to Corporate LD&C.
- Technical visit on 10.12.2018 concluded that VSAT for NER is technically feasible.

NERPC/NERLDC may please intimate the status.

C.5. DIMAPUR_PG Voice communication and telemetry out since Feb'18.

In 152nd OCCM NERTS informed that Dimapur communication would be restored by Mar'19.

NERTS may please intimate the status.

C.6 Update on PDMS:

As per deliberation in the previous meeting(s) the following status/decisions:-

- Operational load flow has been completed and circulated to all constituents for comments. *SLDCs may please update the status.*
- Database building and network modelling for Assam has been completed.
- Server installation at NERPC to commence in March'19.

NERPC/PRDC may please update the status.

C.7. Submission of the Annual Load Generation Balance Report (LGBR) for Peak as well as Off-peak scenarios and the Annual outage plan for 2019-20 by 31.12.18 as per IEGC

As per IEGC, each SLDC shall submit LGBR for its control area, for peak as well as off-peak scenario, by 31st December for the next financial year, to respective RPC Secretariat. The annual plans for managing deficits/surpluses in respective control areas shall clearly be indicated in the LGBR submitted by SLDCs.

As per IEGC, all SEBs/STUs, Transmission Licensees, CTU, ISGS, IPPs, MPPs and other generating stations shall provide to the respective RPC Secretariat their proposed outage plan in writing for the next financial year by 31st October of each year. These shall contain identification of each generating unit/transmission line/ICT etc., the preferred date for each outage and its duration and where there is flexibility, the earliest start date and latest finishing date.

In 153rd OCC, Director, NERPC stated that the LGBR for 19-20 would be completed by 28.02.19.

NERPC may please update the status.

C.8 Non-availability/ Non-functioning of synchronization facility at numerous stations

As per deliberations in the previous the following is the status for synchronization facility at stations of different utilities:-

- NERTS – All stations synchronization facility available. The same is available at RTAMC. Sync check to be tested for 132kV AGTCCPP-Kumarghat on 16.02.19- ***NERTS/NERLDC may please update the status.***
- AEGCL – Sync check not available for 132kV stations. Procurement of synchronizing trolley and associated equipments(sockets etc.) to be completed by July'19. ***AEGCL may please update status.***
- DoP Ar.Pradesh – Sync check not available at Lekhi and Chimpu. Would be in place by Sep'19. ***DoP Ar.Pradesh may please update the status.***

Members may please discuss.

C.9 Compliance of CERC Order:

Against compliance of CERC Order dated 14.06.2016(Non-compliance of Commission's direction dated 26.9.2012 in Petition No. 168/MP/2011) in Petition No.09 & 10/SM/2014 Commission directed RPCs Secretariat to examine the cases of delayed clearance of faults on the transmission system during last two years in respective Region and submit an analysis report within six month from the date of issue of order. The 154th OCC forum requested NERLDC to compile the cases of delayed clearance of faults on the transmission system for 2016-17 and 2017-18. NERLDC agreed and promised that the report would be compiled latest within two months.

NERLDC may please update the status.

C.10 Phase shift errors in PMU:

In 154th OCCM Sr.GM, NERTS informed that the 220kV of NER has phase matching with 220kV ER(Birpara). So, at present it is not recommended to change at primary as downstream will be affected. After detailed deliberations, the forum decided that wirings in the secondary may be changed. In this regard, a matrix is to be made for changing the connections. Since PMU is not installed in all ISTS elements, concerned utilities are requested to trigger DR output manually for all ISTS elements and submitted to NERPC/NERLDC for preparation of the matrix. It was decided that a team from NERPC (Sh Srijit Mukherjee), NERTS (Sh. Supriya Paul/Devaprasad Paul), NERLDC (Sh. Zerin Jacob) & AEGCL (Sh. Abhishek Kalita) will identify the exact problem at Silchar, Misa & Sarusajai by Feb'19.

NERPC may please update the status.

C.11 Compensation for Heat Rate degradation and Auxiliary Energy Consumption in case of gas based power plants:

In 154th OCCM it was decided that a Special Meeting would be convened prior to the 154th OCC to discuss the Heat Rate Degradation and Compensation Calculation for Thermal Power Plants.

NERPC may please intimate the status.

C.12 Design & implementation of SPS for Outage of 400 kV Bus

400 kV Bus — I & II at Silchar (PG) and Outage of any one circuit of 400 kV Bongaigaon — BgTPP D/C

In 153rd OCCM, CGM, NERLDC clarified that upon System Study by NERLDC the above SPS has been proposed. After detailed deliberation, it was decided that the matter would be discussed in System Study Meeting separately. NERPC informed that System Study Meeting would be scheduled in the 1st week of Mar'19.

NERPC may please intimate the status.

C.13 Schedule for special meeting on review of existing SPSs & devising new SPSs as per present requirement of NER grid

In 153rd OCCM it was decided that the matter would be discussed in System Study Meeting separately.

NERPC may please intimate the status.

C.14 Operation of RHEP units in Synchronous condenser mode

In 153rd OCCM, Sr. Manager, NEEPCO informed that prima-facie it appears that Synchronous Condenser mode operation is not possible. However NEEPCO has written to BHEL(Bhopal) for solution. This item would be reviewed in the next meeting.

Details enclosed as Annexure-2.4

NEEPCO may please intimate the status.

C.15 Providing High speed, reliable internet connection by all ISGS & SLDCs

In 153rd OCCM, CGM, NERLDC stated that in light of the commissioning of WBES it has become very essential for all the ISGSs and SLDCs to have high speed internet connection. The forum noted that the matter has already been taken up in the 19th NERPC meeting for urgent action. The members requested NERLDC to explore the following:

- a. A Lite version of WBES website with less features. This will enable punching requisition/DC even over 2G/EDGE network,
- b. USSD based application for transmission of schedule related information in real time. NERLDC agreed to the same.

All SLDCs/NERLDC may please update the status.

C.16 Accurate Load forecasting by SLDCs as per IEGC c1.5.3 for better system operation

In 153rd OCCM NERLDC presented the RMSE for the month of Dec'18:

% Error with Actual Data (Forecasted by States)							
	Ar Pradesh	Assam	Manipur	Meghalaya	Mizoram	Nagaland	Tripura
Median	16	6	7	10	32	12	8

Mizoram & Arunachal Pradesh SLDCs are requested to check the methodology for improving the load forecast.

SLDC Mizoram/ SLDC Ar.Pradesh may please update the status.

C.17 Construction of Bay for 132kV Agia-Nongalbibra Line at 220kV Agia Sub Station, Agia, Assam

Stringing of 2nd Circuit 132kV Nongalbibra -Agia Line (SPA Scheme) Rs. 1.11 Cr Deposited by MePTCL by SBI Chq No. 511140 Dt. 15.03.2016 for the above work. Stringing of the Line Completed in 2018.

MePTCL requested AEGCL to kindly intimate the latest status at the earliest.

AEGCL/MePTCL may please update the status.

C.18 Inclusion of OPGW in scope of Reconductoring of lines with OPGW:

In 153rd OCCM, EE, System Protection, MePTCL, informed the Chair on the observations of TEGS on the DPR's for re conductoring of lines with HTLS submitted by MePTCL wherein the observations desires that the OPGW component be excluded from the scope of works in DPR's. He requested the Chair to take up with the matter with NLDC for consideration of the OPGW item in DPR.

NERPC may please intimate the status.

C. 19 Tentative schedule for Black Start & Restoration Procedure Mock exercise in NER during the year 2019

The 153rd OCC forum requested NERLDC to prepare and circulate the tentative schedule for Black Start & Restoration Procedure Mock exercise. The tentative schedule is as follows:

AGTCCPP	March 2019
Loktak	April 2019
Khandong & Kopili st II	May 2019
Kopili	June 2019
AGBPP	July 2019
Ranganadi	August 2019
Pare	September 2019
Doyang	October 2019

Respective ISGSs are requested to finalize the dates for the mock exercise as per the tentative schedule.

The draft Procedure for Mock Black Start for AGTCCPP was shared via email dated 06.03.2019 by NERLDC. Details enclosed as Annexure-15

Tentative schedule for BSRP workshop in NER- 27 March 2019

Tentative procedure for mock black start exercise for AGTCCPP and synchronising facility testing at Kumarghat Substation (PG). Email copy and Tentative Procedure enclosed in Annexure -19

NEEPCO/NHPC may please intimate the status.

AGENDA ITEMS FROM NERLDC:

C. 20 DVAR and PSS at AGTCCPP:

Expected date of commissioning of DVAR and PSS at AGTCCPP. Letter No NERLDC/SO-II/2798 dated 22.02.19 regarding low frequency oscillations observed at Agartala PMU is enclosed as Annexure C.20.a. Oscillation observed in AGTCCPP Bus

Agenda for 154th OCC Meeting to be held on 13th March, 2019 during low loading and synchronization of Unit 1 (Details are enclosed as Annexure-C.20.b.

NERLDC may please deliberate.

C. 21 Metering Status Review:

- a. Installation of TARA devises in all the States- Status
- b. Installation / Replacement of SEMs by NERTS - Action
- c. Tendering of S/W for the additional Laptops (70 Nos)
- d. Procurement & Disbursement of DCDs by NERTS (distribution list enclosed as **Annexure-C.21.d**)
- e. Spare SEM / DCDs, Status & procurement

NERLDC may please deliberate.

D. I T E M S FOR DISCUSSION

D.1 Generation Planning (ongoing and planned outages)

- a. Present per day MU and projected number of days of operation.

Plants	Reservoirs level in meter	MU content	Present DC (in MU)	No of days as per current generation
Khandong + Kopili stg II			0.198	
Kopili			1.104	
Doyang			0.15275	
Loktak			1.097	

The outage of other generating stations may be approved considering the present water levels in reservoirs.

The Committee may discuss and approve the proposed shutdown by Generating Stations as given in Annexure - D.2 which is available in NERPC website.

D.2 Outage Planning Transmission elements

It was agreed in the 99th OCC meeting that shutdown will be availed only after approval is given by the OCC forum. It was also agreed that deferment/revision of outages elements other than already approved in OCC will be henceforth put/displayed in the website of NERPC (**under Operational Activities/OCC Approved shutdown**) as per CERC regulations/ CEA guidelines etc for ensuring smooth & secure grid operation.

Furnishing request of shut down of the element, which was approved by NERPC, by Indenting Agency (ISTS licensees/STUs/Generating Companies) to NERLDC:

Planned shutdown approved by NERPC shall be considered for implementation by NERLDC on D-3 basis. If an outage is to be availed on say 10th of the month, the shutdown availing agency would reconfirm to NERLDC on 7th of the month by 10:00 Hr. This practice is necessary to ensure optimal capacity utilization and the time required for associated system study/coordination by/amongst RLDC/NLDC.

The sub-Committee may kindly discuss and approve the transmission line outages proposed by Constituents for March,2019 - April,2019 which is available in the website of NERPC.

D.3 Estimated Transmission Availability Certificate (TAC) for the month of November, 2018 - January, 2019:

NETC and POWERGRID have submitted the outage data for the month of November, 2018 - January, 2019. So the attributability of outage of the said elements may please be finalized.

Members may please discuss.

D.4 Joint validation of SCADA data by NERTS & NERLDC

In 153rd OCCM, CGM, NERLDC informed that the data validation has been partially completed. He requested active participation from NERTS so that the same may be completed by Feb'19.

The latest status as intimated by NERLDC: 16 out of 23 stations completed. Details enclosed as **Annexure-D.4**

Members may please discuss.

D.5 RGMO performance analysis of instances during January 2019

NERLDC presented a report on RGMO performance for an event on 05th Feb 2019 at 11:57 Hrs when load loss of approx. 869 MW occurred in Northern Region wherein the following generators have not given the desired response:

-Palatana GTG-I -BgTPP Unit – II

And the following generators have given negative response:

-Palatana GTG-II, STG-I/II -Kopili Unit#I

-BgTPP Unit #I

The 153rd OCC forum requested OTPC, NEEPCO and NTPC to analyse the same and revert back. NERLDC requested all ISGS to share unit wise GDAM/ DAS Data for all such events whenever intimation of such events is given by NERLDC via email. If DAS data not submitted by Generators, SCADA data shall be considered for calculation of RGMO response.

OTPC/NEEPCO/NTPC may please intimate the status.

D.6 Assessment of TTC, TRM & ATC by SLDC on respective Inter-State Transmission Corridor

The 153rd OCC forum requested all the SLDCs to carry out the TTC/ATC calculations and decided that SLDC Ar. Pradesh would give presentation in the next OCC.

Members may please discuss.

D.7 Reliable power supply to Manipur system

For Ensuring reliable power supply to Manipur system, following actions were suggested by NERLDC:

- a. 132 kV Jiribam – Jiribam (MA) – Rengpang – Loktak link to be kept in loop
- b. Restoration of 132 kV Dimapur – Imphal line
- c. Upgradation of 132 kV Kohima – Karong – Imphal (MSPCL) link

Members may please discuss.

AGENDA ITEMS FROM NERLDC:

D. 8 Scheduling of unscheduled surplus power from ISGS:

CERC Order Dated 17 October 2017 regarding scheduling of unscheduled surplus power from the Inter-State Generating Stations, URS protocol in NERLDC is prepared in compliance of the order. The detailed protocol is attached as Annexure-D.8(1) and Annexure-D.8(2)

NERLDC may please deliberate.

D. 9 Instances of non-compliance/violation of IEGC:

Instances of non-compliance of IEGC affecting grid security

- a. Under drawl of States and ISGS during High Frequency (Details are enclosed as **Annexure-D.9.a**)
- b. Non availing of OCC approved shutdown on D-3 basis
- c. AGBPP schedule and actual generation mismatch.

Multiple Emergency Shutdowns of Palatana (Details enclosed as **Annexure D.9B**)

Lack of information w.r.t tripping of 132kV Kopili-Khandong-II on 06.03.2019 (Details enclosed as **Annexure D.9C**)

NERLDC may please deliberate.

D. 10 Overloading of 132kV Pare-Lekhi line:

To limit the overloading of 132kV Pare-Lekhi line, 132kV Itanagar-Lekhi line has to be kept closed. As reported by SLDC Arunachal Pradesh during real time, they are unable to close the 132kV Itanagar-Lekhi line. Status review of CT ratio of 132kV Itanagar-Lekhi (Study results enclosed as Annexure-D.10)

NERLDC may please deliberate.

D. 11 Bus Configuration issues for various sub-stations:

Distribution of 132 kV lines in both 132 kV Bus-1 & Bus-2 at Surajmaninagar for reliable operation. Action is to be taken by TSECL.

400kV Bus-A at Ranganadi & 132 kV Transfer Bus at Loktak are not commissioned as per the scheme since inception.

NERLDC may please deliberate.

D. 12 High voltage in various 400kV nodes:

High voltage of observed in 400 kV nodes of NER grid (Balipara, BNC & RHEP) for 18 minutes w.e.f 23:55 Hrs on 22.02.19 while increasing power order of HVDC BNC –

Agenda for 154th OCC Meeting to be held on 13th March, 2019

Agra from 500MW to 700MW after de-blocking of Pole-1. Voltage plots of SCADA data for this period is enclosed as Annexure 10. 400 kV Biswanath Charali - Balipara tripped at 00:07 Hrs on 23.02.19 on Over Voltage in Y-ph at BNC.

High voltage was observed in major 400 kV nodes (phase voltage of 295 kV at Balipara, 303 kV at BNC & 299 kV at RHEP) while tripping of HVDC BNC-APD-Agra pole-1 on 29th Aug'18.-Action plan from NERTS requested with root cause analysis of event on 22.02.19 to avert future incidents

NERLDC may please deliberate.

D. 13 Reactive power capability/injection of generating stations:

1. Tentative schedule for Reactive Power Capability testing of generating units- Tentative date for testing at Pare is 05.04.2019
2. Palatana units are not capable of regulating MVAR absorption/injection as the units are in AVR mode. Manual VAR regulation is not possible as informed by Palatana.

NERLDC may please deliberate.

D. 14 Multiple tripping of 132kV Imphal-Imphal-I:

Multiple tripping of 132kV Imphal-Imphal-I due to downstream fault. Details of tripping are enclosed as **Annexure-D.14.a**

Letter No NERLDC/SO-II/NERTS/2019/2539, Letter No NERLDC/SO-II/NERTS/2019/2818 is enclosed as **Annexure-D.14.b** and **Annexure-D.14.c**-. Action plan from MSPCL requested with root cause analysis to avert future incidents

NERLDC may please deliberate.

D. 15 Improvement of SCADA data availability:

Improvement of SCADA data availability to NERLDC. State wise Comparison of % data availability enclosed as Annexure-D.15, Annexure-D.15.a, Annexure-D.15.b

NERLDC may please deliberate.

D. 16 Non-availability of relay details at RTAMC:

Full relay details from site is not accessible from RTAMC due to which collection of Relay details after any line tripping are getting delayed for the remotely controlled substation of Powergrid(Details enclosed as Annexure-D.16).

NERLDC may please deliberate.

D. 17 Primary response testing of generators:

Submission of data w.r.t primary response testing of generators as per format circulated by NLDC from NHPC, NTPC, NEEPCO.

NERLDC may please deliberate.

D. 18 Operating procedure:

Draft Operating Procedure for the year 2019 is mailed to all Utilities. It is requested to give comments by 30th April'19

NERLDC may please deliberate.

D. 19 Nodal officer for Disaster Management:

Updated Contact Details of Disaster Management Nodal Officers of Power Utilities of NER is enclosed as Annexure-D.19 for finalization.

NERLDC may please deliberate.

D. 20 Submission of Data for Wind Turbine Generator:

Submission of States Wind Turbine Generator (WTG)-wise data pertaining to Low Voltage Ride Through (LVRT) as directed by Hon' CERC vide ROP in Petition no. 237/MP/2017. Format for submission of data is enclosed as Annexure-D.20.

NERLDC may please deliberate.

D. 21 Non-furnishing of weekly SEM time drift report:

Details enclosed as Annexure.D.21

NERLDC may please deliberate.

D. 22 Replacement/Installation of high time drift SEMs:

Detailed list enclosed as Annexure-D.22

NERLDC may please deliberate.

D. 23 SEM error:

Rectification of SEM error / configuration at Kopili, , Dharmanagar 132 kV S/S

NERLDC may please deliberate.

D. 24 5 min metering:

As per CERC order dated 16 July,18. Sixteen no of 5 min SEMs along with two no of compatible DCDs to be arranged for NTPC and LOKTAK(Letter No NERLDC/MO/107/ dated 08/03/2019 is enclosed as Annexure-D.24.

NERLDC may please deliberate.

Any other item:

Date and Venue of next OCC

It is proposed to hold the 155th OCC meeting of NERPC on second week of April, 2019. The date & exact venue will be intimated in due course.

पावर सिस्टम ऑपरेशन करपोरेशन लिमिटेड
(भारत सरकार का उद्यम)
POWER SYSTEM OPERATION CORPORATION LIMITED
(A Government of India Enterprise)



उत्तर पूर्वी क्षेत्रीय भार प्रेषण केंद्र : लोअर नंगरा, लापालांग, शिलांग-793006, (मेघालय)
North Eastern Regional Load Despatch Centre: Lower Nongrah, Lapalang, Shillong - 793006, (Meghalaya)
Ph : 0364-2537470, 2537427, Fax - 2537486 Website : www.nerldc.org, Email - nerldc@posoco.in, CIN : U40105DL2009GOI188682

संदर्भ : उपक्षेत्रीय/एस.ओ-II/ 2798
Ref : NERLDC/SOII/ 2798

दिनांक/Date: 22.02.19

सेवा में/To: General Manager
AGTCCPP (NEEPCO)
Laxmipur, Tripura - 799210

प्रतिलिपि/Copy to: General Manager (I/C) (O&M),
NEEPCO Ltd, Brookland Compound,
Lower New Colony, Shillong - 793003.

विषय/Sub: Low Frequency Oscillations at Agartala PMU

महोदय,

It is for your kind information that low frequency oscillations in Voltage have been observed at Agartala PMU on 21st Feb 2019. Similar oscillations have been observed earlier and same had been communicated as well.

Low frequency oscillations of about 0.3 Hz were observed in the voltage of Agartala PMU on 21st Feb 2019. Such kind of oscillations, if undamped, pose a threat to system stability and this can result in large scale disturbances. The units of AGTCCPP were identified in earlier cases as the source of these oscillations. Also it was decided to install DAVR to mitigate the issue of such oscillations.

It is requested to intimate which machines are causing the oscillations.

Also, it is requested to mention whether new DAVR have been installed in all the units of AGTCCPP by 26.02.19.

धन्यवाद एवं सादर सहित।

अमरेश 22.02.19

भवदीय /Yours Sincerely

अ.मल्लिक / A. Mallick)

व. महाप्रबंधक (एस.ओ-2) Sr.G.M. (S.O.-II)

Root cause study of oscillation observed at Agartala PMU on 26-02-19

Oscillation at the Agartala Bus was being observed continuously since 23:00 hrs (approx.) of 26-02-2019. The oscillation was suspected to be caused by AGTCCPP generation. An operation to pin point the exact root cause of the oscillation was carried out in the control room. At 10:23 Hrs, Unit-1 generation of AGTCCPP was decreased to half its capacity (approx. 12 MW) which in turn showed a rise in oscillation. As per the PMU plots of Agartala substation oscillating frequency of 0.4 Hz and peak to peak voltage magnitude of 0.58 kV was observed. Meanwhile the MVAR for unit-1 was seen fluctuating from 7 MVAR to - 0.25 MVAR (as shown in the plot below). As unit-1 was instructed to increase its generation to full load the oscillation was observed to be subsiding.

Subsequently, Unit-2 generation of AGTCCPP was instructed to reduce its generation. AGTCCPP personnel decreased the generation to 70% capacity (approx. 15 MW), which brought back the oscillation but with a frequency of 0.2 HZ.

Lastly, Unit-3 generation of AGTCCPP was instructed to reduce its generation. AGTCCPP personnel decreased the generation to approx. 16 MW. There is no oscillation observed when the generation of unit - 3 was reduced. Minor fluctuation was observed in the MVAR of unit 2 & 3.

Thus as per observation unit 1 generates oscillation when on low load condition and a different frequency oscillation is generated by unit 2 when on low loaded condition. In PMU plots shown below, two parts of instability alert being observed first due to unit-1 and the later due to the variation of unit-2.

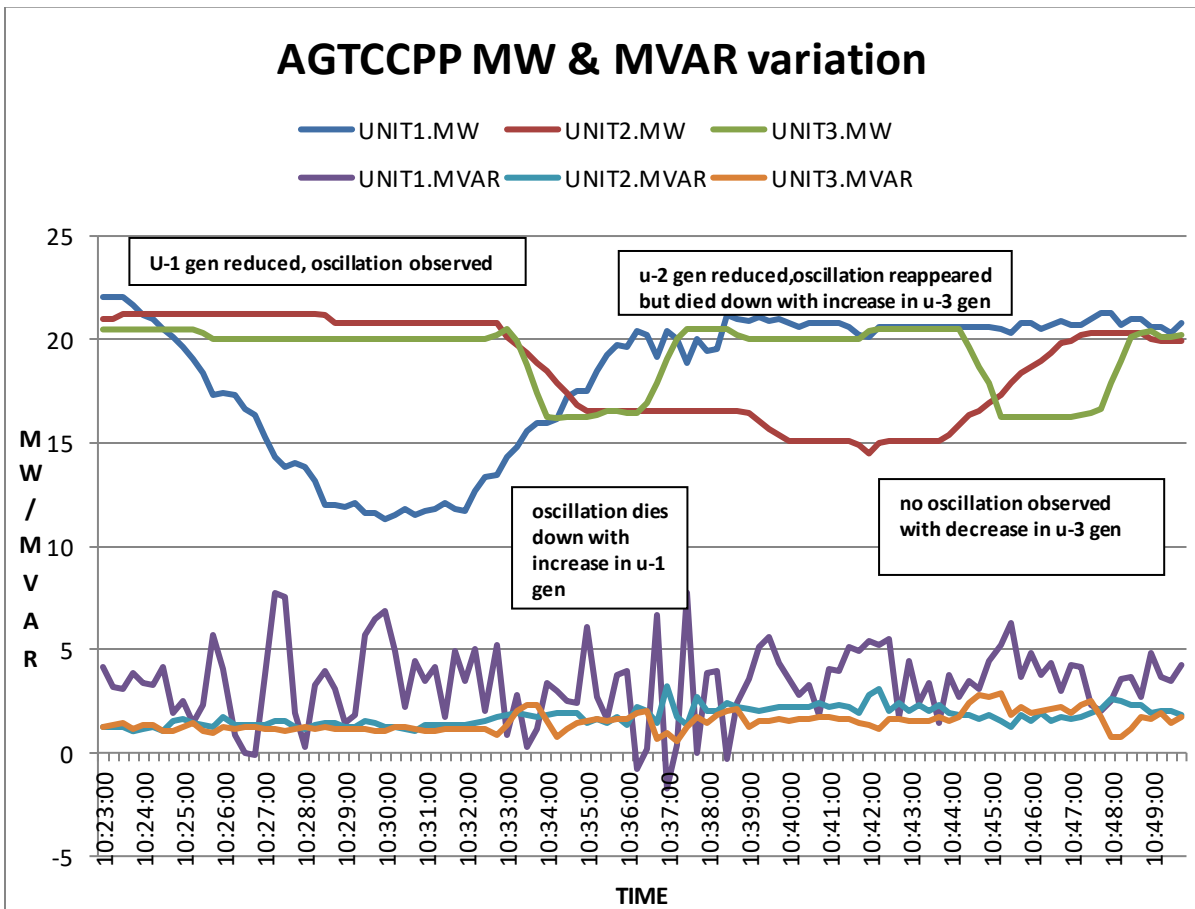
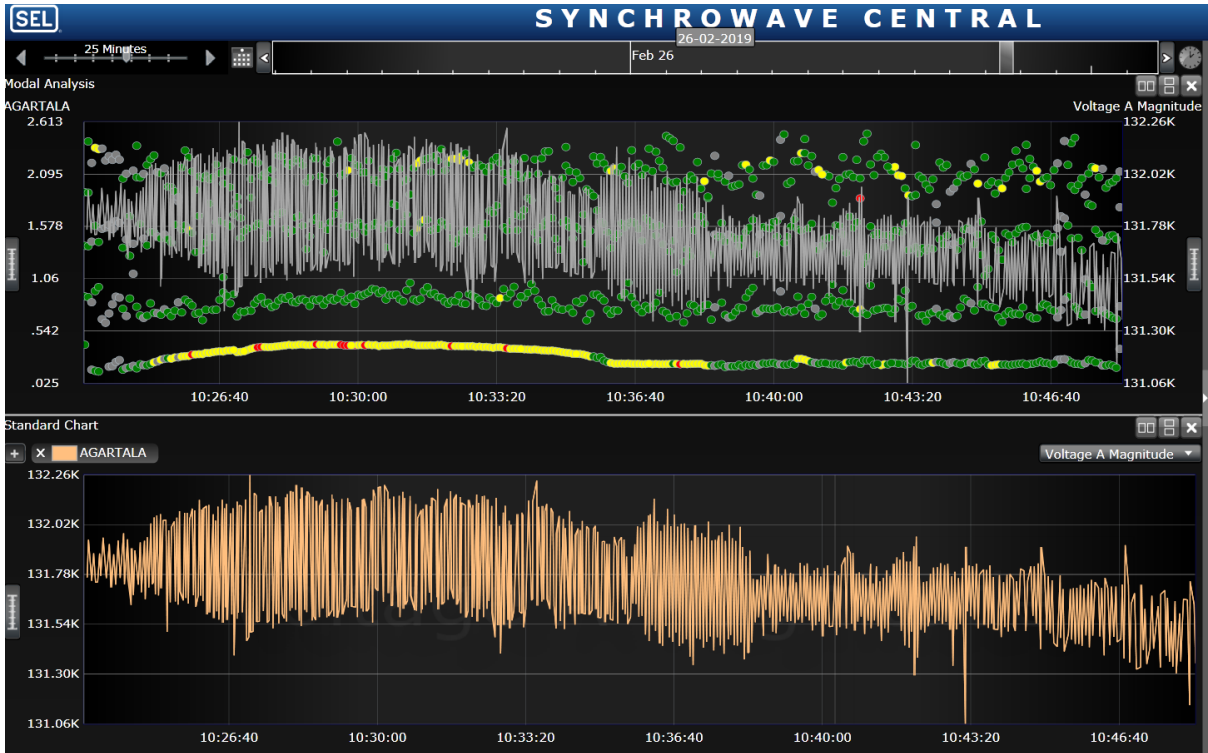

PRIORITY LIST FOR DISTRIBUTION OF DCD

SL.NO	LOCATION	QTY.
	PRIORITY	
1	BNC	1
2	SONABIL	1
3	KAMENG	1
4	PARE	1
5	CHIMPU	1
6	MANIPUR	1
7	KOHIMA	1
8	MOKUKCHANG	1
9	BYRNIHAT	1
10	RC NGAR	1
11	KOLASIB	1
12	Doyang	1
13	MARIANI	1
14	NTPC	1
15	BALIPARA	1
16	NIRJULI	1
	TOTAL	16

STATUS OF DATA VALIDATION OF NERTS STATIONS AS PER 12TH NeTEST MEETING

Sl. No.	Name of RTU	Status of Data validation	Date of Validation
1	Aizawl	Joint Verification done; Missing Address to be implemented in Site	21-02-2019
2	Badarpur	Joint Verification done; Missing Address to be implemented in Site	25-02-2019
3	Balipara	Joint Verification done; Missing Address to be implemented in Site	08-01-2019
4	BNCHVDC	Not done	NA
5	Bongaigoan	Joint Verification done; Missing Address to be implemented in Site	09-02-2019
6	Dimapur	Joint Verification done; Missing Address to be implemented in Site	28-02-2019
7	Haflong	Joint Verification done; Missing Address to be implemented in Site	26-02-2019
8	Imphal	Completed	28-02-2019
9	Itanagar(Nirjuli)	Joint Verification done; Missing Address to be implemented in Site	25-02-2019
10	Jiribam	Joint Verification done; Missing Address to be implemented in Site	26-02-2019
11	Khleiriat	Joint Verification done; Missing Address to be implemented in Site	27-02-2019
12	Kopili-Ex	Not done	NA
13	Kumarghat	Joint Verification done; Missing Address to be implemented in Site	27-02-2019
14	Mariani	Joint Verification done; Missing Address to be implemented in Site	28-02-2019
15	Melriat	Completed	26-02-2019
16	Misa	Joint Verification done; Missing Address to be implemented in Site	08-01-2019
17	Mokokchung	Joint Verification done; Missing Address to be implemented in Site	28-02-2019
18	Namsai	Not done	NA
19	Roing	Not done	NA
20	Salakati	Not done	NA
21	Silchar	Not done	NA
22	Tezu	Not done	NA
23	Ziro	Completed	27-02-2019

932/2019/LR

Annexure- D.8 (I)

CENTRAL ELECTRICITY REGULATORY COMMISSION
Ground Floor, Chanderlok Building,
36, Janpath, New Delhi-110 001

File No. Admn.-11021/1/2018-CERC

Dated : 21.02.2019

To

The Executive Director,
 North Eastern Load Despatch Centre (NERLDC),
 Power System Corporation Operation Limited (POSOCO)
 POWERGRID Complex, Dongteih, Lower Nongrah,
 Lapalang, Shillong- 793006, Meghalaya, India

**Sub: Compliance of Commission's Order dated 17th October, 2017 in
 Petition No. 16/SM/2015 - reg.**

The Commission vide Order dated 17.10.2017 in Petition No. 16/SM/2015 had given the following directions:

"29. POSOCO has sought clarity on the following aspects: (i) whether to allocate the power in a first cum first served manner or pro rata, (ii) whom to give URS power if number of beneficiaries are overdrawing and the same is diabolically changing, (iii) when to withdraw in case some beneficiaries start under-drawing and (iv) how much quantum of URS to be allocated to whom. In regards to how much quantum to be allocated to whom, we have already held that "the concerned RLDC shall schedule such URS power to the requesting beneficiaries in proportion to the quantum requested by them". Further we observe that URS scheduling shall be based on the requisition and under-drawal/over-drawal by a beneficiary as of now since beneficiary has no relevance to the scheduling of URS.

Regarding other questions we have perused the Operating Procedure of SRLDC available on SRLDC website which is extracted as under:

"9.2 ALLOCATION OF UN-REQUISITIONED SURPLUSES....The URS ReAllocation will be on first come first serve basis however the request received in the same time block will be treated at par & shared on proportional basis".

Accordingly, we direct that respective RLDCs should decide the protocol in this regard after consultation with ISGSs and beneficiaries in the region and place the protocol in the public domain for the information and compliance of all concerned."

पोसोको POSOCO

26 FEB 2019

उपक्षेत्राधिकारी NERLDC
 शिलांग Shillong

क. श. 211

SRM(SO-2)
 Prasant Achmon
 Para 2
 21/02/19

→ Himani
 21/02/19

2. The report regarding compliance of the above direction has not been received in the Commission. You are, therefore, requested to ensure compliance of the said direction within 15 days from the date of receipt of this communication failing which the matter will be placed before the Commission for appropriate orders.

3. The compliance may be uploaded in the Saudamini Portal of CERC. For the purpose you may contact E-Court Help Desk (011-23353503/Ext. 260 or 446) of CERC Or e-mail to acmis@cerc.gov.in for any assistance.

4. An early action in the matter may be taken in compliance of Commission's directions.

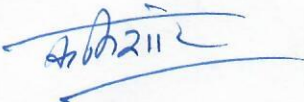
(Kamal Kishor)
Asstt. Chief (Legal)
Tel: 23353503

Protocol of URS Scheduling in NERLDC

Definition of URS as per The Central Electricity Regulatory Commission (Ancillary Service Operations) Regulation, 2015: *“The Reserve capacity in a generating station that has not been requisitioned and is available for despatch, and is computed as the difference between the declared capacity and its total schedule under long term, medium term and short term transactions as per the relevant regulation of the commission”.*

Procedure:

1. **Eligibility:** Original beneficiary of a particular generating station is eligible to submit request for URS from that particular generating station. It can ask for URS in a particular time block only if its requisition of power from that generator in the time block is equal to its entitlement.
2. **URS Request:** URS request by a beneficiary is to be submitted through the generator from which URS is sought. Generator would then request NERLDC for implementation of URS in the schedule with a copy of consent of original beneficiary.

Alternatively,

The URS request can also be processed without any real time consent, if standing consent from the generator and the original beneficiary (both surrendering and requesting) is already made available at NERLDC.

3. URS Approval :

- a. If RRAS revision is already incorporated before submission of URS request by beneficiary, the same amount will not be allowed under URS.
- b. The URS allocation will be on first come first served basis however the request received in the same time block will be treated at par & allocated on proportional basis.
- c. Due to any reason (withdrawal of surrender of power or DC revision) if margin is reduced, curtailment in URS will be in the ratio of URS power allocated.

Annexure 3 (a):

Underdrawal of States and Over Injection of ISGS during High Frequency:

Date	Frequency Violation no.	Regional Entity	Frequency (Hz)	Drawal Schedule (MW)	Actual Schedule (MW)	Actual Deviation (MW)
24-02-19	6729	MEGHALAYA	50.16	232	220	-12
		TRIPURA		106	43	-63
		MIZORAM		61	54	-7
24-02-19	6727	AP	50.18	100	89	-11
		NAGALAND		97	90	-7
17-02-19	6715	AP	50.17	101	86	-15
		ASSAM		610	579	-31
		TRIPURA		54	28	-26
		MANIPUR		79	70	-9
		MIZORAM		53	38	-15
		NAGALAND		63	53	-10
15-02-19	6708	TRIPURA	50.10	58	30	-28
		MANIPUR		91	81	-10
		MIZORAM		66	56	-10
15-02-19	6707	AP	50.20	90	78	-12
		MEGHALAYA		191	175	-16
		TRIPURA		49	39	-11
		MANIPUR		85	79	-6
		MIZORAM		65	55	-10
		NAGALAND		77	69	-8
11-02-19	6698	BgTPP	50.22	250	285	35
11-02-19	50.22	ASSAM	50.22	608	556	-52
		MEGHALAYA		221	208	-13
10-02-19	6692	TRIPURA	50.08	46	25	-21
		AP		96	65	-33
		MANIPUR		96	79	-17
		MIZORAM		38	36	-2
		NAGALAND		57	50	-7
09-02-19	6690	BgTPP	50.18	250	285	35
		AP		88	82	-6
		MEGHALAYA		221	211	-10
		MANIPUR		146	137	-9
		MIZORAM		65	39	-26
08-02-19	6689	NAGALAND	50.20	96	75	-21
		MIZORAM		62	49	-13
07-02-19	6687	ASSAM	50.11	790	742	-48
				78	55	-23

पावर सिस्टम ऑपरेशन कारपोरेशन लिमिटेड
(भारत सरकार का उद्यम)
POWER SYSTEM OPERATION CORPORATION LIMITED
(A Government of India Enterprise)



उत्तर पूर्वी क्षेत्रीय भार प्रेषण केंद्र : लोअर नोंग्राह, लापालांग, शिलांग - 793 006, (मेघालय)
North Eastern Regional Load Despatch Centre : Lower Nongrah , Lapalang, Shillong - 793 006, (Meghalaya)
Ph : 0364 2537470, 2537427, fax - 2537486 Website : www.nerlhc.org, Email- nerlhc@posoco.in, CIN : U40105DL2009GOI188682

संदर्भ/Ref: NERLDC/SO-I/OTPC/2019/2846

दिनांक/Date : 07-03-2019

To,
The Head of the Project,
OTPC Power Plant
Udaipur-Kakraban Road, Palatana P.O.,
District Gomati, Tripura-799105

विषय/SUB: Multiple Emergency Shutdown availed by OTPC Palatana ISGS.

Sir,

This is to bring to your notice that OTPC Palatana has availed emergency shutdown of Module II since 23:28 hrs of 06-03-2019. Following points may kindly be noted regarding the said shutdown:

- It was informed that GT#2 Axial compressor efficiency degradation has happened more than 6% and OEM GE has recommended to immediately go for off-line compressor washing as a statutory requirement, failing which compressor surge can occur, damaging the compressor blades. From the above, it appears that the process of degradation has taken place over a period of time and hence, work mentioned is that of planned nature and Palatana could have planned the shutdown in 153rd OCC meeting.
- The request for emergency shutdown was received via email by NERLDC on 19:51 Hrs of 05/03/19. OTPC Palatana had given day-ahead DC w.r.t. only one module for 07/03/19, before receiving approval for the said shutdown, which is not a right practice.
- Also, in last two months, OTPC Palatana has availed emergency shutdown of Module I twice for works which could have been planned in advance and availed as planned shutdown in OCC. Details of the emergency shutdown are as follows:

Sl. no.	Name of Unit	Outage		Restoration		Reasons
1	Palatana GTG I	06-Jan-19	23:26	09-Jan-19	18:41	ESD for replacement of gas turbine inlet air filters.
2	Palatana STG I	06-Jan-19	23:26	09-Jan-19	22:47	ESD for replacement of gas turbine inlet air filters.
3	Palatana GTG I	10-Feb-19	23:28	12-Feb-19	12:34	ESD for replacement of gas turbine inlet air filters.
4	Palatana STG I	10-Feb-19	23:27	12-Feb-19	16:13	ESD for replacement of gas turbine inlet air filters.

OTPC Palatana is requested to avail planned shutdown of the units after due discussion in OCC Meetings before the parameters reach emergency condition. Planned shutdown of the units shall help the NER constituent states in arrangement of power from elsewhere and maintain the Load-Generation balance of the region.

This is for your kind information and necessary action at your end please.

Yours sincerely,

04/3/2019

(आर. सूत्रधार /R. Sutradhar)

व. महाप्रबंधक (एस.ओ-1)/Sr. GM (S.O-1)

उ.पू.क्षे.भा.प्रे.के/NERLDC.

Copy To:

1) सदस्य सचिव, उपक्षेविस/ MS, NERPC

2) मुख्य महाप्रबंधक (उ.पू.क्षे.भा.प्रे.के)

/ CGM (NERLDC)

पावर सिस्टम ऑपरेशन कर्पोरेशन लिमिटेड
(भारत सरकार का उद्यम)
POWER SYSTEM OPERATION CORPORATION LIMITED
(A Government of India Enterprise)



उत्तर पूर्वी क्षेत्रीय भार प्रेषण केंद्र : लोअर नंगरा, लापालांग, शिलांग-793006, (मेघालय)
North Eastern Regional Load Despatch Centre: Lower Nongrah, Lapalang, Shillong - 793006, (Meghalaya)
Ph : 0364-2537470, 2537427, Fax - 2537486 Website : www.nerlhc.org, Email - nerlhc@posoco.in, CIN : U40105DL2009GOI188682

Ref: NERLDC/ GM /33/ 2878

Dt. 07.03.2019

To
The General Manager
KHEP, NEEPCO Ltd., Umrangso

Copy to:

1. The General Manager (I/C) (O&M), NEEPCO, Lower New Colony, Shillong-3
2. The Chief General Manager (I/C), NERTS, POWERGRID, Shillong-6
3. The Member Secretary, North Eastern Regional Power Committee, NERPC Complex, Shillong - 6
4. CGM (I/C), NERLDC, POSOCO, Shillong - 6

Sub : Lack of information w.r.t. tripping of 132 kV Kopili - Khandong-II on 06.03.19

Dear Sir(s),

This is to inform you that, the following misoperation has been observed at our end w.r.t. 132kV Kopili - Khandong - II transmission line on 06.03.19:

1. At around 1900 Hrs it had been observed by our Evening Shift personnel that there was no power flow through the 132kV Kopili - Khandong - line II implying that the line might be in open condition. However, no information was available with NERLDC regarding tripping/ outage of the same.
2. The matter communicated to both end substation shift-in-charges; but it was initially denied that the line was in open condition. Subsequently it was informed that the line was in idle charge condition from Khandong end.
3. Following which, since there was no information available with either end substations regarding any reasons for outage/ faulty condition; in view of overall optimum grid functioning, instruction/ code was issued by NERLDC for initially opening from Khandong end (since, as informed by them, no synchronizing facility is available at Kopili end) at 19:10 hrs; following which code for charging from Kopili end and synchronizing at Khandong end was issued by NERLDC at 19:13 hrs. However, while charging from Kopili end, the said line tripped and it was informed by Kopili that the reason of tripping was due to SOTF (Details as sought is still awaited).

Now, as per the CEA (Grid Standards) Regulations, 2010; discrepancy/ violation of Grid Standard has been observed w.r.t. the following clauses of the standard; which may please be noted:

1. As per Cl. No. 6(1), **Coordination in Operations:** Quote: No Entity shall introduce or take out the element of the grid without the concurrence of the Appropriate Load Despatch Centre except in case of imminent risk of safety of plant and personnel in which case it must intimate Appropriate Load Despatch Centre giving reasons therefore. Unquote
2. Further, as per Cl. No. 12(1), **Reporting of events affecting grid operation:** Quote: (1) Any tripping of generating unit or transmission element, along with relay indications, shall be promptly reported by the respective Entity to the Appropriate Load Despatch Centre in the reporting formats as devised by the Appropriate Load Despatch Centre.

Therefore, in view of safety and security of the interconnected Grid and co-ordinated operation, it is hereby requested immediate follow-up may please be carried out w.r.t. the said discrepancy and such event shall be avoided in future.

This is for your kind information and further necessary action please.

Thanking you.

Yours faithfully



07/3/2019
(राजिब सूत्रधर)

वरिष्ठ महाप्रबंधक (एस.ओ-1)

उ.पू.क्षे.भा.प्रे.के, शिलांग

Study for Connection of 132 kV Itanagar – Lekhi (Naharlagun) S/C

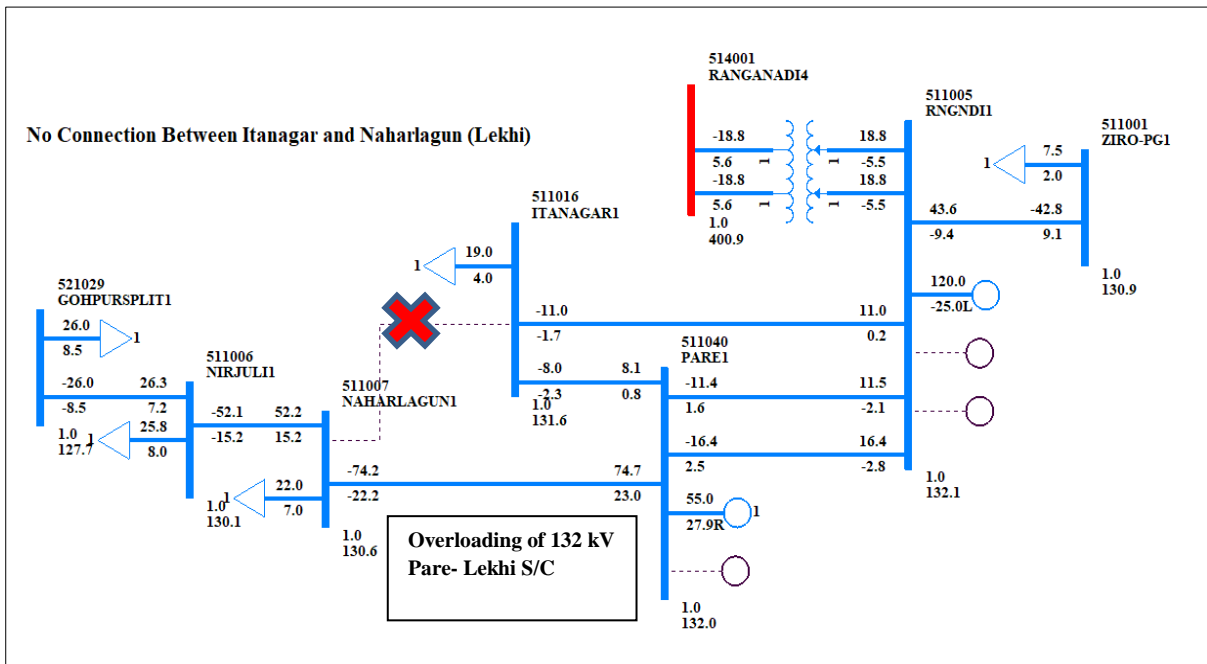
132 kV Itanagar – Lekhi (Naharlagun) S/C is kept open which leads to overloading of 132 kV Pare- Lekhi S/C under various conditions.



Connecting 132 kV Itanagar – Lekhi (Naharlagun) S/C leads to decrease in loading of 132 kV Pare – Lekhi by about 11 MW, the same power being transferred from 132 kV Itanagar to 132 kV Lekhi.

Also, in case of tripping of 132 kV Pare – Lekhi S/C, 132 kV Itanagar – Lekhi will act as an alternate path for power supply to Lekhi Area of AP Power system, thereby increasing the reliability of the grid.

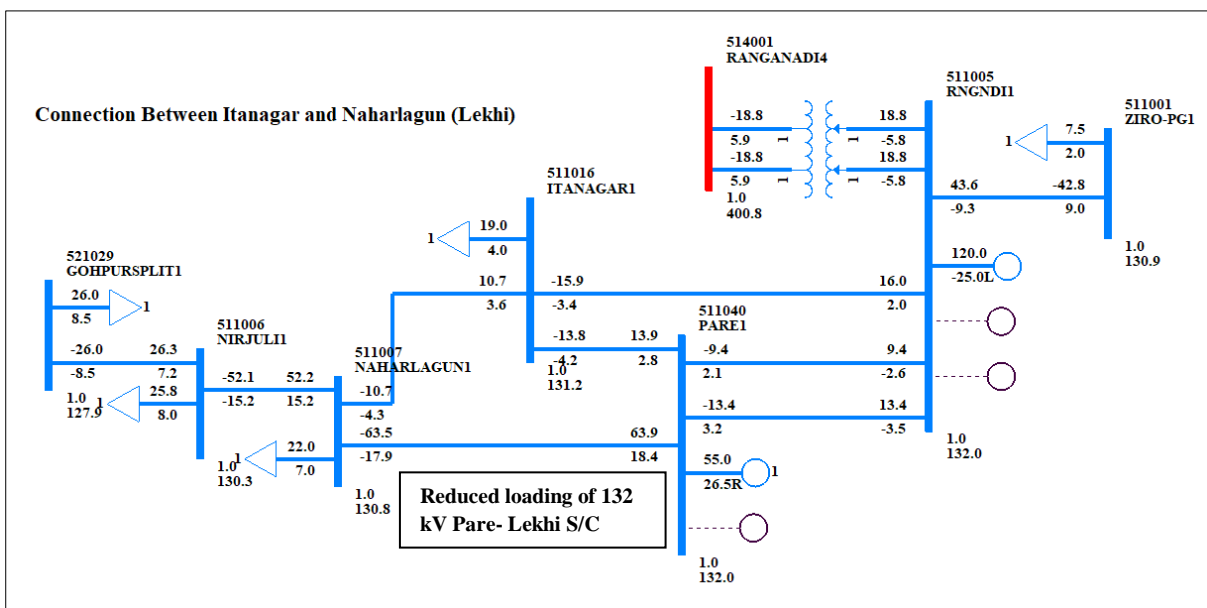

It is therefore desired to kept the link 132 kV Itanagar – Lekhi (Naharlagun) closed in all conditions

Tripping details of 132Kv Imphal (PG) – Imphal (MA):

Sl. no.	Element Name	Outage Date	Outage Time	Revival Date	Revival Time	Reason End 1	Reason End 1
1.	Imphal (Manipur) - Imphal (PG) – II	26-Jan-19	05:37:00	26-Jan-19	06:08:00	Tripping is in Yurembam end only due to fault in 132/33 kV Transformer-I at Kongba SS	No Tripping
2.	Imphal (Manipur) - Imphal (PG) – I	26-Jan-19	05:37:00	26-Jan-19	06:08:00	Tripping is in Yurembam end only due to fault in 132/33 kV Transformer-I at Kongba SS	No Tripping
3.	Imphal (Manipur) - Imphal (PG) – I	29-Jan-19	17:43:00	29-Jan-19	17:51:00	No tripping	Over current
4.	Imphal (Manipur) - Imphal (PG) – II	29-Jan-19	17:43:00	29-Jan-19	17:52:00	No Tripping	Over current
5.	Imphal (Manipur) - Imphal (PG) – II	08-Feb-19	18:25:00	08-Feb-19	18:58:00	Details awaited	No Tripping
6.	Imphal (Manipur) - Imphal (PG) – I	08-Feb-19	18:25:00	08-Feb-19	19:36:00	Details awaited	No Tripping
7.	Imphal (Manipur) - Imphal (PG) - I	19-Feb-19	13:45:00	19-Feb-19	14:02:00	No trip	fault at 33 kV end, Details awaited
8.	Imphal (Manipur) - Imphal (PG) - I	19-Feb-19	13:45:00	19-Feb-19	13:51:00	fault at 33 kV side , Details awaited	No trip
9.	Imphal (Manipur) - Imphal (PG) - I	23-Feb-19	19:39:00	23-Feb-19	20:02:00	Details awaited	No tripping
10.	Imphal (Manipur) - Imphal (PG) - I	23-Feb-19	19:39:00	23-Feb-19	20:02:00	Details awaited	No tripping

पावर सिस्टम ऑपरेशन करपोरेशन लिमिटेड
(भारत सरकार का उद्यम)
POWER SYSTEM OPERATION CORPORATION LIMITED
(A Government of India Enterprise)



उत्तर पूर्वी क्षेत्रीय भार प्रेषण केंद्र : लोअर नंगरा, लापालांग, शिलांग-793006, (मेघालय)
North Eastern Regional Load Despatch Centre: Lower Nongrah, Lapalang, Shillong - 793006, (Meghalaya)
Ph : 0364-2537470, 2537427, Fax - 2537486 Website : www.nerlhc.org, Email - nerlhc@posoco.in, CIN : U40105DL2009GOI188682

संदर्भ : उपक्षेत्रीय/एस.ओ-11/ 2539
Ref : NERLDC/SOII/2539

दिनांक/Date: 30.01.19

सेवा में/To:

1. General Manager, SLDC, MSPCL, Imphal, Manipur – 795001
2. General Manager, Substation Circle, MSPCL, Imphal, Manipur – 795001

प्रतिलिपि/Copy to:

1. Member Secretary, NERPC, Shillong- 793006

बिषय/Sub: Detailed Analysis & Furnishing Event information for disturbance in Capital & Ningthoukhong areas of Manipur Power System.

महोदया / महोदय,

As you are aware that disturbance of Category GD-1 occurred in Capital area of Manipur Power System at 05:37 Hrs on 26.01.19 and at 17:43 Hrs on 29.01.19 due to tripping of 132 Imphal (MSPCL) – Imphal (PG) D/C only at 132 Imphal (MSPCL).

Disturbance of Category GD-1 occurred in Ningthoukhong area of Manipur Power System 07:13 Hrs on 26.12.18 and at 14:06 Hrs on 27.01.19 due to tripping of 132 Loktak – Ningthoukhong line only at 132 kV Ningthoukhong.

You are requested to find out the root cause of the events and take appropriate action to resolve the issue at the earliest. It is also requested to intimate the root cause and action(s) taken at your end.

For analysis purpose, it is requested to upload Disturbance Recorder (DR), Event Logger (EL) outputs of 132 kV Imphal (MSPCL) and 132 kV Ningthoukhong for the events mentioned above along with a First Information Report (FIR) in Tripping Monitoring Portal (<http://103.7.131.234/Trippingnew/Account/Login.aspx>).

धन्यवाद एवं सादर सहित

भवदीय / Yours sincerely,

अमरेश 30.01.19

(अ.मल्लिक / A. Mallick)

व. महाप्रबंधक (एस.ओ-2) Sr. G.M. (S.O.-II)

पावर सिस्टम ऑपरेशन करपोरेशन लिमिटेड

(भारत सरकार का उद्यम)

POWER SYSTEM OPERATION CORPORATION LIMITED

(A Government of India Enterprise)



उत्तर पूर्वी क्षेत्रीय भार प्रेषण केंद्र : लोअर नँगरा, लापालांग, शिलांग-793006, (मेघालय)

North Eastern Regional Load Despatch Centre: Lower Nongrah, Lapalang, Shillong - 793006, (Meghalaya)

Ph : 0364-2537470, 2537427, Fax - 2537486 Website : www.nerldc.org, Email - nerldc@posoco.in, CIN : U40105DL2009GOI188682

संदर्भ : उपक्षेत्रीय/एस.ओ-II/ 2818

दिनांक/Date: 28.02.19

Ref : NERLDC/SOII/ 2818

सेवा में/To:

1. General Manager, SLDC, MSPCL, Imphal, Manipur – 795001
2. General Manager, Substation Circle, MSPCL, Imphal, Manipur – 795001

प्रतिलिपि/Copy to:

1. Member Secretary, NERPC, Shillong- 793006

विषय/Sub: Detailed Analysis & Furnishing Event information for disturbance in Capital area of Manipur Power System.

Ref: Letter No NERLDC/SO-II/2539

महोदया / महोदय,

Please refer the letter no NERLDC/SO-II/2539 dated 30.01.19. We have not received any reply from your end.

As you are aware that 3 nos. of disturbance of Category GD-1 in the month of Feb'19 and 2 nos. of disturbance of Category GD-1 in the month of Jan'19 occurred in Capital area of Manipur Power System due to tripping of 132 Imphal (MSPCL) – Imphal (PG) D/C only at 132 Imphal (MSPCL).

Details received from site are as follows:

1. At 18:25 Hrs on 8th Feb'19 – Suspected downstream fault
2. At 13:45 Hrs on 19th Feb'19 – Fault in 33 kV side
3. At 19:39 Hrs on 23rd Feb'19 – Suspected downstream fault

You are requested to find out the root cause of the events and take appropriate action to resolve the issue at the earliest. It is also requested to intimate the root cause and action(s) taken at your end & the schedule for the maintenance activities to reduce the downstream faults due to cable faults, CT blast etc.

For analysis purpose, it is requested to upload Disturbance Recorder (DR), Event Logger (EL) outputs of 132 kV Imphal (MSPCL) for the events mentioned above & events mentioned in the previous letter along with a First Information Report (FIR) in Tripping Monitoring Portal (<http://103.7.131.234/Trippingnew/Account/Login.aspx>).

धन्यवाद एवं सादर सहित

भवदीय / Yours sincerely,

अमरेश 28.02.19

(अ.मल्लिक / A. Mallick)

व. महाप्रबंधक (एस.ओ-2) Sr. G.M. (S.O.-II)



Annexure-D.16

nerldc shillong <nerldccontrolroom@gmail.com>

Delay in collection of relay details of remotely controlled S/Ss

1 message

nerldc shillong <nerldccontrolroom@gmail.com>

Sun, Feb 24, 2019 at 1:52 PM

To: nerts cpcc <nerts_cpcc@powergrid.co.in>, nerts_rtamc@powergrid.co.in

Cc: V Suresh <vsuresh@posoco.in>, kaikhochin valte <kaikhochin@gmail.com>, R Sutradhar <rajibsutradhar@posoco.in>, S C De <scde@posoco.in>, Amresh Mallick <amareshmallick@posoco.in>

Sir,

This is to bring to you kind notice that relay details from site is not fully accessible from RTAMC, due to which collection of relay details after any line tripping are getting delayed for the remotely controlled S/Ss of POWERGRID. Which results delay in issue of closing code from NERLDC and hampers system security. As example

Today on 24.02.19 132kV Nirjuli - Lekhi line tripped at 11:05 Hrs but due to the delay in collection of tripping detail from Nirjuli, code for closing the line was issued at 11:20 Hrs only.

Hence necessary action may kindly be taken to reduce such delay.

सादर /Regards,

पाली प्रभारी/Shift-In-Charge
उत्तर पूर्वी भार प्रेषण केंद्र शिलांग
North Eastern Load Dispatch Centre Shillong



दूरभाष / Contact No- 0364-2537481/2537427/8415900659/ 8415900660

यू एल डी सी फोन नम्बर/ ULDC PH NO- 23640028/23640059

शेड्यूलिंग डेस्क/ Scheduling desk: 0374-2537470/ 23640027(ULDC)

फैक्स नम्बर /Fax- 0364- 2537486/2537470

**DISASTER MANAGEMENT - LIST OF CONTACT DETAILS OF NODAL OFFICERS/SECOND IN COMMAND UPDATED
ON 05/03/2019**

Region/SLDC	Name	Designation	Tel. Nos.	Mobile No.	Fax No.	E-mail Address
NERLDC						
Nodal Officer	R. Sutradhar	Sr. GM(SO -I)	0364-2535710	9436302714	0364-2537470	rajibsutradhar@posoco.in
Second in Command	A Mallick	Sr. GM(SO-2)	0364-2535481	9436302720	0364-2537470	amareshmallick@posoco.in
Arunachal Pradesh SLDC						
Nodal Officer	N. Perme,	EE, SLDC	-	9436288643	-	sldcitnagar@gmail.com
Second in Command	Domo Kamduk	A.E (E)	0360-2292160	9436671717	0360-2214358	sldcitanagar@gmail.com
Assam/ AEGCL SLDC						
Nodal Officer	Khireswar Gogoi	DGM, LDC	0361-2381287	9435360066	0361-2387929	kgogoi59@gmail.com
Second in Command	Bimal Chandra Borah	AGM, LDC	0361-2381287	9435119248	0361-2387929	bimalchandraborah@gmail.com
Manipur SLDC						
Nodal Officer	L Dinesh Kumar Singh	GM (SLDC)	0385-2436177	9862464974	-	gmsldcmanipur@gmail.com
Second in Command	Liashram Ritu	DGM (System Operation), SLDC	0385-2436192	9612882984	-	redrit03@gmail.com
Meghalaya/ MeSEB SLDC						
Nodal Officer	Shri F.E.Kharshiing	Superintending Engineer(SLDC)	-	9863066960	-	frederickek@gmail.com
Second in Command	Shri T.Gidon	Executive Engineer	-	9774479956	-	gidon@rediffmail.com
Mizoram SLDC						
Nodal Officer	Lalbiaksanga	Superintending Engineer, SLDC	0389 2311397	9436140932	-	mSLDC.circle@gmail.com
Second in Command	Benjamin L. Tlumtea	Sr. Executive Engineer, SLDC	0389 2328322	9436151424	-	bltlumtea@yahoo.com
Nagaland SLDC						
Nodal Officer	Er. Nitovi A Wotsa	Executive Engineer (Transmission & SLDC)	-	9436004928	-	nitoviv@gmail.com
Second in Command	Er. Debabrata Chakraborty	Sub-Divisional Officer (SLDC)	-	7577950317	-	chakra2500@gmail.com

**DISASTER MANAGEMENT - LIST OF CONTACT DETAILS OF NODAL OFFICERS/SECOND IN COMMAND UPDATED
ON 05/03/2019**

Region/SLDC	Name	Designation	Tel. Nos.	Mobile No.	Fax No.	E-mail Address
Tripura SLDC						
Nodal Officer	Er. Anil Debbarma	DGM, Electrical	0381-2356470	7005709452	0381-2350795	anildebbarma123@gmail.com
Second in Command	Er. Mrinal Pal	Manager, Electrical	0381-2356470	9436137022	-	mrinalpaulnit@gmail.com
NERTS						
Nodal Officer	U. Katak	Sr. GM	-	9435505418	-	u.katak@powergridindia.com
Second in Command	P. Kanungo	Sr. GM	0364-2537328	9436302823	Nil	kanungo_p@yahoo.com
NEEPCO						
Nodal Officer	B. Goswami	Sr. Mgr.	0364-2504355	9436163983	0364-2221789	bhaskargoswami@rediffmail.com
Second in Command	Joypaul	Sr. Mgr.	0364-2226707	943557772	0364-2221789	joypal_roy@rediffmail.com
NHPC						
Nodal Officer	K. T. Rajah Pandian	General Manager(Electrical)	03879-261739	7085057135	-	ktrajahpandian@yahoo.co.in
Second in Command	N. Yugandhar	Senior Manager (E & C)	03879-261237	9800003819	-	loktakphop@gmail.com
NETC						
Nodal Officer	Sh. D.K. Sarma	Sr. Consultant, Guwahati.	-	9471001032 / 8638481689	-	dkarma@netcindia.in
Second in Command	Ratan Singh Basnet	Assistant Manager, Guwahati.	-	8811072489 / 7002809257	-	ratansinghasnet@netcindia.in
NTPC						
Nodal Officer	Sri Chandan Chakraborty	Chief General Manager	03661 282754/ 34	9650994355	03661 282726	chandanchakraborty@ntpc.co.in
Second in Command	Sri Rakesh Kumar	General Manager (O&M)	03661 282712	9431011344	-	rakeshkumar12@ntpc.co.in
OTPC						
Nodal Officer	Bibek Roy	Plant In-Charge	0381 2363875	8794006803	3812363714	bibek.roy@otpcindia.in
Second in Command	Narendra Kumar Gupta	Sr. Manager - Operation	0381 2363806	9774233426	3812363714	nk.gupta@otpcindia.in

**DISASTER MANAGEMENT - LIST OF CONTACT DETAILS OF NODAL OFFICERS/SECOND IN COMMAND UPDATED
ON 05/03/2019**

Region/SLDC	Name	Designation	Tel. Nos.	Mobile No.	Fax No.	E-mail Address
NERPC						
Nodal Officer	B. Lyngkhoi	Director/SE		9436163419		b_lyngkhoi@yahoo.com
Second in Command	S. Mukherjee	AD-I/AEE		8794277306		nerpc@ymail.com

SEM INSTALLATION PRIORITY LIST		
SL NO	FEEDER NAME	METER TO BE REPLACED/INSTALLED
1	SRIKONA END OF 132kV SILCHAR FDR -1	8562
2	SRIKONA END OF 132kV SILCHAR FDR -2	8668
3	DEOMALI END OF 220 KV KATHALGURI FEEDER	4206
4	MOKOK(S) END OF MOKOK-MOKOK-1	4517
5	MOKOK(S) END OF MOKOK-MOKOK-2	4511
6	KHUPI END OF 132 KV BALIPARA	
7	LEKHI END OF 132 KV NIRJULI	
8	LEKHI END OF 132 KV PARE	8372
9	KHUPI END OF 132 KV KAMENG	
10	ZUANGTUI END OF MELRIAT	
11	LUANGMOL END OF AIZAWL	
12	BYRNIHAT END OF MISA-I	6856
13	NTPC END CHECK METER	9708
14	NIRJULI ICT-1	5825
15	NIRJULI ICT-2	5824
16	NIRJULI END OF 132 KV LEKHI	6031
17	NIRJULI END OF 132 KV GOHPUR	5771
18	RANGIA END OF MOTONGA	8368
19	MOTONGA END OF RANGIA	8380
20	TINSUKIA END OF KATHALGURI CKT-1	8383
21	TINSUKIA END OF KATHALGURI CKT-2	8386
22	IMPHAL(S) END OF IMPHAL(PG) CKT-1	6950
23	IMPHAL(S) END OF IMPHAL(PG) CKT-2	8374
24	SAMAGURI END OF MISA CKT-1	5797
25	SAMAGURI END OF MISA CKT-2	5796
26	BTPS END OF NTPC CKT-1	5318
27	NINGTHOUKONG END OF LOKTAK	8375

Non-receipt of SEM Time Drift Report

SL.NO	PGCIL	STATUS
1	BNC (PG)	REPORT NOT RECEIVED
2	BADARPUR (PG)	REPORT NOT RECEIVED
3	Balipara(PG)	REPORT NOT RECEIVED
4	Silchar(PG)	REPORT NOT RECEIVED
5	MARIANI (PG)	REPORT NOT RECEIVED
6	HAFLONG (PG)	REPORT NOT RECEIVED
7	NIRJULI (PG)	REPORT NOT RECEIVED
8	Mokokchang(PG)	REPORT NOT RECEIVED
9	Khliehriat(PG)	REPORT NOT RECEIVED
10	SALAKATI (PG)	REPORT NOT RECEIVED
11	RANGIA (PG)	REPORT NOT RECEIVED
12	MISA (PG)	IRREGULAR
	ASSAM	
13	AZARA	IRREGULAR
14	DULLA VCHERRA	REPORT NOT RECEIVED
15	SARUSAJAI	REPORT NOT RECEIVED
16	TINSHUKIA	REPORT NOT RECEIVED
17	NAGALAND(S)	REPORT NOT RECEIVED
18	MIZORAM(S)	REPORT NOT RECEIVED
	TRIPURA	
19	UDAIPUR	REPORT NOT RECEIVED
20	P.K BARI	REPORT NOT RECEIVED
21	79 TILLA	IRREGULAR
	MANIPUR	
22	NINGTHOKONG	REPORT NOT RECEIVED
23	RENGPANG	REPORT NOT RECEIVED
24	KARONG	REPORT NOT RECEIVED
25	YUREMBAM	REPORT NOT RECEIVED
	MEGHALAYA	
26	UMTRU	REPORT NOT RECEIVED
27	BYRNIHAT	REPORT NOT RECEIVED
	ARUNACHAL PRADESH	
28	CHIMPU	REPORT NOT RECEIVED

पावर सिस्टम ऑपरेशन कारपोरेशन लिमिटेड
 (भारत सरकार का उद्यम)
 POWER SYSTEM OPERATION CORPORATION LIMITED
 (A Government of India Enterprise)



उत्तर पूर्वी क्षेत्रीय भार ब्रेपण केंद्र : लोअर नोंग्राह, लापालांग, शिलांग - 793 006, (मेघालय)
 North Eastern Regional Load Despatch Centre : Lower Nongrah , Lapalang, Shillong - 793 006, (Meghalaya)
 Ph : 0364 2537470, 2537427, fax - 2537486 Website : www.nerldc.org, Email- nerldc@posoco.in, CIN : U40105DL2009GOI188682

सन्दर्भ : उपक्षेत्राधिकार/एम.ओ/107/

दिनांक/ Date: 08/03/2019

सेवा में/To ,

General Manager (AM),
 NERTS, POWERGRID
 SHILLONG.

विषय/Sub: Pilot Project on 05-Minute Metering as per CERC Order dated 16/07/18

महोदय/Sir,

This has reference to CERC order dated 16/07/2018 on – “Pilot Project on 05-Minute Scheduling, Metering, Accounting and Settlement for Thermal/Hydro, and on Hydro as Fast Response Ancillary Services (FRAS) “. The key takeaways from the Order are as below –

- i. As a pilot, 5-minute metering can be in parallel with 15-minute metering.
- ii. All future procurements of Interface Energy Meters should ideally have recording at 5min interval and frequency resolution of 0.01 Hz. They should be capable of recording Voltage and Reactive Energy at every 5-min and should have feature of auto-time synchronization through GPS.
- iii. CTU shall facilitate the pilot project with installation of 5-minute meters at the pre-identified locations.

The technical specification of the meters will be as approved in the 34thTCC/WRPC meeting held on 27-28 July 2017. Tendering activity is in advanced stage in WRTS for replacing entire fleet of 15-Minute Meters in WR.

In view of above you are requested to initiate necessary action for arranging 16 no. of 5-minute SEMs along with 2 compatible DCDs for installation at NTPC-BgTPP and NHPC-Loktak.

भवदीय / Yours Sincerely,

(वी. सुरेश / V. Suresh)

मु.महाप्रबंधक / Ch. General Manager

Copy to:

1) Member Secretary, NERPC, Dong Parmaw, Lapalang, Shillong - 793006 (Meghalaya)

पंजीकृत कार्यालय : बी-9, कुतब इंस्टीट्यूशनल एरिया, कटवारिया सराय, नई दिल्ली - 110016, दूरभाष : 011-26560121, फेक्स : 26560039
 Registered Office : B -9, Qutab Institutional Area, Katwaria Sarai , New Delhi - 110016, Tel : 26560121, Fax : 011-26560039