



North Eastern Regional Power Committee

Agenda

For

46th Commercial Sub-Committee Meeting

CONFIRMATION OF MINUTES

1. CONFIRMATION OF MINUTES OF THE 45th COMMERCIAL SUB-COMMITTEE MEETING OF NERPC.

Minutes of the 45th CC Meeting held on 28th June 2022 at Hotel Classic Grande, Imphal, Manipur was circulated vide no. No.: NERPC/COM/CC_Min/2018/1842-1885 dated 15th July 2022.

No observations have been received from constituents. The minutes of the 45th CCM may be confirmed.

ITEMS FOR DISCUSSION

2 AGENDA ITEMS FROM NERPC

2.1 *Recent MoP/CERC Regulations*

The following MoP/CERC regulations/drafts are under consideration:

1. Draft Electricity (Amendment) Rules, 2022.
2. Implementation of the "Electricity (Late Payment Surcharge & related matters) Rules, 2022.
3. Draft Central Electricity Regulatory Commission (Indian Electricity Grid Code) Regulations, 2022.
4. Draft Central Electricity Regulatory Commission (Terms and Conditions of Tariff) (Third Amendment) Regulations, 2022.

This is for kind information of the members.

2.2 *National Level Optimization of Surplus Generation Capacity*

The generating capacities are not being optimally utilized on many occasions. The capacity is available in the country but due to one-to-one agreement constraint,

the generating capacity even though available cannot be utilized by the entity who due to some reason or the other is facing crisis. In order to have national level optimization, CEA has proposed to have a national level mechanism and portal so that any state/ discom can use the surplus power from central generating stations of any region. The draft proposal is attached as **Annexure 2.2** for information and further needful.

It is requested that the inputs/comments on the subject Draft Proposal be forwarded to the Grid Management (GM) Division of CEA preferably before 30th September, 2022.

Sub-committee may please deliberate.

2.3 Banking Arrangement within NER

Load-generation patterns of one state may complement the other states. Presently, surplus/deficit power is being sold/bought in RTM; however, option of banking between the states may also be explored. CEA convened a meeting on 18.8.2022 to map the surplus/deficit period/quantum of states and their existing banking arrangement, which is provided in the **Annexure 2.3**.

To further explore the possibility of banking within NER, following trend has been observed from the data of states' participation in short term/collective transactions for FY 2021-22.

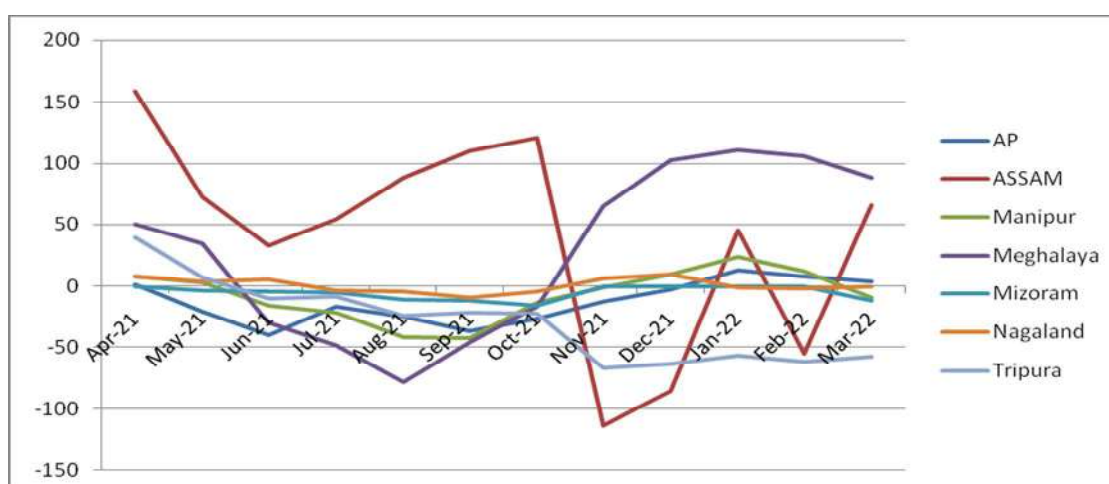

(+ means Market Purchase; - means Market Sell in MW)

Sub-committee may please deliberate.

2.4 Matters referred from OCCM

2.4.1 Proposed Deemed grant of GNA in line with CERC (Connectivity and General Network Access to the ISTS) Regulations, 2022 (Agenda from CTUIL)

As per Regulation 18.1(d) of CERC (Connectivity and General Network Access to the inter-State Transmission System) Regulations, 2022 notification dated 19-07-2022, CTU as a Nodal Agency has to bi-furcate the Deemed GNA Quantum of STUs (as provided in **Annexure-2.4.1**) within 30 days of notification of these regulations into two parts as:

- (i) GNA within the region
- (ii) GNA from outside the region.

This bifurcation has to be in proportion to contracts, within the region or outside the region, under Long Term Access and Medium-term Open Access obtained in terms of Connectivity Regulation, 2009.

In this context CTU has prepared the bifurcation of Deemed GNA quantum of states and other entities within and outside the region based on LTA/MTOA contracts/CGS power allocation for the billing month Jul'22 under CERC Sharing regulation 2020.

In the 193rd OCC the forum had requested the states to analyse their respective GNA quantum and its bifurcation and revert with feedback to CTU at the earliest. Also, it was stated that any need of further clarification and discussion would be looked into and might be undertaken in the next OCC meeting.

In 194th OCCM the forum decided to refer the matter to the upcoming CCM.

Sub-committee may please deliberate.

2.4.2 Fixed and energy charges of ISGS (Agenda from TSECL)

Fixed and energy charges of ISGS is required to be published every month. In 194th OCCM the forum decided to refer the matter to the upcoming CCM.

Sub-committee may please deliberate.

2.4.3 Reconstruction of Residential and Non-Residential Building at various stations of NERTS due to very dilapidated/non-livable condition (Agenda from NERTS)

Residential and Non-Residential buildings were constructed at Haflong, Jiribam, Aizawl, Kumarghat, Salakati, Misa, Dimapur&Imphal under Additional Transmission for GohpurItanagar (ATGI), Chukkha project, Transmission System associated with Doyang HEP (Combined Element) and Transmission system associated with Loktak HEP respectively. These buildings were constructed in year starting from 1983 and have completed around 28-39 years.

It is observed that due to ageing, these buildings have developed cracks and deteriorated and are not in liveable condition. In order to ascertain Structural Strength of these buildings, Structural Assessment of Residential & Non-residential buildings was carried out at Salakati, Haflong, Jiribam, Aizwal and Kumarghat through third party e.g. Bineswar Brahma Engineering College, Assam (Govt. institute AICTE approved).

Based on their assessment, it is found that the structures are quite unsafe and not in liveable condition. Further, it is mentioned that renovation may also not lead to any improvement in the strength of the buildings. In view of safety and security of employees (which are also a part of the system), it is not advisable to use these buildings for residential/non-residential use.

As manpower deployed in substations is an integral part of the system and since round the clock availability of manpower is essential for smooth O&M of these important Sub-stations, it is prudent that the residential/non-residential buildings are to be reconstructed as per present requirement.

Accordingly, as per present requirements, it is proposed for demolition and reconstruction of 16 nos quarters at Haflong, Jiribam, Aizawl&Kumarghat, 08 nos quarters at Salakati substation, 20 nos. Residential quarters at Misa, Dimapur and Imphal Substation under O&M ADDCAP 2019-24 tariff block. Moreover, 1 no Transit camp, and Admin building each at Haflong, Jiribam, Aizawl, Kumarghat, Dimapur and Imphal substation are also needs to be demolished and reconstructed under ADDCAP.

Accordingly, it is proposed for construction/demolition of buildings as per following details:

Name of Substation	Const. Year	No of Quarters to be demolished	Nos of quarters to be Constructed	Estimated Cost (₹ In Cr.)
ATGI Project				
Haflong	1987	16	16	4.36
Jiribam	1985	16	16	4.52
Aizawl	1988	16	16	4.21
Kumarghat	1989	16	16	4.38
Transmission System associated with Doyang HEP				
Misa	1994	20	20	5.48
Dimapur	1995	20	20	5.48
Transmission system associated with Loktak HEP				
Imphal	1983	20	20	5.48
Chukkha TS				
Salakati	1987	08	08	2.12

Name of Substation	Year	No of Non Residential Building to be demolished	Nos of Non Residential Building to be Constructed	Estimated Cost (₹ In Cr.)
ATGI Project				
Haflong	1987	1 each	1 each	1.4 Cr
Jiribam	1985	1 each	1 each	1.4 Cr
Aizawl	1988	1 each	1 each	1.4 Cr
Kumarghat	1989	1 each	1 each	1.4 Cr
Transmission System associated with Doyang HEP				
Dimapur	1996	1 each	1 each	1.4 Cr
Transmission system associated with Loktak HEP				
Imphal	1983	1 each	1 each	1.4 Cr

** Non-Residential Building – 1 no Transit camp, and Admin building each

Estimated Cost for Demolition/Reconstruction for Residential & Non-Residential buildings under

- a) ATGI project: ₹ 23.07 Crs
- b) Transmission System associated with Doyang HEP project: ₹12.36 Cr
- c) Transmission system associated with Loktak HEP project: ₹ 6.88 Crs
- d) Chukkha TS: ₹ 2.12 Crs

The agenda has been taken up in 45th CCM meeting wherein it was discussed that issue may be put up in OCC meeting. Accordingly, the agenda item has been taken up in 192nd OCC meeting wherein it has been finalized that discussion shall be held with counterparts in other region and the forum shall be updated accordingly.

In view of above, it is requested to kindly accord consent for construction of new residential/non-residential buildings after demolition of existing ones at a financial implication as mentioned above in the respective stations/projects.

After detailed deliberation the forum referred the matter to CCM for thorough discussion.

Sub-committee may please deliberate.

3. AGENDA ITEMS FROM ASSAM

3.1 *Agenda by APDCL: Bill raised to Arunachal Pradesh for Settlement of meter reading of 11 KV Rowing feeder and for transmission charge for power supply to Arunachal Pradesh through 33KV/11KV lines of Assam*

As per the minutes of 36th and 37th CCC meeting of NERPC, NERPC certified the transmission charges to be paid by Arunachal Pradesh to APDCL, Assam for power supply to Arunachal Pradesh through 33KV/ 11KV lines of Assam for the period of FY 2020-21. Accordingly, APDCL raised a bill to DoP, GoAP on 29.7.2022 for ₹ 2,23,82,165.00.

As such, this is for deliberation of the forum with a request to the DoP, Govt of Arunachal Pradesh for the early settlement of the dues.

Sub-committee may please deliberate.

3.2 *Agenda by SLDC Assam*

North East Frontier Railway has availed Long Term Open Access to evacuate power from its captive power plant BRBCL located in the state of Bihar. North East Frontier Railway has been allotted 5 MW as a share from its captive power plant. Since Railway has taken Long Term Open Access, it is a query of SLDC, Assam as whether Railway will be treated as a DIC like APDCL for the state of Assam or will

it be treated as a state entity. Furthermore, if it is to be treated as a state entity, then how the applicable PoC in case of Railway will be taken care of.

Sub-committee may please deliberate.

4. AGENDA ITEMS FROM TSECL

4.1 *Surrender of Power purchase by Manipur from Baramura GTP unit IV and V*

TSECL was exporting power to Manipur from Baramura Gas Thermal Power station as per bulk power supply agreement. As on date, outstanding with Manipur is around ₹ 41 Cr. including the late payment Surcharge (LPSC). On 27/05/2022 Managing Director, MSPDCL, Manipur vide letter no 2/29/2018/MSPDCL(comm1)/2030-33 dt 27/05/22 informed MD, TSECL that Manipur is Surrender Baramura Power from 1st June,2022 onwards due to tariff revision from ₹ 3.01/kwh to ₹ 4.43/kwh. Presently exploring power to Manipur is discontinued.

The matter was also discussed in the last CC meeting. In the last CC meeting, Manipur has agreed to payment. TSECL has received around ₹ 8.0 Cr on 05/09/2022. Hence it is requested kindly to confirm the payment mechanism.

Sub-committee may please deliberate.

4.2 *Outstanding Dues of Mizoram*

As on date, an amount of ₹ 12.0 crores is outstanding excluding the surcharge with Mizoram. It is to mention that TSECL is to make timely payment to Gail/ONGC regularly to avoid surcharge etc as well as to avoid regulation of Gas supply. Therefore, Mizoram is requested to ensure monthly payment to avail rebate as well as to avoid surcharge, regulation of power supply etc.

LC of Mizoram is expiring on 10th October,2022. Request Mizoram to renewal of LC in time.

Sub-committee may please deliberate.

4.3 *Allocation of merchant power from OTPC*

TSECL is facing power shortage during any outage of ISGS generation as well as state generation. Presuming that in outage scenario, TSECL has communicated to

OTPC for allocated their Merchant power. In the commercial forum the matter was discussed so many times. Hence, NERPC is requested kindly to look into the matter so that TSECL can enjoy the merchant power on long term basis as an early date.

Sub-committee may please deliberate.

4.4 Rescheduling of power from BgTPP

After reallocating of BGTPP power to Tamilnadu, TSECL is facing huge shortage of power specially during any outage of ISGS or state Generation. The background of power surrender from BGTPP was high cost around ₹ 6.50/kwh in the year 2016. On that scenario TSECL has communicated to Ministry of Power for surrender. Presently the tariff of BGTPP has reduced to ₹ 5.60 approx after various consultations with the beneficiaries. Before reallocating BGTPP power to Tamilnadu, TSECL was totally unaware - no discussion/communication from MOP or NERPC/NERLDC.

In view of above scenario, TSECL is requested kindly to reschedule the BGTPP share to TSECL.

Sub-committee may please deliberate.

4.5 Calibration of SEM meters (Bangladesh drawal) at Suryamani Nagar S/S

Collecting meter data for Bangladesh drawal from Suryamani Nagar S/S through vin plus software since March, 2016. On that basis bill raised by TSECL. The quantum of energy is also reflecting in the REA. Hence Calibration may be required in presence of Bangladesh officials. PGCIL is requested to take the necessary steps for calibration.

Sub-committee may please deliberate.

4.6 General Network Access (GNA) for Tripura

General Network Access (GNA) will be implemented very shortly. It has seen GNA for Tripura is 311MW based on the last three years average data. It is to mention that last three years average data consisting of Bangladesh drawal. Impact of GNA

in the region is requested to discuss in the meeting. Earlier in POC regime, TSECL was paying around 3 Crores, but presently paying 11 to 12 crores.

Sub-committee may please deliberate.

5. AGENDA ITEMS FROM NEEPCO

5.1 *Outstanding dues of beneficiaries payable to NEEPCO as of 21.09.2022 are as follows:*

(in crores INR)

State	Principal dues (>45 days)	Late Payment Surcharge (LPS) Due	Total Due (Principal + LPS)	The current amount is yet to be due (< 45 days)
1	2	3	4=2+3	5
APDCL, Assam	0	0	0.00	109.87
P&E Deptt, Mizoram	0.33	0	0.33	50.71
MSPDCL, Manipur	21.38	0	21.38	43.78
TSECL, Tripura.	103.68	0	103.68	90.43
DoP, Ar. Pradesh.	0	0	0	0
DoP, Nagaland.	0	0	0	13.61
MePDCL, Meghalaya.	0	0	0	30.05
CSPDCL, Chhattisgarh	0	0	0	3.66
HPPC, Haryana	0	0	0	3.66
UPPCL, Uttar Pradesh	1.49	0	1.49	0
Total	126.88	0.00	126.88	345.77

The above statement reflects an alarming situation. Yet, it has to be appreciated that some states are paying regularly and some are trying hard to clear the dues.

Due to the accrual of such outstanding dues, NEEPCO is facing difficulty to meet its day-to-day expenditure including fuel costs required for operating its thermal power stations. In the interest of extending better service to its beneficiaries, NEEPCO earnestly requests all the beneficiaries to make the payment on a regular basis.

Sub-committee may please deliberate.

5.2 Strengthening of evacuation system of Pare HEP of NEEPCO and capitalization of the expenditure to be incurred for it the implementation of the scheme:

The above Agenda was discussed in the 192nd OCC Meeting, dated 21.07.2022 and as per the MoM, all beneficiaries are requested to give their consent on the capitalization of expenditure to be incurred for the implementation of the scheme. The total financial involvement stands for the Strengthening of the evacuation system of Pare HEP (i.e., upgradation of LILO portion) stands at Rs. 4.31 Crores (inclusive of all taxes& duties) and the amount of the charges would be nominal on the beneficiaries for the span of 40 years.

The relevant para of the MOM of the 192nd of OCC Meeting is reproduced as follows:
DD, NERPC noted that as NEEPCO is a generating utility the transmission works undertaken by NEEPCO cannot be booked under Transmission Tariff and has to be shared by the beneficiaries of Pare HEP.

AGM (CommI), APDCL informed the forum that Final tariff of Pare HEP is yet to be approved by Hon'ble CERC. He also informed that as part of the Tariff Petition Agreement of APDCL with NEEPCO dated 16.08.2021 was submitted to the Hon'ble CERC, in which NEEPCO and APDCL have agreed for tentative levelised tariff of ₹ 5.75/unit for 40 years with no escalation. However, he stated that APDCL is open to Reviewing the agreement and submit the same to Hon'ble CERC.

DoP Nagaland agreed with the view of APDCL. While other State utilities decided to await for directions of Hon'ble CERC in this regard.

The forum in principle agreed to the requirement of the above works and requested NEEPCO to go ahead with the work.

It was also decided that:

- (i) Assam and Nagaland would revise their agreements with NEEPCO and submit the same to Hon'ble CERC.
- (ii) NEEPCO would submit Supplementary copy to its Original Tariff Petition of Pare HEP to Hon'ble CERC.
- (iii) NEEPCO would place the agenda in the next CCM/RPC for approval.

Further to the above, the issue was also discussed in the **6th Standing Committee Meeting of NER** held at Imphal dated 03.10.2016 and following additional/ modification in the transmission system associated with Pare HEP was agreed as a part of NERSS-IX. (Agenda No. 6) – related pages are enclosed at **Annexure-5.2A**.

- a. Bypassing of LILO of Ranganadi - Naharlagun / Nirjuli at Pare HEP so as to form direct Ranganadi - Naharlagun / Nirjuli 132 kV S/C line – ISTS by NEEPCO.
- b. Pare HEP (from LILO point) – North Lakhimpur (AEGCL) 132kV D/c line (with ACSR Zebra conductor) along with 2 no. 132 kV line bays at North Lakhimpur – ISTS (implementation through TBCB/RTM to be decided by empowered committee).
- c. LILO of one circuit of Pare HEP – North Lakhimpur (AEGCL) 132kV D/c line (with ACSR Zebra) at Nirjuli substation – ISTS (implementation through TBCB/RTM to be decided by empowered committee).
- d. Re-conductoring of LILO portion at Pare end (of Ranganadi – Naharlagun / Nirjuli 132kV S/c line) with HTLS (HTLS equivalent to ACSR Zebra) along with modification of 132kV bay equipment at Pare HEP – ISTS by NEEPCO

Under 6.4 of the above items, Director, CEA stated that to recover additional investment in the transmission and bay equipment modification as suggested above, M/s NEEPCO may file revised tariff petition in CERC.

Out of above 4(four) scopes, b & c are being executed by M/s Sterlite Power Transmission Ltd as TBCB contractor.

For (a) & (d), Chairman and Managing Director of NEEPCO communicated with Chairperson, CEA on 05.11.2020 requesting the scopes allocated to NEEPCO may kindly be carried out through the TBCB contractor or the expenditure may be granted from PSDF/MoDONER as the same is under strengthening scheme. The letter is enclosed as **Annexure -5.2B**.

Subsequently, several meetings were held on the issue but CEA did not agree to the request (**Annexure- 5.2C & 5.2D**) and asked NEEPCO to execute the work as per modalities as discussed in the meeting dated 18.11.2021 (**Annexure-5.2E**).

The scheme of execution of work was discussed and approved in presence of CEA, NERPC and M/s Sterlite Power Transmission Ltd. in the meeting dated. 08.04.2022. (**Annexure-5.2F**).

Based on above, an offer was collected from M/s Sterlite Power Transmission Ltd. for both (a) & (d) scopes amounting to **Rs. 3,65,20,119.00** which is exclusive of F&I and taxes and duties. With GST, financial involvement stands at **Rs. 4,30,93,740.00 (Annexure-5.2G)**.

Since TBCB contractor is M/s Sterlite Power Transmission Ltd., it is prudent to execute the small portion of work which is entrusted to NEEPCO through the same executing agency otherwise there is every chance of mismatching of commissioning schedules of these three lines if a third party is engaged by NEEPCO. Moreover, longer outages of the three lines may also be required.

In view of the above and as per the decision of the 6th Standing Committee Meeting of NER and MoM of the 192nd OCC Meeting of NERPC and as suggested by CEA, the forum is requested their consent to recover the abovementioned additional investment in the transmission system at Pare HEP end as explained above.

Therefore, the above is placed for deliberation and decision in the house under the aegis and guidance of NERPC.

Sub-committee may please deliberate.

6. AGENDA ITEMS FROM NERLDC

6.1 *Deviation Pool Account outstanding:*

Status of Deviation charges outstanding as on 16/09/2022 is attached (**Annexure-6.1**).

Manipur is the major defaulter. Manipur – Net O/s Payable to Pool is ₹ 2.32 Crores [Deviation Principal, ₹ 1.44 Crores + Deviation Interest, ₹ 0.88 Crores].

Break-up of Deviation Interest of Manipur (in ₹)	
Wk-01 to Wk-26 of FY 20-21	4001350
Wk-27 to Wk-52 of FY 20-21	2736295
Wk-01 to Wk-25 of FY 21-22	263217
Wk-26 to Wk-51 of FY 21-22	1757223
Total	8758085

Clearance of O/s payable had been regularly followed up.

Manipur is requested to take immediate necessary action in this regard.

All the pool members are requested to clear outstanding payable due within the stipulated time to avoid late payment interest.

Sub-committee may please deliberate.

6.2 Reactive charges outstanding: -

Status of Reactive charges outstanding as on 16/09/2022 is attached (**Annexure-6.2**).

O/s Payable to Reactive Pool by Manipur - ₹ 7.53 Lakhs.

O/s Payable to Reactive Pool by Meghalaya - ₹ 66.09 Lakhs.

O/s Payable to Reactive Pool by Mizoram - ₹ 17.43 Lakhs.

Manipur, Meghalaya & Mizoram are required to take necessary action.

All the pool members are requested to clear outstanding payable due within the stipulated time to avoid late payment interest.

Sub-committee may please deliberate.

6.3 Signing of DSM & Reactive Reconciliation Statements: -

Status of signing of Reconciliation statements of DSM & Reactive as on 16/09/2022 is attached in **Annexure-6.3**

1. Pending DSM reconciliation with – Manipur (1 Quarter) & NHPC (1 Quarter).
2. Pending Reactive reconciliation with – Manipur (1 Quarter).

Manipur & NHPC are requested to sign the reconciliation statements as early as possible.

Sub-committee may please deliberate.

6.4 Opening of LC against Deviation Charges Liability: -

As per CERC (Deviation Settlement Mechanism and related matters) Regulations 2014, the LC amounts pertaining to NER entities are mentioned below (Refer Annexure-6.4): -

Constituents	LC to be opened in FY 22-23 ₹ (in Lakhs)	Present Status
Ar. Pradesh	242.48	LC of ₹ 182.36 Lakhs, valid till 31/03/2023, to be enhanced
Assam	318.99	LC of ₹ 203.29 Lakhs, valid till 01/12/2022, to be enhanced
Manipur	40.07	LC Not opened/Not intimated
Meghalaya	80.07	Sufficient amount retained in Pool
Mizoram	44.02	LC of ₹ 44.02 Lakhs, valid till 14/02/2023.
Nagaland	74.18	LC of ₹ 74.18 Lakhs, valid till 20/03/2023.
Tripura	205.57	LC of ₹ 144.00 Lakhs, valid till 18/11/2022, to be enhanced

It is requested to open/enhance LC to adhere to CERC stipulation.

Sub-committee may please deliberate.

6.5 Signing of RLDC Fee and Charges Reconciliation Statements: -

NERLDC Fee and Charges Reconciliation Statements for Q1 for FY 2022-23 was issued on 27/07/2022. We have received Signed/Reconciled copy from few users.

All remaining users are requested to send the signed Reconciliation Statements at the earliest.

Sub-committee may please deliberate.

6.6 Procurement of SEM & DCD/Laptop for future requirements: -

NERTS may intimate the status of procurement of Additional 40 nos. of DCD

In 192nd OCCM, CTU informed that order for 40 DCDs has been placed to PGCIL and shall be made available by Oct'22 and in case of emergency diversion from inventories in other regions can be done.

CTU had also given presentation on “Process of Procurement, Distribution and Installation of SEM/DCD along-with Billing mechanism and charges”. The forum requested all the DICs to submit comments regarding presentation of CTU latest by 31st July’2022.

In 193rd OCCM, after detailed deliberation the forum decided to discuss the matter in CCM.

Sub-committee may please deliberate.

7. AGENDA ITEMS FROM NERTS

7.1 *Outstanding dues:*

The total outstanding dues (pertaining to both PoC as well as non-PoC billing) payable by NER beneficiaries to CTUIL/POWERGRID as on **20.09.2022** is detailed below: -

(All Figures in ₹ Crores)

State/DIC	Outstanding dues > 45 days	Total Outstanding dues	Remarks
Arunachal Pradesh	0.02	8.44	<i>Approx. 01 month receivables</i>
APDCL, Assam	0.00	50.78	<i>Approx. 01 month receivables</i>
MSPDCL, Manipur	23.24	29.60	<i>Approx. 03 months receivables</i>
MSPCL, Manipur	0.61	0.71	<i>Approx. 06 months receivables</i>
MeECL, Meghalaya	5.00	11.43	<i>Approx. 02 months receivables</i>
Mizoram	23.02	27.28	<i>Approx. 3 months receivables & Bilateral bills</i>
Nagaland	0.00	6.89	<i>Approx. 01 month receivables</i>
TSECL, Tripura	0.00	10.01	<i>Approx. 01 month receivables</i>
NEEPCO	124.43	124.43	<i>Bilateral bills</i>

Concerned DICs with >45 days outstanding dues, viz. MSPDCL, Mizoram, MeECL, NEEPCO & MSPCL may be impressed upon to clear the outstanding dues immediately since POWERGRID and other transmission licensees (on behalf of whom CTUIL does the billing & collection) are facing financial constraints due to accumulation of such huge outstanding dues.

Sub-committee may please deliberate.

7.2 Status of LC of NER beneficiaries (as per new requirement):

As it is known to all concerned, Central Transmission Utility of India Ltd (CTUIL), a subsidiary of POWERGRID, has started functioning as CTU w.e.f. 01.04.2021 as per notification dated 09.03.2021 issued by MoP, GoI and accordingly, the Billing, Collection and Disbursement of transmission charges (*for PoC billing*), a function of CTU, is being undertaken by CTUIL with effect from **01.04.2021**.

Consequent to above, separate LCs in favour of CTUIL (*for PoC Billing*) and POWERGRID (*for non-PoC billing*) in place of existing LCs, which are in favour of POWERGRID, are to be maintained by DICs in line with provisions of Regulation 19 of CERC Sharing Regulations, 2020 and to avail CTUIL rebate scheme for FY 2022-23.

The status of LCs (*as per above new requirement*) of NER DICs as on **20.09.2022** is as follows: -

State/DIC	LC in favour of CTUIL (for PoC billing)	LC in favour of POWERGRID (for Non-PoC billing)
Arunachal Pradesh	Available (<i>Enhancement required</i>)	Not Available
APDCL	Available	Available
MSPDCL	Available (<i>Enhancement required</i>)	-
MSPCL	-	Not Available
MeECL	Available	Available
Mizoram	Available	Available
Nagaland	Available	Available
TSECL	Available	Available

Arunachal Pradesh and **Manipur** may be impressed upon to enhance their LCs to the requisite amounts.

Sub-committee may please deliberate.

8. AGENDA ITEMS FROM OTPC

8.1 *Outstanding Dues of OTPC against NER beneficiaries – OTPC:*

The current total outstanding dues of OTPC against the NER beneficiary states (as on 20-09-2022) are as under:

(Amount in ₹ Crores)

SI.No.	Beneficiary	Outstanding Dues (>45 Days)	Total Outstanding
1	Mizoram	10.80	17.17
2	Tripura	35.81	75.04
3	Manipur	2.13	12.24
	Total	48.74	104.45

The total outstanding dues of above states as on 20-09-2022 are ₹ 104.45 Crores out of which outstanding beyond 45 days is ₹ 48.74 Crores. Tripura, Manipur and Mizoram are requested to clear the outstanding dues over 45 days, at the earliest. The forum is also requested to impress the urgency of the liquidation of dues in view of MoP guidelines for encashment of LC/Regulation of power and non-scheduling of power by RLDC.

Sub-committee may please deliberate.

ANY OTHER ITEMS

9.1 *Category wise hourly load data requirement for the last 5 years for different States.*

India has announced a target to achieve net zero emissions by the year 2070. In this context, CEA, Ministry of Power in collaboration with Danish Energy Agency (DEA) under Indo-Denmark Partnership program, is carrying out generation expansion planning studies which will focus on Power Sector Development in India for a horizon of up to 2050. The planning studies are underway for which extensive data inputs are required.

In this regard, CEA has requested from all the respective State Discoms and SLDCs to furnish historical demand/load data on hourly basis for different consumer categories viz. Domestic, Industrial, Commercial, Agriculture,

etc. for the last 5 years (ie, 2017-18 to 2021-22) in order to carry out the above studies effectively.

It is therefore requested that the data pertaining to the following may kindly be furnished in respect of your State Discoms/SLDCs:

(1) Historical demand/load data on hourly basis for different consumer categories viz. Domestic, Industrial, Commercial, Agriculture, etc. for the last 5 years (ie, 2017-18 to 2021-22) (whatever is available)

(2) Plans for shifting agricultural load to solar hours.

(3) Views of SLDCs/Discoms on future load patterns.

A format for furnishing above information is given at **Annexure-9.1**

Kindly furnish as per the attached format and mail to: nerpc.commercial@gov.in by 30th September 2022.

DATE AND VENUE OF NEXT COMMERCIAL COMMITTEE MEETING
--

The next Commercial Coordination Sub-Committee meeting will be held in the month of December 2022. The date and venue will be intimated separately.

National level optimization of Surplus generation capacity

- (A) Background
1. The generation capacity in the country are mainly categorized as under:
 - (i) State owned generating capacity
 - (ii) Central Generating Stations
 - (iii) Private Sector: IPPs
 - (iv) Captive generating Stations
 2. The generating capacities are not being optimally utilized on many occasions. Every year we observe difficulty in meeting the demand and some states do resort to power cuts. Especially during the April, May, September and October months the crisis is observed. The capacity is available in the country but due to one to one agreement constraint, the generating capacity even though available cannot be utilized by the entity who due to some reason or the other is facing crisis.
 3. The Distribution licensees tie up power from above generating sources mainly under following routes:
 - (i) At regulated tariff determined by the Appropriate Commission under section 62 of the EA 2003.
 - (ii) At bid tariff adopted by the Appropriate Commission under section 63 of the EA 2003.
 - (iii) Banking of Power
 4. State owned generating companies supply power to Distribution companies of the same State and also supply seasonal surpluses to some other states under banking arrangements among such distribution companies.
 5. Central Generating companies supply power to the States under the allocation made by the Central Government. There are some power which have been surrendered by the States are also reallocated to the other needy States. Some States have exited from the PPA after completion of 25 years, and such power is available for merchant sale as well.
 6. The allocation of power is generally done to the states within the regions. There are five regions in the country ie Eastern, Western, Southern, Northern and North Eastern regions. Accordingly, the scheduling is also done among the beneficiaries of the region or the Power Purchase Agreement (PPA) holders from such power plant. In case there is Un-requisitioned Surplus (URS) power within the region, it is available to only the original beneficiary of that power plant which means such URS power remains concentrated in the respective region only. There are following concerns:
 - (i) Generally there are similar demand pattern in the region and hence if demand is low, then some of the generating stations in the merit order despatch has surplus capacity as they are not scheduled. As a result, most

of the time, due to overall requisition being less than technical minimum (TM), the plant(s) donot generate and go under Reserve Shut Down (RSD). There are two consequences of this:

- a. The plant is out of bar and is not available in the grid. Hence they cannot serve the grid under any contingencies or be used for Ancillary Services (Reserves).
 - b. Even the states who has power allocation and need power from such plant are deprived of the generation, as due to not attaining the TM, the plant is not generating and remains under reserve shutdown.
- (ii) The demand in some other region may be high or the states who donot have the allocation from such power plants may be needing the power due to increased demand. Eg. Peak in Northern region is during summerwhereas Peak in Southern region is during winter. Similarly there is diversity in the time at which the peak occurs in the States.

7. At present, to facilitate use of surplus power by the constituents of the region, a portal is operational in Western Region (WR) and Eastern Region (ER). In order to have national level optimization, it is being proposed to have a national level mechanism and portal so that any state/ discom can use the surplus power from central generating stations of any region.

8. Private Sector: IPPs

Besides PPA holders, they may sell their surplus power in the power exchanges or sell in Term Ahead Market (TAM) or Day Ahead Market (DAM) or Real Time Market (RTM) or through DEEP e-portal.

9. Captive generating Stations

They can sell their surplus power after meeting their own requirement.

(B) Proposed Scheme

1. For Central Generating Station (CGS).

- a. Flexibility to use of URS power (Day ahead basis) by all constituents in the country and ;
- b. Use of longer duration surplus power.

2. For Inter- State Generating Stations (ISGS) (excluding CGS)

3. For Surplus power with the States/ Distribution companies (whether State owned or Private)

The above proposal can be implemented in phases:

Phase -1 : for CGS – within 3 months

Phase -2 : For ISGS (excluding CGS) – within 6 months

Phase -3 : For Surplus power with the States/ Distribution companies (whether State owned or Private) by other States/ Distribution companies– within 6 months

1.1 Phase 1: Standard operating Procedure (SOP) for flexibility to use the URS power of CGS by all the States/ Discoms irrespective of the original beneficiary/ beneficiary of the region

1. The original beneficiaries of CGS shall submit through web-based energy scheduling portal the surrendered quantum/URS (MW), duration (block-wise) and tariff (determined by the Appropriate Commission). However, the tariff will be subject to any changes made by the Appropriate Commission.

In case of URS offer is for longer duration, the original beneficiaries may also provide a standing consent to the CGS specifying quantum and time period.

2. The willing new beneficiaries shall submit its requisition for availing URS power through web-based energy scheduling portal. The quantum and time period shall be specified and acceptance to pay the tariff as determined by the Appropriate Commission.
3. CGS shall be permitted to revise its schedule for URS power from its original beneficiary to any other beneficiary. The new beneficiary shall be liable to pay both variable charge (VC) and fixed cost (FC) for full requisition and original beneficiaries shall have no right to recall as entire FC liability is shifted to the new buyer.
4. The payment shall be secured through suitable payment security mechanism e.g. letter of credit (LC) or advance payment or any other mutually agreed payment security mechanism.
5. Consent and details of surrender and requisition of URS power of the original beneficiaries and the new beneficiaries shall be submitted by CGS to the National Power Committee (NPC) through portal.
6. NPC shall provisionally allocate URS power on portal to willing new beneficiaries based on following criteria:
 - i. First preference shall be given to co-beneficiaries of the CGS.
 - ii. In case multiple beneficiaries seek to avail URS power from a CGS, the URS power allocation will be on first come first serve basis.

- iii. In case, multiple beneficiaries request simultaneously (in the same time block) and the sum of their requisitioned power exceeds the available URS power, then the URS shall be apportioned & scheduled prorata in the ratio of the respective requisitions (in MW) made by the buyers.
7. NPC shall communicate through portal the provisional allocation of URS power to the CGS, respective RLDCs and NLDC and the beneficiary to whom the power is temporarily allocated.
 8. NLDC shall finalize on the portal the allocation of URS power after checking availability of margins in the transmission network, and communicate to ISGS, respective RLDCs and NPC.
 9. The concerned RLDC shall schedule the URS power as per the requisition within the time blocks stipulated in IEGC.
 10. Payment settlement will be as per the REAs (Regional Energy Accounts) prepared by the concerned RPCs. This will be binding on all the buyers of power from CGS.
 11. The procedure of temporary allocation of power from CGS can be further simplified as under:
 - i. Temporary allocation of 1 to 15 and 16 to end of month shall be done by CEA with the following time lines:

Time Line	Beneficiaries actions	Advantage
D-15 to D-13 day	Surplus beneficiaries would upload the surrender information in portal	The buyer/purchaser would be assured of its power. The seller will be relieved of FC.
D-12 to D-10	Requisitioning Beneficiaries will show their interest	
Request received upto 24 hrs of D-10 would be frozen		
D-9 to D-8	PSM by beneficiaries and confirmation by the generating stations	
D-7 to D-5	CEA would compute the temporary allocation.	
D-4	CEA would be issue the temporary allocation which would be implemented in WBES of RLDC.	

Note: For 1st October to 15th October window for surrender will open during from 16th September to 18th September. Requisitioning window will open from 19th September to 21st September and on 27th September CEA will bring out temporary allocation.

- ii. Generally to facilitate revival of units under Shut Down (Max around 36 hrs for cold start) or to avoid units to for RSD, on every D-2, RLDC would take the surrender and purchase request received upto 24 hrs of D-3 for the ISGS it is scheduling and compute share allocation which will be used for creating Entitlement, scheduling and part load compensation for complete D day (00-24 hrs). The requisition can be beyond the MoP allocation. The same would be published by RLDC on its website by 18 hrs on D-2 day. This would address short term requirement on assured power/surrender on D-2.
- iii. If any unit goes on RSD, respective RLDC would create on bar entitlement based on requisitions which will be used for creating On bar Entitlement, scheduling and for computing part load compensation. Requisitions can be beyond MoP allocation. This would be computed by RLDC for each day on rolling basis. Off bar Entitlement will be created based on surrender request. This will ensure power to needy states and not only FC liability for units going under RSD. Small states will get their share from On Bar units. Part Load compensation will be paid only on whose name Entitlement is created.

1.2 Phase 2: Standard operating Procedure (SOP) for flexibility to use the URS power of ISGS (other than CGS) by all the States/ Discoms irrespective of the original beneficiaries of the region

Similar procedure may be adopted for such plants as well.

In case of these power stations, as there is no allocations made by the Central Government, the proposal concerning allocation, as stated in para 1.1, may not be applicable. Rest of proposal may be adopted. If both the buyers and the seller agree and give consent, the surplus power from such stations can also be used by other buyers. In such cases the new buyer will pay the full fixed cost and the variable charges.

1.3 Phase -3 : Standard operating Procedure (SOP) for flexibility to use the Surplus power with the States/ Distribution companies (whether State owned or Private) by the other States/ Discoms

- i) At present some of the distribution companies are giving the surplus power to some other states through the banking process and take back the power when they need it as per the mutual agreement.
- ii) It is also observed that due to the diverse nature of demand in different states at different time, there is a possibility of optimum utilization of resources.

- iii) Many times it is seen that the States which are surplus during some period of time are keeping their own generating stations under reserve Shutdown. But there are other states which are facing crisis. But in the absence of any mechanism, the resources even though available in the country but is not used to meet the overall demand in the country and there are load shedding. In the mutual interest, the mechanism needs to be established which helps the needy states. The State generating companies can also improve their plant load Factor and the effective overall per unit cost of generation of such generating companies can also be reduced.
- iv) An exercise was carried out by the RPCs to know the states which are having surplus power and its duration. The states who can utilize such power were also identified. There are complementarity of demand. This can also vary depending upon the actual case even for a smaller duration depending upon the weather condition.
- v) However, this cannot be one time exercise, the best use can be if there is an online mechanism where in states can temporarily transact.
- vi) There may be an argument that the states can go and sell power in the power exchanges. But the experience shows that the states prefer to keep their units under reserve shutdown. Further, the states / state owned generating companies do not take risk to bring their units mainly due to uncertainty of the Market clearing price.
- vii) Thus, if the tariff is assured by some other states, the generating stations will come on bar and generate power. This will also reduce the burden of fixed cost to the Discoms and the retail tariff will also reduce benefitting the consumers. The buying State/ discoms shall also bear the transmission charges as applicable.
- viii) In view of the above following is proposed :
 - a. Banking arrangements may continue as at present
 - b. Even for shorter duration, states may trade at the tariff determined by the Appropriate Commission. State generating companies will also become viable as their PLF will increase. Thus reducing the per unit cost of power to even the existing buyers/ distribution companies.

- (C) The summary proposed timelines for implementation to prepare to avert future power crisis at the earliest.
- a. The present web based energy scheduling online portal to be upgraded by NTPC at the national level in 2 months
 - b. POSOCO to link it with the scheduling module.
 - c. The phase – I for CGS to be completed by 30th November 2022.
 - d. States to give their comments in 20 days. Their suggestions to be incorporated by 15th October 2022.
 - e. The phase – II and Phase – III to be completed by February 2023.

- f. This will ensure capacity availability for all the States/ Discoms especially during the April, May, September and October months when the crisis is observed.

ANNEX 2.3

State	Month	Jan	Jan	Feb	Feb	Mar	Mar	Apr	Apr	May	May	Jun	Jun	Jul
	Hrs	Solar hrs.	Non Solar hrs.	Solar hrs.	Non Solar hrs.	Solar hrs.	Non Solar hrs.	Solar hrs.	Non Solar hrs.	Solar hrs.	Non Solar hrs.	Solar hrs.	Non Solar hrs.	Solar hrs.
Assam	Surplus	100-500		100-500		100-500								
Assam	Deficit							600-700*	600-700*	600-700*	600-700*	600-700*	600-700*	600-700*
Meghalaya	Surplus									120	120	120	120	120
Meghalaya	Deficit	100	100	100	100	100	100							
Manipur	Surplus											55^	55^	55^
Manipur	Deficit	40	40	40	40									
Tripura	Surplus													
Tripura	Deficit	v	v	v	v	v	v	v	v	v	v	v	v	v
Arunachal	Surplus											65	65	65
Arunachal	Deficit	30	30	30	30	30								
Nagaland	Surplus									30	30	30	30	30
Nagaland	Deficit	40	40	40	40	40	40							
Mizoram	Surplus													40
Mizoram	Deficit	peak	peak	peak	peak	peak	peak	peak	peak	peak	peak	peak	peak	

v quantum to be submitted by states

v/2 mid of month

* peak hours

^ off-peak hours

State	Jul	Aug	Aug	Sep	Sep	Oct	Oct	Nov	Nov	Dec	Dec	Existing Banking
	Non Solar hrs.	Solar hrs.	Non Solar hrs.	Solar hrs.	Non Solar hrs.	Solar hrs.	Non Solar hrs.	Solar hrs.	Non Solar hrs.	Solar hrs.	Non Solar hrs.	
Assam								100-500		100-500		
Assam	600-700*	600-700*	600-700*	600-700*	600-700*							
Meghalaya	120	120	120	120	120							Haryana, BYPL
Meghalaya								100	100	100	100	
Manipur	55^	55^	55^									BYPL through M/s Kreate
Manipur										40	40	
Tripura												
Tripura	v	v	v	v	v	v	v	v	v	v	v	
Arunachal	65	65	65									Bilateral trade with APPCL
Arunachal										30	30	
Nagaland	30	30	30	v/2(30)	v/2(30)							Goa, Haryana, UP, HP
Nagaland		evening peak	evening peak	evening peak	evening peak					40	40	
Mizoram	40	40	40	40	40	40	40					NIL
Mizoram								peak	peak	peak	peak	

v quantum to be submitted by states
 v/2 mid of month
 * peak hours
 ^ off-peak hours

State	GNA	Total LTA+MTOA	Inside Region (LTA+MTOA)	Outside Region(LT A+MTOA)	Inside region(GNA)	Outside Region (GNA)
	A	B	C	D	E=C/B*A	F=A-E
Chandigarh	342	392	349	43	305	37
Delhi	4,810	5,443	3,324	2,119	2,938	1,872
Haryana	6,913	5,648	3,247	2,401	3,974	2,939
Himachal pradesh	1,130	1,744	1,722	22	1,116	14
Jammu & Kashmir	1,977	2,329	2,099	230	1,782	195
Punjab	5,497	4,660	2,423	2,238	2,858	2,639
Rajasthan	5,755	4,392	2,899	1,493	3,798	1,957
Uttar Pradesh	10,165	13,339	8,677	4,663	6,612	3,553
Uttarakhand	1,402	1,269	1,098	170	1,214	188
Railways-NR-ISTS-UP	130	257	-	257	-	130
PG-HVDC-NR	8	9	9	-	8	-
Chattisgarh	2,149	2,331	2,077	255	1,914	235
Dadra Nagar Haveli	792	1,034	1,031	3	790	2
Daman Diu	334	447	445	2	333	1
Goa	548	643	641	2	546	2
Gujarat	6,434	9,375	7,953	1,422	5,458	976
Madhya Pradesh	7,361	9,053	7,773	1,279	6,321	1,040
Maharashtra	8,496	8,842	7,613	1,229	7,315	1,181
Essar-Steel	563				200	363
PG-HVDC-WR	5	7	7	-	5	-
BARC	5	9	9	-	5	-
Andhra Pradesh	4,516	3,220	3,220	-	4,516	-
Karnataka	4,376	7,380	6,946	434	4,119	257
Kerala	2,679	2,855	1,630	1,225	1,530	1,149
Puducherry	398	513	513	-	398	-
Tamil nadu	9,177	9,016	6,474	2,542	6,590	2,587
Telangana	6,140	4,766	3,302	1,464	4,254	1,886
PG-HVDC-SR	6	8	8	-	6	-
Bihar	5,043	6,624	5,743	881	4,373	670
DVC	956	640	640	-	956	-
Bangladesh	782	782	346	436	346	436
Jharkhand	1,110	1,158	641	517	614	496
Odisha	2,157	2,328	1,578	750	1,462	695
Sikkim	111	93	93	-	111	-
West Bengal	3,946	2,408	2,408	-	3,946	-
PG-HVDC-ER	2	2	2	-	2	-
Arunachal Pradesh	134	288	282	6	131	3
Assam	1,529	1,727	1,331	396	1,178	351
Manipur	204	218	218	-	204	-
Meghalaya	238	256	256	-	238	-
Mizoram	95	137	132	5	92	3
Nagaland	134	194	181	14	125	9
Tripura	311	302	302	-	311	-
PG-HVDC-NER	1	1	1	-	1	-

- Itanagar 132kV D/c line at Gohpur. The LILO along with bays at Gohpur would be implemented by AEGCL.
- 5.3 GM, POWERGRID said that the existing 132 kV sub-station at Gohpur has single main bus switching arrangement, which can impact reliability of the system. DGM, AEGCL said that to improve reliability, the switching scheme at Gohpur 132 kV S/s would be modified from single main bus to double main bus scheme.
- 5.4 Chief Engineer, CEA stated that Biswanath Chariali (PG) – Itanagar 132kV D/c line is an ISTS line being implemented as a part of NERSS-II through TBCB and LILO of an ISTS line should preferably be implemented as ISTS work. He requested AEGCL to confirm the availability of space for 2 no. 132 kV bays at Gohpur for the proposed LILO and implementing double main bus switching scheme at Gohpur.
- 5.5 DGM, AEGCL stated that the availability of space for 2 no. 132 kV bays at Gohpur and implementing double main bus switching scheme at Gohpur would be informed to CEA after the site visit.
- 5.6 GM, POWERGRID informed that RfP for the scheme NERSS-II Part-B and NERSS-V has been issued in Sep. 2016 and bidders are to be informed about the change in scope before the bid submission date.
- 5.7 After further discussion, it was decided that the LILO of one circuit of Biswanath Chariali (PG) – Itanagar 132kV D/c at Gohpur (AEGCL) would be implemented through TBCB as ISTS work as a part of NERSS-II Part-B and the scope of works of NERSS-II Part-B would be modified accordingly. It was also decided that AEGCL would implement the double main bus switching scheme at Gohpur 132 kV S/S along with 2 no. 132 kV bays at Gohpur before Dec., 2019.
- 5.8 Subsequently, AEGCL vide its letter no. AEGCI/MD/13th Plan/Tech -593/2014-15/9 dated 30-11-2016 (copy enclosed at Annexure-II) has informed that due to space constraint at Gohpur for accommodating double main bus switching scheme, they have proposed to switch over from AIS to GIS at Gohpur 132 kV S/S along with implementation of 2 no. 132 kV GIS bays for the LILO of one circuit of Biswanath Chariali (PG) – Itanagar 132kV D/c at Gohpur (AEGCL).

6.0 Strengthening of evacuation system of Pare HEP of NEEPCO

- 6.1 Director, CEA stated that Pare HEP by NEEPCO is expected to be commissioned by Dec., 2016. Evacuation system from Pare HEP consist of
- i) LILO of Ranganadi-Naharlagun / Nirjuli 132 kV S/C line at pare HEP
 - ii) LILO of one circuit of Ranganadi-Itanagar 132 kV D/C line at Pare HEP.
- 6.2 He added that out of four 132 kV lines evacuating from Pare HEP, two are connected to Ranganadi HEP and remaining two to the load centres viz. Naharlagun and Itanagar. System studies have been carried out for 2018-19 time-frame corresponding to high hydro and low hydro conditions. It is observed that Ranganadi HEP injects power at Pare HEP through Pare – Ranganadi 132kV 2xS/c lines, thereby leaving only 2 no. 132kV S/c lines i.e. Pare – Itanagar and Pare – Naharlagun / Nirjuli for evacuation of 110MW power

from Pare HEP and additional power injected at Pare HEP from Ranganadi HEP. This causes overloading of Pare – Naharlagun / Nirjuli 132kV S/c line (Pare – Naharlagun: 129MW, Naharlagun – Nirjuli: 91MW). In order to overcome this situation, following transmission system modification is proposed to be implemented as NERSS-IX:

- (i) Bypassing of LILO of Ranganadi - Naharlagun / Nirjuli at Pare HEP so as to form direct Ranganadi - Naharlagun / Nirjuli 132 kV S/C line - ISTS by NEEPCO
 - (ii) Pare HEP (From LILO point) – North Lakhimpur (AEGCL) 132kV D/c line (with ACSR Zebra conductor) – along with 2 no. 132 kV bays at North Lakhimpur ISTS through TBCB
 - (iii) LILO of one circuit of Pare HEP – North Lakhimpur (AEGCL) 132kV D/c line (with ACSR Zebra) at Nirjuli substation – ISTS through TBCB
 - (iv) Re-conductoring of LILO portion at Pare end (of Ranganadi – Naharlagun / Nirjuli 132kV S/c line) with HTLS (HTLS equivalent to ACSR Zebra) along with modification of 132kV bay equipment at Pare HEP – by NEEPCO.
- 6.3 DGM, NEEPCO stated that 132 kV bay equipment at Pare HEP had already been erected.
- 6.4 Director, CEA stated that to recover additional investment in the transmission and bay equipment modification as suggested above, M/s NEEPCO may file revised tariff petition in CERC. He enquired about the availability of space at North Lakhimpur 132 kV S/S for termination of Pare-North Lakhimpur 132 kV D/C line and at Nirjuli for LILO of one circuit of Pare-North Lakhimpur 132 kV D/C line.
- 6.5 DGM, AEGCL informed that space for two number 132kV line bays at North Lakhimpur is available. GM, POWRGRID also confirmed the availability of space for 2 no. 132 kV line bays at Nirjuli S/S.
- 6.6 After further discussion, following additional / modification in the transmission system associated with Pare HEP was agreed as a part of NERSS-IX.
- a. Bypassing of LILO of Ranganadi - Naharlagun / Nirjuli at Pare HEP so as to form direct Ranganadi - Naharlagun / Nirjuli 132 kV S/C line – ISTS by NEEPCO.
 - b. Pare HEP (from LILO point) – North Lakhimpur (AEGCL) 132kV D/c line (with ACSR Zebra conductor) along with 2 no. 132 kV line bays at North Lakhimpur – ISTS (implementation through TBCB/RTM to be decided by empowered committee).
 - c. LILO of one circuit of Pare HEP – North Lakhimpur (AEGCL) 132kV D/c line (with ACSR Zebra) at Nirjuli substation – ISTS (implementation through TBCB/RTM to be decided by empowered committee).
 - d. Re-conductoring of LILO portion at Pare end (of Ranganadi – Naharlagun / Nirjuli 132kV S/c line) with HTLS (HTLS equivalent to ACSR Zebra) along with modification of 132kV bay equipment at Pare HEP – ISTS by NEEPCO

- e. 2 no. 132 kV bays at Nirjuli S/S for termination of LILO of one circuit of Pare HEP – North Lakhimpur (AEGCL) 132kV D/c line (with ACSR Zebra) – ISTS by POWERGRID.

7.0 Augmentation of 2x30MVA, 220/132kV substation at Mokokchung (PG)

- 7.1 Director, CEA stated that Mariani (PG)-Mokokchung (PG) 220 kV D/C line supplies power to 2x30 MVA 220/132 kV S/S at Mokokchung (PG) SS, which in turn feeds power to Mokokchung & other downstream areas of Nagaland. Thus, Mokokchung (PG) substation is a vital node for supplying power to Nagaland. He added that under N-1 contingency of ICT at Mokokchung the other ICT would be over loaded and loading has to be restricted to 30 MW. So it was proposed to enhance the transformation capacity at Mokokchung (PG) by installation of third 220/132 kV ICT of 30MVA (3x10MVA) single phase units.
- 7.2 Director, CEA stated that Mokokchung (PG) belongs to POWERGRID, so augmentation should be done by POWERGRID. The tariff policy in vogue does not exempt implementation of augmentation of sub-station from TBCB. Empowered Committee will take the decision whether the project will be done by POWERGRID or it goes through TBCB.
- 7.3 GM, POWERGRID informed that the Mokokchung is a GIS station.
- 7.4 After further discussions, augmentation of 220/132 kV Mokokchung (PG) S/S by 30 MVA (3x10 MVA single phase) was agreed to be implemented as ISTS work with GIS bays as a part of NERSS-VIII. Executing agency for the augmentation would be decided by the Empowered Committee on transmission.

8.0 Conversion of 2 nos. 63 MVAR Line Reactors at Bishwanath Chariali end of Biswanath Chariali – Lower Subansiri 400kV (1st) D/c line to Bus Reactors

- 8.1 Director, CEA stated that power evacuation system from Lower Subansiri HEP inter-alia, consist of Lower Subansiri - Biswanath Chariali 400 kV 2xD/C lines along with 4x80 MVAR line reactors at Biswanath Chariali. POWERGRID has informed that due to delay in the commissioning of Lower Subansiri HEP, construction of Lower Subansiri - Biswanath Chariali lines have been deferred and the 4 nos. 420kV, 63MVAR line reactors at Biswanath Chariali of the lines are not being used at this moment.
- 8.2 He added that due to high voltages observed at 400kV level at Biswanath Chariali, Balipara and Ranganadi substations, numbers of 400 kV lines from Bongaigaon, Balipara, Biswanath Chariali, Ranganadi are being kept open in off peak hours to maintain the nodal voltages within stipulated limits.
- 8.3 He also said that presently 420 kV 2x80MVAR Bus Reactors are in service at Biswanath Chariali. So, in order to contain high voltage in upper Assam and Arunachal Pradesh, POWERGRID has proposed that two out of four 63 MVAR Line Reactors at Biswanath Chariali may be utilized as Bus Reactors.
- 8.4 GM, POWERGRID suggested that in order to have better control of the over voltages all the four line reactors may be converted as bus reactors.



ISO 9001 & 14001
OHSAS 18001

नॉर्थ ईस्टर्न इलेक्ट्रिक पावर कॉर्पोरेशन लिमिटेड

(भारत सरकार का उद्यम)

NORTH EASTERN ELECTRIC POWER CORPORATION LTD.

(A Government of India Enterprise)

No. CMD/ND/120/ 1516

दिनांक/Dated: 05.11.2020

सेवा में/To,

The Chairperson

Central Electricity Authority,

Sewa Bhawan,

R. K. Puram,

New Delhi-100066.

विषय/Sub: Strengthening of evacuation system of Pare HEP of NEEPCO.

महोदय/ Dear Sir,

Reference is invited to the minutes of 6th Meeting of Standing Committee on Power System Planning of North Eastern Region wherein a new evacuation system has been formulated for Pare HE Plant keeping in mind the strengthening of the evacuation system as a part of the North Eastern Region Strengthening Scheme – IX (NERSS-IX) as follow:

- By-passing of LILO of Ranganadi - Naharlagun / Nirjuli at Pare HEP so as to form direct Ranganadi - Naharlagun / Nirjuli 132 kV S/C line –by NEEPCO.
- Pare HEP (from LILO point) – North Lakhimpur (Assam Electricity Grid Corpn.Ltd AEGCL) 132kV D/C line (with ACSR Zebra conductor) along with 2 no. 132 kV line bays at North Lakhimpur – ISTS (implementation through Tariff-Based Competitive Bidding (TBCB)/ Regulated Tariff Mechanism (RTM) to be decided by empowered committee).
- LILO of one circuit of Pare HEP – North Lakhimpur (AEGCL) 132kV D/C line (with ACSR Zebra) at Nirjuli substation – ISTS (implementation through TBCB/RTM to be decided by empowered committee).
- Re-conductoring of LILO portion at Pare end (of Ranganadi – Naharlagun / Nirjuli 132kV S/c line) with HTLS (HTLS equivalent to ACSR Zebra) along with modification of 132kV bay equipment at Pare HEP – by NEEPCO.
- 2 no. 132 kV bays at Nirjuli S/S for termination of LILO of one circuit of Pare HEP – North Lakhimpur (AEGCL) 132kV D/c line (with ACSR Zebra) – ISTS by POWERGRID

From the discussion held in the 2nd meeting of North Eastern Regional Power Committee (Transmission Planning) (NERPCTP), it is revealed that the work under the scope of sl. no. at (b) and (c) above are allotted under TBCB and presently in progress.

While acknowledging the effort of CEA in regard to reliable and effective transmission planning in the Country as a whole and for NE Region in particular, we would like to bring the following submission for your kind consideration: -

पंजीकृत कार्यालय: ब्रुकलैंड कम्पाउंड, लोअर न्यू कॉलोनी, शिलांग-793003

REGISTERED OFFICE: Brookland Compound, Lower New Colony, Shillong-793003

ईपीएबीएक्स/EPABX: (0364) 2224487 ☐ फैक्स/FAX : (0364) 2226417; CIN - U40101ML1976GOI001658

☑ /NEEPCOIndia 🐦/NEEPCOIndia : neepco.co.in

CIN - U40101ML1976GOI001658



नॉर्थ ईस्टर्न इलेक्ट्रिक पावर कॉर्पोरेशन लिमिटेड

(भारत सरकार का उद्यम)

NORTH EASTERN ELECTRIC POWER CORPORATION LTD.

(A Government of India Enterprise)

1. You are aware that the 2X55 MW Pare HE Plant in the State of Arunachal Pradesh was commissioned by NEEPCO in May 2018 with a time overrun of 70 months which in turn led to cost overrun for reasons beyond the control of the Corporation.
2. The evacuation system from the Plant was executed as per the approved scheme of CEA.
3. The present normative tariff based on the cost allowed by CERC stands at Rs. 7.23 per unit which is considered to be on the higher side by the beneficiary States of the Plant. NEEPCO was compelled to relook at the tariff structure and are trying to lower down the tariff to a comfortable level of beneficiaries for smooth operation of the Plant with partial recovery of capital cost and utilization of the natural resources to the fullest extent. This has led to absorption of substantial financial burden in the form of under recovery.
4. Further addition of the capital cost involved with the revised transmission scheme as stated above, shall either add burden to the beneficiaries or to the Corporation.
5. NEEPCO generally is not involved with the execution of transmission line and hence it is not possible to take up the work under the scope at sl. nos. (a) & (d) on its own. Engagement of other agency again, will lead to increase in the completion cost.

Sir, you will appreciate that commissioning of hydro projects in NE Region, itself is a challenging job. Being an organization with business area restricted to NE Region only, NEEPCO has to absorb a lot of challenges including financial losses. NEEPCO is not at all in a position to take further financial burden at this juncture.

Under the compelling circumstances, we would like to request you to kindly relieve NEEPCO from further investment against Pare HE Plant and hence, the work under the scope at sl. no.- (a) and (d) may be taken up through the successful TBCB agencies or otherwise expenditure may be granted from Power System Development Fund (PSDF)/ MoDONER as the same is under system strengthening scheme.

This is for your kind review and consideration please.

With regards,

भवदीय/yours faithfully

(V. K. Singh)

Chairman and Manging Director

Copy for kind information to: -

1. Joint Secretary (H), Ministry of Power, Govt. of India, Shram Shakti Bhawan, New Delhi

पंजीकृत कार्यालय: ब्रुकलैंड कम्पाउंड, लोअर न्यू कॉलोनी, शिलांग-793003

REGISTERED OFFICE: Brookland Compound, Lower New Colony, Shillong-793003

ईपीएबीएक्स/EPABX: (0364) 2224487 □ फ़ैक्स/FAX : (0364) 2226417; CIN - U40101ML1976GOI001658

Facebook /NEEPCOIndia Twitter /NEEPCOIndia : neepco.co.in

CIN - U40101ML1976GOI001658

I/17239/2021

ANNEX 5.2C



सत्यमेव जयते

भारत सरकार

Government of India

विद्युत मंत्रालय

Ministry of Power

केंद्रीय विद्युत प्राधिकरण

Central Electricity Authority

विद्युत प्रणाली योजना एवं मूल्यांकन प्रभाग-II

Power System Planning & Appraisal Division-II

सेवा में / To

As per list of Addresses

विषय/Subject: Minutes of meeting held on 17.08.2021 to discuss issues related to Strengthening of evacuation system of Pare HEP of NEEPCO.

महोदय/Sir,

To discuss the issues related to strengthening of evacuation system of Pare HEP of NEEPCO, a meeting was held under the chairmanship of Chief Engineer (PSPA-II), CEA on 17.08.2021. The minutes of the meeting are enclosed herewith.

Encl.: As above.

भवदीय/Yours faithfully,

Signature Not Verified

Digitally signed by

B.S.BAIRWA

Date: 2021.08.18 18:06:55 IST

(बी.एस. बैरवा/ B.S. Bairwa)

निदेशक/Director

I/17239/2021

List of Addresses:

1	The Member Secretary, North Eastern Regional Power Committee(NERPC), Meghalaya State Housing Finance Co-Operative Society Ltd. Building Nongrim Hills, Shillong (Meghalaya) – 793003	2	COO(CTU), Power Grid Corporation of India Ltd., “Saudamini” Plot no-2, Sector-29, Gurugram-122001, Haryana
3	Executive Director National Load Despatch Centre B-9, Qutab Institutional Area New Delhi-110016	4	Executive Director , North Eastern Load Despatch Centre (NERLDC), Power System Corporation Operation Limited (POSOCO) POWERGRID Complex, Dongteih, Lower Nongrah, Lapalang, Shillong- 793006, Meghalaya, India
5	The Chairman and Managing Director North Eastern Electric Power Corporation Ltd. Brookland Compound, Lower New Colony, Shillong (Meghalaya)- 793003		

Copy to:

PPS to Member (PS), Central Electricity Authority, Sewa Bhawan, R. K. Puram, New Delhi.

I/17239/2021

Minutes of the meeting held on 17.08.2021 to discuss issues related to Strengthening of evacuation system of Pare HEP of NEEPCO

A meeting to discuss the issues related to strengthening of evacuation system of Pare HEP of NEEPCO was held on 17.08.2021 via video conferencing which was participated by CEA, CTU and NEEPCO. NERPC and NERLDC could not participate due to non-availability of internet in Shillong during this time. List of Participants is enclosed at **Annexure-I**. Chief Engineer (PSPA-II), CEA welcomed the participants in the meeting. He requested Director (PSPA-II), CEA to brief the agenda.

1. Director (PSPA-II), CEA stated that in the 06th meeting of SCM-NER held on 03.10.2016, for strengthening of evacuation system of Pare HEP of NEEPCO, following additional/ modification in the transmission system associated with Pare HEP were to be carried out by NEEPCO as a part of NERSS-IX:
 - i. Bypassing of LILO of Ranganadi - Naharlagun / Nirjuli at Pare HEP so as to form direct Ranganadi - Naharlagun / Nirjuli 132 kV S/C line.
 - ii. Re-conductoring of LILO portion at Pare end (of Ranganadi – Naharlagun / Nirjuli 132kV S/c line) with HTLS (HTLS equivalent to ACSR Zebra) along with modification of 132kV bay equipment at Pare HEP.

He, further stated that NEEPCO vide their letter dated 19.07.2021 has intimated their difficulty to carry out the above works because of financial hardship. He requested NEEPCO to state the issue in implementation of the works which were agreed in 2016.

2. Representative of NEEPCO stated that the present normative tariff based on the cost allowed by CERC stands at Rs. 7.23 per unit which is considered to be on the higher side by the beneficiary States in NER. NEEPCO was compelled to relook at the tariff structure and are trying to lower down the tariff to a comfortable level of beneficiaries for smooth operation of the Plant with partial recovery of capital cost and utilization of the natural resources to the fullest extent which is of the order of Rs. 5/unit. This has led to absorption of substantial financial burden in the form of under recovery. Therefore, NEEPCO is not in a position to do any further investment w.r.t. works agreed under NERSS-IX.
3. Chief Engineer (PSPA-II), CEA enquired whether NEEPCO had estimated the scope of works to be implemented by NEEPCO and its cost estimates.
4. Representative of NEEPCO informed that they had not carried out the detailed exercise of estimating the scope of the works to be done and its cost implication. However, roughly, it is estimated that reconductoring works (with HTLS Zebra conductor) of around 1.5 km for D/c line from Pare HEP to LILO point and its stringing is pending. Bus, 2 circuit breakers and isolators at Pare HEP are rated at capacity of 1600A. All the CTs are with CTs ratio of 800A. As such, if HTLS is carried out with Zebra equivalent, then all the CTs of these two bays (around 07 including 01 spare) may also need to be replaced.

I/17239/2021

5. Representative of CTU stated that in NER, as per the estimates of their engineering team, reconductoring of 132kV S/c line costs around Rs. 30-35 lacs per km per circuit. He also stated that for Zebra conductor, the ampacity is only 770A (at 85°C considering ambient temperature of 45°C) as given in recent RFP. As such, the CTs of 800A may not need replacement. NEEPCO need to definitely carry out the works of Bypassing of LILO of Ranganadi - Naharlagun / Nirjuli at Pare HEP so as to form direct Ranganadi - Naharlagun / Nirjuli 132 kV S/C line. Otherwise, the works carried out by the TSP i.e. Pare HEP (from LILO point) – North Lakhimpur (AEGCL) 132kV D/c line (with ACSR Zebra conductor) along with 2 no. 132 kV line bays at North Lakhimpur, will remain idle.
6. Representative of CTU presented the system study and implication of not reconductoring the lines (enclosed at **Annexure-II**). He stated that in base case (wherein planned system is assumed to be taken up), with Pare HEP generation at 110MW and Ranganadi HEP generation at 360MW, flow on Pare-N.Lakhimpur and Pare-Nirjuli 132kV S/c lines is of the order of 62-67 MW. However, in case of N-1 contingency of Pare-N.Lakhimpur 132kV S/c line, flow on Pare-Nirjuli 132kV S/c line becomes 93 MW which is more than the thermal limit of the line. This was the reason of planning reconductoring of LILO portion with HTLS Zebra line. To reduce the flow below 90MW, generation at Pare HEP needs to be reduced from 110MW to 80 MW.
7. Chief Engineer (PSPA-II), CEA stated that in case only reconductoring of LILO portion is to be carried out, then it should not cost more than Rs. 1.5 Crores. He suggested that this small investment by NEEPCO can be recovered through tariff or some alternate arrangement like fund pooling by NER states can be considered, which may be supported by NERPC, if possible. He further stated that as evident from the studies, if the system is not implemented by NEEPCO, they may have to back down generation of Pare by about 30MW to keep the line loading within limits. The commercial decision of implementing this scheme v/s backing down the generation needs to be taken by NEEPCO.
8. Representative of NEEPCO stated that straightening of line would also require erection of new towers and may need some more funds. However, they will put up these suggestions to their management which will take the final decision.

Chair thanked all the participants for valuable time and suggestions.

I/17239/2021

Annexure-I**List of participants to the meeting****CEA:**

1. Shri Pardeep Jindal, Chief Engineer (PSPA-II)
2. Shri B.S. Bairwa, Director (PSPA-II)
3. Shri Deepanshu Rastogi, Deputy Director (PSPA-II)
4. Sh. Manish Maurya, Assistant Director (PSPA-II)

CTUIL:

1. Shri Ashok Pal, CGM (CTU)
2. Shri Manish Ranjan Keshari, Manager (CTU)

NEEPCO:

1. Shri Saamarjit Chakravarty, ED-O&M
2. Shri Bhaskar Goswami, DGM, O/O ED (O&M)
3. Shri Joypal Roy, DGM, O/O ED-O&M

Arunachal Pradesh: Transmission System

Base Case

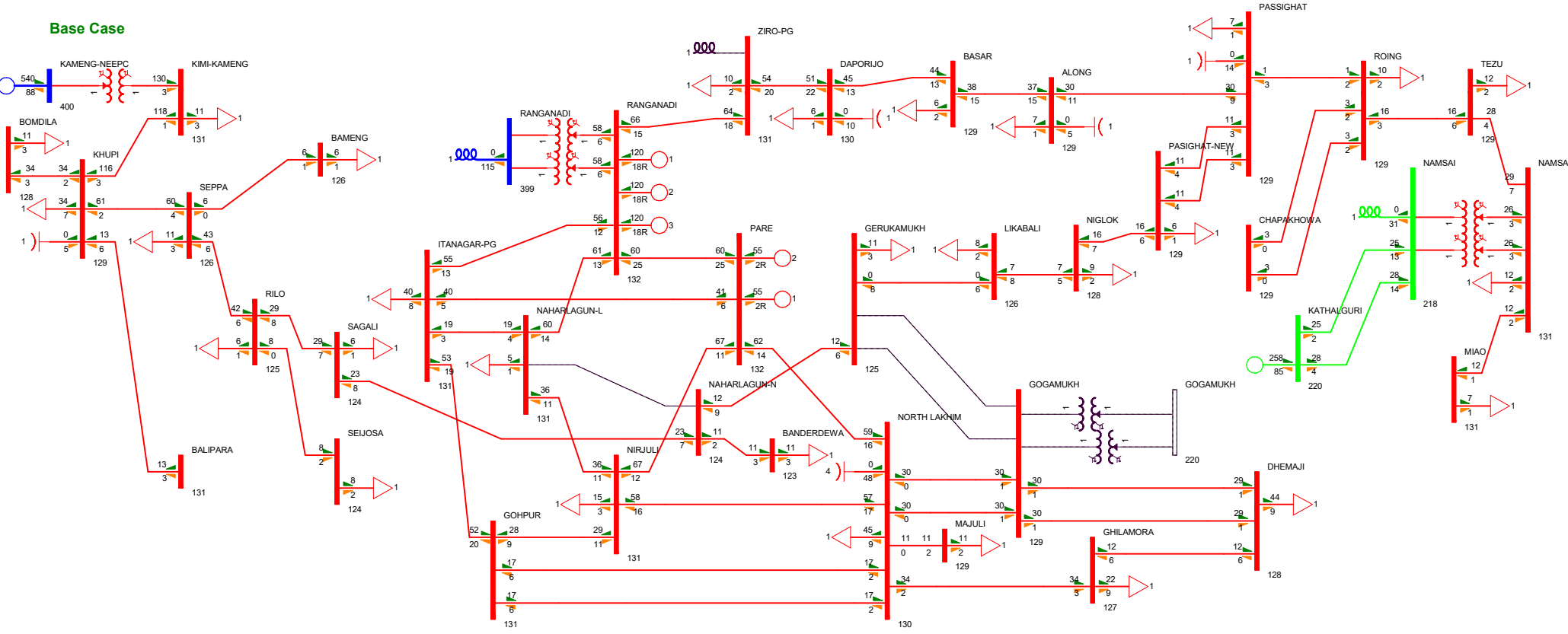

Arunachal Pradesh: Transmission System

N-1 of Pare-North Lakhimpur

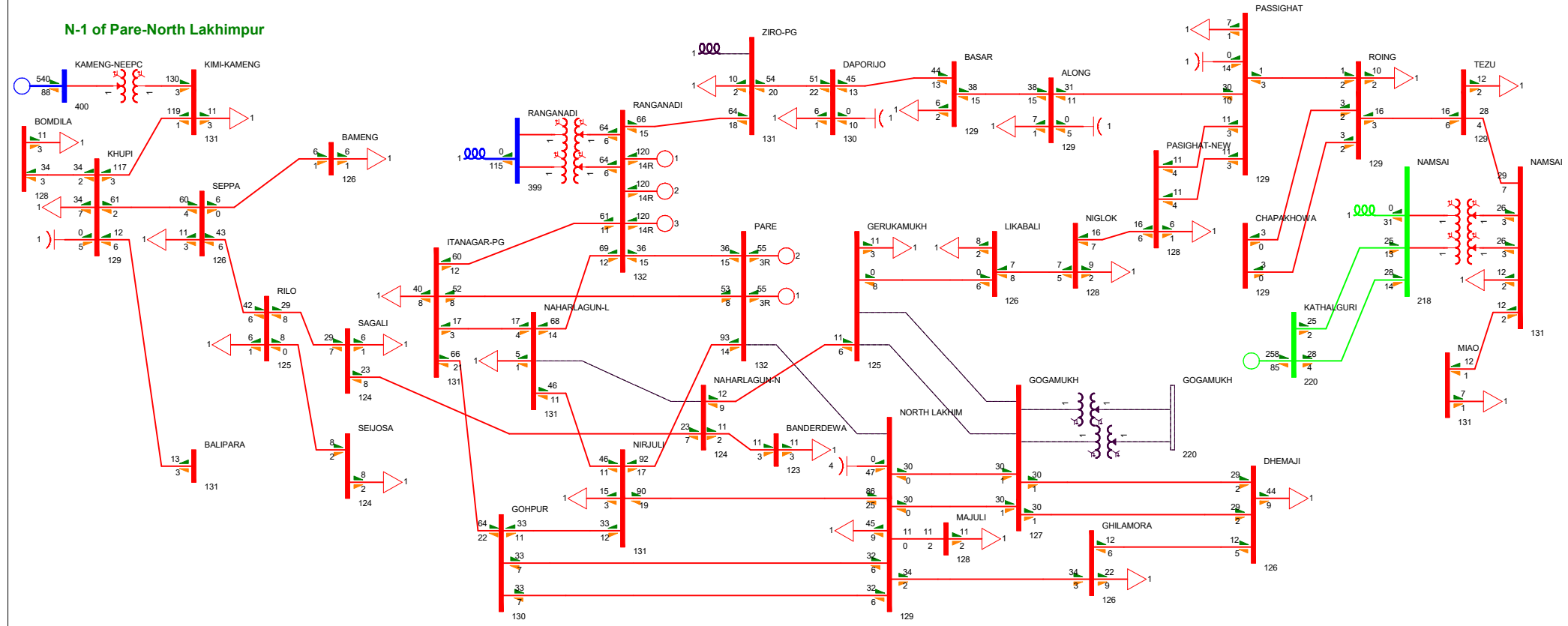

Arunachal Pradesh: Transmission System

N-1 of Pare-North Lakhimpur with 80MW at Pare HEP

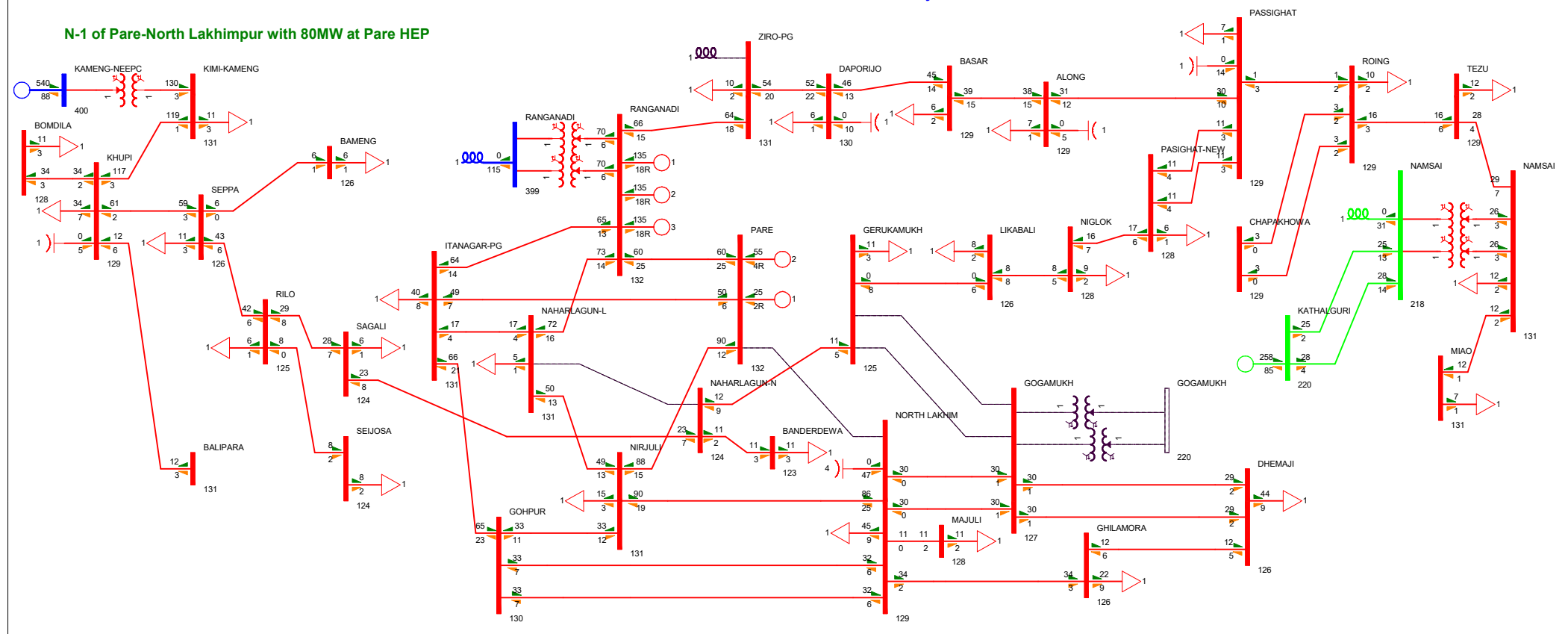

ANNEX 5.2D



भारत सरकार

Government of India

विद्युत मंत्रालय

Ministry of Power

केंद्रीय विद्युत प्राधिकरण

Central Electricity Authority

विद्युत प्रणाली योजना एवं मूल्यांकन प्रभाग-II

Power System Planning & Appraisal Division-II

सेवा में / To

Sh. H.K. Deka

Director (Technical)

North Eastern Electric Power Corporation Ltd.

Brookland Compound, Lower New Colony,

Shillong (Meghalaya)- 793003

विषय/Subject: New Evacuation system for 110 MW Pare HE Plant, Arunachal Pradesh, under the North Eastern Region Strengthening Scheme -IX (NERSS - IX) -reg.

सन्दर्भ/Reference: NEEPCO letter No. NEEPCO/D(T)/PHEP-7/2021-22/185 dated 19.07.2021

महोदय/Sir,

This has reference to NEEPCO letter dated 19.07.2021 requesting to relieve NEEPCO from further investment against Pare HEP for the following scope of works (agreed under NERSS-IX):

- Bypassing of LILO of Ranganadi - Naharlagun / Nirjuli at Pare HEP so as to form direct Ranganadi - Naharlagun / Nirjuli 132 kV S/C line.
- Re-conductoring of LILO portion at Pare end (of Ranganadi – Naharlagun / Nirjuli 132kV S/c line) with HTLS (HTLS equivalent to ACSR Zebra) along with modification of 132kV bay equipment at Pare HEP.

In this regard, it is to mention that scheduled commissioning date of Pare HEP (NEEPCO) (from near LILO point)– North Lakhimpur (AEGCL) 132 kV D/c line (with ACSR Zebra conductor) along with 2 no. 132 kV line bays at North Lakhimpur end by TSP i.e. Sterlite is 22.06.2023.

In case, scope of re-conductoring works is not completed by NEEPCO, the line section being implemented by TSP will have to be connected to existing LILO point. This will result in reduction of the capacity of Pare-North Lakhimpur 132kV D/c line via Nirjuli.

File No.CEA-PS-12-16/3/2018-PSPA-II Division

1065

I/17269/2021

To assess the implication of restricted capacity of transmission line, system studies were carried out by CTU and discussed in a meeting held under the chairmanship of Chief Engineer (PSPA-II), CEA on 17.08.2021 with participation from CEA, CTU and NEEPCO (Minutes of the meeting are enclosed at Annexure). It was found that in case of N-1 contingency of Pare-North Lakhimpur 132kV S/c line, flow on Pare-Nirjuli 132kV S/c line becomes more than the thermal limit of the line. To reduce the flow on the transmission line for safe operation of NER grid, the generation of Pare HEP will have to be reduced to 80 MW from 110MW.

In the meeting, it was also brought out that the commercial decision of implementing this scheme v/s backing down the generation needs to be taken by NEEPCO.

Therefore, you are requested to inform your decision in this regard.

भवदीय/Yours faithfully,

संलग्न/Encl.: As above.

Pradeep Jindal
23/08/2021

(प्रदीप जिंदल/ Pardeep Jindal)

मुख्य अभियंता/Chief Engineer

प्रतिलिपि/Copy to:

1. Director (Trans.), MoP, New Delhi
2. ED, NERLDC, Shillong
3. COO, CTU, Gurugram

North Eastern Regional Power Committee

MINUTES OF SPECIAL MEETING TO DISCUSS IMPORTANT ISSUES**PERTAINING TO 132kV PARE-NORTH LAKHIMPUR**

Date : 18/11/2021 (Thursday)
Time : 11:00 hrs
Venue : NERPC Shillong (over Video-Conferencing).

The List of Participants in the Meeting is attached at **Annexure – I**

Sh. B. Lyngkhai, Member Secretary(i/c), NERPC welcomed all the members to the meeting. He informed that in follow-up to CEA Special Meeting held on 17th August 2021 this meeting has been convened. Further he intimated the members that minor modification has been sought by NEEPCO regarding HTLS upgradation of LILO portion, for which discussion is still ongoing with CEA. He requested the members to discuss in detail the following issues:

1. Pare evacuation via approved 132 kV Pare- North Lakhimpur D/C
2. Upgradation of LILO portion of 132 kV Ranganadi - Lekhi at Pare.
3. Straightening of 132 kV Ranganadi-Nirjuli Lekhi line.

He appreciated the presence of participants from NEEPCO, NERTS and M/s STERLITE for discussion & requested DD, NERPC to take up the agenda item(s).

ITEM NO. 1 : PARE EVACUATION VIA APPROVED 132KV PARE-NORTH LAKHIMPUR D/C

The status of 132kV Pare- Nirjuli – N. Lakhimpur T/L and 132kV Pare – North Lakhimpur T/L

Deliberation in the meeting:

Representative of M/s STERLITE stated that the lines are in various stages of completion as follows:

Foundation: 14 out of 91 foundations for main line completed, all 57 foundations for LILO portion (S/C LILO at Nirjuli) to be done.

Arunachal Pradesh portion – From 16th Jan'22 (for Main line) material shifting will be done

He requested the forum to highlight the arrangement for termination at Pare HEP.

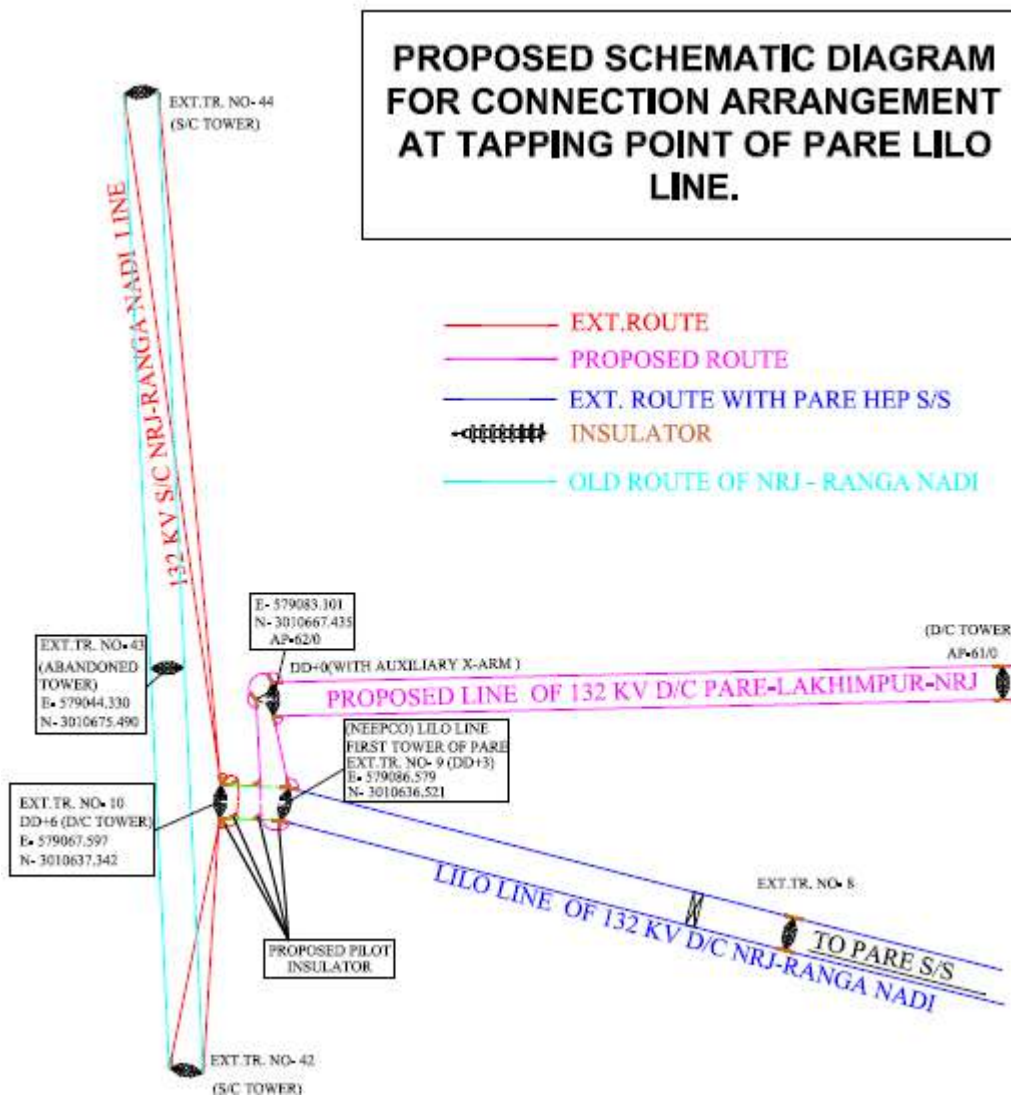

Fig.1.

Sr.GM(AM), NERTS stated that erstwhile NDTL line when LILO'ed at Pare one tower Loc 43 (of the original line) was abandoned and the line was terminated via two new towers Loc 10 and Loc 9 to Pare HEP. The same is shown in Fig.1 above.

On suggestion of the forum M/s STERLITE had submitted (on 15th Dec'21) the detailed engineering drawing with their proposed solution. The same is attached at **Annexure-I.**

Thereafter, a joint visit was carried out by NERTS-POWERGRID and M/s STERLITE and the following solution was agreed to:

- (i) To provide additional Auxiliary cross arms in 132kV Tower(DD type) at Loc 10 of the LILO portion so that Line will go directly from Nirjuli -Lekhi to Ranganadi via Loc 10, without any connection with 132kV D/C Pare-Lakhimpur line of M/s STERLITE. Necessary strengthening (if any) may be taken care of by NEEPCO Ltd. Arrangement proposed is shown in the sketch below:

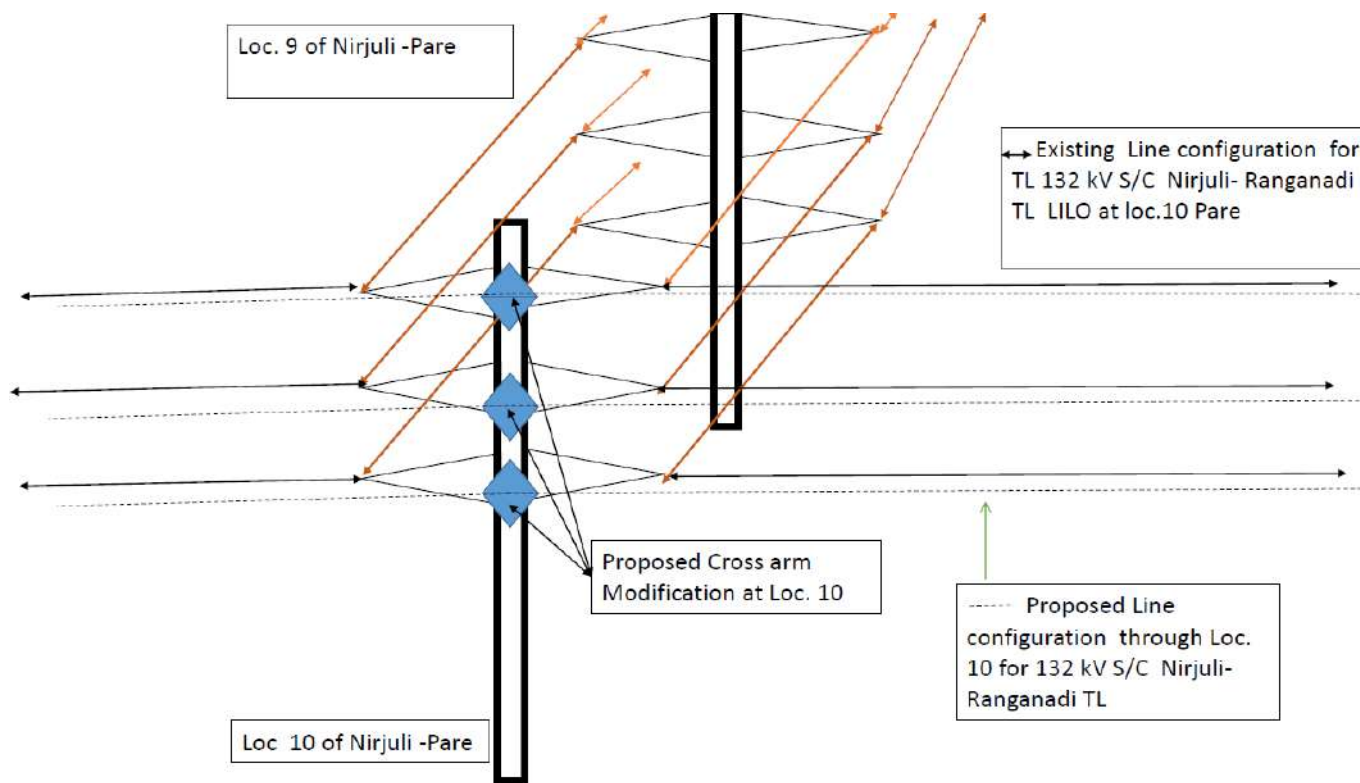

(ii) Connection of 132kV Pare-N.Lakhimpur and 132kV Pare-Nirjuli via Tower at Loc 9 as suggested by M/s STERLITE.

Also, mechanical strength verification of the towers/ conductors due to the proposed scheme of tapping from mid span between Loc 9 & Loc 10 to be looked into by M/S STERITE.

After detailed deliberation, the above solution was referred to NCT/CEA for approval.

The forum noted as above.

Action: NERTS, M/s STERLITE, NERPC.

ITEM NO. 2 : UPGRADATION OF LILO PORTION OF 132 KV RANGANADI - Lekhi AT PARE

At 6th Standing Committee Meeting held at Imphal on 03-10-2016 the following were decided(amongst others) under NERSS-IX:-

- *Bypassing of LILO of Ranganadi – Lekhi at Pare HEP so as to form direct Ranganadi – Lekhi 132kV S/C line – ISTS by NEEPCO*
- *Re-conductoring of LILO portion at Pare end (of Ranganadi – Lekhi 132kV S/C line) with HTLS (HTLS equivalent to ACSR Zebra) along with modification of 132kV bay equipment at Pare HEP – ISTS by NEEPCO*

Deliberation in the meeting

ED(O&M), NEEPCO intimated the forum regarding difficulties (to be faced) by NEEPCO in adjustment of tariff due to additional works. Further he intimated that NEEPCO has not received any offer from M/s STERLITE

GM(SO-II), NERLDC stated that (i)Thermal limit of the line(LILO portion) will be exceeded in event of full generation from Pare HEP without HTLS upgradation. Hence generation might have to be curtailed without upgradation, (ii)Existing CTR of 800/1 is sufficient, (iii)other bay equipments are to be upgraded.

The forum noted that the approximate cost under the above scope is around INR 2 Crores.

After detailed deliberation the forum suggested that once CEA approved the solution for termination of 132 Pare- North Lakhimpur D/C, the scope executing agency under this item shall be decided by NCT/CEA.

The forum noted as above.

Action: NERPC.

ITEM NO. 3 : STRAIGHTENING OF 132 KV RANGANADI-Lekhi LINE

Deliberation in the meeting

Representative of M/s STERLITE stated that in addition to straightening of 132kV RHEP- Lekhi line by bypassing of LILO at Pare HEP following additional issues must be addressed:

- (i) Continuance of fiber connectivity of Pare HEP
- (ii) PLCC for the two new lines to be terminated at Pare HEP
- (iii) Voice and data communication at Pare HEP

GM, NEEPCO stated that presently Pare HEP is communicating via OPGW laid on 132kV RHEP-Pare (NDTL) and the same is used for LDP of both circuits from 132kV RHEP-Pare HEP. He requested that the arrangement be not disturbed and in event of any changes due to bypassing alternative may be decided by the forum. Manager, NERTS stated that presently OPGW is laid till Pare HEP from RHEP. After detailed deliberation the forum decided to take up the above issues after finalization of above issues at Item No. 1&2.

The forum noted as above.

Action: NERPC.

Annexure-I

List of Participants in the Special Meeting held on 18.11.2021

SN	Name & Designation	Organization	Contact No.
1	Sh. S. Patel, Sr. GM(AM)	NERTS	-
2	Sh. Navin Mahato, CM(AM)	NERTS	-
3	Sh. P. Nandi, Manager (AM)	NERTS	-
4	Sh. Nabarun Roy, CGM (I/c)	NERLDC	-
5	Sh. Samar Chandra De, GM	NERLDC	-
6	Sh. Sourav Mandal, Dy. Mgr. (SO-I),	NERLDC	-
7	Sh. Chitra Thapa, SO-II	NERLDC	-
8	Sh. B. Lyngkhoi, MS(i/c)	NERPC	-
9	Sh. S. Mukherjee, Dy. Director	NERPC	-
10	Sh. Narottam Chakraborty	M/s STERLITE	
11	Sh. Arindam Kar	M/s STERLITE	
12	Sh Bhuwanesh Joshi	M/s STERLITE	
13	Sh. Sandip Maity	M/s STERLITE	

I/21368/2022

ANNEX 5.2F



भारत सरकार
 Government of India
 विद्युतमंत्रालय
 Ministry of Power
 केन्द्रीय विद्युत प्राधिकरण
 Central Electricity Authority
 विद्युत प्रणाली अभियांत्रिकी एवं प्रौद्योगिकी विकास प्रभाग
 Power System Engineering & Technology Development Division

To,

1. Executive Director (Engg),
Power Grid Corporation of India
Limited,
"Saudamini", Plot no.2, Sector-
29, Gurugram-122001.
Haryana
2. Narottam Chakraborty
Project Head-WRNER, Part-D
M/s. Sterlite Power

विषय: Minutes of Meeting held on 08.04.2022 under Chairmanship of Chief Engineer (PSETD),CEA to discuss the issue of Straightening of 132 kV Ranganadi-Pare-Nirjuli line-reg.

Reference: NERPC's letter no. NERPC/OP/Committee/2022/08 dated 01.04.2022

महोदय,

The minutes of the Meeting, held on 08.04.2022 under Chairmanship of Chief Engineer (PSETD), CEA to discuss the issue in detail and evaluate the available alternative arrangements for straightening of 132 kV Ranganadi-Pare-Nirjuli line, are attached herewith for information and necessary action please.

संलग्न /Encl. - उपरोक्त / as above.

भवदीय,

 मोहित मुद्गल
 उप निदेशक

I/21368/2022

Minutes of the Meeting taken by Chief Engineer (PSETD) on 08.04.2022 in CEA to discuss the issue of straightening of 132 kV Ranganadi-Pare-Nirjuli line with POWERGRID and M/s Sterlite.

List of Participants is attached an **Annex**.

1. Chief Engineer (PSETD), CEA welcomed all the participants and mentioned that NERPC vide its letter dated 01.04.2022 had invited reference to the discussions held during the 22nd TCC/RPC meeting on 26th March 2022 and requested CEA to examine and suggest the suitable alternatives for straightening of 132 kV Ranganadi-Pare-Nirjuli line so that the works can be executed by NEEPCO. He informed that this meeting has been called to discuss the issue in detail and requested participants to deliberate on the possible alternatives for straightening of 132 kV Ranganadi-Pare-Nirjuli line to finalise an all acceptable solution.
2. Powergrid representatives proposed the following two alternatives for straightening of 132 kV Ranganadi-Pare-Nirjuli line for deliberations. An indicative sketch for the following arrangements was also provided by Powergrid for reference. (Attached as Annexure-I)
 - a. **Option 1:** To restore the 132kV Ranganadi-Nirjuli line on original arrangement i.e., via the spare tower at location no 43 which is at present abandoned, provided that this is feasible and no ROW issue is involved. This option will ensure isolation of this line from tower at location 10.
 - b. **Option-2:** Dismantle tower no. 10 upto butt joint below cross arm level and re-erect the tower by rotating the cross arm/ tower by 90 degree so as to connect POWERGRID Line directly from Nirjuli to Ranganadi via Loc 10 and this line shall be completely isolated from LILO line.

Further, to connect the line from loc. No- 9 to loc. 62, additional Auxiliary cross arms shall be provided on the tower at loc. No -9. The BOM, Drawing and Shop Floor Drawing for Auxiliary cross-Arm shall be provided by POWERGRID.
3. The above mentioned proposals were discussed in detail and all the participants were generally in agreement to the proposed options. After deliberations, following was concluded:
 - a. The abovementioned proposals of POWERGRID are technically feasible and can be adopted for straightening of 132 kV Ranganadi-Pare-Nirjuli line.
 - b. One of the options mentioned above for implementation shall be explored based on the feasibility and techno-economic analysis.
 - c. While execution of the proposed arrangements, it shall be ensured that the all the necessary Safety and Electrical clearances, as specified in relevant regulations, are maintained.

- d. Only technical feasibility of the available options has been deliberated in the meeting and all the commercial/financial aspects of the proposals shall be mutually decided by the affected parties.

Meeting ended with a vote of thanks to the Chair.

ANNEX**List of Participants****CEA**

- | | |
|------------------------|--------------------------|
| 1. Shri. A. K. Thakur | Chief Engineer, PSETD |
| 2. Shri Y. K. Swarnkar | Director, PSETD |
| 3. Shri Mohit Mudgal | Deputy Director PSETD |
| 4. Shri. Manoj | Assistant Director PSETD |

POWERGRID

- | | |
|-----------------------------|---------------|
| 1. Shri. Nitesh Kumar Sinha | DGM (Engg-TL) |
| 2. Neeraj Singh Gautam | DGM (Engg-TL) |

M/s. Sterlite Power

1. Shri. Chandan Kalra
2. Shri. Amit Mahajan
3. Shri. Keshav Chandra

BESPOKE SOLUTIONS & CUTTING-EDGE PRODUCTS TO ENHANCE
POWER TRANSMISSION CAPABILITIES

132 KV D/C NEEPCO PARE LINE



Contents

- 1. Offer letter:.....2
- 2. Annexure A Commercial Proposal 3
 - A. Scope:3
 - B. Major Commercial Terms 3
- 3. Annexure B Bill of Quantities 5
- 4. Notes.....5

Reconductoring Proposal

1. Offer letter:

SPTL/FY 21-22/PARE/003

Date: 28/06/2022

To,

Tseten Sange

Dy. General Manager (E/M)

Pare HEP, NEEPCO Ltd

Sub: - Budgetary Proposal for Reconductoring of 132 KV D/C NEEPCO Pare Line

Dear Sir,

We take this opportunity to share with you that Sterlite Power Transmission Ltd is a leading global solution provider of Transmission projects, OPGW, Power cables and Power Transmission conductors and major player in HTLS conductors.

We hereby submit our offer for 132 KV D/C NEEPCO Pare Line: Reconductoring with ACCC along with necessary hardware, insulators and accessories.

Yours Sincerely

For Sterlite Power Transmission Limited.



Jayavant Bhamare

AVP- Sales & Business Development

2. Annexure A Commercial Proposal

A. Scope:

- I. Destraining and Restringing of 132 KV D/C NEEPCO Pare Line 2.25 Ckm Portion: Reconductoring with ACCC Casablanca conductor along with necessary hardware, insulators and accessories.
- II. Changing relay setting parameter using updated line configuration relay setting calculation to be done accordingly and implemented.
- III. Straightening of Ranganadi -Nirjuli line by changing cross arm orientation at Tower No.10 of LILO line of Pare.

The scope is limited to aforesaid only and does not include any scope towards ROW, transmission towers, substation works, bay works or any commissioning works related to any transmission line or substation.

B. Major Commercial Terms

#	Terms	Details
1	Payment Terms	<p>Supply</p> <ul style="list-style-type: none"> • 10% Advance • 85% on Dispatch of Materials • 5% on commissioning <p>Services</p> <ul style="list-style-type: none"> • 10% Advance • 85% against RA bills • 5% on commissioning <p>All payments to be made within 30 days of receipt of the invoice. Any delay in payment beyond 30 days shall lead to late payment surcharge @ rate of 14% per annum for the outstanding amount till the date of receipt of full payment.</p>
2	Warranty Period	12 months from completion of Reconductoring works.
3	ROW & Way Leave	<p>Shall be responsibility of the Utility. All approval, permissions, compensations and other cost related to ROW & Way leave shall be in scope of the Utility. Utility shall provide free and hindrance free access to site for carrying out the reconductoring works.</p>
4	Change in Law	Any increase in cost or taxes due to Change in Law shall be compensated to SPTL at actuals.

5	Offer Validity	45 days from the date of the offer.
6	Shutdown	Shutdown required for Reconductoring shall be provided by the Utility.
7	Delays not attributable to Contractor	Suitable time extension and reimbursement of demonstrable cost shall be given to Contractor for suspension of work or delays not attributable to contractor.
8	Additional / Extra Item	In case of any additional items beyond the BOQ given in Annexure-II below, the same shall be executed by the Contractor as per mutually agreed rates.
9	Limitation of Liability	The contractor shall not be liable to client for any indirect or consequential loss or damage and the aggregate liability of the Contractor under the contract shall not exceed the contract price.
10	Governing Law	The contract shall in all respects be construed and interpreted in accordance with the laws in force in India.
11	Completion Period	3 months from the date of release of advance
14	Cancellation/Termination	<p>In case of cancellation or termination of Contract for any reasons other than termination due to default of the Contractor, the following shall be paid by the Client :-</p> <p>a) For Work completed till the date of termination. b) Cost incurred by Contractor for demobilization including any losses to Contractor resulting due to order cancellation will be to CLIENT's account including any claims raised by suppliers, service providers, equipment providers & labour related cost.</p> <p>Any unpaid claims raised by the Contractor under the Contract.</p>

3. Annexure B Bill of Quantities

Project : - 132 kV D/C Neepeco Line					
SI No.	Supply BOQ	Qty	Unit	Unit Rate (INR)	Total Unit Rate (INR)
1	Carbon Fibre Composite Core type HTLS Conductor	7.1	KM	1763879	12479271
2	Single Suspension Pilot fitting for Carbon Fibre Composite Core type HTLS Conductor	14.0	Nos	14413	201781
3	Vibration Damper suitable for Carbon Fibre Composite Core type HTLS Conductor	114.0	Nos	4409	502663
4	120KN Single Tension Fitting for Carbon Fibre Composite Core type HTLS Conductor	111.0	Nos	73025	8105765
5	Terminal Pad without hole	27.0	Nos	7062	190683
6	Relay Setting & Control System Integration	1	Set	2519108	2519108
7	T Connectors	9	Nos.	10580	95222
8	ACSR Panther Dead-end	6	Nos.	39676	238056
9	ACSR Panther MSJ	6	Nos.	31741	190445
10	ACSR Panther Repair sleeve	4	Nos.	26451	105803
TOTAL SUPPLY (Exc. GST)					24628796
SI No.	Service BOQ	Qty	Unit	Unit Rate (INR)	Total Unit Rate (INR)
1	Destrining & Restringing	2.246	Per Ckt KM	5038216	11315833
2	Dismantling of ACSR conductor	0.052	Per Ckt KM	251911	13099
3	Stringing of ACSR Conductor	0.293	Per Ckt KM	629777	184525
4	Dismantling of crossarm & installation	1	Per Ckt KM	377866	377866
Total Services (Exc. GST)					11891324
Total (Supply & Services) Exc. GST					36520119
Rupees Three Crore Sixty Five Lacs Twenty Thousand One Hundred Nineteen Only					

4. Notes:

- a) Our offer is excluding GST @ 18%. Any change in rates of taxes, duties, levies shall be reimbursed at actuals by the Client.
- b) Our offers exclude any cost towards ROW and Tower Strengthening.
- c) The above Offer is fixed except for Conductor which is being offered on variable basis and price variation shall be as per weight to weight formula, considering LME Aluminium of USD 3664/MT and USD/INR exchange rate of INR 76.22 /USD. The conductor shall be payable based on actual LME and Exchange rate as on date of metal booking after award of the contract.
- d) Detailed terms and conditions shall be mutually agreed at the time of signing of the contract.

Annexure-6.1

पूर्वोत्तर क्षेत्र के वित्तीय वर्ष 2022-23 के विचलन बकाया की स्थिति (पिछले साल सहित)							
Deviation Outstanding status of NER for FY-2022-23 (including Last years O/S)							
	29-08-2022	04-09-2022	तक		आज की तारीख में/As on	16-09-2022	Figs in Lacs
घटक/Constituents	Week no of NER-23 of FY 2022-23				टोटल / TOTAL		O/S PAYABLE >13 WEEKS
	पूल के लिए देय / Payable to Pool	पूल से प्राप्य / Receivable from Pool	भुगतान किया / Paid	प्राप्त / Received	O/S Payable to Pool	O/S Receivable from Pool	
अरुणाचल प्रदेश / Ar. Pradesh	21017.83	5545.71	20719.17	5545.71	298.66	0.00	0.00
असम / Assam	55891.85	1313.24	55891.85	1294.98	0.00	18.26	0.00
मणिपुर / Manipur	4532.74	3039.24	4389.21	3039.24	143.53	0.00	31.12
मेघालय / Meghalaya	5474.67	9724.62	5474.67	9716.63	0.00	7.99	0.00
मिजोरम / Mizoram	6698.63	5139.70	6698.63	5105.08	0.00	34.62	0.00
नगालैंड / Nagaland	8343.54	2889.32	8343.54	2876.72	0.00	12.60	0.00
त्रिपुरा / Tripura	16244.60	11068.54	16186.58	11068.54	58.02	0.00	0.00
लोकतक / Loktak	85.40	1112.75	82.02	1112.75	3.37	0.00	0.00
नीपको / NEEPCo	3608.44	23460.23	3608.44	23420.94	0.00	39.29	0.00
ई आर/ ER	247161.51	596986.90	247161.51	594222.61	0.00	2764.29	0.00
ओटीपीसी/ OTPC	2585.22	6224.21	2578.34	6224.21	6.88	0.00	0.00
एनटीपीसी / NTPC	9847.72	4383.62	9757.65	4383.62	90.07	0.00	0.00
एन आर / NR	581191.40	245827.76	575416.47	245827.76	5774.93	0.00	0.00
बी.एन.सी / BNC	155.28	367.64	155.28	367.09	0.00	0.54	0.00
टोटल / TOTAL	962838.82	917083.50	956463.35	914205.90	6375.47	2877.59	

Annexure-6.2

REACTIVE POOL ACCOUNT DETAILS : 2021-22										Upto Week - 38	As on	16.09.2022	
All figures in ₹													
Sl. No	States	Till Previous FY		CURRENT FY				Reactive Bill settelment status		Interest Bill settelment status		Reactive+Interest Settlement	
		Outstanding Payable (upto FY 20-21)	Outstanding Receivable (upto FY 20-21)	Payable to pool (2021-22)	Paid to pool (2021-22)	Receivable from pool (2021-22)	Received from pool (2021-22)	Outstanding Payable (upto FY 21-22)	Outstanding Receivable (upto FY 21-22)	O/S Reactive interest Payable till FY 20-21 2nd Half	O/S Reactive int. Receivable till FY 20-21 2nd Half	Net Outstanding Payable (upto FY 21-22)	Net Outstanding Receivable (upto FY 21-22)
0	0	1	2	3	4	5	6	1	2	7	8	0	0
1	Ar. Pradesh	-546892	161355	421170	-125722	647	-489285	0	651287	0	0	0	651288
2	Assam	-7159462	483776	57628	-7101834	510543	-11167617	0	12161935	0	0	0	12161936
3	Manipur	156043	-13944	579899	-8422	5522	-8422	744364	0	8226	0	752589	0
4	Meghalaya	0	-3763614	0	-6608926	1104187	-2659426	6608926	0	0	0	6608926	0
5	Mizoram	607867	-381974	355664	-779614	3942	-378032	1743145	0	0	0	1743145	0
6	Nagaland	-275783	64866	279802	4019	3590	-6035	0	74491	0	0	0	74490
7	Tripura	153143	31280	108	153251	65840	-583549	0	680668	0	0	0	680669
8	PSDF	0	-3646829	0	0	0	825118	0	-4471947	0	8225	0	-4463722
	TOTAL	-7065084	-7065084	1694271	-14467248	1694271	-14467248	9096435	9096435	8225	8225	9104660	9104661

Annex 6.3

अपूर्ण डीएसएम सुलह की स्थिति/ Pending DSM Reconciliation Status

SI No.	Constituents	Period Pending	Total Pending	Last Signed		
				Qr. No.	FY	Date
1	Ar. Pradesh	Up to date	0	1	22-23	17-08-2022
2	Assam	Up to date	0	1	22-23	11-07-2022
3	Manipur	22-23(Q1)	1	4	21-22	02-06-2022
4	Meghalaya	Up to date	0	1	22-23	01-08-2022
5	Mizoram	Up to date	0	1	22-23	20-07-2022
6	Nagaland	Up to date	0	1	22-23	10-08-2022
7	Tripura	Up to date	0	1	22-23	12-07-2022
8	BNC	Up to date	0	1	22-23	27-07-2022
9	Loktak	22-23(Q1)	1	4	21-22	07-06-2022
10	NEEPCo	Up to date	0	1	22-23	22-07-2022
11	OTPC	Up to date	0	1	22-23	25-07-2022
12	NTPC	Up to date	0	1	22-23	07-07-2022
			2			

अपूर्ण रिएक्टिव सुलह की स्थिति/Pending Reactive Reconciliation Status

SI No.	Constituents	Period Pending	Total Pending	Last Signed		
				Qr. No.	FY	Date
1	Ar. Pradesh	Up to date	0	1	22-23	17-08-2022
2	Assam	Up to date	0	1	22-23	18-08-2022
3	Manipur	22-23(Q1)	1	4	21-22	02-06-2022
4	Meghalaya	Up to date	0	1	22-23	01-08-2022
5	Mizoram	Up to date	0	1	22-23	01-08-2022
6	Nagaland	Up to date	0	1	22-23	10-08-2022
7	Tripura	Up to date	0	1	22-23	19-07-2022
			1			

Annexure-6.4

Case-I

2020-21 : Letter of Credit (LC) Amount against DSM charges

Figures in Rs.

Constituents	FY 20-21 DSM liability [DSM charges + Addl. DSM]	Average weekly DSM liability [A/52]	LC Amount [110% of B]	LC amt. (in Lakhs)
	A	B	C	D
AR. PRADESH	66054550	1270280	1397308	13.97
ASSAM	428038410	8231508	9054659	90.55
MANIPUR	30145186	579715	637687	6.38
MEGHALAYA	37646837	723978	796375	7.96
MIZORAM	18699967	359615	395576	3.96
NAGALAND	5587923	107460	118206	1.18
TRIPURA	61287976	1178615	1296476	12.96

Case-II

150% exceeded case of LC amount till Wk-52 of FY 2021-22

Constituents	150% of Case-I	Maximum (in a week) DSM liability of FY 21-22	Exceed of 150 % [where (B- A)>0]	Wk No of [B] where [C>0]	110% of B [where C>0]	LC to be open (in Lakhs) in FY 22-23
	A	B	C	D	E	F
AR. PRADESH	2095962	22043582	19947620	28	24247940	242.48
ASSAM	13581988	28998905	15416917	28	31898796	318.99
MANIPUR	956530	3642793	2686263	22	4007072	40.07
MEGHALAYA	1194563	7279261	6084698	31	8007187	80.07
MIZORAM	593364	4001543	3408179	2	4401697	44.02
NAGALAND	177309	6743377	6566068	29	7417715	74.18
TRIPURA	1944715	18688358	16743643	3	20557194	205.57

ANNEX 9.1

1. Historical demand/load data on hourly basis for different consumer categories viz. Domestic, Industrial, Commercial, Agriculture, etc. for the last 5 years (2017-18 to 2021-22)

Year	Time stamp	State	Consumer category wise Demand (MW)				
			Domestic	Commercial	Agriculture	Industrial	Others
2017-18	1 st April 00:00						
	1 st April 01:00						
	...						
	...						
	...						
	...						
	31 st March 22:00						
	31 st March 23:00						
2018-19	1 st April 00:00						
	1 st April 01:00						
	...						
	...						
	...						
	...						
	31 st March 22:00						
	31 st March 23:00						
...	...						
...	...						
2021-22	1 st April 00:00						
	1 st April 01:00						
	...						
	...						
	...						
	...						
	31 st March 22:00						
	31 st March 23:00						

2. Historical shifting of load from non-solar hours to solar hours-

State	Year	Load shifted to Solar Hours from non-solar Hours on annual basis(if any)			
		Agricultural	Industrial	Commercial	Others
	2016-17				
	2017-18				
	2018-19				
	2019-20				
	2020-21				
	2021-22				

3. Likely shifting of load which is envisaged from non-solar hours to solar hours in

State	Year	Load shifted to Solar Hours from non-solar Hours on annual			
		Agricultural	Industrial	Commercial	Others
State1	2022-23				
	2023-24				
	..				
	..				

Views of SLDCs/ Discoms on future load patterns (if any).

- Anticipated Changes in consumption pattern of different consumer categories in future years.
- Likely changes in the load shape for the day or month, shifting the daily peak from existing time of the day to other hours/ or likely change in peak month during the year.