



भारत सरकार Government of India

विद्युत मंत्रालय Ministry of Power

उत्तर पूर्वी क्षेत्रीय विद्युत समिति

North Eastern Regional Power Committee

एन ई आर पी सी कॉम्प्लेक्स, डोंग पारमाओ, लापालाङ, शिल्लोंग-७९३००६, मेघालय

NERPC Complex, Dong Parmaw, Lapalang, Shillong - 793006, Meghalaya



ISO 9001:2008

Ph. No: 0364 - 2534039

Fax No: 0364 - 2534040

Website: www.nerpc.nic.in

No. NERPC/SE/PCC/2017/1554-578

Dated: April 21, 2017

To,

1. Managing Director, AEGCL, Bijuli Bhawan, Guwahati – 781 001
2. Managing Director, APDCL, Bijuli Bhawan, Guwahati – 781 001
3. Managing Director, APGCL, Bijuli Bhawan, Guwahati – 781 001
4. Director (Generation), Me. PGCL, Lumjingshai, Short Round Road, Shillong – 793 001
5. Director (Distribution), Me. ECL, Lumjingshai, Short Round Road, Shillong – 793 001
6. Director(Transmission), Me. PTCL, Lumjingshai, Short Round Road, Shillong – 793 001
7. Managing Director, MSPDCL, Electricity Complex, Keishampat, Imphal – 795 001
8. Managing Director, MSPCL, Electricity Complex, Keishampat, Imphal – 795 001
9. Director (Tech), TSECL, Banamalipur, Agartala – 799 001
10. Director (Tech), TPGL, Banamalipur, Agartala – 799 001
11. Chief Engineer (WE Zone), Department of Power, Govt. of Arunachal Pradesh, Itanagar- 791111
12. Chief Engineer (EE Zone), Department of Power, Govt. of Arunachal Pradesh, Itanagar- 791111
13. Chief Engineer (TP&MZ), Department of Power, Govt. of Arunachal Pradesh, Itanagar- 791111
14. Engineer-in-Chief (P&E), Department of Power, Govt. of Mizoram, Aizawl – 796 001
15. Chief Engineer (P), Department of Power, Govt. of Nagaland, Kohima – 797 001
16. CGM, (LDC), SLDC Complex, AEGCL, Kahilipara, Guwahati-781 019
17. General Manager, TSECL, Agartala – 799 001
18. Group General Manager, NTPC, Bongaigoan Thermal Power Project, P.O. Salakati, Kokrajhar- 783369
19. General Manager (Coml.), NTPC, 3rd Floor, OLIC Bldg., Pl No- N.17/2, Nayapalli, Bhubaneswar-12
20. ED, NERTS, PGCIL, Dongtieh-Lower Nongrah, Lapalang, Shillong -793 006
21. ED (O&M), NEEPCO Ltd., Brookland Compound, Lower New Colony, Shillong-793003
22. ED (Commercial), NEEPCO Ltd., Brookland Compound, Lower New Colony, Shillong-793003
23. ED (O&M), NHPC, NHPC Office Complex, Sector-33, Faridabad, Haryana-121003
24. GM (Plant), OTPC, Badarghat Complex, Agartala, Tripura - 799014
25. GM, NERLDC, Dongtieh, Lower Nongrah, Lapalang, Shillong -793 006

Sir,

The minutes of the 46th Protection Co-ordination Committee (PCC) of NERPC held on 7th April 2017 (Friday) at Hotel Nandan, Guwahati at 10:30 hrs. is sent herewith for your kind perusal and necessary actions of all concerned.

भवदीय / Yours faithfully,

(एल. बी. मुआनथंग / L. B. Muanthang)
अधीक्षण अभियंता / Superintending Engineer

Copy to:

1. CGM, AEGCL, Bijuli Bhavan, Guwahati - 781001
2. CGM, APGCL, Bijuli Bhavan, Guwahati - 781001
3. CGM, DISCOM, Bijuli Bhavan, Guwahati - 781001
4. Head of SLDC, Me.ECL, Lumjingshai, Short Round Road, Umjarain, Shillong – 793 022
5. Head of SLDC, Department of Power, Govt. of Arunachal Pradesh, Itanagar- 791 111
6. Head of SLDC, Department of Power, Dimapur, Nagaland
7. Head of SLDC, Electricity Department, Govt. of Manipur, Keishampat, Imphal – 795 001
8. Head of SLDC, Department of Power, Govt. of Mizoram, Aizawl – 796 001
9. Head of SLDC, TSECL, Agartala – 799 001
10. Chief Engineer(Elect), Loktak HEP, Vidyut Vihar, Kom Keirap, Manipur- 795124
11. Addl. GM (O&M & Elec), NTPC Ltd., Bongaigoan Thermal Power Project, P.O. Salakati, Kokrajhar- 783369
12. DGM (C&M), OTPC, 6th Floor, A-Wing, IFCI Tower -61, Nehru Place, New Delhi – 110019.



निदेशक / Director/ SE

North Eastern Regional Power Committee

MINUTES OF THE 46TH PROTECTION COORDINATION

SUB-COMMITTEE MEETING OF NERPC

Date of Meeting : 07/04/2017 (Friday)
Time of Meeting : 10:00 hrs
Venue : “Hotel Nandan”, Guwahati.

The List of Participants in the 46th PCC Meeting is attached at **Annexure - I**.

Member Secretary, NERPC welcomed all participants and stressed the need for active participation of members from the constituents to resolve issues related to protection system in the NE region. He took thin participation of members seriously and told the forum that this issue will be taken up for discussion in the higher forum. He then asked Shri L. B. Muanthang, SE(P),NERPC to take up the agenda for discussion.

A. CONFIRMATION OF MINUTES

**CONFIRMATION OF THE MINUTES OF 45th MEETING OF PROTECTION
SUB-COMMITTEE OF NERPC**

The minutes of 45th meeting of Protection Sub-committee held on 30th November 2016 at Guwahati were circulated vide letter No. NERPC/SE/PCC/2016/3451-76 dated 9th December 2016.

As no comments/observations were received from any of the constituents, the Sub-Committee confirmed the minutes of 45th PCCM of NERPC

ITEMS FOR DISCUSSION

B1. Protection audit of Agartala, Surjamaninagar, Udaipur sub-stations of TSECL and Palatana, OTPC:

During Sub Group Committee Meeting of PCC held on 24th Oct'16, the forum decided that the Protection audit of Agartala, Surjamaninagar, Udaipur sub-stations of TSECL and Palatana, OTPC are required to be taken up urgently.

For protection audit of Agartala, Surjamaninagar, Udaipur sub-stations of TSECL and Palatana, OTPC from 7th to 9th November 2016, following members were nominated by the respective constituents:

- a. AEGCL- Ashutosh Bhattacharya, Dy. Manager (9435332928)
- b. NERTS- Deva Prasad Pal, Sr. Engineer (9435382360)
- c. NERPC- Abhijeet Agrawal, AEE (9871266951)
- d. NEEPCO- Prosenjit Sen, Sr. Manager (9436167999)
- e. OTPC- Smruti Ranjan Das, Manager (9612400784)
- f. Tripura- Mrinal Paul, Manager (9436137022)

The team had visited the substations for Protection Audit. The Audit team has observed that there are discrepancies in the OTPC protective relay settings which are in contrast with the Ramakrishna Committee Recommendations. The team recommended to OTPC to adopt the actual gradation of proper functioning of all these protective relays in coherence with the Ramakrishna Committee Recommendations.

In the 45th PCCM, OTPC representative stated that the protective settings of the ICT was as per the OEM recommendation and were not permitted to change. The Committee opined that the settings should be as per the requirements of the grid and therefore OTPC should give the audit report to OEM as a valid document to change the settings as per the requirements of the grid within 1 week.

OTPC & TSECL may please intimate the current status.

It was discussed in the **subgroup meeting held on 23rd Jan'17** that the last 3rd party Protection audit was done 4 years back. As per recommendations of Enquiry Committee, thorough third party protection audit need to be carried out in time bound manner. This exercise should be repeated periodically and monitored by RPCs. Subgroup agreed that it was necessary to carry out 3rd party protection audit at the earliest and referred the matter to PCC forum.

Deliberation of the sub-Committee:

Sr. Executive, OTPC informed the forum that OTPC has already implemented the recommendations of audit committee and submitted the report to NERPC. Forum requested subgroup to review the relay settings submitted by OTPC. Sr. Manager, TSECL informed the forum that they have implemented the recommendations for distance protection and will be implementing for other relays at the earliest. Forum requested TSECL to submit report by 30th April, 2017 to NERPC.

After detailed deliberation it was decided to carry out third party protection audit of 1/3rd of NER substation for 2017-18. Forum decided to form 8 teams with 2 members from NERPC, NERLDC, POWERGRID, NEEPCO, AEGCL, MePTCL & TSECL each and one member each from Nagaland, Mizoram, Manipur & all ISGS in NER. In POWERGRID substation audit, members from 2 states & NERLDC/NERPC shall be present. And in state substation audit, members from hosting state, POWERGRID, NERPC/NERLDC and one more state shall be present. All constituents are requested to send their nominee(s) to SE(P), NERPC before 30th April, 2017. Formation of teams, identification of stations and utility wise coordinators & preparation of audit schedule are to be completed within 30th April'17 by subgroup. Forum requested hosting station to arrange logistics, food & accommodation facilities to the audit team. Audit will be starting from May 2017.

The Sub-committee noted as above.

Action: All constituents.

B2. Identification of short lines to install line differential protection:

During Sub Group Committee Meeting of PCC held on 24th Oct'16, NERLDC informed the

forum that for purpose of installation of line differential protection on Short lines, it is necessary to identify the list of lines for this purpose.

The identification exercise for installation of Differential Protection relays has to be completed for all Transmission Lines of NER Grid level on a priority basis.

As informed by BgTPP-NTPC & POWERGRID, the installation of Differential Protection on 400 kV BgTPP – Bongaigaon D/C has been completed.

As the 1st stage, differential protection is to be installed on important short lines like 132 kV Silchar – Srikona D/C, 132 kV Imphal(PG) – Imphal(MSPCL) D/C etc.

- In 45th PCC meeting, forum decided that in the absence of uniformity of specific length criteria for installation of differential protection installation on short lines (valid for both existing and new transmission lines), the criteria adopted by SRPC could be referred for North-Eastern Region. After detailed deliberation, the following criterion was decided for adoption for identification of short line for differential protection:-
 - a) All 132 kV transmission lines of length <5 Kms.
 - b) All 220 kV transmission lines of length <10 Kms
 - c) All 400 kV transmission lines of length <50 Kms
 - d) All 132 kV & above dedicated transmission lines of Generators with installed capacity > 50 MW

The short lines as identified would be considered on basis of importance for installation of Differential Protection relays. The process of installation may be started wherever no additional investments in terms of Communication links between two ends of the line are required. Constituents of NER are requested to identify the lines in which line differential protections are to be installed under above criteria.

Deliberation of the sub-Committee:

After detailed deliberation it was decided that all constituents should identify short lines (integrated) only and submit the list of such lines to NERPC & NERLDC by 30th April, 2017. Subgroup will compile and come out with complete list of all such short line where differential protection is required by 30th April 2017. MePTCL informed that they have already identified the short lines.

After detailed deliberation, it was decided to exclude short lines that are radially connected to NER Grid from installing differential protection.

AEGCL informed that they have placed order to ABB for differential protection in line between LV side of ICT-2 at BgTPP and 220 kV BTPS bus. NTPC informed that this link shall not be treated as line as there is no 220 kV Bus at BgTPP end. Due to difference in opinion amongst AEGCL, NTPC, PGCIL and NERLDC it was decided that NERPC & NERLDC will arrange a separate meeting with AEGCL and NTPC to sort out this matter.

The Sub-committee noted as above.

Action: All constituents.

B3. Preparation of Draft model maintenance procedures that are to be followed by utilities:

During Sub Group Committee Meeting of PCC held on 24th Oct'16, it was noted that NERTS and AEGCL have already submitted their maintenance manual to the forum. SE(P), NERPC suggested that PGCIL, NERLDC and AEGCL together will prepare the guidelines for draft model maintenance procedure for transmission systems for all utilities. All constituents were requested to give their suggestions and feedback to them.

Sh. H. Talukdar, PGCIL, Sh. Jerin Jacob (Eng.NERLDC)/Rahul Chakrabarti, (Sr. Engr, NERLDC) and Sh. Ashutosh Bhattacharjee, DM, AEGCL were nominated to draft the guideline within 30th November 2016. The forum also agreed that the nominated members may call on utilities whenever needed.

In subgroup meeting held on 23rd January 17, following points were discussed:

- i. Draft Model Maintenance procedure for transmission systems is under preparation by the group. Some of the compiled parts were discussed in the meeting and many suggestions given in the meeting to be incorporated in the draft. It is expected to be finalized in the 46th PCC. Subgroup requested POWERGRID to prepare maintenance procedure for GIS, HVDC and FSC by 31st January, 2017.
- ii. It was noted that to follow the guidelines of the draft maintenance procedure, utilities may require procurement of diagnostic tools. The subgroup requested to power utilities of NER to furnish the list of diagnostics tools available with them to NERPC and NERLDC by **10th February, 2017** for further discussion. The power utilities shall inform the list of tools which are available with them. Subgroup noted that power utilities of NER may procure those tools which are not available with them from PSDF fund.
- iii. This maintenance Procedure may be referred by power utilities for their own maintenance procedure of transmission system. Power utilities will do all periodic mandated maintenance and keep the record with them which will be subject to inspections in future.

Deliberation of the sub-Committee:

After detailed deliberation it was decided that all constituents needs to give feedback on or before 30th April, 2017. After 30th April, the sub-committee will finalize the maintenance procedure. Also Forum requested all members to furnish list of plant wise available diagnostic tools to NERPC & NERLDC by 30th April 2017. MePTCL informed that they submitted the list of diagnostic tools to NERPC.

Forum also requested power utilities of NER to assess the number of new kits for measurement of tower footing resistance without the need to disconnect earth shielding wire. Possibilities of funding from PSDF for this purpose mat be explored.

The Sub-committee noted as above.

Action: All constituents.

B4. Calculation of Relay Setting as per recommendation of V. Ramakrishna task Force:

The relay settings details as formulated by NERTS in line with recommendations of V. Ramakrishna Task Force on Power system contingencies, had been circulated by NERLDC to

all constituents of NER for comments. During Sub Group Committee Meeting of PCC held on 24th Oct'16, it was agreed that the same can be implemented at the earliest for uniformity in protection systems.

In 45th PCC meeting, it was informed to the forum that Meghalaya has started the exercise while Assam has started implementing but having problem in the Resistive Reach setting and will come up with detailed analysis of the issue in the next meeting. Tripura has assured that it will start the work at the earliest. NTPC told that they can start implementing as per NERTS formulation only after receiving comments from their Corporate Office and will communicate the same to NERPC at the earliest

Deliberation of the sub-Committee:

The status is given in the table below:

Sl. No.	Constituent	Current Status of implementation	Completion Date
1.	Assam	New Substations completed. Old Substations to be completed by date	By September, 2017
2.	Arunachal Pradesh	No representative present	By September, 2017
3.	Manipur	No representative present	By September, 2017
4.	Meghalaya	Started	By September, 2017
5.	Mizoram	No representative present	By September, 2017
6.	Nagaland	Not started	By September, 2017
7.	Tripura	Completed	Completed
8.	NEEPCO	Started	By September, 2017
9.	NHPC	Completed	Completed
10.	NTPC	Started	By April, 2017
11.	OTPC	Completed	Completed

The committee requested all constituent to implement recommendation of V. Ramakrishna Task Force by September, 2017 and furnish report of the same to NERPC and NERLDC.

The Sub-committee noted as above.

Action: All constituents.

B5. Review of Zone-II relay settings:

During Sub Group Committee Meeting of PCC held on 24th Oct'16, the forum discussed the relay settings document finalised by NERTS POWERGRID for adoption in NER, for fulfilment with recommendations of V.Ramakrishna Committee Task Force. The forum had agreed for implementation of Zone-II / Zone-III settings accordingly.

NERLDC has circulated the impedances of shortest and longest lines for review of the reach of Zone-II Relay Settings by the constituents. Till now NERLDC has received comments from Assam, Meghalaya, OTPC and Kopili (NEEPCO).

Forum asked AEGCL to furnish the guidelines of Zone-2 timing followed by them at the earliest

to NERPC & NERLDC

Deliberation of the sub-Committee:

After detailed deliberation it was decided that Zone –II setting to be completed for all important lines by 30th April, 2017. Forum requested subgroup to circulate list of important lines where settings have to be implemented at the earliest.

The Sub-committee noted as above.

Action: All Constituents.

B6. Review of Earth Fault Relay settings & resistive reach of Distance Protection:

Several disturbances and major trippings in NER Grid occurred on account of fault due to vegetation etc, resulting in high-resistive faults that fall outside the characteristic of Distance Protection. In this case, Earth fault relays of faulty section should operate before Zone -2 operation of remote end.

In view of this it is proposed that the Resistive reach of Distance protection as well as settings of earth fault relays is to be reviewed by all utilities.

Deliberation of the sub-Committee:

As it is already covered under B5 the committee decided to drop the agenda item.

The Sub-committee noted as above.

Action: Agenda item may be dropped.

B7. Manual for Protection Systems:

It has been noticed that several grid events are occurring on account of different practices for protection adopted by different utilities leading to lack of co-ordination. As per Sec.7 of CEA Technical Standards for Connectivity to the Grid Regulations, 2007, utilities shall develop their own protection manuals conforming to various standards for the reference and use of its personnel.

During Sub Group Committee Meeting of PCC held on 24th Oct'16, it was noted that standard guidelines for protection system already exists. The recommendations of V. Ramakrishna Task Force Report are to be used by the utilities for all purposes.

It was also noted that CBIP has brought out an updated manual as of 2016 that contains detail guidelines for Transmission line protection. The manual was circulated to all constituents by NERLDC for reference.

The forum decided that the constituents may refer to it as guidelines for Protection systems for transmission.

In the 45th PCC meeting, the subcommittee decided that all members may refer to the CBIP manual and give comments, if any, during the next PCC meeting

Deliberation of the sub-Committee:

After detailed deliberation, the committee requested NERPC to conduct workshop regarding relay setting by PGCIL in first week of June 2017. The agenda item may be dropped.

The Sub-committee noted as above.

Action: NERTS.

B8. Review of relay settings- Substation wise (including downstream state substation):

During Sub Group Committee Meeting of PCC held on 24th Oct'16, it was informed that due to ill-coordination in relay settings between State systems and ISTS, frequent tripping of elements are occurring. Most of the Grid disturbances in NER Grid are due to this.

P&E Dept., Mizoram and DoP, Nagaland were requested to co-ordinate their relay settings with ISTS systems and implement the same as suggested by NERTS.

NERPC may take up with P&E Dept., Mizoram and DoP, Nagaland in this regard for quick implementation.

In the 45th PCCM, Chair/Sub-committee noted that whenever any state is absent in the meeting, any problem relating to the state would not be discussed as it is obvious that without their presence it is fruitless to discuss the issues related to them.

NERPC noted the absence of representatives from MSPCL, P&E Dept., Mizoram, DOP, Arunachal Pradesh and DoP, Nagaland seriously. The matter was referred to next PCC meeting.

Decision taken in sub group meeting held at Shillong on 24.10.16 are to be implemented at the earliest and status to be reported to NERPC&NERLDC.

Deliberation of the sub-Committee:

EE, DoP Nagaland informed the forum that they will discuss with POWERGRID and implement the required relay settings in downstream elements of DoP, Nagaland within 1 month to avoid unnecessary tripping of ISTS lines due to downstream fault.

The Sub-committee noted as above.

Action: DoP Nagaland.

B9. Details of PSS installed and activated in all Hydro stations:

During Sub Group Committee Meeting of PCC held on 24th Oct'16, NERLDC requested all power stations to provide details where PSS is installed. It was also requested to activate existing PSS after tuning and inform the same through mail.

NEEPCO vide mail dtd. 27th Oct'16 informed that all hydro stations of NEEPCO have PSS installed and activated. NERLDC vide email dtd. 27th Oct'16 had requested NEEPCO for further details of PSS.

NERLDC requested NEEPCO and NHPC to furnish details and settings of existing PSS (Time constant, PSS gain, PSS output limiter Max, Min etc.).

Only Palatana CCGT has provided the details of PSS installed and activated for damping

oscillations to NERLDC, whereas the details provided by NEEPCO is not sufficient and to be submitted to NERPC/NERLDC. NEEPCO has given parameters of block diagram of some of their generators (Khandong, etc.), which do not convey any practical meaning in sense of damping of Low Frequency Oscillations. NERLDC requested NEEPCO to furnish the following details of PSS – Make, Date installed, Last date of tuning by OEM, Tuned frequency range.

In the 45th PCCM, NERLDC expressed concern in the matter of several cases of Poorly Damped/Negatively Damped Oscillations in Southern part of NER Grid, and requested NHPC to tune their PSS if it is already installed, and furnish details of PSS to NERPC&NERLDC.

Deliberation of the sub-Committee:

The committee requested NEEPCO to provide the necessary details to NERLDC at the earliest. NERLDC requested NHPC to install PSS for the betterment of system. Manager, NHPC informed that PSS is not installed in Loktak generating station.

The Sub-committee noted as above.

Action: NEEPCO.

B10. Standardization of Disturbance Recorder Channels:

Disturbance Recorders on Transmission elements are necessary for post disturbance analysis, and identification & rectification of any protection operation. As per CBIP's manual on Protection of Generators, GT, Transformers and Networks, it is recommended to have minimum 8(eight) analog signals and 16(sixteen) binary signals per bay or circuit. Also, it should have a minimum of 5 sec of total recording time, minimum pre-fault recording time of 100 msec and minimum post-fault recording time of 1000 msec.

POWERGRID had standardized Disturbance Recorder Channels for lines, transformers & reactors. The Sub-committee requested NERPC/NERLDC to circulate the above standardization to all constituents of NER for giving comments and suggestion by 24.07.15. NERLDC had sent this document to all constituents of NER for giving comments and suggestion by 24.07.15.

During 42nd PCC meeting, the forum requested NTPC to provide their standardized DR Channels for generator so that it may be standardized for all generating units of NER. NTPC representative readily agreed. S.E. (O) once again requested all the constituents to kindly furnish their comments so that the process may be completed.

During the 43rd PCCM, DGM (SO-II), NERLDC stated since no comments/observations were received from the constituents it may be assumed that the DR channels for line, transformer and reactor are finalized. After detailed deliberation, forum decided DR channels as finalized have to be implemented in all ISTS lines and intra-state lines with numerical relays, within 31.07.2016 and gradually for all 220kV and 132kV lines.

The forum agreed that since Assam system is the largest state system of NER Grid, standardization of DR channels in lines of Assam is felt necessary. It was decided that Assam may complete implementation of standardized DR channels by 31st August 2016, and take help from NERTS if necessary.

NTPC agreed to submit standardized DR channels for generator by 20.07.2016, which can then be discussed for adoption by all generators of NER Grid.

In 44th PCCM, AEGCL representative informed the forum that the work of DR standardization will be completed by 30th November 2016.

Deliberation of the sub-Committee:

AGM, AEGCL informed that they have already standardized DR channels for all 200KV and above lines. OTPC, Tripura has not done yet. NERLDC informed forum that after repeated request to OTPC, their DR digital channels are not standardized, so proper analysis of events related to Palatana could not be done. OTPC informed that they will look in-to this matter at the earliest. TSECL informed that they have not done the DR standardization. The forum requested NERLDC to provide list of all lines where standardization of DR Channel is required. All members are requested to provide update of Standardization of channel to NERLDC at the earliest.

The Sub-committee noted as above.

Action: All Constituents.

B11. Proposed SPS to prevent Palatana ICT over loading:

Supply of additional 100MW power tied up by Govt. of India for Bangladesh is likely to start December end. At that stage Tripura will draw power from 132KV Palatana-Suryamani Nagar line around 200 MW to maintain 200MW Power flow from Suryamani Nagar to Comila sub-station.

As per rated capacity of 125 MVA ICT, 100 MW of power may be evacuated safely through each ICT. With our both 125 MVA ICTs in service, TSECL may draw power safely to a maximum of 200 MW through Palatana-SM Nagar 132KV Line, excluding our station auxiliary power and ICT losses. During power flow of 200 MW through 132 kV line, if one of our ICT trips then the other ICT would get overloaded due to flow of 200 MW through single ICT and would ultimately lead to tripping of other ICT also. Tripping of both ICTs would lead to sudden load through off of 200 MW, which would trip subsequent feeders in cascading effect. This tripping would disturb our station auxiliary power requirement from 132 kV side and would result in tripping of both Units of OTPC, Palatana. This cascading effect may lead to a major Grid disturbance and Grid blackout condition.

Considering the above facts and to avoid over loading of second ICT in the event of tripping of one ICT a **system protection scheme (SPS)** is proposed to trip the 132 KV line (Palatana-Surjamaninagar) at the time of tripping of one ICT to prevent overloading of other ICT.

The proposed scheme was also discussed with third party protection audit team during visit at our plant site on 09.11.2016 for protection audit.

PROPOSED PHILOSOPHY

1. This Scheme will trip 132 kV line (Palatana-Surjamaninagar) to prevent overloading and tripping of surviving ICT if one ICT trips and total power flow at that time through surviving ICT is more than 130 MW. The Trip signal will be generated by executing algorithm in DCS to trip the Palatana-SM Nagar 132KV line.

Proposed Scheme

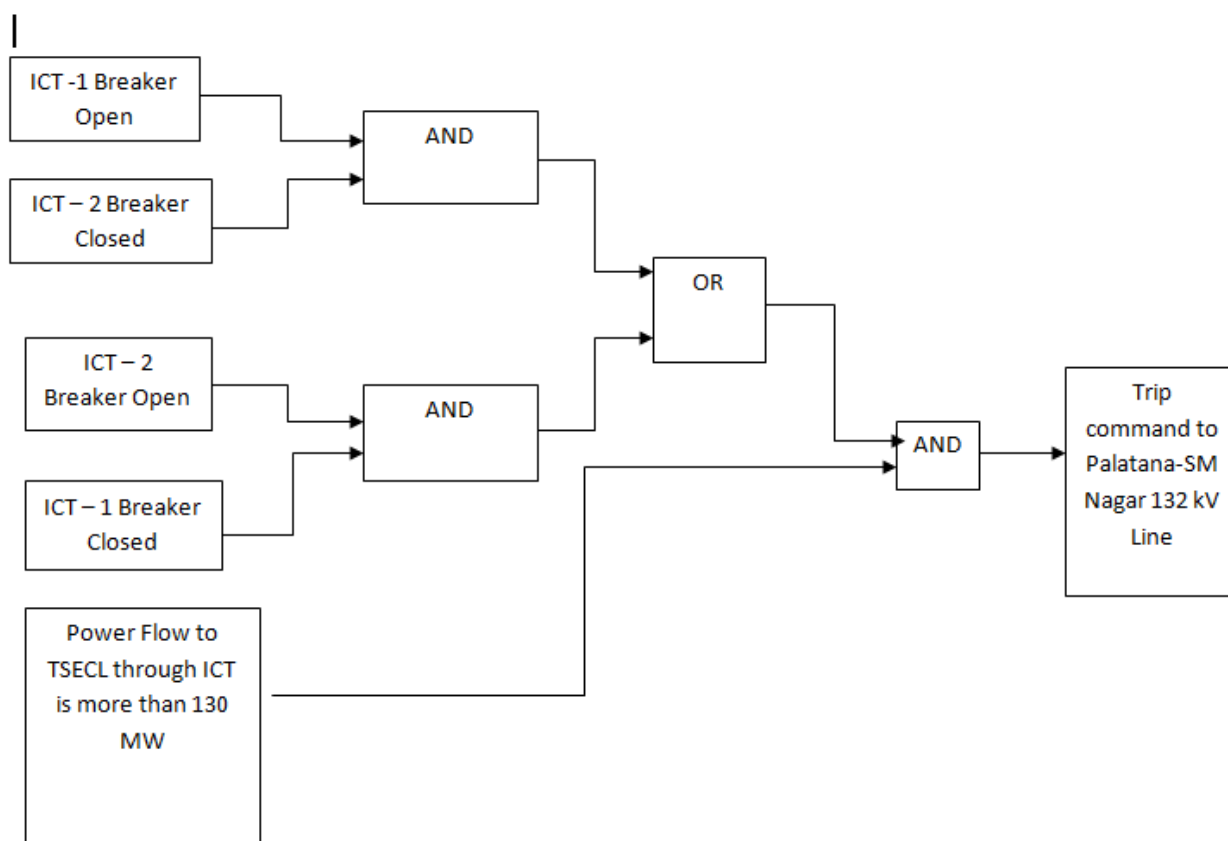

Deliberation of the sub-Committee:

NERLDC informed that the scheme proposed by OTPC is not feasible as the tripping of 132 kV Palatana - Surajmaninagar line will result in overloading of 132 kV lines in Tripura system and this will cause collapse of entire Tripura system with Bangladesh, Monarchak & AGTPP systems. NERLDC informed the forum that only solution is the instant load shedding of around 60 MW in Tripura system. Forum requested TSECL to identify loads that are to be disconnected instantly, within 1 week and inform NERPC & NERLDC for further proceedings.

Meanwhile the forum decided to refer the agenda item to OCC as there is another similar SPS of OTPC under discussion in OCC.

The Sub-committee noted as above.

Action: TSECL.

B12. Review of Recommendations of Empowered Committee for Analysis of GD-V and GD-IV in NER:

- During Sub Group Committee Meeting of PCC held on 24th Oct'16, NERLDC indicated that SPAR (Single Phase Auto Reclosure) is not available in 132 kV AGTPP – Agartala D/C lines, which was resulting in multiple tripping of these lines on transient fault. NERTS was requested for changing of Auto-reclosure scheme to SPAR.

It was also decided that utilities should identify those transmission lines which have no SPAR scheme for implementation of the same. Implementation of SPAR is considered necessary in view of reliability of the power system.

In 45th PCCM, Forum requested all constituents to furnish status report of SPAR

implementation to NERPC.

- It was noted that most of trippings of transmission lines in NER Grid occur either on account of lightning strikes or due to vegetation infringement problem. It was decided that all utilities will identify the lightning prone areas and conduct checking of high tower footing resistance in transmission lines in these areas.

Since tripping of line on lightning occurs due to arcing, to prevent that it is required to either maintain low value of tower footing resistance or go for installation of lightning arrester for the particular towers having consistent high tower footing resistance due to prevailing ground conditions.

In 45th PCCM, The forum requested all the constituents to complete the process of identification of lightning prone line sections, and initiate action in this regard.

- For purpose of information regarding furnishing of communication outage during Grid disturbance of Category-V in NER, NERLDC had circulated a format as finalized by NLDC. However, till date information has been received only from SLDC-Mizoram, SLDC-Meghalaya, Ranganadi HEP.

NERLDC had followed up with constituents vide reminder emails dated 26th Oct'16, 01st Nov'16, 21st Nov'16. The information is being sought to solve the matter of telemetry unavailability in real-time SLDC-Mizoram, SLDC-Meghalaya, Ranganadi HEP during Grid Disturbances, which delay the restoration time.

In 45th PCCM, The subcommittee requested all constituents to submit data of communication outage during GD-V to furnish data within 1 week to NERLDC as per format.

Deliberation of the sub-Committee:

Forum requested subgroup to circulate list of important lines to get the latest information regarding implementation of 1-phase/3-phase Auto-Reclosure scheme. All members to furnish the required information to NERLDC & NERPC by 30th April'17.

Forum requested members to identify lightning prone areas and measure tower footing resistance in these locations. AEGCL & MePTCL informed that they don't have proper earth resistance measuring tool at present and they are planning to procure the same at the earliest. POWERGRID informed that additional shield wire earthing and counterpoise earthing are not helping much to arrest lightning. Better way is to install TLSA as chemical earthing cost (around RS. 80,000) is double the cost of installation of TLSA (around RS. 40,000).

NERLDC informed after major disturbances, SCADA data from many of the states & ISGS are not available at NERLDC. Forum requested SCADA personnel to check healthiness of DC supply & link and requested NERLDC to coordinate this exercise.

The Sub-committee noted as above.

Action: TSECL.

B13. Analysis & Discussion on Events, Grid Incidences, Grid Disturbances which occurred in NER Grid w.e.f November'16- February'17.

The following numbers of Grid Disturbances (GD) & Grid Incidents (GI) occurred during the period **w.e.f 1st November, 2016 to 28th February, 2017 :-**

Sl No	Control Area	GI	GD	GI	GD	GI	GD
		Nov-Dec'16	Nov-Dec'16	Jan-Dec'16	Jan-Dec'16	Jan-Feb'17	Jan-Feb'17
1	Palatana	2	0	17	3	11	0
2	AGBPP	6	0	30	2	3	0
3	AGTPP	4	1	34	6	5	1
4	Ranganadi	1	0	2	2	0	0
5	Kopili	1	0	5	2	2	0
6	Khandong	1	0	7	2	0	0
7	Doyang	1	0	4	6	0	0
8	Loktak	1	0	3	3	0	0
9	BgTPP	2	0	9	2	5	0
10	Arunachal Pradesh	0	6	0	51	0	5
11	Assam	0	7	0	55	0	3
12	Manipur	0	5	0	57	0	7
13	Meghalaya	0	0	0	69	0	2
14	Mizoram	0	0	0	24	0	3
15	Nagaland	0	5	0	68	0	1
16	Tripura	0	1	0	7	0	1

Sl . No.	Category of GD/GI	Grid Disturbance in nos		
		Nov-Dec'16	Jan-Dec'16	Jan-Feb'17
1	GI-I	7	51	5
2	GI-II	12	59	21
3	GD I	25	295	21
4	GD II	1	5	0

5	GD III	0	0	0
6	GD IV	0	0	0
7	GD V	0	1	0
8	Total GI	19	110	26
9	Total GD	26	301	21

This is for information to the members.

The root cause analysis and remedial measures to prevent the Grid Events were discussed during meetings of Sub-group of PCC held on 23rd January & 9th March 2017.

Remedial Measures suggested by subgroup are to be implemented by the concerned power utilities of NER within stipulated time. Remedial Measures suggested by subgroup are attached as Annexure I.

Important events are listed below:

I. Disturbance in Tripura System:

- A.** Tripura System (except Northern part) including Bangladesh Load, AGTPP system and Monarchak system was connected with rest of NER Grid through 132 kV AGTPP-Kumarghat, 132 kV Baramura-Jirania line & 132 kV Palatana-Surjamaninagar line (**132 kV Agartala-Dhalabil line was under shut down since 18:17 Hr on 19.12.2016 and 132 kV Palatana-Udaipur line and 66 kV Gumti- Amarpur lines kept open for system requirement**).

At 15:33 Hr on 20.12.16, **132 kV AGTPP-Kumarghat, 132 kV Baramura-Jirania line & 132 kV Palatana-Surjamaninagar line tripped**. Due to tripping of these elements, Tripura System (except Northern part) including Bangladesh load (68 MW), AGTPP system, Monarchak system and Rokhia system was separated from rest of NER Grid. Bangladesh load fed from Surajmaninagar substation was connected through 132 kV Agartala-Surajmaninagar I (132 kV Agartala-Surajmaninagar II, 132 kV Budhjangnagar-Surajmaninagar I & II kept open for system requirement).

Due to tripping of 132 kV Agartala-Surajmaninagar I, there was disturbance in Bangladesh. AGTPP Unit I & II, Rokhia Unit 7 & 8 was serving load of around 85 MW. Isolated portion was synchronised through 132 kV Baramura- Jirania Line at 1611 Hrs. 132 kV Bus coupler at Palatana was also tripped during the disturbance.

In subgroup meeting on 23rd Jan'17, POWERGRID informed that relay (7SA513) at 132 kV AGTPP- Kumarghat line relay hanged and did not operate causing other trippings. The transient fault was also cleared gradually. Root cause could not be concluded as this event includes trippings in Tripura system.

- B.** Tripura System except Udaipur area & P.K Bari area (P.K Bari, Dharmanagar, Kailashahar, Ambasa, Kamalpur) along with AGTPP Power Station and Bangladesh System (South Comilla load) were connected with rest of NER Grid through 132 kV Kamalpur-Dhalabil line, 132 kV Monarchak- Rokhia line & 132 kV AGTPP-Kumarghat line (**132 kV Palatana-Surjamaninagar line was under planned shutdown from 09:09 Hrs on 25/02/17, 132 kV Ambassa-Gamatilla line was under shutdown from 09:06 on 25/02/17**).

At 10:21 Hr on 25/02/17, 132 kV Kamalpur-Dhalabil line, 132 kV Monarchak- Rokhia line & 132 kV AGTPP-Kumarghat line tripped.

Due to tripping of these elements, Tripura System except Udaipur area & P.K Bari area (P.K Bari, Dharmanagar, Kailashahar, Ambasa, Kamalpur) along with AGTPP Power

Station and Bangladesh System (South Comilla load) were separated from rest of NER Grid and subsequently collapsed due to load generation mismatch.

Subgroup referred this matter to next PCCM as this event involves tripping in Tripura System.

- C. At 13:54 Hr on 20.03.17, **400 kV Silchar-Palatana D/C lines, 132 kV Agartala-Kumarghat line, 132 kV SM Nagar-Palatana line, 132 kV Palatana-Udaipur line, 132 kV Dhalabill-Agtartala line, 132 kV Gamaitilla-Ambassa line & 132 kV Gamaitilla- Baramura lines** tripped.

Due to tripping of these elements, Tripura System except P.K Bari area along with AGTPP Power Station, Palatana Power Station and Bangladesh System (South Comilla load) were separated from rest of NER Grid and subsequently collapsed due to load generation mismatch.

II. Substation Blackouts:

A. Jiribam(PG)

At 09:39 Hr on 25.12.16, **132 kV Jiribam - Aizwal, 132 kV Loktak - Jiribam(PG), 132 kV Badarpur - Jiribam and 132 kV Haflong(PG) - Jiribam lines** tripped.

Due to tripping of these elements, Jiribam area was separated from rest of NER Grid and subsequently collapsed due to no source in this area.

In subgroup meeting on 23rd Jan'17, POWERGRID informed **earth switch** was connected to live 132 kV Jiribam- Loktak line by **bypassing interlock** led to bus fault at Jribam end. This led to tripping of other connected lines.

B. Kumarghat (PG)

At 16:02 Hrs on 13.01.17, **132 kV Badarpur – Kumarghat line, 132 kV Aizawl – Kumarghat line, 132 kV P K Bari - Kumarghat line, 132 kV AGTPP – Kumarghat line** tripped.

Due to tripping of these elements, Kumarghat(PG) was blacked out.

In subgroup meeting on 9th March'17, POWERGRID informed Bus fault occurred due to accidental closing of transfer isolator for conducting NTAMC Works which **was earthed**.

C. Imphal(PG)

At 10:05 Hr on 03-02-2017, **132 kV Imphal-Imphal I & II lines, 132 kV Dimapur – Imphal line, 132 kV Loktak - Imphal (PG) line, 132 kV Silchar - Imphal (PG) I&II lines** tripped.

Due to tripping of these elements, Capital area & Karong area were separated from rest of NER Grid and subsequently collapsed due to no source in this area.

In subgroup meeting on 9th March'17, POWERGRID informed Bus fault occurred due to accidental closing of transfer isolator for conducting NTAMC Works which was earthed.

In subgroup meeting on 9th March'17, POWERGRID informed that delayed clearance of fault in the manipur system due to **33 kV Cable & Bus PT blast** led to tripping of all feeders of Imphal(PG) from remote end. Due to absence of Impedence relay at Imphal(PG) for Imphal(MA) feeders led to Zone-3 fault clearance.

D. Mariani (PG)

1. Mariani(PG) substation was connected with rest of NER Grid through **220 kV Mariani(PG) - Misa, 220 kV Mariani(PG) - Mokokchung (PG) I & 220 kV AGBPP - Mariani(PG) lines (Mariani(PG) - Mokokchung (PG) II line kept open for system constraint from 21:06 Hrs of 19.02.17)**.

At 05:00 Hr on 22/02/17, 220 kV Mariani(PG) - Misa, 220 kV Mariani(PG) - Mokokchung (PG) I & 220 kV AGBPP - Mariani(PG) lines tripped.

Due to tripping of these elements, Mariani(PG) substation was blacked out.

2. Mariani(PG) substation was connected with rest of NER Grid through **220 kV Mariani(PG) - Misa, 220 kV Mariani(PG) - Mokokchung (PG) I (220 kV AGBPP - Mariani(PG) was not restored after tripping at 22nd Feb 2017 at 05:00 Hr and Mariani(PG) - Mokokchung (PG) II line kept open for system constraint from 21:06 Hrs of 19.02.17).**

At 05:46 Hr on 22/02/17, 220 kV Mariani(PG) - Misa & 220 kV Mariani(PG) - Mokokchung (PG) I lines tripped.

Due to tripping of these elements, Mariani(PG) substation was blacked out.

In subgroup meeting on 9th March'17, after detailed deliberation it was concluded that due to mal-operation of Over Voltage relay at Mariani (PG) led to these events. Subgroup requested POWERGRID to check over voltage relay settings, Relay time synchronization and CVTs.

III. Disturbances in Mizoram System:

Mizoram system (Zuangtui area, Luangmual area and Kolasib area) was connected with rest of NER Grid through 132 kV Aizawl- Jiribam line & 132 kV Kolasib-Badarpur line (**132 kV Aizwal-Kumarghat line was under shutdown from 07:56 Hrs of 24.02.17 for replacement of all existing insulators with polymer composite long rod insulators).**

At 14:58:58.240 Hrs on 27.02.2017, **132 kV Aizawl- Jiribam line & 132 kV Kolasib-Badarpur line** tripped.

Due to tripping of these elements, Mizoram system was separated from rest of NER Grid and subsequently collapsed due to no source in this area.

In subgroup meeting on 9th March'17, POWERGRID informed that fault was in 132 kV Badarpur - Kolasib 1 Line due to fire. Due to non operation of Siemens relay at 7SA513 relay at Kolasib end of 132 kV Badarpur - Kolasib 1 Line, fault was cleared from Jiribam end in Zone-3.

Subgroup requested POWERGRID to rectify problems of relays at Kolasib & Aizwal bays of 132 kV Badarpur - Kolasib 1 Line and 132 kV Aizwal - Kolasib Line respectively and furnish patrolling report and detailed report of the event to NERLDC & NERPC.

Deliberation of the sub-Committee:

Representative of TSECL was not associated with protection related matters. So disturbances related to Tripura system could not be discussed.

Forum requested subgroup to analyze the disturbance associated with Palatana system on 20th march'17.

After detailed deliberation, it was decided that grid disturbances which are of critical nature and grid disturbances affecting southern part of NER grid are to be analyzed immediately by subgroup.

The Sub-committee noted as above.

Action: All Constituents.

B14. Analysis of transmission element tripping in the month of November'16 to February'17:

The tripping of transmission elements and generating units of NER Grid were discussed during the Meetings of Sub-group of PCC on 23rd January'17 & 9th March'17.

The remedial measures as indicates need to be implemented by the utilities at the earliest. Remedial measures to be implemented are attached as Annexure I.

During analysis of the Grid Events, lack of information like relay indications, Disturbance Recorders etc. lead to inconclusive analysis. It has been found that the NEEPCO stations except Khandong have repeatedly failed to furnish the DR outputs. Also, Dimapur(PG), Balipara(PG) for 132 kV Balipara – Khupi line do not furnish the DR outputs in case of events. Also, DR from Assam and Imphal(PG) for Imphal(MA) feeders are not furnished in most of the disturbances.

Deliberation of the sub-Committee:

DGM, NERTS requested NERLDC to provide summary of analysis and remedial measures instead of such long annexure. After detailed deliberation the forum decided that NERLDC will provide a concise summary of analysis and remedial measures along with detailed analysis.

The Sub-committee noted as above.

Action: NERLDC.

B15. Severe Oscillation on +/- 800 kV HVDC Biswanath Chariali (NER) – Agra (NR) Bipole:

On 15th December'16 w.e.f. 1340 Hrs to 1345 Hrs, severe oscillation was observed on +/- 800 kV HVDC Biswanath Chariali (NER) – Agra (NR) link while under Bipolar operation in Current Control mode from Agra to Biswanath-Chariali.

During the period, flow on HVDC BiswanathChariali-Agra Pole-II was found to vary by about 200 MW, causing fluctuations in line flows at 400 kV Bongaigaon - Balipara line of nearly 100 MW / circuit. Oscillation of nearly 20 kV in voltage at 400kV Balipara, and nearly 0.4 Hz in frequency at Balipara was observed.

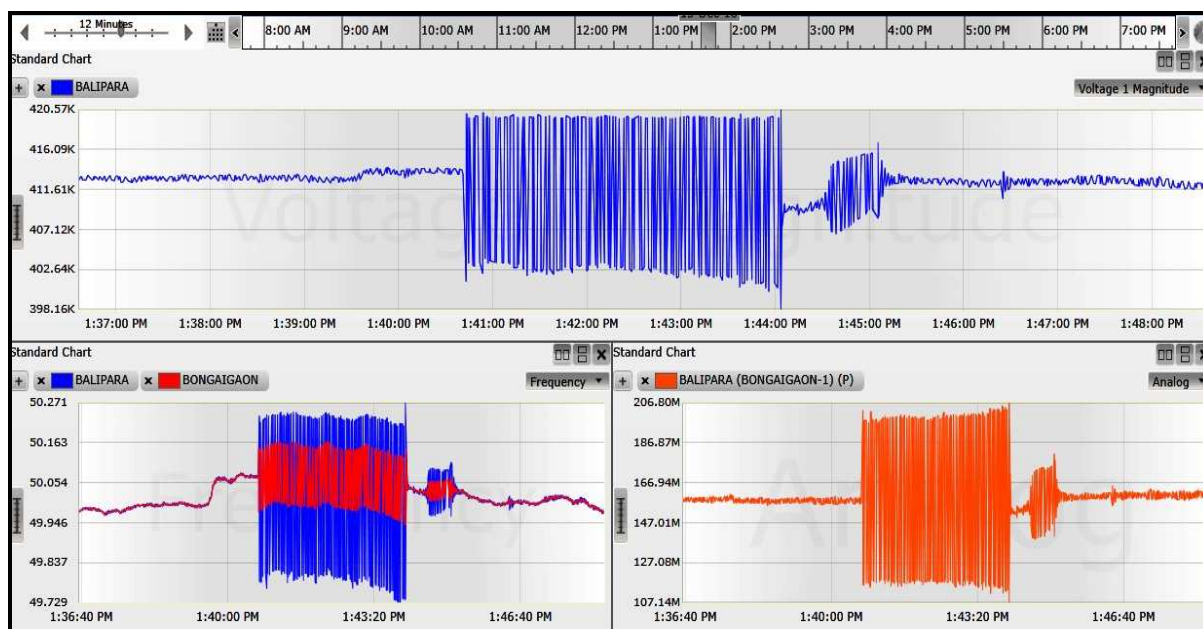

Information was requested from BNC vide emails from NERLDC dated 15th Dec, 18th Dec and 28th Dec'16.

Similarly on 05th January'17 at around 11:39 Hrs, oscillations have been recorded in active power at the time of deblocking of +/-800 kV HVDC BNC Agra for around 45 seconds. Pole-I was blocked at 1252 hrs on 05th January'17.

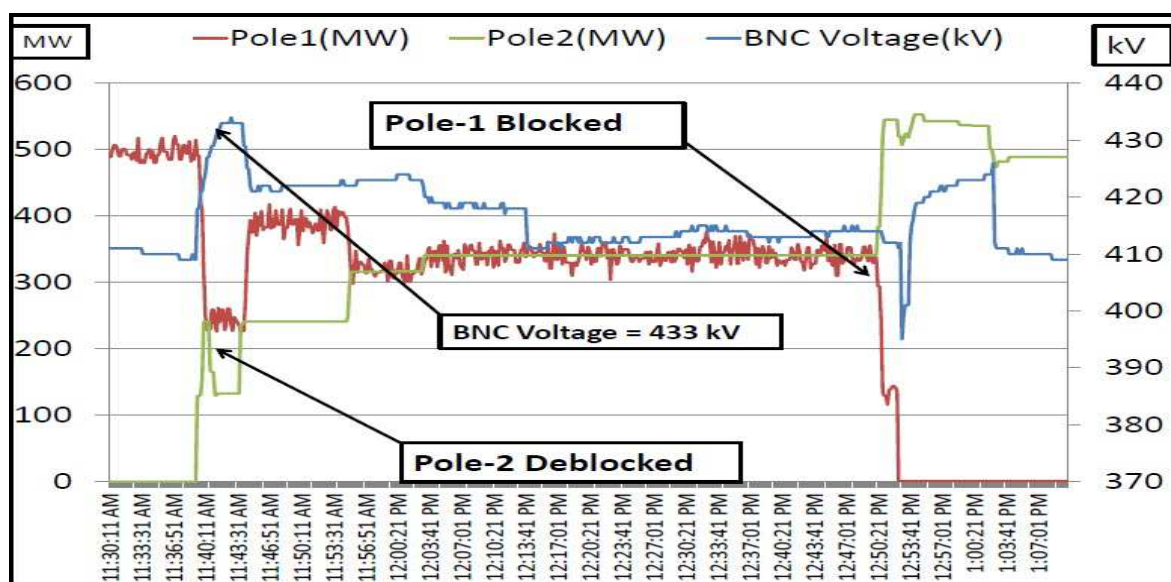

HVDC BNC was requested to submit report in respect of these 2 occasions, citing root cause, remedial measures taken, Sequence of events, etc. to enable secure operation of interconnected grid.

In spite of multiple follow-up with HVDC Biswanath Chariali for looking into the matter of oscillation, there has been no response. Also, in matters of Grid events, response from HVDC Biswanath Chariali has not been forthcoming, which is detrimental for integrated power system operation.

This issue was discussed in 128th OCCM and referred to next PCCM.

Deliberation of the sub-Committee:

NERLDC requested POWERGRID to provide the required data as well as detailed report at the earliest. DGM, POWERGRID assured the forum that the data will be made available at the earliest.

The Sub-committee noted as above.

Action: NERTS, NERLDC.

B16. Low Frequency Oscillations (LFOs) at 132 kV Agartala:

There have been several instances of Low Frequency oscillations as observed from PMU at 132 kV Agartala in the period from 1st October'16 to 11th January'17.

One third of NER generation is around Agartala area with nearby gas-based generation plants at Palatana CCGT (726 MW), AGTP-CC (130 MW), Monarchak GBP (101 MW), Rokhia GBP (63 MW) and Baramura GBP (42 MW).

<i>Oscillation log from October'16 to December'16</i>					
<i>Sl.No.</i>	<i>Date</i>	<i>Starting Time</i>	<i>Duration</i>	<i>Mode of LFO</i>	<i>Remarks</i>
1	10-Oct-16	17:28 Hrs	39 Hrs	0.4 Hz	-
2	04-Dec-16	22:11 Hrs	20 Hrs	0.4 Hz	-
3	08-Dec-16	09:20 Hrs	10 Hrs	0.3 Hz	Oscillation during switching of Desynchronisation of AGTPP U#2

					due to abnormality in fan
4	03-Jan-17	07:43 Hrs	3 Hrs	0.4 Hz	Oscillations started with tripping of AGTPP GT # 4
5	10-Jan-17	22:04 Hrs			At the same block (22:00 Hrs-22:15 Hrs), Kopili schedule was charged from 187 MW to 141 MW

On 3 particular instances, oscillations have been traced to have originated on account of switching events at AGTPP-CC of NEEPCO.

On 08th December'16 from 09:20 Hrs onwards, oscillation was seen prominently in Voltage at 132 kV Agartala PMU. No significant oscillation was observed in Active power / Frequency. In line current on 132 kV AGTPP – Agartala I line, an oscillation of nearly 5-6 A in magnitude was observed.

Upon investigation with data from PMU and SCADA-Sequence of Events, it was found that the oscillations started with Desynchronisation of AGTPP GT # 2.

Considering the oscillation in voltage and request from AGTPP in real time to control voltage (though 132 kV Agartala voltage was around 136 kV, which is well within permissible voltage limits), it is suspected that oscillations occurred due to contribution of Automatic Voltage Regulator (AVR) of AGTPP units.

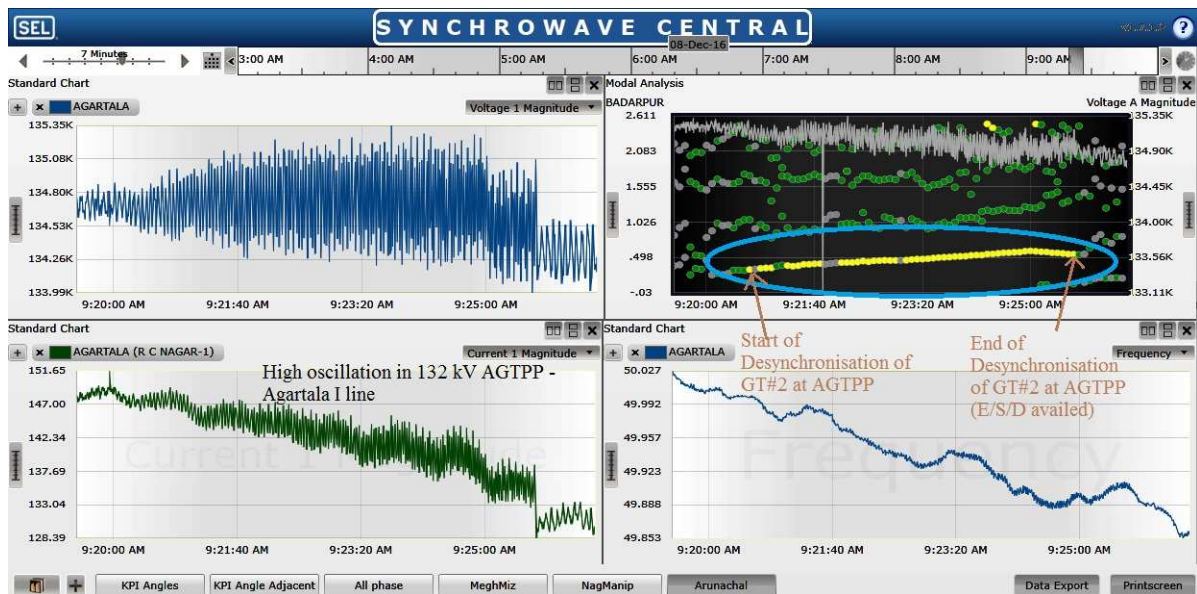

On 03rd January'17 from 07:43 Hrs onwards, oscillation was seen prominently in Voltage, at 132 kV Agartala PMU for a long duration of around 3 Hours.

Upon investigation, it was found that the oscillations started with tripping of AGTPP GT # 4. Considering that the mode of oscillation and nature of trigger was the same, it is also suspected due to action of AVR of the in-service AGTPP units.

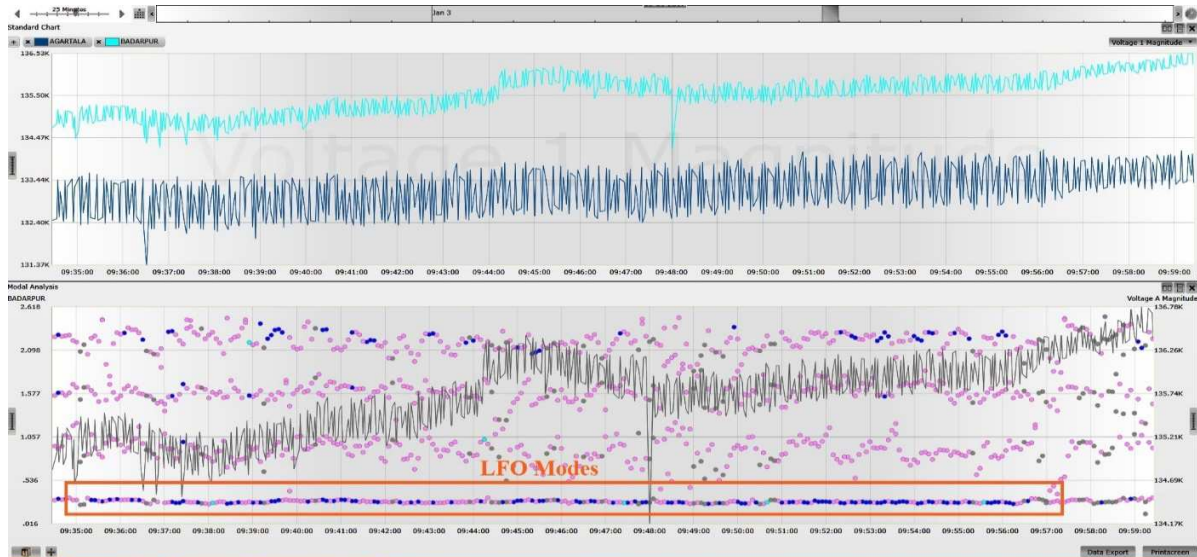

On 10th January'17 from 22:04 Hrs onwards, oscillation was seen prominently in Voltage, at 132 kV Agartala PMU.

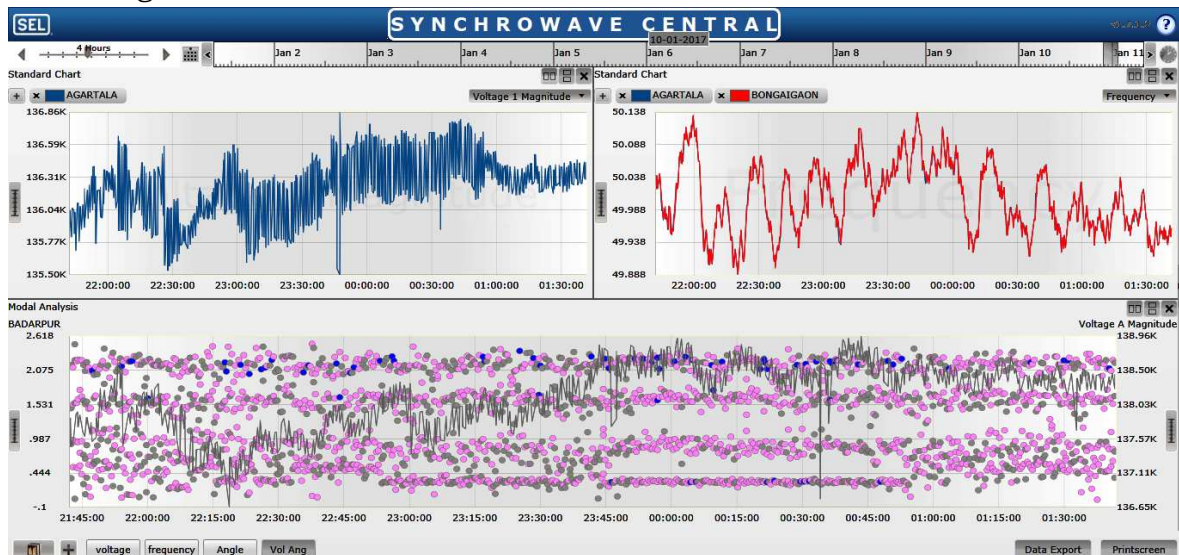

On 11th January'17 from 23:23 Hrs onwards, oscillation was seen prominently in Voltage, at 132 kV Agartala PMU.

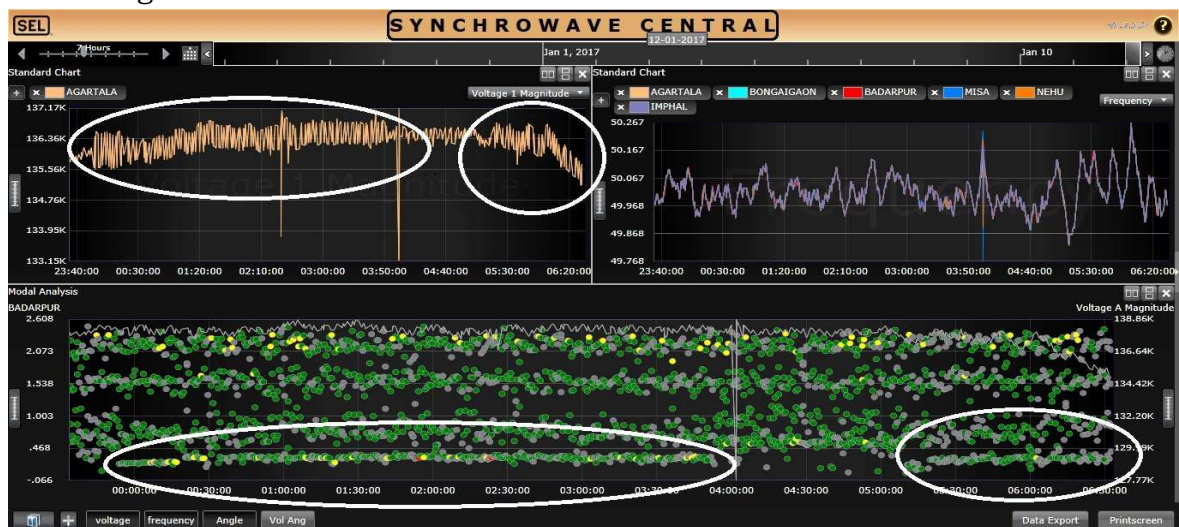

This issue was discussed in 128th OCCM and referred to next PCCM.

In **subgroup meeting held on 9th March 2017**, NERLDC showed the PMU plots of several instances of oscillations observed at 132 kV Agartala PMU and raised concern on proper tuning of Automatic Voltage Regulator (AVR) of AGTTP units considering the oscillation in voltage and many of the cases involved switching of AGTTP units. He also requested NEEPCO to take this matter seriously as these localized oscillations can spread to other generating stations connected to grid.

Sr. Manager, NEEPCO informed that there was a change in control systems of AGTTP Units 3 & 4. OEM has informed them that oscillation may be due to change in control system as oscillations were observed only in these units. He also informed that control systems of AGTTP Units 1 & 2 will be replaced soon with new ones. If those machines also experience oscillation problem, OEM will install additional equipment to damp the oscillation.

DGM (SO-II), NERLDC asked NEEPCO to check and inform forum whether PSS is enabled and functioning properly. He also requested NEEPCO to carry out AVR tuning and take necessary actions to damp out oscillations at the earliest as these oscillations can lead to wide spread oscillations in grid.

Deliberation of the sub-Committee:

Sr. Manager, NEEPCO informed that the oscillation started after changing the control panel of units 1 and 2. NEEPCO also informed that matter is already reported to OEM and OEM is yet to provide any solution. The forum requested NEEPCO to pursue the matter very seriously with the OEM as low frequency oscillation endangers the stability of grid and come up with solution at the earliest.

The Sub-committee noted as above.

Action: NEEPCO.

Any other item:

Date and Venue of next PCC

It is proposed to hold the 47th PCC meeting of NERPC on second week of June, 2017. The exact venue will be intimated in due course.

List of Participants in the 46th PCC Meetings held on 07/04/2017

SN	Name & Designation	Organization	Contact No.
1.	Sh. Ashutosh Bhattacharya, DM(AEGCL)	Assam	09435332928
2.	Sh. Chandan Sharma, DGM (Protection)	Assam	09864150106
3.	Sh. Bikram Bordoloi, DM	Assam	09435558545
4.	Sh. A. G. Thum, AEE, MePTCL	Meghalaya	09774664034
5.	Sh. B. Nikhla, EE, MePTCL	Meghalaya	09436314163
6.	Sh. H. F. Shongpliong, SE, MePTCL	Meghalaya	09863315562
7.	Sh. K. Lyngwa, EE	Meghalaya	09402506948
8.	Sh. W. Khyriem, EE(GSPD)	Meghalaya	09856007107
9.	Sh. Mhonlumo Kikon, EE(Trans) MKG.	Nagaland	09436005616
10.	Sh. Rokobeito Iralu, SDO(Trans)	Nagaland	09436832020
11.	Sh. Sankar Chawdhuri, Sr. Manager	Tripura	09436503239
12.	Sh. Amaresh Mallick, DGM(SO-II)	NERLDC	09436302220
13.	Sh. Jerin Jacob, Engineer	NERLDC	09402120113
14.	Sh. Krishna Kant Rai, Dy. Manager	NEEPCO	09436581230
15.	Sh. Dinabandhu Baishya, Sr. Mngr (E/M)	NEEPCO	09435339966
16.	Sh. P. Kanungo, DGM	PGCIL	09436302823
17.	Sh. Alokesh Hazarika, Sr. Executive	OTPC	07085060480
18.	Sh. Jagdish Prasad, Manager(E)	NHPC	09971316874
19.	Sh. J. Bhattacharyya, AGM(EM)	NTPC	09435720036
20.	Sh. P.K. Mishra, MS	NERPC	09436591068
21.	Sh. L. B. Muanthang, SE	NERPC	09436731488
22.	Sh. P. N. Sarkar, EE	NERPC	09830027523
23.	Sh. Sadiq Imam, AD-I/AEE	NERPC	07004133772