



भारत सरकार Government of India

विद्युत मंत्रालय Ministry of Power

उत्तर पूर्वी क्षेत्रीय विद्युत समिति

**North Eastern Regional Power Committee**

एन ई आर पी सी कॉम्प्लेक्स, डोंग पारमाओ, लापालाङ, शिल्लोंग-७९३००६, मेघालय  
NERPC Complex, Dong Parmaw, Lapalang, Shillong - 793006, Meghalaya

Ph. No: 0364 - 2534039

Fax No: 0364 - 2534040

Website: www.nerpc.nic.in

No. NERPC/SE (O)/OCC/2019/ **1354-1391**

Dated: June 14, 2019

To,

1. Managing Director, AEGCL, Bijuli Bhawan, Guwahati – 781 001
2. Managing Director, APDCL, Bijuli Bhawan, Guwahati – 781 001
3. Managing Director, APGCL, Bijuli Bhawan, Guwahati – 781 001
4. Director (Generation), Me. PGCL, Lumjingshai, Short Round Road, Shillong – 793 001
5. Director (Distribution), Me. ECL, Lumjingshai, Short Round Road, Shillong – 793 001
6. Director(Transmission), Me. PTCL, Lumjingshai, Short Round Road, Shillong – 793 001
7. Managing Director, MSPDCL, Secure Office Bldg. Complex, South Block, Imphal – 795 001
8. Managing Director, MSPCL, Electricity Complex, Keishampat, Imphal – 795 001
9. Director (Tech.), TSECL, Banamalipur, Agartala -799 001.
10. Director (Generation), TPGCL, Banamalipur, Agartala -799 001.
11. Chief Engineer (WE Zone), Department of Power, Govt. of Arunachal Pradesh, Itanagar- 791111
12. Chief Engineer (EE Zone), Department of Power, Govt. of Arunachal Pradesh, Itanagar- 791111
13. Chief Engineer (TP&MZ), Department of Power, Govt. of Arunachal Pradesh, Itanagar- 791111
14. Engineer-in-Chief (P&E), Department of Power, Govt. of Mizoram, Aizawl – 796 001
15. Chief Engineer (P), Department of Power, Govt. of Nagaland, Kohima – 797 001
16. CGM, (LDC), SLDC Complex, AEGCL, Kahilipara, Guwahati-781 019
17. Group General Manager, NTPC, Bongaigoan Thermal Power Project, P.O. Salakati, Kokrajhar- 783369
18. ED, NERTS, PGCIL, Dongtiah-Lower Nongrah, Lapalang, Shillong -793 006
19. ED (O&M), NEEPCO Ltd., Brookland Compound, Lower New Colony, Shillong-793003
20. ED (Commercial), NEEPCO Ltd., Brookland Compound, Lower New Colony, Shillong-793003
21. ED (O&M), NHPC, NHPC Office Complex, Sector-33, Faridabad, Haryana-121003
22. Vice President (Plant), OTPC, Badarghat Complex, Agartala, Tripura - 799014
23. GM, NERLDC, Dongtiah, Lower Nongrah, Lapalang, Shillong -793 006
24. Member Secretary, ERPC, 14 Golf Club Road, Tollygunge, Kolkata-700033
25. Chief Engineer, GM Division, Central Electricity Authority, New Delhi – 110066
26. Chief Engineer (NPC), NRPC Complex, Katwaria Sarai, SJSS Marg., New Delhi - 110016

**Sub: Minutes of 157<sup>th</sup> OCC Meeting.**

Sir/Madam,

Please find enclosed herewith the minutes of 157<sup>th</sup> OCC Meeting held at Guwahati on the **04<sup>th</sup> June, 2019** for your kind information and necessary action. The minute is also available on the website of NERPC, [www.nerpc.nic.in](http://www.nerpc.nic.in).

Any comments/observations may kindly be communicated to NERPC Secretariat at the earliest.

**Encl: As above**

भवदीय / Yours faithfully,

बि. लिंगखोइ / B. Lyngkhoi

निदेशक / Director/ SE

Copy to:

1. CGM, AEGCL, Bijuli Bhavan, Guwahati - 781001
2. CGM, APGCL, Bijuli Bhavan, Guwahati - 781001
3. CGM, DISCOM, Bijuli Bhavan, Guwahati - 781001
4. Head of SLDC, Me.ECL, Lumjingshai, Short Round Road, Umjarain, Shillong – 793 022
5. Head of SLDC, Department of Power, Govt. of Arunachal Pradesh, Itanagar- 791 111
6. Head of SLDC, Department of Power, Dimapur, Nagaland
7. Head of SLDC, Electricity Department, Govt. of Manipur, Keishampat, Imphal – 795 001
8. Head of SLDC, Department of Power, Govt. of Mizoram, Aizawl – 796 001
9. Head of SLDC, TSECL, Agartala – 799 001
10. Chief Engineer(Elect), Loktak HEP, Vidyut Vihar, Kom Keirap, Manipur- 795124
11. Addl. GM (EED), NTPC Ltd., Bongaigoan Thermal Power Project, P.O. Salakati, Kokrajhar- 783369
12. DGM (C&M), OTPC, 6th Floor, A-Wing, IFCI Tower -61, Nehru Place, New Delhi – 110019.



निदेशक / Director/ SE

North Eastern Regional Power Committee

**MINUTES OF THE 157<sup>th</sup> OPERATION COORDINATION**

**SUB-COMMITTEE MEETING OF NERPC**

**Date** : 04/06/2019 (Tuesday)  
**Time** : 15:00 hrs  
**Venue** : "Hotel Nandan", Guwahati.

The List of Participants in the 157<sup>th</sup> OCC Meeting is attached at **Annexure – I**

Shri P.K. Mishra, Member Secretary, NERPC welcomed all the participants to the 157<sup>th</sup> OCC meeting. He apprised the members about the achievements of the OCC forum in the past 4 years. In addition to the operational issues, he highlighted the successful completion of CDAC project and other ongoing projects like PDMS & ADMS. He hoped that the schemes would be highly beneficial to all the utilities of NER.

Thereafter, Member Secretary requested Shri B. Lyngkhoi, Director (O&P) to take up the agenda for discussion.

**A. CONFIRMATION OF MINUTES**

**CONFIRMATION OF MINUTES OF 156<sup>th</sup> MEETING OF OPERATION SUB-COMMITTEE OF NERPC.**

The minutes of 156<sup>th</sup> meeting of Operation Sub-committee held on 15<sup>th</sup> May, 2019 at Guwahati were circulated vide letter No. NERPC/SE (O)/OCC/2016/4556-4591 dated 22<sup>nd</sup> May, 2019.

*The Sub-committee may confirm the minutes of 156<sup>th</sup> OCCM of NERPC as no comments/observations were received from the constituents.*

**ITEMS FOR DISCUSSION**

**B.1. ACTION TAKEN:**

**1. IMPLEMENTATION OF PROJECTS FUNDED FROM PSDF:**

The status as informed in 157<sup>th</sup> OCC:

State	R&U scheme	ADMS	Capacitor Installation	SAMAST **	Line Differential Protection
-------	------------	------	------------------------	-----------	------------------------------

Ar. Pradesh	Pkg#I award by June'19 for diagnostic tools Pkg# II&III award in July'19	Tender published. LOA by May'19.	-	Not approved by TESG.	-
Nagaland	Could not be updated due to absence of DoP Nagaland representative		-	Not approved by TESG.	Lines identified. Under DPR preparation stage.
Mizoram	Could not be updated due to absence of P&ED Mizoram representative		To reply to TESG queries.	Not approved by TESG.	Lines not yet identified. To be taken up in Sub-group.
Manipur	LOAs issued. Completion by Jun'19.		To reply to TESG queries.	Not approved by TESG.	Lines not yet identified. To be taken up in Sub-group.
Tripura	90% completed. Remaining by May'19		Study to be carried out in consultation with NERLDC.	Not approved by TESG.	Lines not yet identified. To be taken up in Sub-group.
Assam	LOAs issued. Completion by Jun'19.		-	Appraisal Committee approved.	Lines identified. Under DPR preparation stage.
Meghalaya	MePTCL LOAs Completed Related Works target for completion by Jun'19. MePGCL - Erection complete by Mar'19		-	Appraisal Committee approved.	DPR already submitted and awaited approval.

ADMS tender was floated on 19.04.2019. Technical bid was opened on 22.05.2019 & Demo was carried out at SLDC Meghalaya on 24.05.2019. The price bid was opened on 29.05.2019 and accordingly the highest QCBS scoring bidder was deemed to be eligible for award.

The total contract price for the entire scope of work shall be Rs. 8, 34, 56,000.00 Crores (Rupees Eight Crores thirty four lakhs fifty six thousand only) exclusive of GST@18%. However, GST@18% or as per actual, shall be payable extra.

The state-wise contract price is given below:

Name of State	Contract Price (in INR) exclusive of GST
Arunachal Pradesh	1,03,00,925
Assam	1,70,24,284
Manipur	1,17,56,625
Meghalaya	1,08,80,738
Mizoram	1,03,00,925
Nagaland	1,11,02,794
Tripura	1,20,89,709
<b>TOTAL</b>	<b>8,34,56,000</b>

**Deliberation of the sub-Committee:**

**ADMS**

Director, NERPC highlighted the NIT details, demo etc. Further, he informed that upon Price Bid Evaluation it was found that M/s Orbit Techsol India Pvt. Ltd. has scored the highest marks as per QCBS. He highlighted the methodology of prorated pricing as indicated above and asked the opinions from the States. All the state utilities agreed to the pro-rata division of the Contract price and approved awarding of work to M/s Orbit Techsol India Pvt. Ltd. Member Secretary, NERPC handed over the LOA to M/s Orbit Techsol India Pvt. Ltd. The forum decided that SE, SLDC, Meghalaya would be the nodal officer and would guide the other states regarding the TPA, A/C creation details etc.

M/s Orbit Techsol India Pvt. Ltd. informed that for ADMS Project Manager would be Mr. Rajesh Bhargava. Further, the following points were highlighted as part of kick start of the project:-

- The implementation would be done state by state.
- Site survey SLDC & Substations - Substations would be identified and presence of requisite infrastructure to be ascertained. GPRS network availability also to be ascertained.

Expected supporting actions amongst others:

- OPC access shall be provided from the concerned servers in redundant configuration
- Enable OPC Server tool in CFE
- Configure processor starter and Add OPC App process

- Add OPC Server in Data Source and Data sets in existing database

The detailed presentation is attached at **Annexure-B.1-I**.

The forum decided that Arunachal Pradesh would be the pilot state for implementation.

### **SAMAST**

Director, NERPC informed that the breakup of the approved cost i.r.o. Assam and Meghalaya would be circulated. Further, he requested for the decision of the forum reg. Scope of NIT for SAMAST

NERLDC informed that NLDC is in the process of giving a reply to TESG. In respect of Tripura the data collected from Tripura is attached (as **Annex.B.1**). It was pointed out that in case of Tripura unbundled entities are present as well as generating plants.

In case of Manipur it was highlighted that as per MoM of JERC, Intra-state meters' procurement has been discontinued because of SAMAST. So SAMAST is urgently required. Director, NERPC informed that one of the stipulations of TESG was the presence of more than one DISCOM in the state. But in case of Assam & Meghalaya, even though one DISCOM is present, the scheme has been approved.

Further, it has been informed by TESG that direction from CERC is required rather than recording of FOR.

CGM, NERLDC opined that the scheme will be unnecessarily delayed if NERPC waits for approval i.r.o the other states. He suggested that the scheme be implemented in two phases:

Phase-I : Assam & Meghalaya

Phase-II: Other states.

Member Secretary, NERPC opined that PSDF funds are limited and utilization is of the utmost importance. The forum decided that i.r.o Assam & Meghalaya NIT to be called immediately with the scope of work limited to two states which would be extended to the other 5 states later on upon approval. The members unanimously agreed that reduction of fund not deemed justifiable, since work would not be completed. So Item by item breakup will be checked by SAMAST group for practical feasibility in implementation. A reply would be sent in this regard by 12.06.2019.

***The Sub-Committee noted as above.***

***Action: All state utilities/NERPC.***

**B.2. OPERATIONAL PERFORMANCE AND GRID DISCIPLINE DURING MAY, 2019**

As per the data made available by NERLDC, the grid performance parameters for May, 2019 are given below:

**NER PERFORMANCE DURING MAY, 2019**

States	Energy Met (MU)		w.r.t. Apr, 19 % inc (+) /dec (-)	Energy Reqr. (MU)		w.r.t. Apr, 19 % inc (+) /dec (-)	% inc (+) /dec (-) of energy reqr vs met. In May, 19
	May-19	Apr-19		May-19	Apr-19		
Ar. Pradesh	63.86	66.12	-3.42	64.24	66.47	-3.35	-0.59
Assam	738.39	708.86	4.17	819.22	766.33	6.90	-9.87
Manipur	72.19	66.84	8.00	72.70	67.86	7.13	-0.70
Meghalaya	159.02	159.74	-0.45	167.32	169.77	-1.44	-4.96
Mizoram	54.80	53.14	3.12	55.16	53.58	2.95	-0.65
Nagaland	64.40	53.71	19.90	64.94	54.16	19.90	-0.83
Tripura	170.42	120.04	41.97	172.78	121.50	42.21	-1.37
<b>Region</b>	<b>1323.08</b>	<b>1228.44</b>	<b>7.70</b>	<b>1416.36</b>	<b>1299.66</b>	<b>8.98</b>	<b>-6.59</b>

States	Demand Met (MW)		w.r.t. Apr, 19 % inc (+) /dec (-)	Demand in (MW)		w.r.t. Apr, 19 % inc (+) /dec (-)	% inc (+) /dec (-) of energy reqr vs met. In May, 19
	May-19	Apr-19		May-19	Apr-19		
Ar. Pradesh	138	136	1.47	140	139	0.72	-1.43
Assam	1673	1667	0.36	1753	1712	2.39	-4.56
Manipur	181	188	-3.72	183	197	-7.11	-1.09
Meghalaya	325	337	-3.56	329	336	-2.08	-1.22
Mizoram	100	113	-11.50	102	116	-12.07	-1.96
Nagaland	128	131	-2.29	130	157	-17.20	-1.54
Tripura	295	291	1.37	297	292	1.71	-0.67
<b>Region</b>	<b>2674</b>	<b>2780</b>	<b>-3.81</b>	<b>2758</b>	<b>2848</b>	<b>-3.16</b>	<b>-3.05</b>

**REGIONAL GENERATION & INTER-REGIONAL EXCHANGE IN MU**

Month---->	May-19	Apr-19
Total Generation in NER (Gross)	1822.984	1292.409
Total Central Sector Generation (Gross)	1464.987	1022.260
Total State Sector Generation (Gross)	357.997	270.149
<b>Inter-Regional Energy Exchange</b>		
(a) NER-ER	<b>257.68</b>	<b>369.78</b>
(b) ER-NER	<b>103.77</b>	<b>12.19</b>
(c) NER-NR	<b>174.76</b>	<b>0.00</b>
(d) NR-NER	<b>0.00</b>	<b>433.00</b>
© Net Import	-328.67	75.41

**AVERAGE FREQUENCY (Hz)**

Month---->	May-19	Apr-19
	% of Time	% of Time
Below 49.9 Hz	8.43	7.48
Between 49.9 to 50.05 Hz	74.15	74.66
Above 50.05 Hz	19.55	19.99
Average	50.00	50.00
Maximum	50.33	50.29
Minimum	49.65	49.65

**Deliberation of the sub-Committee:**

NERLDC gave a presentation on the grid performance for the month of May'19 (**Annexure-B.2**). NERLDC also highlighted that Daily, Weekly and Monthly Voltage Deviation Report, Frequency Deviation Report and System Reliability Report for May'19 was already mailed to all the constituents for necessary actions. Further, it was informed that members may access these reports from NERLDC website under the tab CERC KPI Reports. NERLDC informed the forum about the number of lines kept open on high voltage. NERLDC again requested for early restoration of reactors which are under long outage and commissioning of new reactors at the earliest as mentioned in Sl. No. B.1.2 and C.1 and support from Generator to control voltage so that it does not require to open lines for maintaining voltage profile within IEGC band.

NERLDC informed the following:

Zero Crossing Violations

Maximum violation by Arunachal Pradesh at 323 nos.

Minimum violation by Tripura at 23 nos.

Total number of Grid Disturbances -20 and total number of Grid Incidences-19

Shutdown

OCC approved - 153 nos

Emergency shutdown - 28 nos

Non-OCC approved - 4 nos

Total number of shutdowns Aailed – 86 nos

NERLDC also highlighted the salient points of the DSM fifth amendment regulations:

- W.e.f. 03.06.19 upto 31.03.2020 sign has to change after every twelve time blocks.
- No ZCV would be there if drawal within +/- 20MW from their schedule.
- Everyday from 00:00hrs the counter would be reset.
- Each ZCV violation would attract an additional charge of 10% of the time block (13th time block in this case) DSM charge payable or receivable as the case may be.
- Additional charges based on the total number of violations in a day.

***The Sub-Committee noted as above.***

**C. ITEMS - STATUS REVIEW**

**C.1. Update on Real Time Energy Assessment for Effective Grid Management:**

In 155<sup>th</sup> OCC meeting, the following were decided:

- CDAC to complete installation of TARA devices for replaced SEMs by 30.04.2019.
- Integration of WBES schedule & SMS alert app to be deployed by CDAC by April'19

The 156<sup>th</sup> OCC forum requested NERLDC & NERPC to co-ordinate for the SAT of CDAC project by 1<sup>st</sup> week of June'19.

**Deliberation of the sub-Committee:**

Director, NERPC informed installation & commissioning certificate for Server and associated systems in NERLDC has been given and final 10% would be disbursed soon.

***The Sub-Committee noted as above.***

***Action: NERPC***

**C.2. Ensuring proper functioning of Under Frequency Relays(UFR) & df/dt Relays:**

In 7<sup>th</sup> NPC meeting held on 08.09.17 it was agreed that mock test is good enough to test the healthiness of the UFR & df/dt relays. The frequency of site inspection was proposed to be upto six months. RPC may carry out periodic inspection, in line with provisions of IEGC and furnish inspection reports to NPC.

Deliberations in the previous meetings:-

- Inspection for Mawphlang completed.
- Inspection for Sankardevnagar, Rangia and Rowta under Assam was completed in April'2019.
- UFR Inspection in Tripura - TSECL to inform the suitable date(s) for inspection.

Tripura – 11.06 to 15.06 all UFR stations as well as stations under Islanding scheme

**Deliberation of the sub-Committee:**

After detailed deliberation, it was agreed that the UFR Inspection and Testing for TSECL Stations as well as UFRs under Islanding Scheme No.2, would be carried out for TSECL Stations from 24.06.19 to 28.06.19.

***The Sub-Committee noted as above.***

***Action: TSECL, NERLDC, NERPC.***

**C.3. Extended C Band VSAT for power system communications in NER:**

The 155<sup>th</sup> OCCM decided that since the project was a pilot one, the order may be given to M/s KPTCL. Accordingly, CGM-NERLDC was requested to convey the same to M/S KPTCL

In 156<sup>th</sup> OCCM CGM, NERLDC informed that KPTCL has committed to go ahead with the Pilot Project. The readiness for immediate execution of the same will be communicated.

MePTCL raised apprehensions regarding the possibility of Cyber Security breach at Killing as a fallout of this pilot. NERLDC informed that the same has already been taken care of, which will be addressed by GM(SL), NERLDC.

**Deliberation of the sub-Committee:**

CGM, NERLDC informed that the queries have already been addressed by NERLDC. He also informed that Cyber Security aspects are taken care by the firewall. MePTCL requested that the same may be intimated to EE, Killing.

***The Sub-Committee noted as above.***

***Action: NERLDC***

**C.4 Phase shift errors in PMU:**

In 155<sup>th</sup> OCCM Director, NERPC informed that in the Sub-group meeting held on 05.04.19, it was agreed that the matrix of phase comparison for each of the stations vs Bongaigaon will be prepared by NERLDC. NERLDC informed that work is underway and would be completed by April'19.

In 156<sup>th</sup> OCCM, NERLDC informed that the matrix has been prepared, with deviations being categorized in three groups: (i) +120 deviation, (ii) -120 deviation, (iii) matching w.r.t Bongaigaon.

Sr.GM(AM), NERTS informed that for some ASEB stations 90 deg deviation is present which has to be checked

Within one week the data w.r.t. connection changes will be collected by NERTS in conjunction with AEGCL and rectification would be completed by May'19 for substations with +/- 120 degree and planning of activities to correct the phase shift of -90 or +150 degree group shall be made by May 2019.

**Deliberation of the sub-Committee:**

Sr.GM(AM), NERTS assured that the complete schedule of works would be prepared by 14<sup>th</sup> June,2019. The forum requested AEGCL to do likewise.

***The Sub-Committee noted as above.***

***Action: AEGCL/NERTS***

**C. 5 Tentative schedule for Black Start & Restoration Procedure Mock exercise in NER during the year 2019**

In 156<sup>th</sup> OCCM the mock black start schedule was agreed as below:

AGTCCPP completed

LOKTAK 20.05.19 to 23.05.19

Khandong completed on 09/05/2019

KOPILI completed on 10/05/2019

RHEP to be done in lean season

DOYANG 12<sup>th</sup> June'19

**Deliberation of the sub-Committee:**

NHPC informed that for seamless and interruption free black start testing, commissioning of 132kV Bus-A is required. The forum decided that post commissioning of the same, Black Start testing would be done.

Regarding Doyang HEP, NEEPCO informed that the exact date would be confirmed by 12.06.2019.

Mock Black Start operation for Doyang is scheduled on 12th June. CGM, NERLDC stated that for AGBPP black start, 800KVA DG set is available while 500KVA is required for self start. Further Double Main Bus is also available.

Sr. Manager, NEEPCO informed that being a thermal plant black start facility is not available at AGBPP. CGM,NERLDC opined that whenever any of the unit synchronised after outage at AGBPP, efforts will be made for synchronisation by availing auxiliary power supply through DG set. On successful synchronisation, Black-start procedure will be updated suitably. NEEPCO agreed to revert back on the matter.

***The Sub-Committee noted as above.***

***Action: NEEPCO, NHPC, NERLDC***

**C. 6 Reactive power capability/injection of generating stations:**

As per discussion in previous meeting(s) the following needs to be updated:

- PG Test Reports of Pare - NERLDC to confirm sufficiency.
- Procedure for reactive capability testing to be discussed and finalised.
- Study report regarding MVAR control with tap changing of ICT at Palatana to be discussed.

**Deliberation of the sub-Committee:**

NERLDC informed that till 31.05.2019 no comments have been received on the reactive capability testing. OTPC informed that reply from BHEL is awaited and OTPC comments would be intimated by next OCC or at the earliest upon receipt of communication from BHEL.

NERLDC informed that as per NERLDC half yearly tap optimization study the tap changing at Palatana ICT is not required and suggested that the item be dropped.

***The Sub-Committee noted as above.***

***Action: NEEPCO/OTPC/NERLDC***

**C.7 Review of relay settings at Karong:**

In 156<sup>th</sup> OCCM it was brought to notice that the flow in the 132kV karong-Kohima is being limited (at 20MW from Karong to Kohima) via relay settings at Karong. The forum noted that this would lead to unwanted trippings of the line and requested MSPCL to review the same.

**Deliberation of the sub-Committee:**

DM, MSPCL informed that due to constraint in 132kV Imphal – Imphal Ckt#II, the flow in 132kV Karong-Kohima was restricted with relay settings. After commissioning of 132kV Imphal-Imphal Ckt#III this would be reviewed.

The forum advised that relay should not be used as load limiter. After detailed deliberation it was agreed that by by June'19 the relay settings would be revised.

On a specific query by NERLDC on CT ratio of 132 kV Karong – Kohima line, MSPCL informed that this will be intimated after consultation with officials of 132 kV Karong by Jun'19.

***The Sub-Committee noted as above.***

***Action: MSPCL***

**C.8 Restoration of SCADA for control and annunciation:**

The SCADA for control and annunciation of 132 kV Kopili Khandong Feeder II and 220/132 kV, 160 MVA ICT is not in operation since a long period of time leading to difficulty in monitoring and operation. POWERGRID may be requested to restore the same or separate control and monitoring panel for the feeder at the earliest.

In 156<sup>th</sup> OCCM NERTS assured that SCADA, C&R panel will be restored ASAP possibly by May'19

**Deliberation of the sub-Committee:**

Sr.GM(AM), NERTS informed that due to miscommunication the target was wrongly given as May'19. He stated that temporary arrangement for Annunciation would be done by June'19 while the full-scale SCADA integration is linked to GIS. target for full-scale SCADA integration would be informed later on.

**The Sub-Committee noted as above.**

**Action: NERTS**

**C.9 Shutdown related to upgradation of 132kV Motonga Sub-station in Bhutan:**

Deliberations in the 156 <sup>th</sup> OCCM	Status as on 31.05.19	Status as informed in the 157 <sup>th</sup> OCCM
<p>1) <u>Date for ERS shifting - nature and duration of shutdown.</u>                      For erecting on ERS 2-3 days continuous shutdown of 132kV Rangia-Motonga is required. The date(s) may be intimated so that shutdown can be approved accordingly.</p>	<p>01.06.2019 to 03.06.2019</p>	<p>Completed</p>
<p>2) <u>Protection settings at Rangia</u>                      Line parameters are already available with NERTS/POWERGRID for the 132kV Rangia-Deothang. The parameters for the line from Tee point to Silicon factory has to be provided by Bhutan. During shutdown NERTS would visit and revise the settings.</p>	<p>For protection setting and line parameters from Tee point to Silicon factory, Divisional Manager, Deothang has been requested to provide necessary data</p>	<p>NERTS to visit Rangia on 05.06.19.                       DR standardization &amp; settings to be revised.</p>

<p>3) <u>Metering &amp; Accounting issues</u> NERLDC stated that presently meter reading at Rangia end is used for Accounting purpose and SEM at Motonga is used for verification. In the revised configuration similar arrangement would be followed with Rangia end is used for Accounting purpose and SEM at Deothang/SILICON factory used for verification.</p> <p>However, the meters at Deothang end &amp; Silicon factory end are ABT compliant or not, is to be confirmed. NERLDC also requested the forum regarding sample meter readings of Deothang and Silicon Factory meters for verification purpose. It was decided that NERTS would visit Deothang/Silicon factory and verify the same including collection of IR during the time of shutdown.</p>	<p>Meters at Deothang (presently installed at Motonga end) and Silicon factory(to be installed) are ABT compliant.</p> <p>Installation of ABT meters at Deothang and Silicon factory end to be done during shutdown period. NERTS to coordinate.</p> <p><b>Following meter readings are to be taken jointly by NERTS and Bhutan:</b></p> <p>(i)Final Reading of SEM at Motonga prior to dismantling</p> <p>(ii)Final reading of Main Energy Meters at Deothang and Silicon Factory prior to dismantling</p> <p>(iii)Initial SEM reading at Deothang and Silicon Factory</p> <p>Bhutan has clarified that SEMs at Deothang &amp; Silicon Factory are to be used for Accounting since presently Motonga is being used.</p>	<p>Meters installed. IR&amp;FR recorded</p> <p>NERLDC informed that the sample readings of both the meters at Deothang and Silicon Factory were received by NERLDC and the readings were found compatible.</p>
--	--	--

**The Sub-Committee noted as above.**

**Action: NERTS**

**C. 10 Status of recommendations reg GD-Vs on 03<sup>rd</sup> & 20<sup>th</sup> April,2019:**

<b>Recommendations</b>	<b>Status as informed in the 157th OCCM</b>
Review of negative phase sequence relay settings for GBC motor at Monarchak (Scope of NEEPCO)	Settings send to BHEL. No reply yet Expected by June'19
Identification of weak joints for 400kV Palatana-Silchar D/C ( Scope NERTS)	Sample of failed conductor to be sent to the manufacturer by NETC for RCA as the conductor suffered mechanical breakage. There was no issue with joints.

Loading limit of 132kV PKBari-Dhalabil to be informed (Scope of TSECL)	60MW
Hotline communication from Silchar to Palatana (Scope of NERTS/OTPC)	Available. Pickup at Silchar no response due to unmanned station at Silchar. Extension to a particular location by NERTS where manpower is available.
Study for reactive compensation in Tripura System(scope of TSECL)	NERLDC informed that node wise MVAR data of 33 kV system is required to carry out the studies. TSECL informed that MVAR data at 33 kV level is not available at SLDC. Forum requested TSECL to monitor & record MVAR data at 33 kV nodes for 1 month and submit the data for study.
Identification of feeders for additional UFR based load shedding under Islanding Scheme-II( Scope of TSECL)	During inspection it is to be done
Review of 132kV Imphal - Imphal D/C overvoltage settings at Imphal(MAN) ( Scope of MSPCL)	Permission of MD,MSPCL is awaited
NERTS to visit AGTCCPP and check relay/DR downloading facility in one week	Completed. NERTS to explain the procedure to NEEPCO
Standalone EL for integration of relay at AGTCCPP by Oct'19(Scope of NEEPCO)	AGTCCPP - Oct'19. Standalone EL at RHEP completed in June'19
All stations to confirm DR downloading facility and it's healthiness at respective stations. A consolidated undertaking by the respective utility in this regard is to be submitted prior to each OCCM.	To be made into permanent agenda item wherein compliance from all utilities to be recorded. It was decided that all utilities to submit the declaration by 2nd of the month to NERPC & NERLDC.
NHPC to procure standalone EL for Loktak HEP	Dec'2020 because no budget provisions
NERTS would explore options in consultation with OEM regarding time synchronization issues at Silchar	Undergoing. Referred the case to OEM
Upon SPS-2 activation 132kV Bus Coupler Breaker to be opened at Palatana. Old scheme of opening of HV side CBs of ICTs to be disabled/removed (Scope of OTPC)	Not implemented. OTPC informed that By Opening of Bus Coupler would will lead to blackout of Palatana. To be discussed during visit of UFR Inspection team to Palatana.
Revised SPS-3 scheme offer sought from GE by NERTS	Technical offer Received from GE. Attached at <b>Annex.C.10</b> . Once technical clearance is given to GE, they will submit the commercial offer.
Line defects in 400kV Silchar - Azara & 400kV Silchar-Byrnihat T/L to be attended(Scope of NETC)	To be executed in the next shutdown
Impedance measurement for 400kV Paltana-Silchar D/C, 400kV Silchar-Azara, 400kV Silchar - Byrnihat	On opportunity

Line parameters to be matched at Silchar, Azara and Byrnihat.	To be informed
Spare relay REL 670 to be installed at Byrnihat for 400kV Silchar-Byrnihat(Scope of MePTCL)	S/d postponed. By June'19
NERTS and AEGCL to jointly visit Azara and check exact cause for delay in appearance of voltage input to relay when charged via Tie Breaker	To be informed

**Deliberation of the sub-Committee:**

CGM, NERLDC opined that any recommendations of Sub-group may be examined by higher or other forum. In case of non-compliance or absence of timeframe for implementation petition to CERC may be allowed.

***The Sub-Committee noted as above.***

***Action: NETC, NERTS, MePTCL, AEGCL, OTPC, NEEPCO, TSECL.***

**C.11 Installation of Anemometer:**

As per CERC Order in Petition number 9/SM/2014 dated 14.06.16, Hon'ble CERC has directed PGCIL to install Anemometer in all its sub-stations to record wind speed. In 132nd OCCM, DGM (AM), NERTS informed that installation of anemometers is being carried out in SR-1. After satisfactory performance, anemometers will be installed in other regions. In 142nd OCCM, NERTS was requested to present Action Taken Report for installation of anemometers.

**Deliberation of the sub-Committee:**

CGM, NERLDC informed that IMD would install 150 nos AWS in NER. IMD proposed to set up AWS in substations of NER which will require around 10x10 space and they are ready to share data with NERLDC & SLDCs which will be beneficial for load forecast.

The forum agreed in-principle and requested IMD to give presentation in the next OCCM.

***The Sub-Committee noted as above.***

***Action: NERLDC***

**C. 12 Metering Status Review:**

Agenda Description	Latest Status	Status as informed in 157th OCCM
Distribution of 70 Laptops	Laptops would be distributed by 15th May'19.	NERLDC has forwarded the distribution list of Laptop to NERTS.

		<p>NERTS is requested to coordinate with constituents for laptop distribution. Distribution list attached at <b>Annexure-C.12</b></p>
<p>Correction of Meter error at Pare, Ningthoukhong, Kohima, Jiribam(man), Dimapur(s).</p>	<p>YET TO BE CORRECTED.</p>	<p><b>The following errors are still persisting -</b>  <b>1) Sign reversal problem at following locations -</b>                  a) Lekhi end of 132 kV Pare-Lekhi line.                  b) Kohima end of 132 kV Dimapur-Kohima line.  <b>Low meter reading Problem at following locations -</b>                  a) Ningthoukhong end of 132 kV Imphal-Ningthoukhong line.                  b) Jiribam(S) end of 132 kV Jiribam(PG)-Jiribam(S) line.                  c) Dimapur(S) end of both 132 kV Dimapur(PG)-Dimapur(S) ckt I &amp; II lines.                  NERLDC requested the concerned to take rectification works at the earliest.</p>

*The Sub-Committee noted as above.*

*Action: NERLDC/NERTS/All other utilities*

<b>D. ITEMS FOR DISCUSSION</b>
--------------------------------

**D.1 Generation Planning (ongoing and planned outages)**

- a. Present per day MU and projected number of days of operation.

Plants	Reservoirs level in meter	MU content	Present DC (in MU)	No of days as per current generation
Khandong + Kopili stg II	714.95	73.022	1.398	52
Kopili	602.4	368.8645	4.46	83
Doyang	306.609	7	0.135	52
Loktak	766.64	16	1.05	15

The outage of other generating stations may be approved considering the present water levels in reservoirs.

*The Sub-Committee discussed and approved the proposed shutdown by Generating Stations as given in Annexure - D.2 which is available in NERPC website.*

**D.2 Outage Planning Transmission elements**

It was agreed in the 99<sup>th</sup> OCC meeting that shutdown will be availed only after approval is given by the OCC forum. It was also agreed that deferment/revision of outages elements other than already approved in OCC will be henceforth put/displayed in the website of NERPC (**under Operational Activities/OCC Approved shutdown**) as per CERC regulations/ CEA guidelines etc for ensuring smooth & secure grid operation.

**Furnishing request of shut down of the element, which was approved by NERPC, by Indenting Agency (ISTS licensees/STUs/Generating Companies) to NERLDC:** Planned shutdown approved by NERPC shall be considered for implementation by NERLDC on D-3 basis. If an outage is to be availed on say 10<sup>th</sup> of the month, the shutdown availing agency would reconfirm to NERLDC on 7<sup>th</sup> of the month by 10:00 Hr. This practice is necessary to ensure optimal capacity utilization and the time required for associated system study/coordination by/amongst RLDC/NLDC.

In the Special Meeting held at Palatana, OTPC on 02.05.19 it was decided that no shutdown would be granted to utilities not submitting DR/EL regularly.

For shutdown of 400kV Palatana-Silchar Ckt#I or Ckt#II OTPC agreed to back down generation by 300MW subject to good weather conditions and sharing of study results.

*The sub-Committee discussed and approved the transmission line outages proposed by Constituents for June,2019-July,2019 which is available in the website of NERPC.*

**D.3 Estimated Transmission Availability Certificate (TAC) for the month of March, 2019 - April,2019:**

NETC and POWERGRID have submitted the outage data for the month of March, 2019 - April,2019. So the attributability of outage of the said elements may please be finalized.

**Deliberation of the sub-Committee:**

NERLDC informed that as per new Regulations the outage data has to be given to the DICs also. This is to be submitted to NERLDC & all the state beneficiaries by 5th of every month. NERLDC also informed that comments on monthly outage data will be published in the NERLDC website for reference of constituents.

*The Sub-Committee noted as above.*

**Action: NERTS/NETC.**

**D.4 Assessment of TTC, TRM & ATC by SLDC on respective Inter-State Transmission Corridor**

The forum requested all the SLDCs to carry out the TTC/ATC calculations and decided that SLDC Ar. Pradesh would give presentation in the next OCC.

**Deliberation of the sub-Committee:**

It was decided that SLDC Ar. Pradesh would give presentation in the next OCC.

*The Sub-Committee noted as above.*

**Action: DoP Ar.Pradesh**

**D.5 Methodology for taking generating stations under RSD:**

Methodology for taking generating station under RSD in case of low requisition resulting in despatch schedule less than technical minimum. The methodology is enclosed as **Annexure D.5**.

**Deliberation of the sub-Committee:**

NERLDC elaborated the detailed procedure (attached at **Annexure-D.5**). The salient points are as follows:

- If RSD is accorded then for 8hrs machine would be under RSD.
- To avoid going under RSD or bringing back from RSD, states have to increase their requisition, no jack up by NERLDC.

- In real time if schedule is less than technical minimum, then generators may take decision whether to take the unit under RSD or not.
- Methodology of revival of the generators: 8hrs for coal based station, after revival then at least 8hrs schedule greater than Technical Minimum to be given.

Members agreed to revert back with their comments by 20<sup>th</sup> June,2019. NERLDC will issue the final procedure after incorporating the applicable feedback / suggestion and the revised procedure will be implemented with effect from 1st July'19.

***The Sub-Committee noted as above.***

***Action: All utilities***

#### **D.6 Patrolling protocols/guidelines:**

Finalization of patrolling protocols/guidelines for NER as per CERC order No 146/MP/2013 with I.A. 36/2013.

#### **Deliberation of the sub-Committee:**

After detailed deliberation members were requested to submit their comments by June'19.

***The Sub-Committee noted as above.***

***Action: All utilities***

#### **D.7 Training program on Power System Studies:**

HRD Training Program on Power System Studies will be conducted tentatively during second week of July'19 at NERLDC. All SLDCs are requested to participate the program.

#### **Deliberation of the sub-Committee:**

CGM, NERLDC informed that the training program would be conducted on 15th & 16th July,2019. He requested all the SLDCs to send their nominations at the earliest.

***The Sub-Committee noted as above.***

***Action: All SLDCs***

#### **D.8 Better weather forecasting for power sector by IMD:**

During the interaction of NERLDC with IMD, Guwahati, they requested to set up observatories in appropriate substations covering all important locations of NER states, which will be beneficial for power utilities of NER.

Also, NERLDC in coordination with IMD, Guwahati proposes to conduct one-hour knowledge sharing session on "Meteorological requirements of Power System Operation" in next OCC Meeting.

**Deliberation of the sub-Committee:**

Pls refer to discussion in item No. C.11.

***The Sub-Committee noted as above.***

**D.9 List of Important grid elements:**

Document on List of Important Grid Elements is to be published as per compliance with IEGC 5.2.c on 31st May'19. Utilities were requested to update the file as per discussions in 153rd, 155th & 156th OCC meetings. Data/comments received from utilities till 28th May'19 was considered for finalization.

**Deliberation of the sub-Committee:**

Document on List of Important Grid Elements was published as per compliance with IEGC 5.2.c on 31st May'19 and is available at NERLDC website at <http://nerldc.in/IE.aspx>.

***The Sub-Committee noted as above.***

**D.10 Draft Operating Procedures:**

**Deliberation of the sub-Committee:**

NERLDC informed that Draft Operating Procedure for the year 2019 has been mailed to all Utilities. Utilities are requested to give comments by 30th Jun'19.

***The Sub-Committee noted as above.***

***Action: All utilities***

**Metering Agenda**

**D.11 METER ERRORS:**

1. Pair check error observed in following location, CT / PT error suspected.

l) Kohima-Karong, Kohima end reading is less than 20%.

**Deliberation of the sub-Committee:**

Low meter reading problem at Kohima end of 132 kV Karong-Kohima line is still persisting. NERLDC requested the concerned to take necessary corrective action at the earliest.

***The Sub-Committee noted as above.***

***Action: DoP Nagaland***

**D.12 High SEM Time Drift:**

Time drift in SEMs may result in computational errors in Regional energy accounts & Weekly Loss. All constituents in whose premises the meters are installed are required to take corrective action for time correction whenever meter time drift > 1minute and submit weekly compliance report of the same to NERLDC.

The compliance report of many locations as detailed in **Annexure D.12(I)**, are not received by NERLDC and **Annexure D.12(II)** provides location details of Drift correction action not being done / weekly SEM data not sent.

**Deliberation of the sub-Committee:**

NERLDC requested all constituents to make necessary time drift corrections on a regular basis and also to provide time drift report regularly. NERLDC also pointed out the list of stations who were not sending the SEM readings. NERLDC requested the concerned to send weekly SEM data on a regular basis. The details are attached in **Annexure D-12(I) and Annexure-D-12(II)**.

***The Sub-Committee noted as above.***

***Action: All utilities***

**D.13 SEMs to be repaired:**

Considering precarious stock position of Spare SEMs, a list of 78 SEMs has been prepared as per Annexure C. These may be repaired at the earliest.

**Deliberation of the sub-Committee:**

NERLDC has provided the list of SEMs to be repaired to NERTS. The details of the same is attached in **Annexure D-13**.NERLDC requested NERTS to do the necessary repairing works at the earliest keeping in view of less no of spare meters in the region.

***The Sub-Committee noted as above.***

***Action: NERTS***

**D.14 Up-dation of DSM Statement Accounts and DSM Data file**

Consequent upon the implementation of DSM and related matters (Fourth Amendment) Regulations, 2018, ZVC surcharge has been imposed. Even though communication has been received from NERLDC/POSOCO weekly charges on ZVC, however NERPC has not updated Deviation Account Statement and DSM data file with effect from Week-43 (i.e 21.01.2019 to 27.01.2019). It is desired that the Deviation Account Statement under ABT regime be always accompanied by energy details –

Schedule, Actual, Deviation and ZVC details (for energy accounting purpose) be issued in timely manner.

In these circumstances, it is not possible to process for payments on account of ZVC surcharge. So updation of Deviation Account Statement and Data file for DSM is an urgent need with a view of possible late payment interests.

**Deliberation of the sub-Committee:**

Director, NERPC informed that in light of the 4th amendment regulations, some software issues were encountered. This has since been corrected and the accounts would be issues very soon.

***The Sub-Committee noted as above.***

***Action: NERPC.***

**D.15 Telemetry data from AGBPP**

As per info from NERLDC, RTU data from AGBPP not reporting to NERLDC. Service engineer was called by NEEPCO. The RTU was checked and the problem rectified. Further, it was confirmed that there is PLCC link failure between Kathalguri and Mariani. It is suspected that problem is in the ABB PLCC panel and same has to be rectified at Mariani. The Card is damaged, cooling fan motor not working. The forum requested NERTS to attend to the problem immediately. NERTS agreed to attend soon.

***The Sub-Committee noted as above.***

***Action: NERTS.***

**Date & Venue of next OCC meeting**

It is proposed to hold the 158<sup>th</sup> OCC meeting of NERPC on second week of July 2019. However, the exact date and venue will be intimated in due course.

The meeting ended with thanks to the Chair.

\*\*\*\*\*

**Annexure-I****List of Participants in the 157<sup>th</sup> OCC Meeting held on 04<sup>th</sup> June, 2019**

SN	Name & Designation	Organization	Contact No.
1.	Sh. N. Perme, SE (E), SO & PSC	Ar. Pradesh	9436288643
2.	Sh. Dipesh Ch. Das, AGM (LDC)	Assam	09954110254
3.	Sh. Ravendra Choudhury, GM APGCL	Assam	09435143426
4.	Sh. Bibhu Medhi, AGM, APDCL	Assam	-
5.	Sh. Indrajit Tahbildar, Dy. Manager, APDCL	Assam	-
6.	Sh. Bimal Ch. Das, AGM, SLDC	Assam	09435119248
7.	Sh. K. Goswami, Consultant (COM)	Assam	09864020019
8.	Sh. Adahrii Kayima, Dy. Manager	Manipur	08132823793
9.	Sh. W. Khyriem, EE, GSPD	Meghalaya	09856007107
10.	Sh. A.G.T ham, AEE, MePTCL	Meghalaya	09774664034
11.	Sh. T. Gidon, EE, SLDC	Meghalaya	09774479956
12.	Sh. Y. Iakai, AE, SLDC	Meghalaya	09402133552
13.	Sh. Benjamin L. Tlumtea, Sr.EE, SLDC	Mizoram	09436151424
14.	Sh. David Lalnumpuia, JE, SLDC	Mizoram	09436135889
15.	Sh. Rokobeito Iralu, SDO (Trans.)	Nagaland	09436832020
16.	Sh. Anil Debbarma, DGM, SLDC	Tripura	09612589250
17.	Sh. D. Baishya, DGM (E/M), AGBP	NEEPCO	09435339966
18.	Sh. Tanya Tazi, Manager	NEEPCO	09436662053
19.	Sh. Bhaskar Goswami, DGM (E/M), O&M	NEEPCO	09436163983
20.	Sh. V. Suresh, CGM	NERLDC	09449599156
21.	Sh. R. Sutradhar , DGM (SO-I)	NERLDC	09436302714
22.	Sh. Amaresh Mallick, Sr. GM (SO-II)	NERLDC	09436302720
23.	Sh. Jerin Jacob, Asst. Manager (SO-II)	NERLDC	09602120113
24.	Sh. Ankit Jain, Manager	NERLDC	09436335381
25.	Sh. Keshab Borah, Engineer	NERLDC	07002323608
26.	Sh. Debashish Mondal, Dy. Manager	NERLDC	08787834941
27.	Sh. Dinesh Rai, JE	NERLDC	09101593482
28.	Sh. P. Kanungo, Sr. GM (AM)	PGCIL	09436302823
29.	Sh. Sanjay Kumar Sharma, Manager (E)	NHPC	09800016796

30.	Sh. Narendra Kumar Gupta, Sr. Mgr. (O)	OTPC	09774233426
31.	Sh. Ramakanta Panda, GM (O)	NTPC	09650991355
32.	Sh. B. Choudhury, AGM (EEMG)	NTPC	09435503167
33.	Sh. R.K. Sarkar, Director (Projects)	NETC	09910378084
34.	Sh. B. Choudhury, AGM (EEMG)	NETC	09435503167
35.	Sh. Mohan Jha, Consultant	ERPC	09874738913
36.	Sh. P.K. Mishra, Member secretary	NERPC	09968380242
37.	Sh. B. Lyngkhoi, Director (O&P)	NERPC	09436163419
38.	Sh. S. Mukherjee, AD	NERPC	08794277306

**NERPC ADMS  
PROJECT:  
IMPLEMENTATION OF  
AUTOMATIC DEMAND  
MANAGEMENT  
SCHEME FOR NORTH  
EASTERN REGION**

- ❖ **KICKOFF MEETING  
PRESENTATION BY  
CONSORTIUM PARTNERS:**
- **ORBIT TECHSOL INDIA  
PRIVATE LIMITED, DELHI**
- **RBH SOLUTIONS PRIVATE  
LIMITED, PATIALA, PUNJAB**
- **SHAURYA ENTERPRISE,  
SHILLONG, MEGHALAYA**

**ADMS  
PROJECT  
OVERVIEW**

- ❖ **Direct Customer : North Eastern Region  
Power Committee (NERPC)**
- ❖ **End Customer / Beneficiary/Constituents:  
Electrical Utilities of the States of  
Arunachal Pradesh, Assam, Manipur,  
Meghalaya, Mizoram, Nagaland & Tripura**
- ❖ **LOA Date : 04.JUNE.2019**
- ❖ **LOA Value: INR 8,34,56,000.00 excluding  
GST ( INR Eight Crore Thirty Four Lakhs  
Fifty Six Thousand Only)**
- ❖ **Project Duration: 9 Months from the Date  
of Letter of Award (LOA)**
- ❖ **Warranty: 03 Years from the Date of Go  
Live / Taking Over**

Consortium  
Lead Partner:  
ORBIT Techsol  
India Pvt Ltd.

- ❖ Leading independent IT Infrastructure & Communication Solutions group in India : Incorporated in 1993
- ❖ Global head quarter is in Singapore. PAN INDIA presence with operations in Delhi & NCR, Chandigarh, Kolkata, Bangalore, Chennai, Hyderabad, Jaipur, Pune, Mumbai, Goa & Shillong
- ❖ Business Strength : Orbit Group Turnover - 250+ Crore Turnover in India
- ❖ By combining expertise in computing, networking, audio visual, security, storage and software's, with advanced skills in consulting, integration and managed services, we are end-to-end solutions providers
- ❖ Strategic alliance with leading IT & power automation OEMs
- ❖ SCADA & Communication Consultant : Power Automation Solution SI

ISO: 9001-2015 Certified

www.orbitindia.net | IT & Power Automation



Consortium  
Partner :RBH  
Solutions Pvt  
Ltd.

- ❖ Product based Automation Solutions provider
- ❖ Domain Expertise
  - Automation: Monitoring & Control System
  - Automation Communication Technologies
  - Automation Simulation & Test Platforms
  - SMART Grid Interfaces
  - IoT Connectivity
- ❖ Provides solutions for SMART Grid Communication Solutions and Smart Grid SCADA Solutions
- ❖ More than 450 SCADA Installations
- ❖ More than 4500 Installations of FRTUs / Gateways / DCUs
- ❖ 5 Indigenously developed different products to cover all Grid's End to End Requirements (1 – 6: Generation to Consumption)



ISO: 9001-2008 Certified

Consortium  
Partner :  
Shaurya  
Enterprise

- ❖ Leading Business Associate with interest in various technology domains including IT Data Centre Construction, IT Equipment's Supply & Services and Power Automation
- ❖ Strength : IT & Power Automation Project Services
- ❖ ADMS Project Responsibility: Site Activities Management, Project Implementation & Coordination
- ❖ Business Development & Local Project implementation for Consortium business Interest in IT & Power System domain in NER



ADMS System  
Architecture

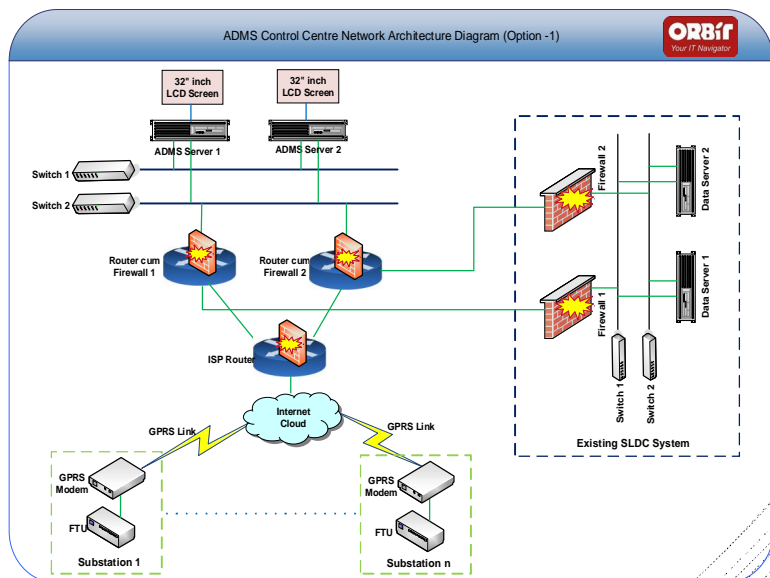

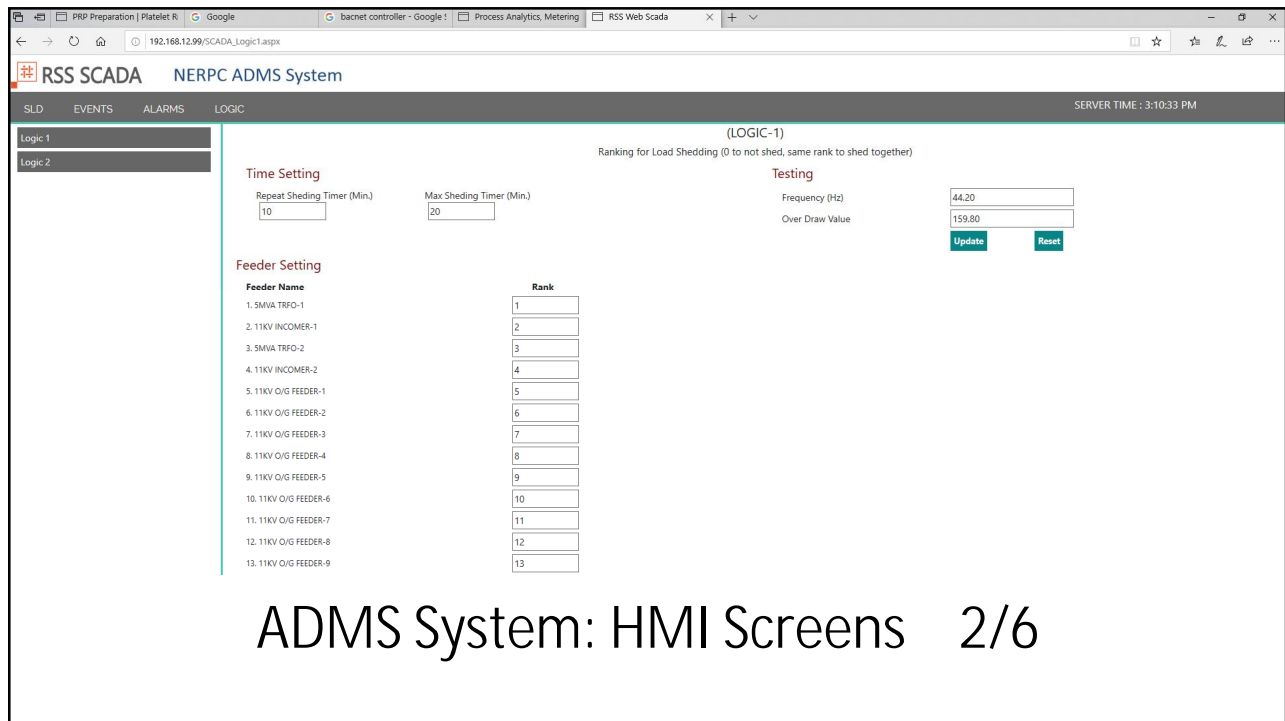
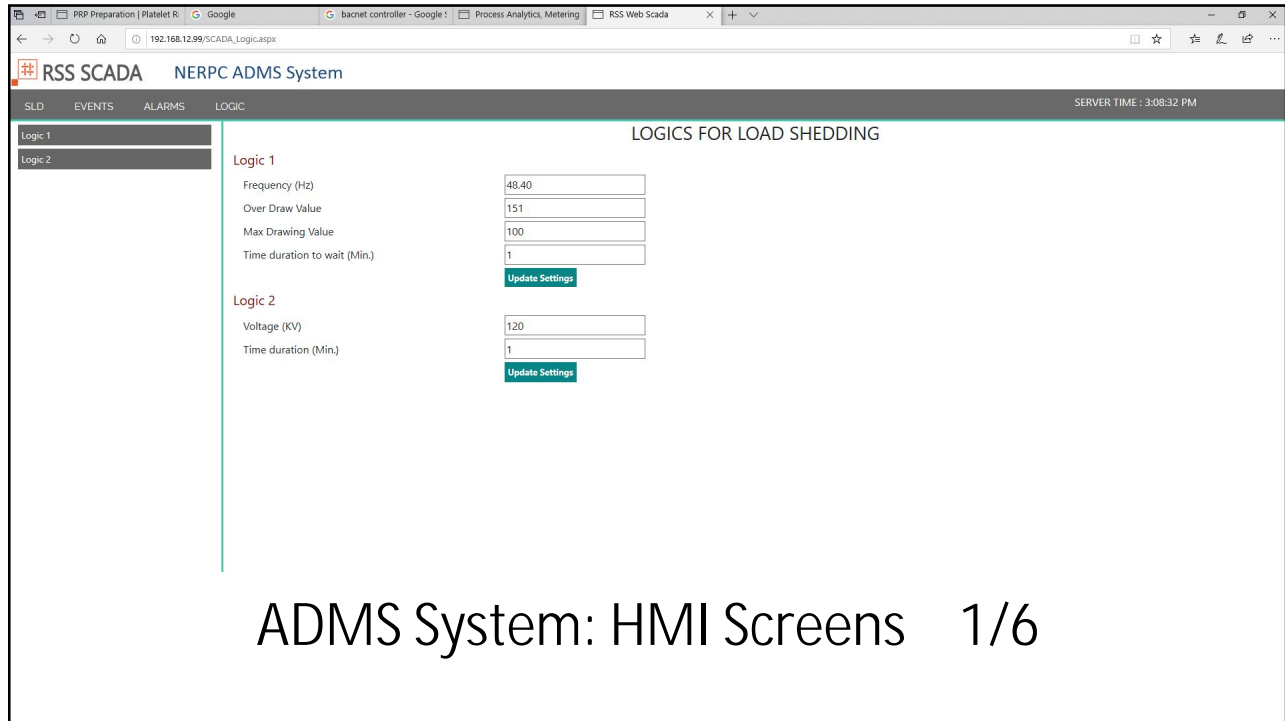



RSS SCADA NERPC ADMS System

SLD EVENTS ALARMS LOGIC SERVER TIME : 3:13:40 PM

All Stations

Circuit Title All Start Date 3 June 2019 Start Time 00 00 End Date 4 June 2019 End Time 00 00 Export Report

Date Time	Circuit Name	DI/AI Name	Status
6/3/2019 3:11:28 PM	SS-1_11KV INCOMER-1	CB STATUS	OPEN
6/3/2019 3:11:28 PM	SS-1_5MVA TRFO-1	CB STATUS	CLOSE
6/3/2019 3:10:39 PM	<System>	FRTU	CONNECTED
6/3/2019 3:09:48 PM	SS-1_11KV INCOMER-1	CB STATUS	UNKNOWN
6/3/2019 3:09:48 PM	SS-1_5MVA TRFO-1	CB STATUS	UNKNOWN
6/3/2019 3:09:48 PM	<System>	FRTU	DISCONNECTED
6/3/2019 3:02:52 PM	SS-1_5MVA TRFO-1	CB STATUS	CLOSE
6/3/2019 3:01:53 PM	SS-1_11KV INCOMER-1	CB STATUS	OPEN
6/3/2019 3:01:53 PM	SS-1_5MVA TRFO-1	CB STATUS	OPEN
6/3/2019 3:01:31 PM	<System>	FRTU	CONNECTED
6/3/2019 2:18:53 PM	SS-1_11KV INCOMER-1	CB STATUS	UNKNOWN
6/3/2019 2:18:53 PM	SS-1_5MVA TRFO-1	CB STATUS	UNKNOWN
6/3/2019 2:18:53 PM	<System>	FRTU	DISCONNECTED
6/3/2019 1:59:34 PM	SS-1_11KV INCOMER-1	CB STATUS	CLOSE
6/3/2019 1:59:30 PM	SS-1_5MVA TRFO-1	CB STATUS	CLOSE
6/3/2019 1:59:26 PM	SS-1_5MVA TRFO-1	CB STATUS	OPEN
6/3/2019 1:59:20 PM	SS-1_11KV INCOMER-1	CB STATUS	OPEN
6/3/2019 1:57:35 PM	SS-1_11KV INCOMER-1	CB STATUS	CLOSE

RSS SCADA NERPC ADMS System

SLD EVENTS ALARMS LOGIC SERVER TIME : 3:15:00 PM

All Stations

ALARMS

Circuit Title All

Date Time	Circuit Name	DI/AI Name	Status	Category
6/3/2019 3:11:28 PM	SS-1_5MVA TRFO-1	CB STATUS	CLOSE	NORMAL
6/3/2019 3:11:28 PM	SS-1_11KV INCOMER-1	CB STATUS	OPEN	CRITICAL#CB
6/3/2019 3:10:39 PM	<System>	FRTU	CONNECTED	NORMAL
6/3/2019 10:36:11 AM	<System>	GRID_OPC_0012	DISCONNECTED	CRITICAL

ADMS System: HMI Screens 6/6

## Key Milestones of Project Execution

S.No.	Activity	Month		Month: From LOA	Action Responsibility	Remarks
		From	To			
1	LOA Award & Kickoff Meeting	June,19	June,19	M0	ORBIT Consortium & NERPC & Constituent	Constituent: Electricity Utility of the State
2	CPG Submission	June,19	June,19	M0	ORBIT	
3	Site Survey	June,19	July,19	M1	ORBIT Consortium, NERPC & Constituent	7 SCADA Control Center & 34 Nos. Sub-Stations ( Total in all 7 States of NER)
4	Engineering Document Submission	June,19	July,19	M0-M1	ORBIT Consortium	
5	Payment against Engineering Document Submission	July,19	Aug,19	M1-M2	NERPC & Constituents	
6	Material Inspection & Dispatch	Sep,19	Sep,19	M4	ORBIT	All Constituents material Inspection & Dispatch
7	Material Delivery & Verification at all Sites	Sep,19	Oct,19	M5	ORBIT, NERPC & Constituents	
8	Invoice Processing & Payment Release against material Delivery at all sites	Oct,19	Nov,19	M5-M6	NERPC & all Constituents	
9	Installation of ADMS System HW at SLDCs & Integration Testing	Nov,19	Dec,19	M6-M7	ORBIT Consortium	
10	Data Interface Testing on OPC/CCP/Any other suitable protocol SLDC Server/selected Machine & ADMS Server	Nov,19	Nov,19	M6-M7	ORBIT Consortium & Constituent	
11	I&C at S/S ( All States - Total 34 Sites) & Data Integration testing with respective CC	Nov,19	Dec,19	M5-M6	ORBIT Consortium & Constituent	2-3 Team in Parallel at various S/S
12	ADMS System SAT	Dec,19	Jan,20	M7-M8	ORBIT Consortium & Constituent	Testing of SW Functions & Data communication among FTU, ADMS System & SLDC Server
13	Training	Nov,19	Jan,20	M6-M8	ORBIT Consortium, Constituent & NERPC	
14	System Handing Over/Taking Over Certificate/Go Live	Feb,20	Feb,20	M9	NERPC	System Handover to all Constituents progressively immediately after completion of System SAT
15	Final Payment Release	Feb,20	March,20	M9-M10	ORBIT Consortium, NERPC & Constituent	
16	Commencement of Support Period ( For 3 Years)	March,20	Feb,23	For 3 Years	Orbit Consortium	

Support requested from NERPC & Constituents 1/3

### ❖ Sites Survey ( Control Centre & Sub-Stations)

- Identification of S/S with their locations under each State
- contact details of S/S In charge for S/S Survey coordination & Survey report joint validation
- Nomination of Coordinating Officer from each constituent/State for all Sites Survey & Validation
- Finalization of CC & S/S Survey Schedule

### ❖ Documents Approval :Coordinating Officer of NERPC for submitted documents approval

- **Payment Processing** : Nomination of NERPC officer for Invoice processing with recommendation for payment by respective Constituent, Nomination of State official for Invoice processing & release of payment against each payment milestone

Support  
Requested from  
NERPC &  
Constituents 2/3

❖ **OPC Access & Data Availability**

- Ref to NER EMS SCADA Specification as below, OPC shall be enabled at concerned SLDC Servers/machines of all states of NER:
  - **SPECIFICATION VOL II-PART B – SECTION 1 – SCADA SYSTEM FUNCTION – CLAUSE 1.2.3 (DATA EXCHANGE) & CLAUSE 1.8.4 (ISR)**
  - **SPECIFICATION VOL II-PART B – SECTION 4 – SYSTEM SOFTWARE REQUIREMENTS – CLAUSE 4.7.5 (DATA EXCHANGE UTILITIES)**

❖ **Expected supported action from GE/Constituents**

- OPC access shall be provided from concerned Servers in redundant configuration of existing NER EMS SCADA System at each State SLDC.
- Enable OPC Server tool in CFE/Other applicable Servers.
- Configure processor starter and Add OPC App process
- Add OPC Server in Data Source and Data Sets in existing Database
- Add required Database points in data sets of corresponding Sub-Station
- Required data points : Grid Frequency, Load Conditions, Grid Voltages etc. or any other information based on Load Shedding Algorithms shall be configured as Data Points for the OPC Data Base.

Support  
Requested from  
NERPC &  
Constituents 3/3

❖ **Data Access through Firewall of existing SLDC under NER EMS SCADA System**

- Establish the connection through firewall and allow communication port 5020 in between SCADA LAN and ADMS LAN
- Allow the NTP port 123 in firewall for time synchronization of ADMS Servers, Switches and Routers

❖ **Availability of Data SIM with Static IP & Leased Line Connections at SLDC with Static IP ( Contractor responsibility for duration of Testing & System Commissioning period only)**

- SIMs & Leased Line connection will probably be issued by Telecom Service provider on local ID of constituents only.
- Constituent shall facilitate the administrative support for acquiring the same & contractor shall pay its charges till system commissioning completion.

**Consortium :  
Project  
Coordination &  
Management**

❖ Orbit Techsol India Pvt Ltd.

- Project Management : Rajesh Bhargava
- M: +91 99580 95107
- E-Mail: rajesh.bhargava@orbitindia.net

❖ RBH Solutions Pvt Ltd.

- Technical Management : Birinder Singh
- M: + 91 98728 07437
- E-Mail: birinder@rbhsolutions.com

❖ Shaurya Enterprise

- Site Management : Shakti Laitphlang
- M: +91 98625 76277
- E-Mail: shakti.laitphlang@shauryaenterprise.net

**• THANKS !**

**• Q & A ?**

**SAMAST implementation in NER States:**

**Tripura**

1. Open access regulation as published by TERC '[Terms and Condition of Open Access Regulation, 2010](#)' on 15-07-2011.
2. Website of TERC is [www.terc.nic.in](http://www.terc.nic.in).
3. Open Access Customer are approaching to TSECL for connectivity & agreement. Customer like 'Tripura Ispat', N K Cement etc. – which are small industries has already communicated with TSECL for their connectivity as open access customer.
4. Tripura State Electricity Corporation Limited has been established and started work 1<sup>st</sup> January 2005 onwards and Tripura Power Generation Limited has been established and started work 1<sup>st</sup> Sept.2016 onwards.
5. Tripura has five generating Stations under TPGL named Gumati, Baramura, Rokhia, Monarchak(Gas) and Monarchak(Solar).
6. Tripura SLDC is under TSECL (STU) and it is likely to carry out DSM Accounts of its prospective Open Access customers, once connected.

**Manipur**

1. Electricity Deptt., Govt. of Manipur was unbundled as per transfer scheme 2013 issued vide notification no. 5/5/2011-Power dated 31.12.2013. Two corporations were formed namely Manipur State Power Corporation Ltd. (MSPCL) and Manipur State Power Distribution Co. Ltd. (MSPDCL).
2. SLDC is under MSPCL (STU). A Society has been formed to make SLDC independent.
3. Manipur Joint Electricity Regulatory Commission (JERC) in its co-ordination forum meeting dated 19.06.2018 noted implementation of SAMAST and decided to stall all 15 minutes meter procurement in intra-State to enable install 5 minute meters under SAMAST (copy attached).

4. JERC has issued Open Access Regulations which is applicable to both Manipur and Mizoram. <https://jerc.mizoram.gov.in/page/notified-regulations1549550266>
5. Small Industries are approaching MSPDCL for allowing Open Access.
6. Manipur is a lead State for reforms and is the first State in India to do pre-paid metering for 90% of its consumers.

### **Nagaland, Mizoram and Ar. Pradesh**

1. These three States are still with Electricity Departments and restructuring has not been done till now.
2. Nagaland Regulatory Commission has issued Open Access Regulations: [http://www.nerc.org.in/index.php?option=com\\_content&view=category&layout=blog&id=41&Itemid=2](http://www.nerc.org.in/index.php?option=com_content&view=category&layout=blog&id=41&Itemid=2)
3. Nagaland Regulatory Commission has issued Open Access Regulations: <http://www.apserc.nic.in/regulation.html>
7. Mizoram Regulatory Commission has issued Open Access Regulations: <https://jerc.mizoram.gov.in/page/notified-regulations1549550266>
4. Mizoram has own generating Station Tuirial HEP.
5. Nagaland has own generatin Station Likimaro HEP
6. Arunachal Pradesh has four Open access customers for whom, SERC has advised SLDC to prepare DSM Accounts.

Sl. No.	Name of Open Access	Location	Remarks
1	Shree Salasar Industry Pvt. Ltd	Lekhi	
2	Platinum Alloy Pvt. Ltd.	Tippi	
3	Satyam Ispat N.E Ltd	Banderdawa	
4	SMS Militus Ltd.	Lekhi	

7. Mizoram and Nagaland has prospective open access customers approaching the Deptt.

View of TESG for not allowing PSDF Grant for SAMAST in case of five States:

1. Single DISCOM system.
2. Less no. of intra-State players

As on date, all seven States of NER are with single DISCOM system.

As per note prepared for the five States of NER, it can be seen that system is emerging in all the States and in addition to Assam, Meghalaya, restructuring has been completed in case of Manipur and Tripura.

In all the States, SERC has issued relevant Regulations for DSM Accounts of STOA customers.

Even State like Arunachal Pradesh is dealing with four Open Access customers.

Extract of SAMAST report is as below:

***QUOTE***

*Section 28 and 32 of the Electricity Act 2003 mandate that the Load Despatch Centre shall schedule in accordance with the contracts and keep account of electricity transmitted through the transmission grid. This implies that a 'ledger' of energy transactions have to be maintained, the physical flow of electricity across various notional seams in the electricity grid have to be measured and 'energy balance sheets' have to be prepared at the transmission level.*

*The objective of this endeavor was to assimilate the available experience at the interstate/intrastate level and suggest a uniform procedure for SAMAST across all the States and Regions in India whether renewable – rich or otherwise.*

***UNQUOTE***

The above makes it unambiguously clear that SAMAST has to be there in all States of the Country irrespective of conditions like size and numbers as keeping accounts of Electricity is a pre-requisite for all other things.

The States of North Eastern Region are making continual efforts to catch up with rest of the Regions and implementation of SAMAST will be a great boost in that direction.





उ.पू.क्षे ग्रिड प्रदर्शन

**NER GRID PERFORMANCE**

*For the month May, 2019*

**North Eastern Regional Load Despatch Centre**

***POSOCO, Shillong***

## Power Exchange Price during May'19

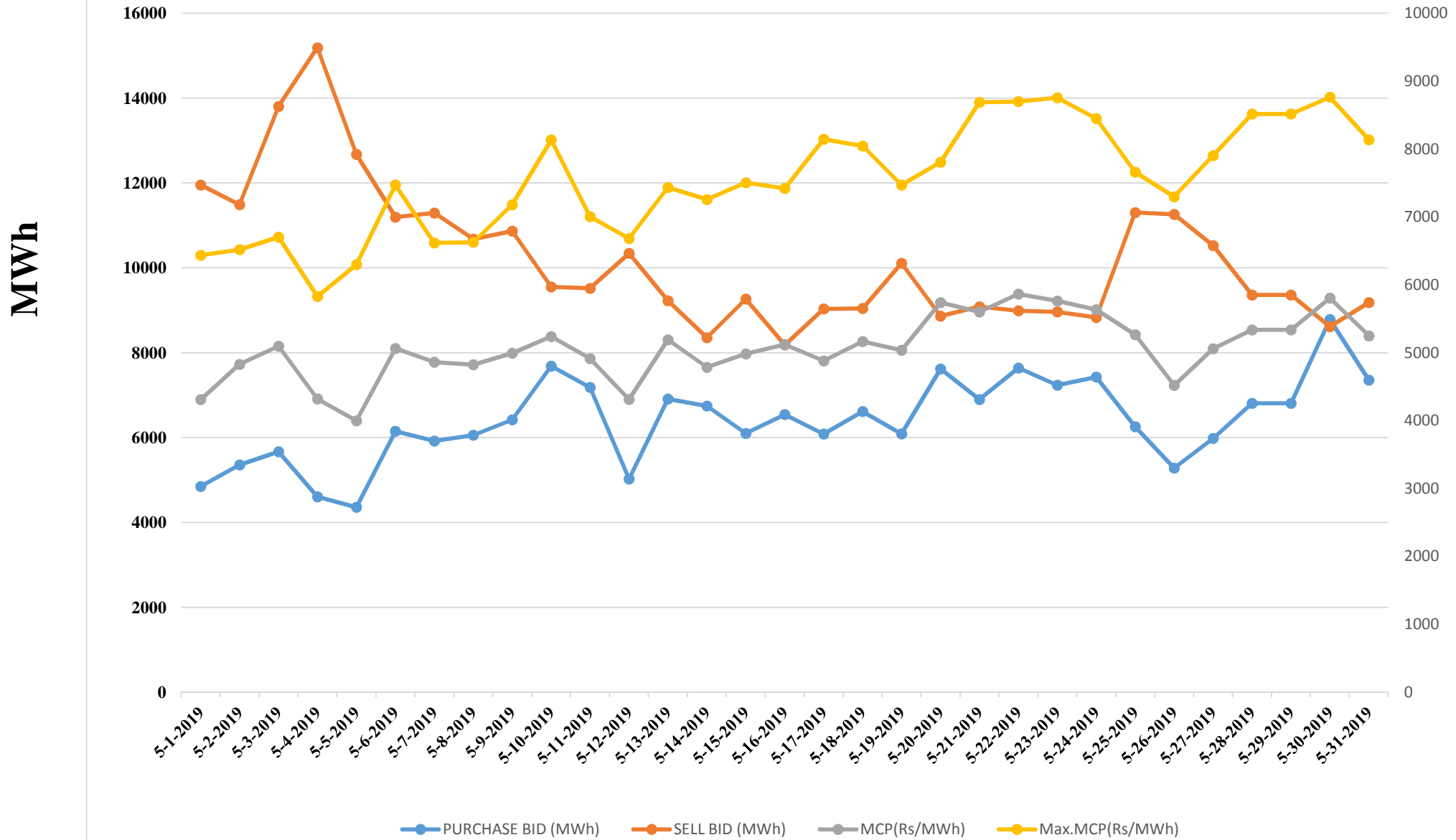

# Zero Crossing Violation - NER States during May, 2019

Total No Of Deviation

350  
300  
250  
200  
150  
100  
50  
0

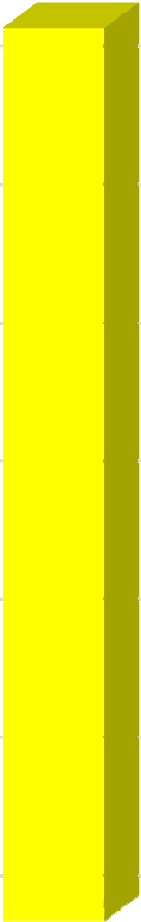

323

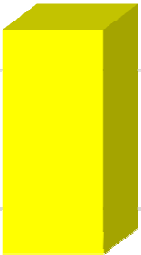

81

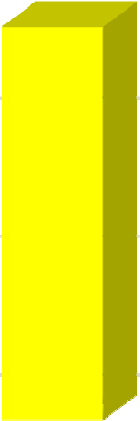

142



45

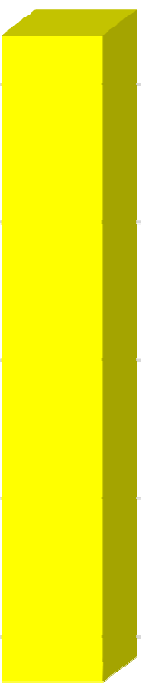

234



169



23

AP

ASSAM

MANIPUR

MEGHALAYA

MIZORAM

NAGALAND

TRIPURA

### Grid Disturbances and Grid Incidences of May

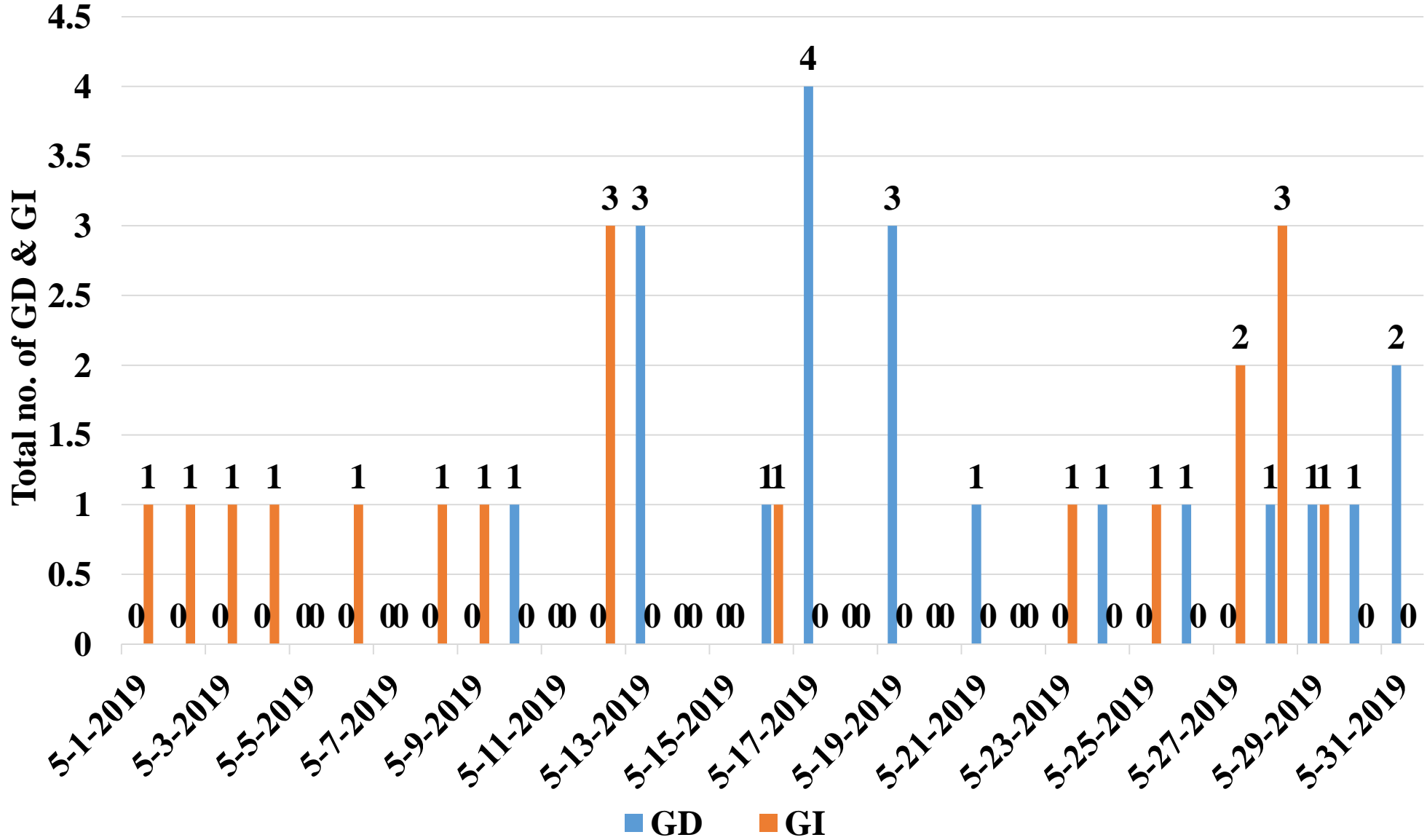

Total C

Total C

# FREQUENCY PROFILE OF MAY'2019

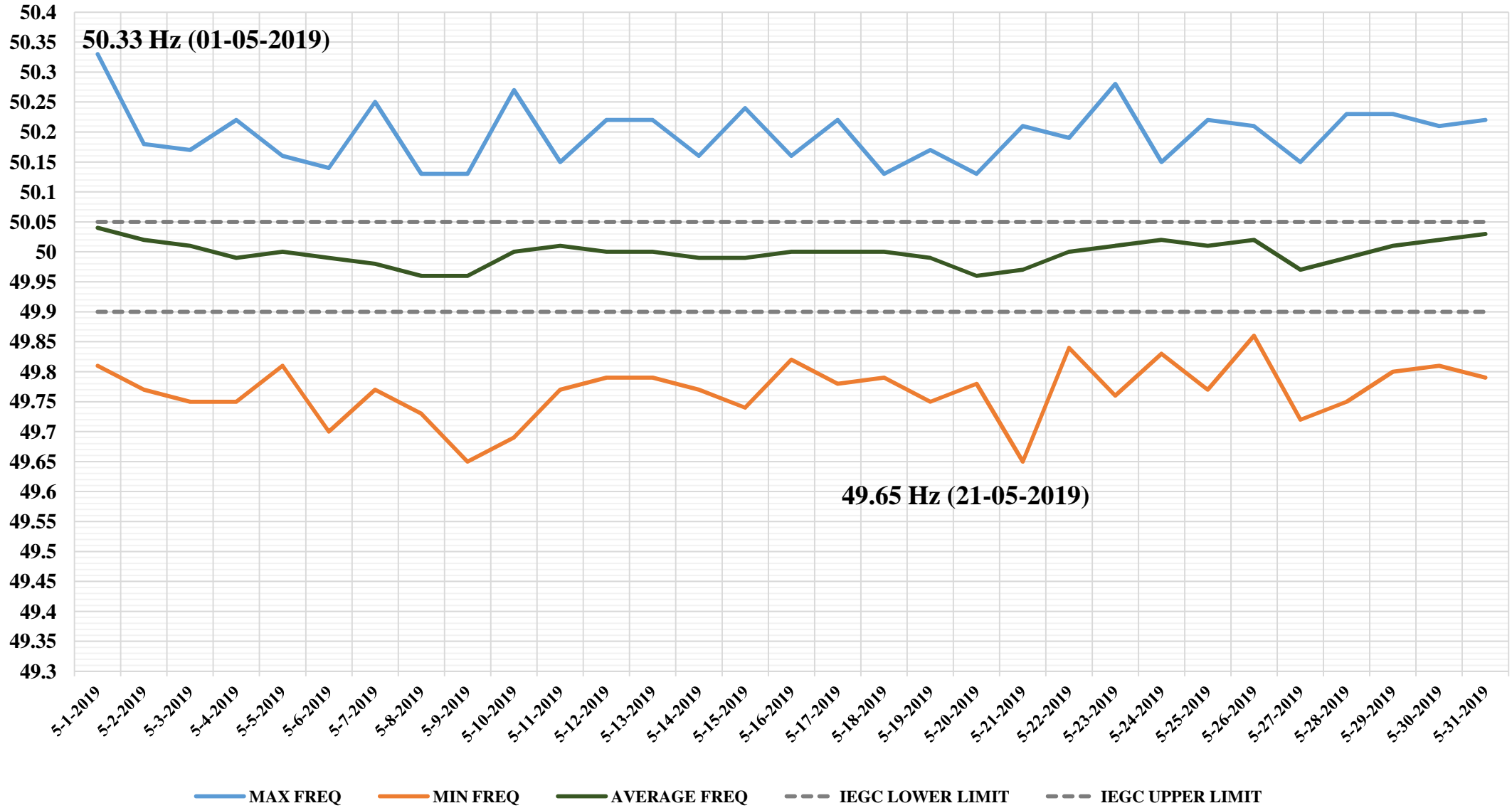







# Total Approved Shutdown during May, 2019

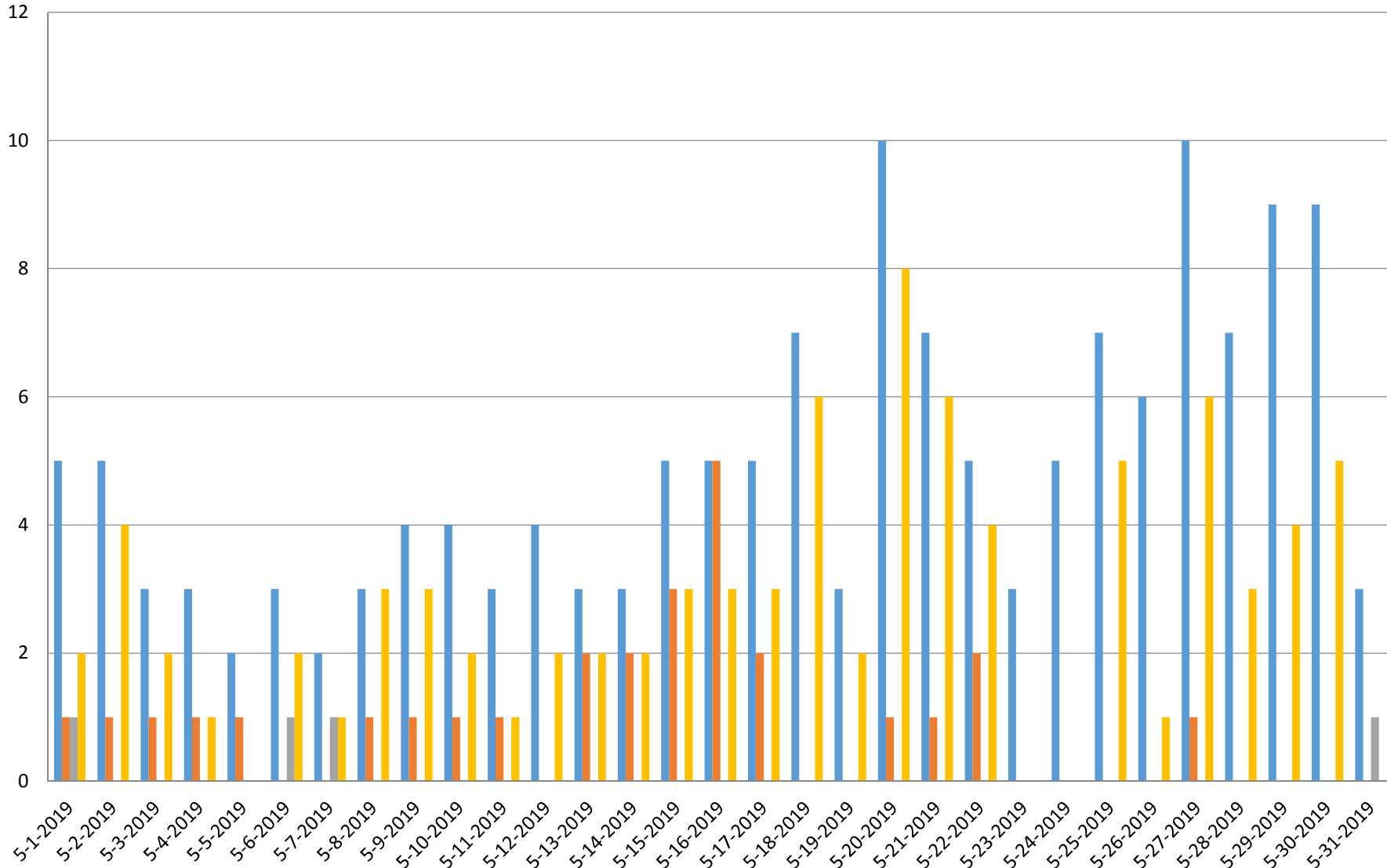

- OCC
- EMERGENCY
- NERPC
- TotalAvailed

**OCC: 153**  
**EMER: 28**  
**NERPC: 4**  
**TOTAL Aailed**







# Line Trippings during May'19

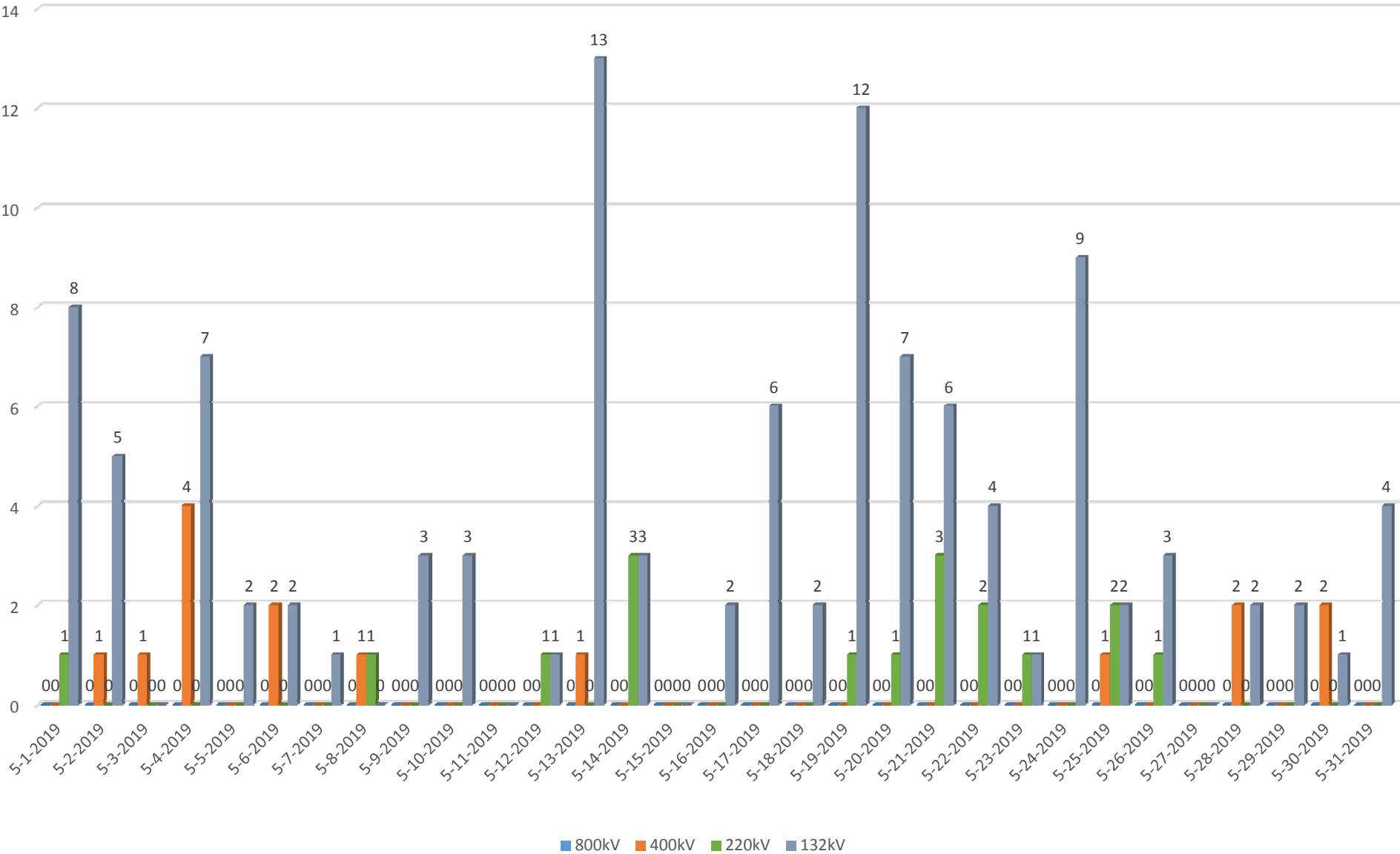

800 kV  
 400 kV  
 220 kV  
 132 kV  
**Total :**

## Present per day MU and projected number of days of operation

Plants	Reservoir Level in meters (as on 02/06/19)	MU Content	Present DC (MU)	No of days as per current Generation
Khandong + Kopili STG II	714.95	73.022	0.668+0.519	60
			1.207	
Kopili	602.4	76.77650+ 4x73.022	3.486	106
		368.8645		
Doyang	306.609	7	0.135	52
Loktak	766.64	16	1.05	15

# Comparison of Telemetry Availability Statistics

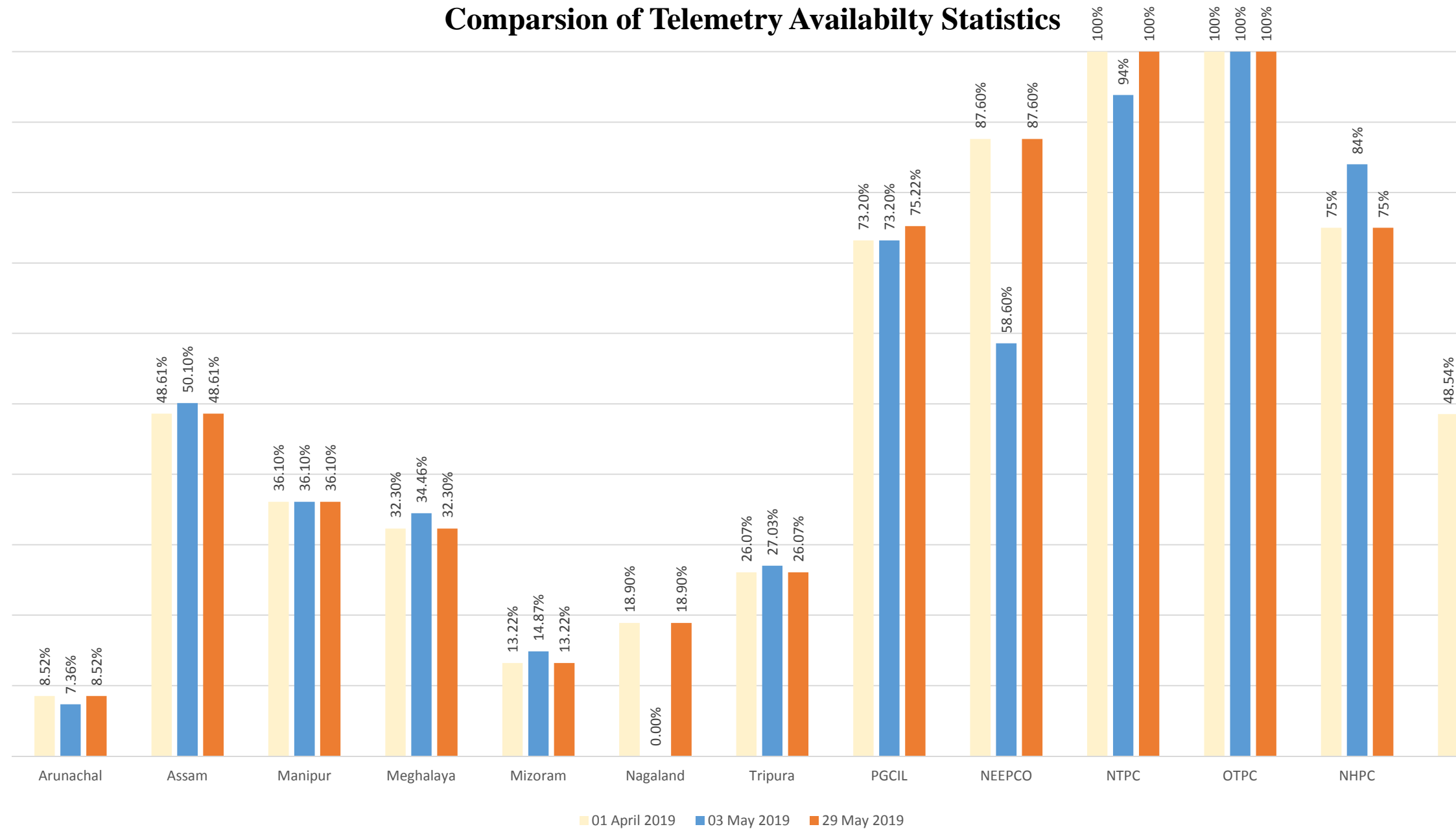

# TELEMETRY STATISTICS (as on 29.05.19)

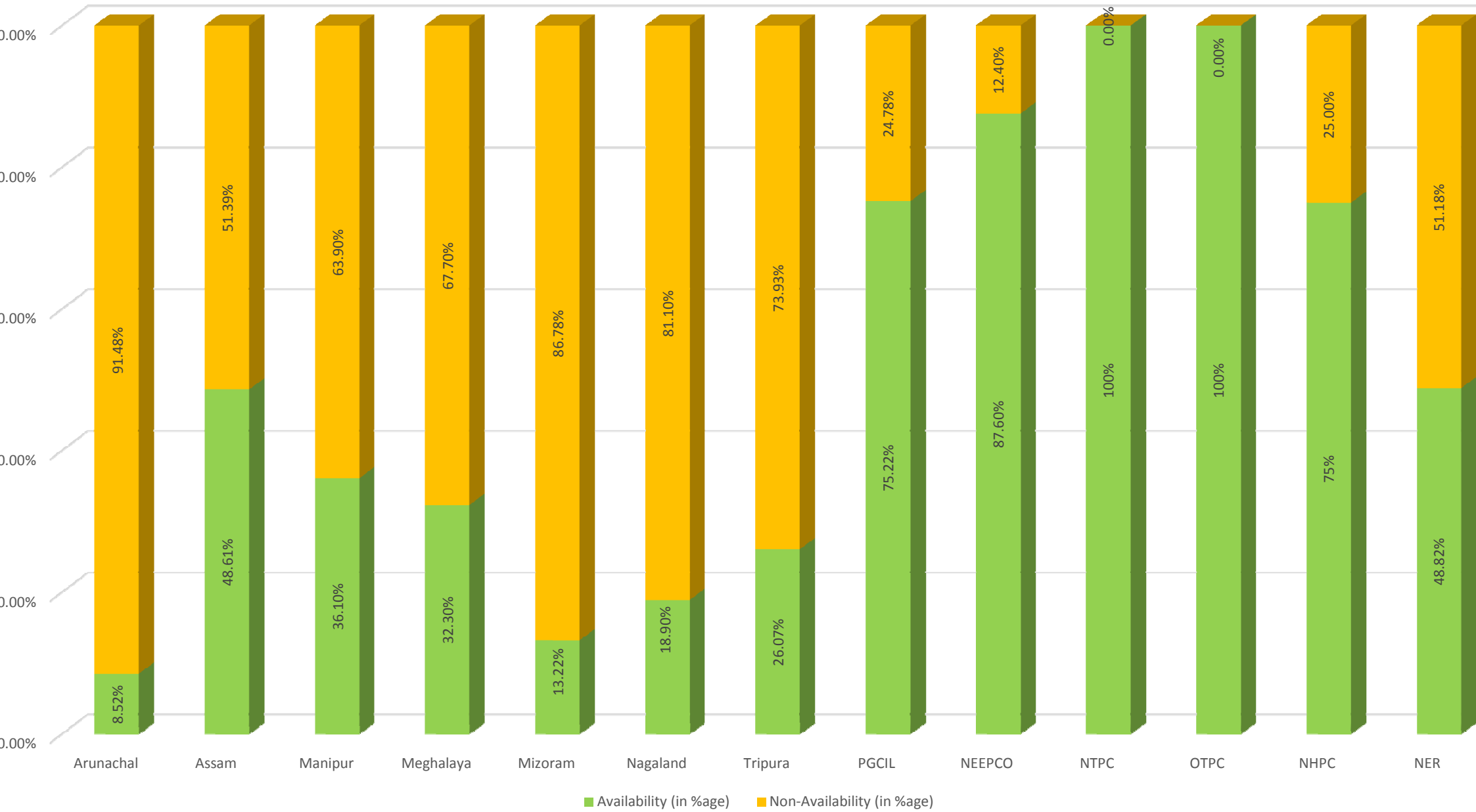

## Department Mail IDs of NERLDC for official Communication

Sl. No.		Email ID
1.	Departmental Communication	i) <a href="mailto:nerldcso1@posoco.in">nerldcso1@posoco.in</a> ii) <a href="mailto:nerldccr@posoco.in">nerldccr@posoco.in</a> iii) <a href="mailto:nerldcso2@posoco.in">nerldcso2@posoco.in</a> iv) <a href="mailto:nerldcmo@posoco.in">nerldcmo@posoco.in</a>
2.	Head of The Region	v) <a href="mailto:nerldcsl@posoco.in">nerldcsl@posoco.in</a> i) <a href="mailto:hor_nerldc@posoco.in">hor_nerldc@posoco.in</a>

- In addition to the personal mail ids the official communications to NERLDC has to be given to respective department mail IDs along with a copy to Head of the Region.

The background of the image is a light beige or tan color with a subtle, repeating pattern of small, brown, fish-like shapes. These shapes are arranged in a grid-like fashion, alternating between vertical and horizontal orientations. The fish are simple in design, with a rounded body and a small tail. The overall aesthetic is clean and minimalist.

THANK YOU



# **RGMO Analysis for the event dated 16.05.2019 at 19:10 Hrs**

Event Description : On 16th May 2019, at 19:10 hrs smelter load of Vedanta plant that is coming through Sterlite sub-station became nil as reported. The reason of the incident is still not being intimated by SLDC. Also in the incident, SCADA data of Sterlite station was suspected. The net change in power is calculated from remote end data of 400 kV lines connected to Sterilte station and that change is 1337 MW.

# Palatana

\*Data as per SCADA data

### PALATANA GTG 1

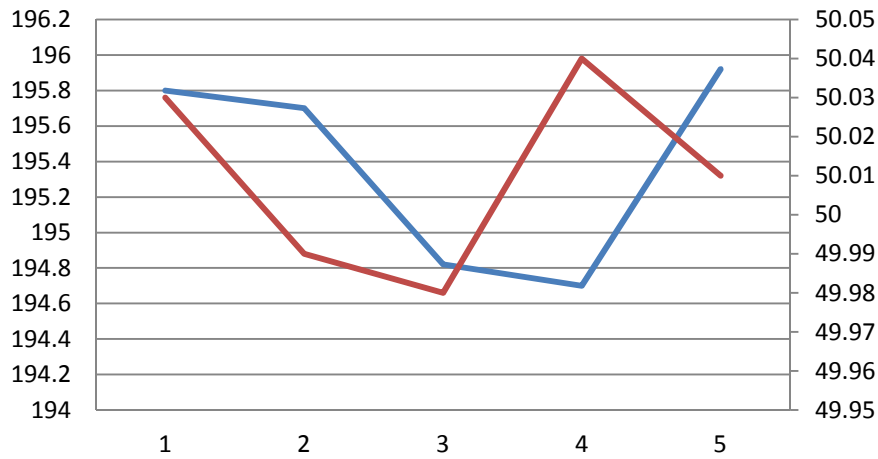

### PALATANA GTG 2

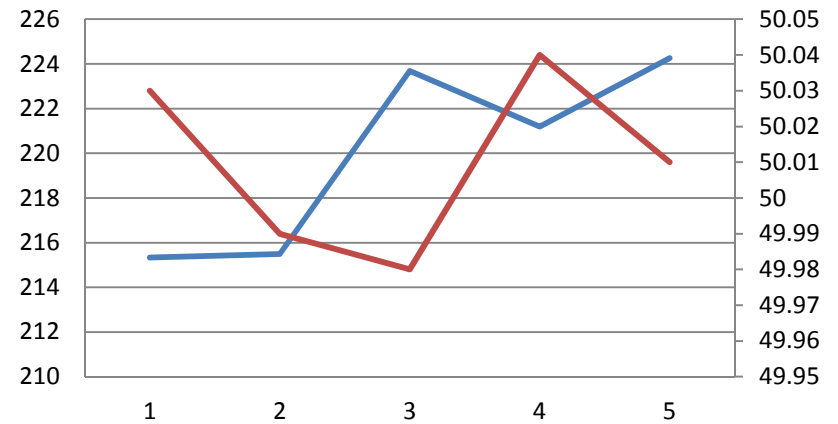

### Palatana STG 1

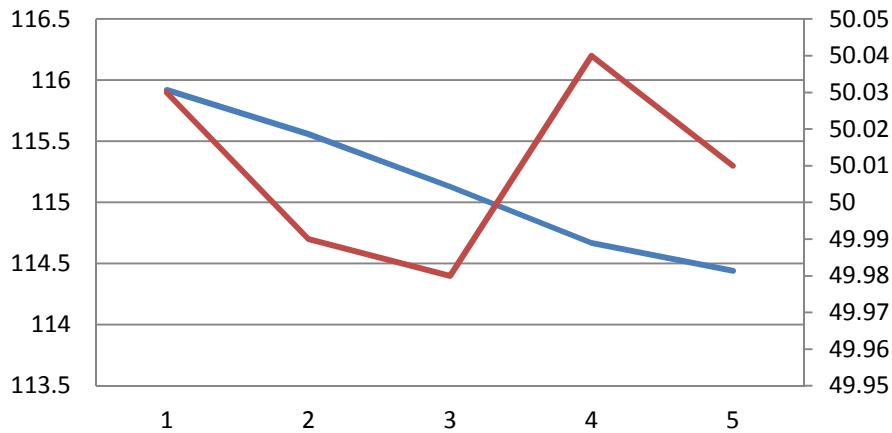

### Palatana STG 2

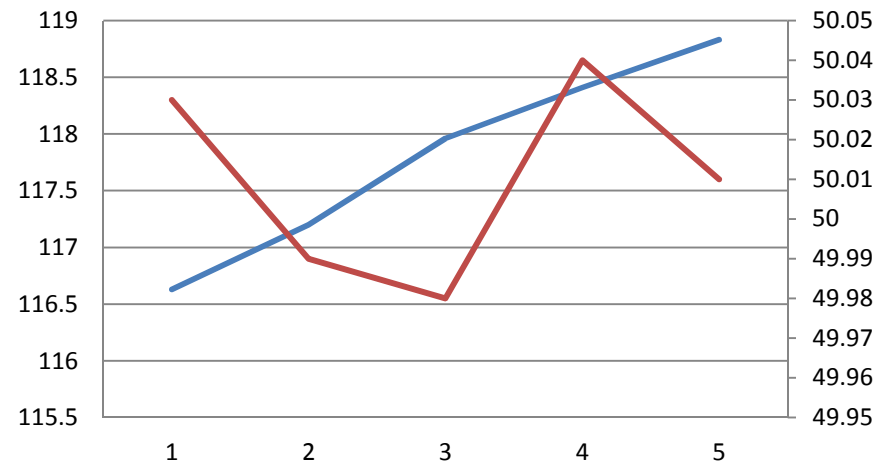

1- 19:08; 2- 19:09; 3- 19:10; 4- 19:11; 5- 19:12

— Freq — MW

# BgTPP

\*Data as per SCADA data

### BTPS Unit 1

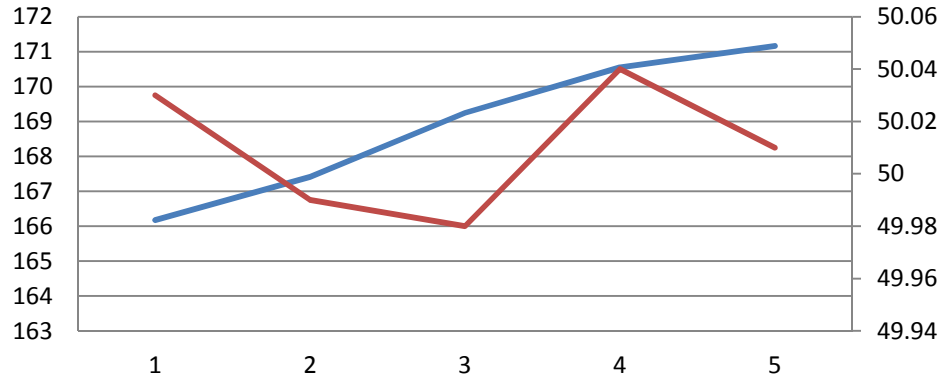

### BTPS Unit 2

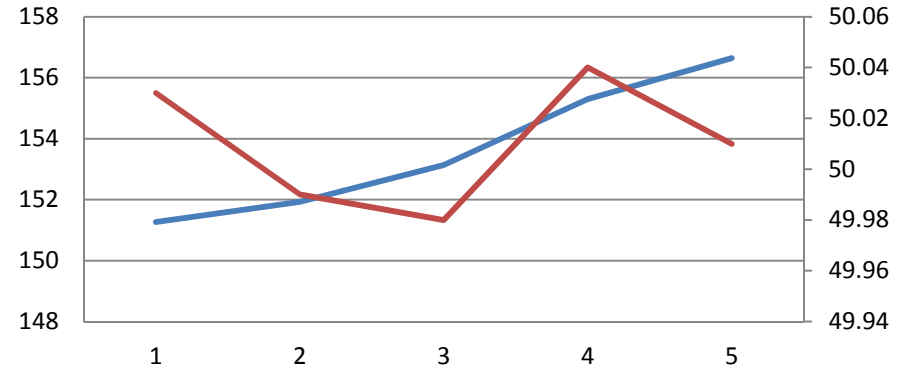

### BTPS Unit 3

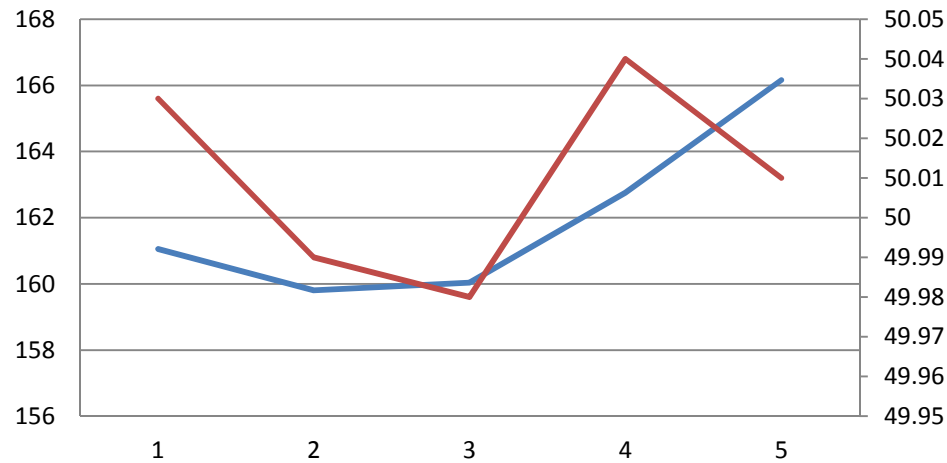

1- 19:08; 2- 19:09; 3- 19:10; 4- 19:11; 5- 19:12

— Freq — MW

# KOPILI

\*Data as per SCADA data

### Kopili Unit 1

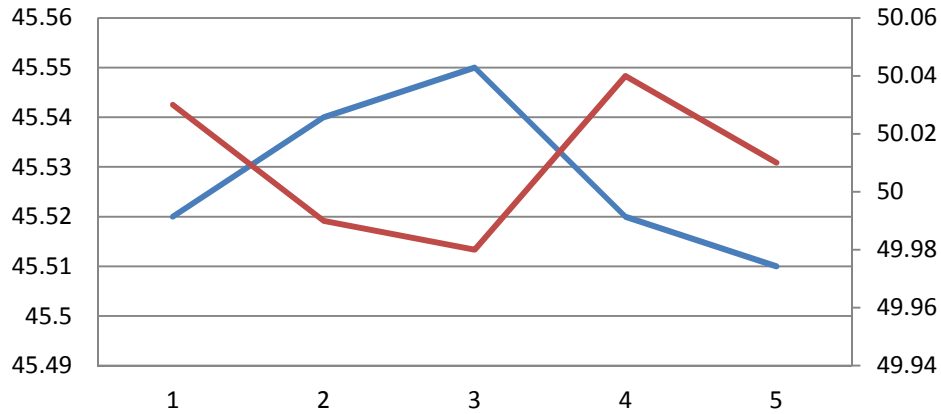

### Kopili Unit 2

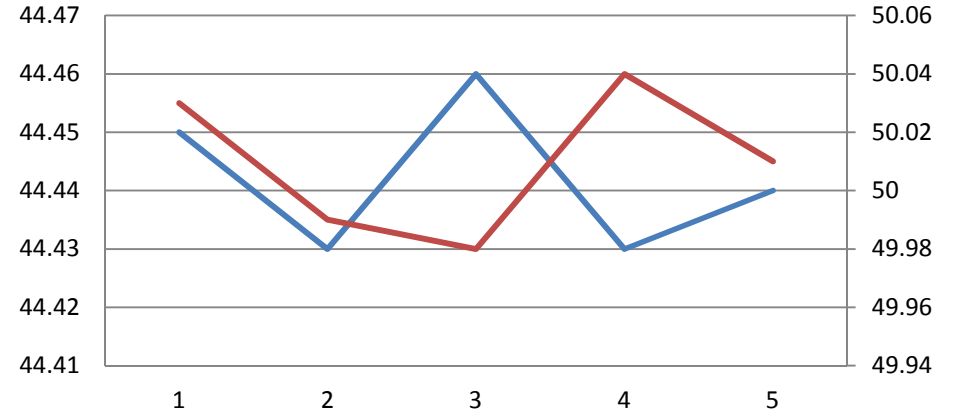

### Kopili Unit 3

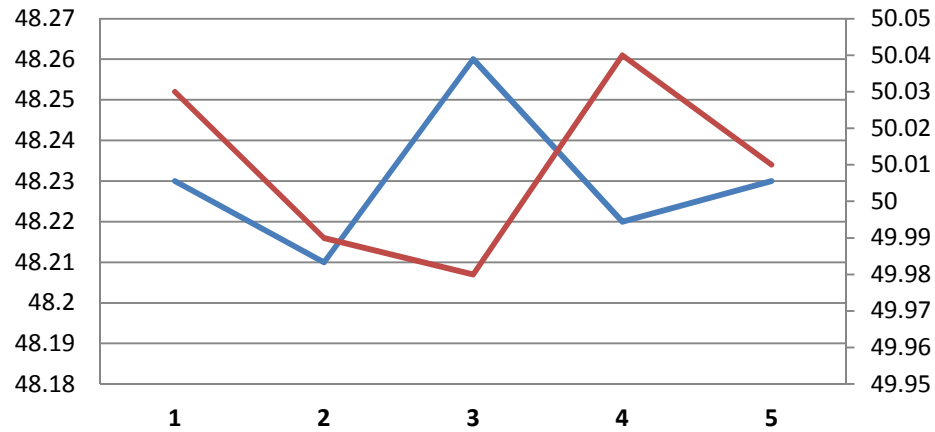

### Kopili Unit 4

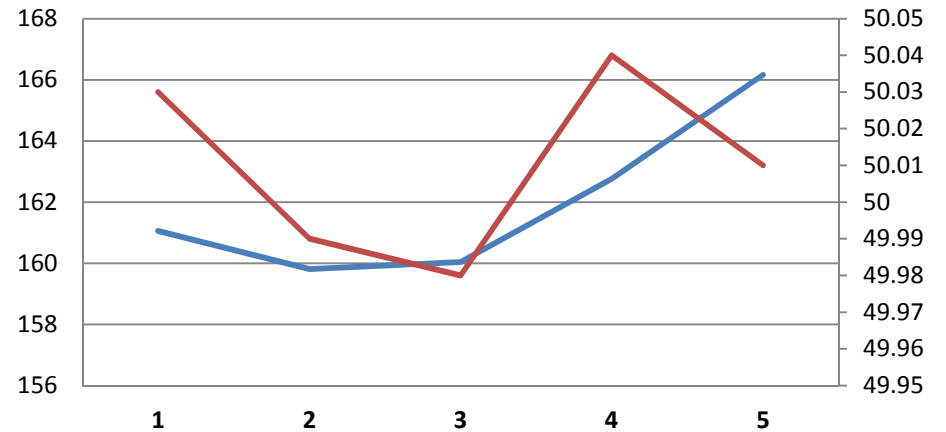

1- 19:08; 2- 19:09; 3- 19:10; 4- 19:11; 5- 19:12

— Freq — MW

# KHANDONG

\*Data as per SCADA data

## Khandong Unit 1

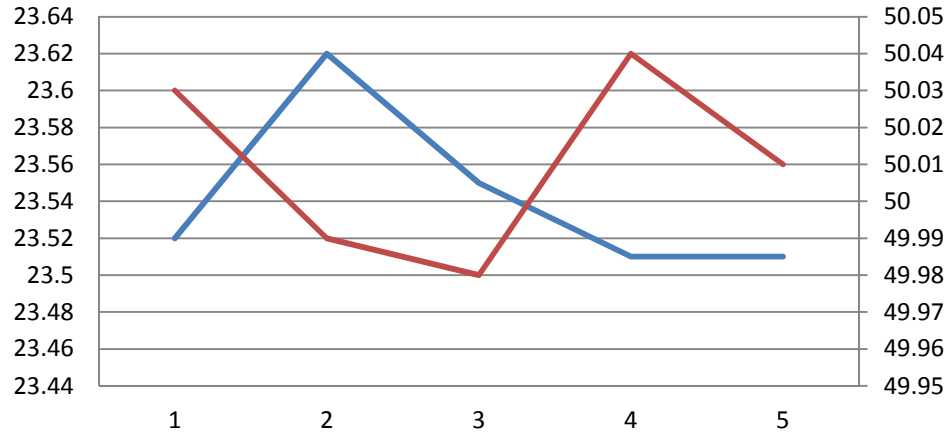

## Khandong Unit 2

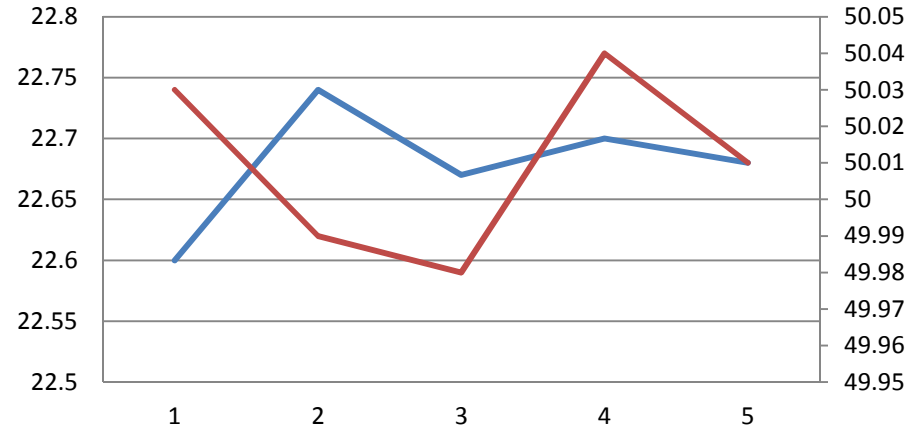

## Khandong Unit 3

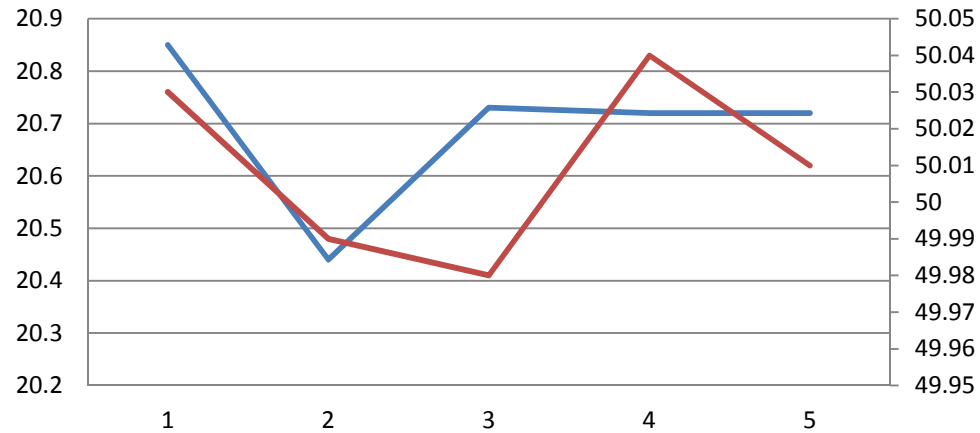

1- 19:08; 2- 19:09; 3- 19:10; 4- 19:11; 5- 19:12

— Freq — MW

# PARE & RANGANADI

\*Data as per SCADA data

### Pare Unit 1

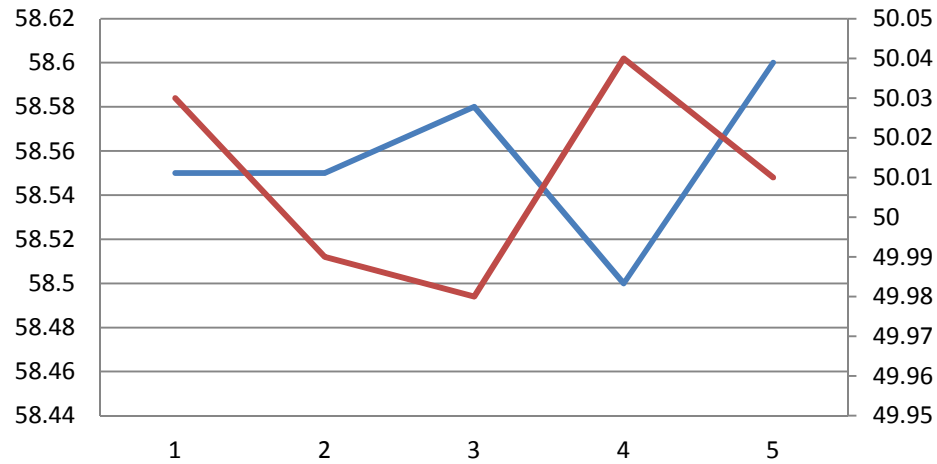

### Pare Unit 2

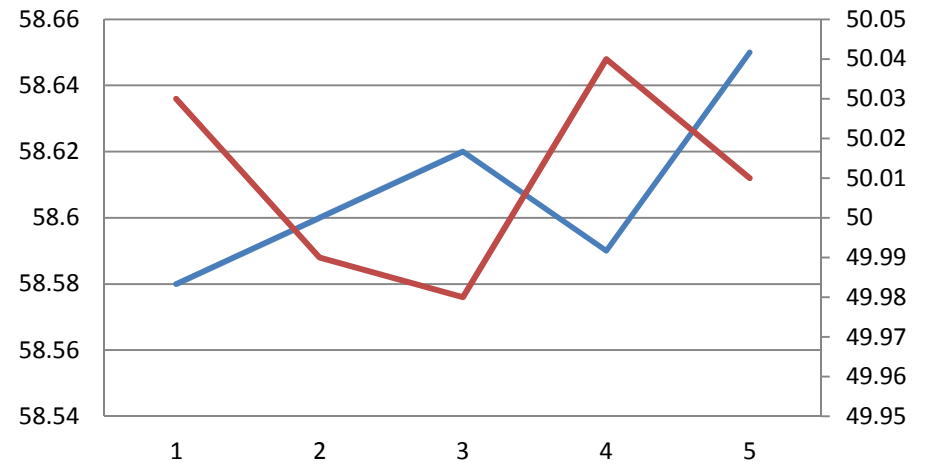

1- 19:08; 2- 19:09; 3- 19:10; 4- 19:11; 5- 19:12

— Freq — MW

# RANGANADI

\*Data as per SCADA data

### RHEP Unit 1

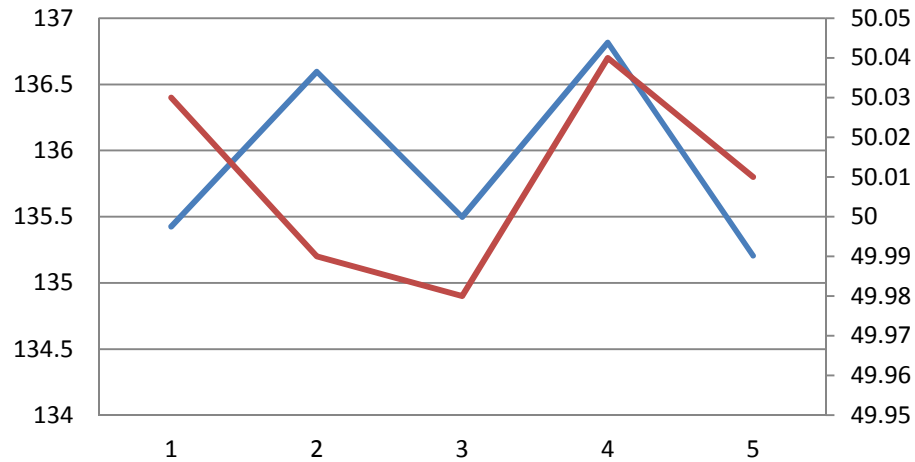

### RHEP Unit 2

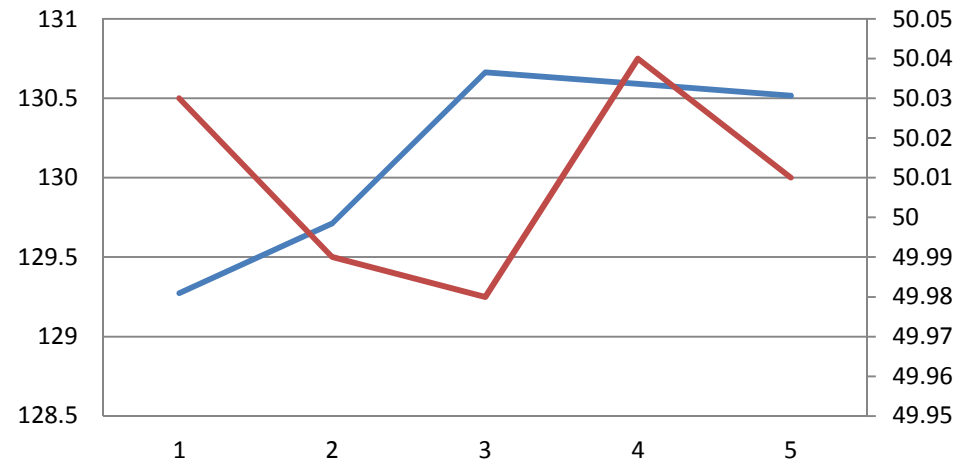

### RHEP Unit 3

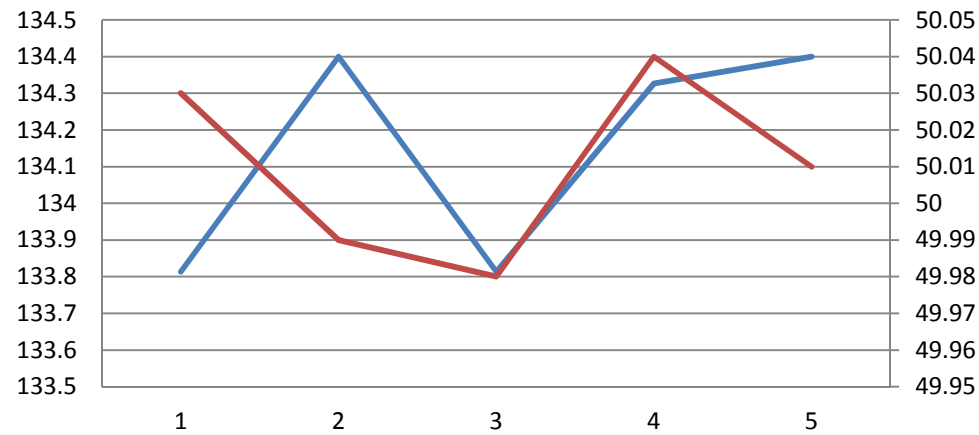

1- 19:08; 2- 19:09; 3- 19:10; 4- 19:11; 5- 19:12

— Freq — MW

# Actual Vs Ideal Response

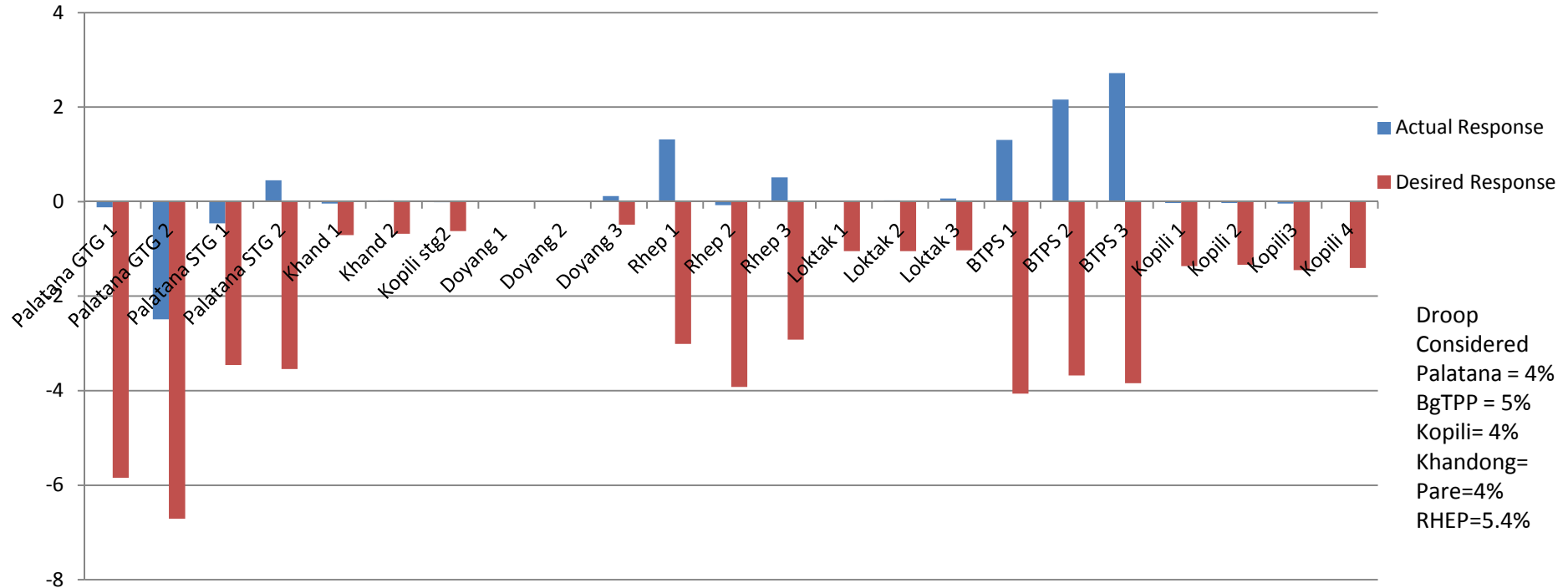

- Observations:

1. All generating units have given negative response (except Palatana GTG I,II; STG I, Kopili HEP and RHEP Unit 2, but response less than the desired response )

NERLDC



*THANK YOU !*



# **RGMO Analysis for the event dated 19.05.2019 at 10:35 Hrs**

Event Description : On dated 19-May-2019 at 10:35 hrs ,all units in operation i.e. unit 1- 4 & 6 of 210 MW each and Unit 7-10 of 500MW each at Vindhyachal STPS Stage-1, Stage-2 and Stage-3 tripped along with all 400kV Buses and emanating lines connected to VSTPS Stage-1, Stage-2 and Stage-3. As reported by NTPC, Due to R-phase bushing failure of generator transformer of Unit-7 and subsequent tripping of other units on impedance protection and turbine over speed. Around 2975 MW of generation loss occurred.

# Palatana

\*Data as per SCADA data

### PALATANA GTG 1

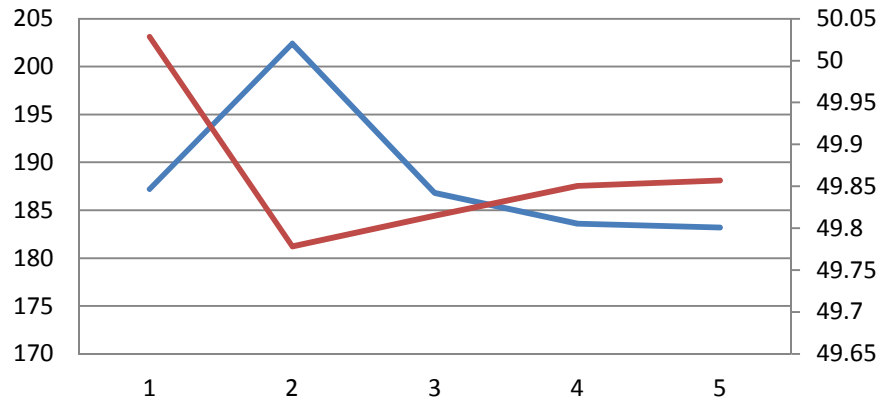

### Palatana STG 1

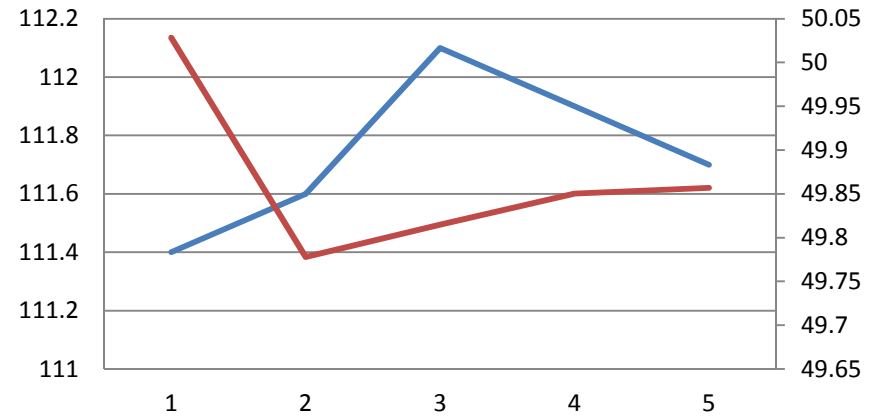

### PALATANA GTG 2

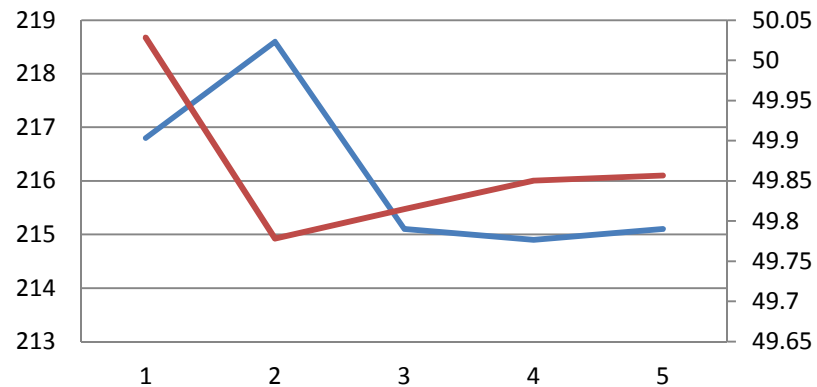

### Palatana STG 2

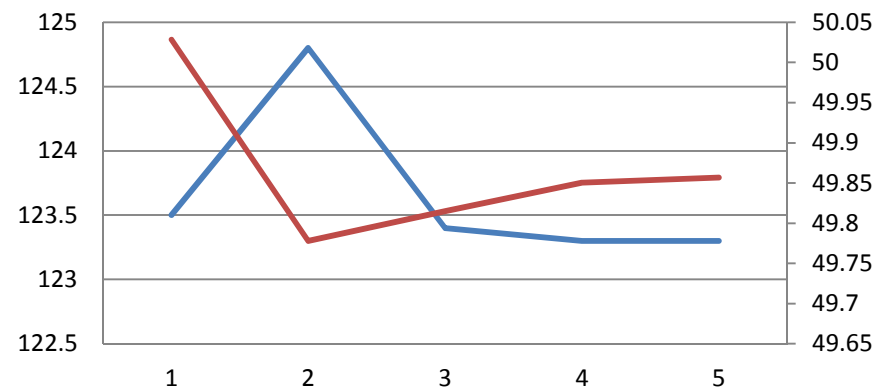

1- 10:35; 2- 10:36; 3- 10:37; 4- 10:38; 5- 10:39

— Freq — MW

# BgTPP

\*Data as per SCADA data

### BTPS Unit 1

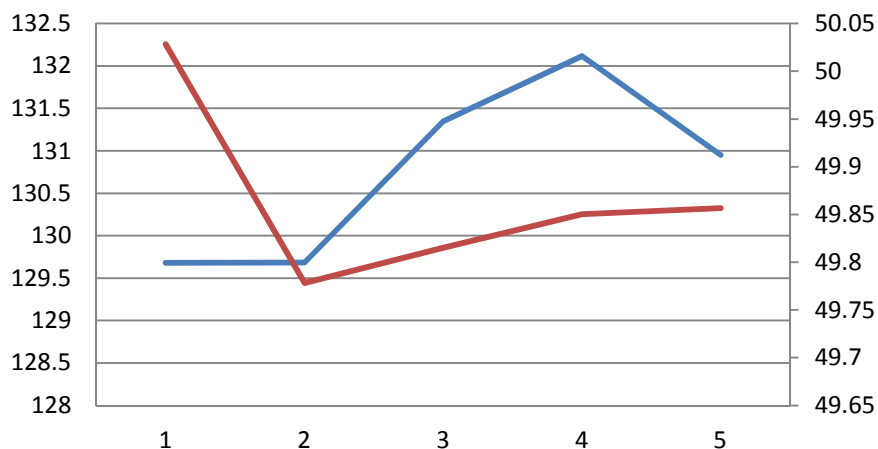

### BTPS Unit 2

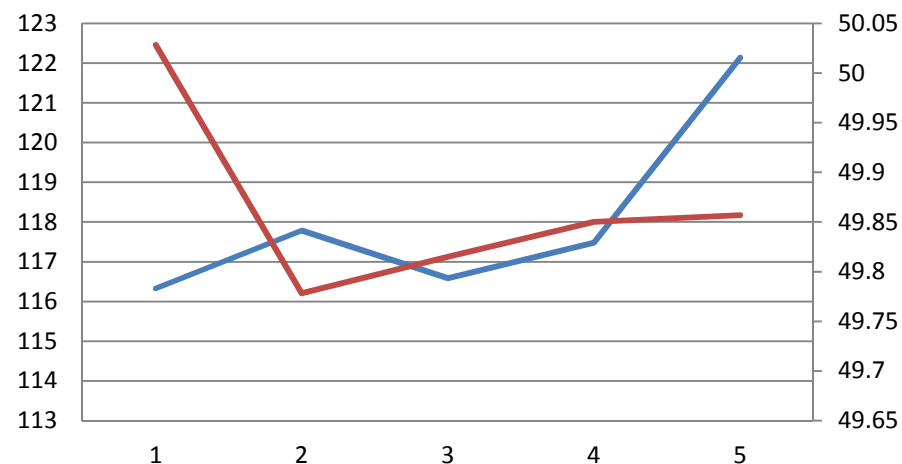

### BTPS Unit 3

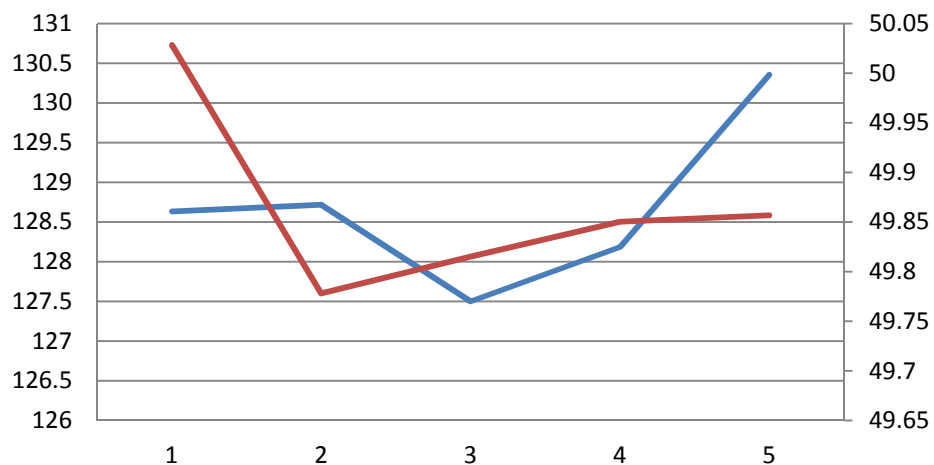

1- 10:35; 2- 10:36; 3- 10:37; 4- 10:38; 5- 10:39



Freq



MW

# KOPILI

\*Data as per SCADA data

### KOPILI Unit 1

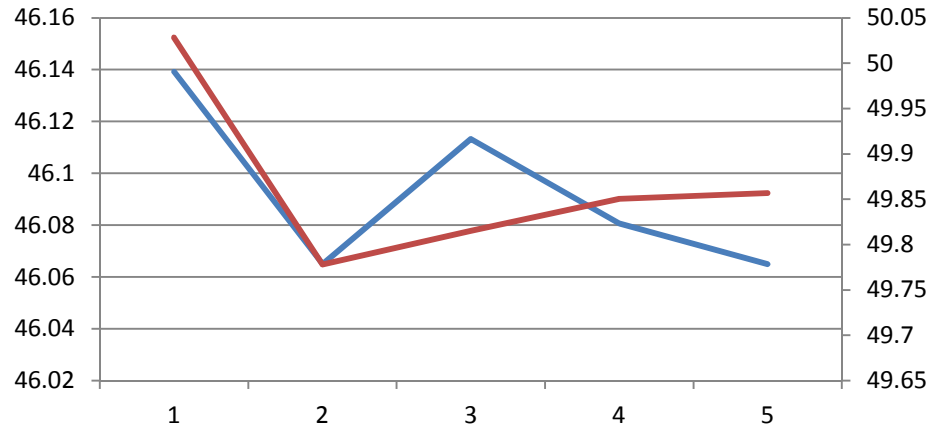

### KOPILI Unit 2

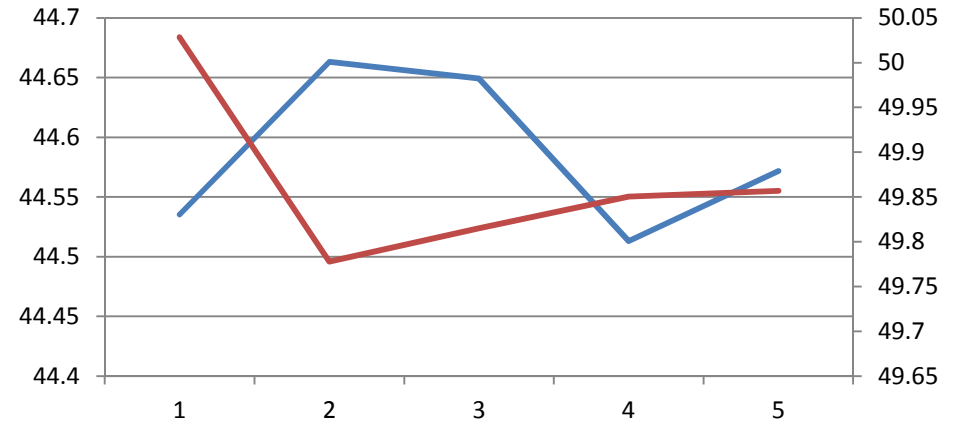

### KOPILI Unit 3

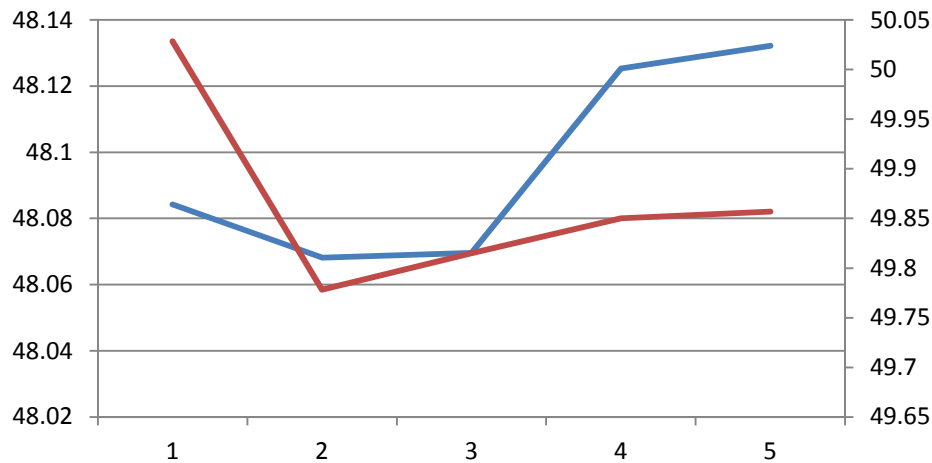

### KOPILI Unit 4

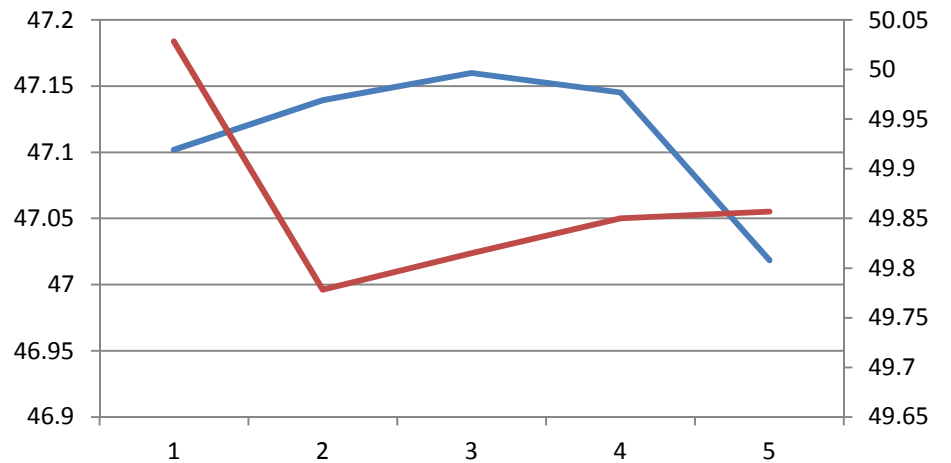

1- 10:35; 2- 10:36; 3- 10:37; 4- 10:38; 5- 10:39

— Freq — MW

# KHANDONG

\*Data as per SCADA data

## KHANDONG Unit 1

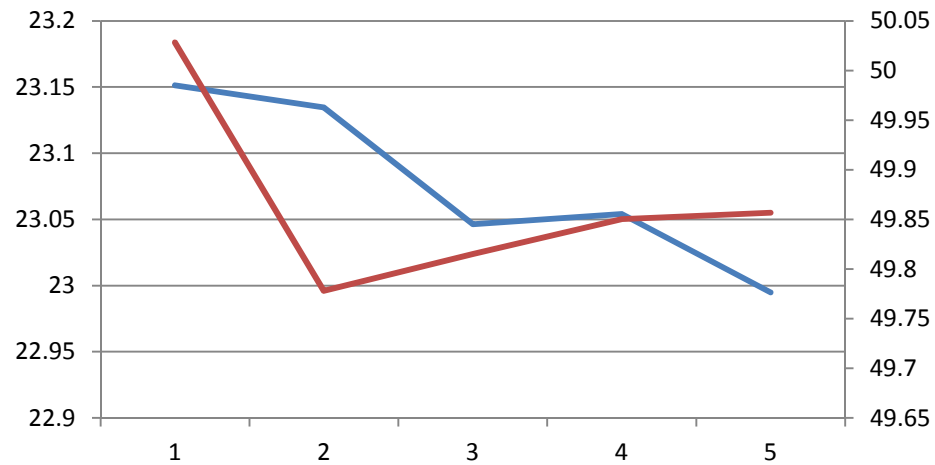

## KHANDONG Unit 2

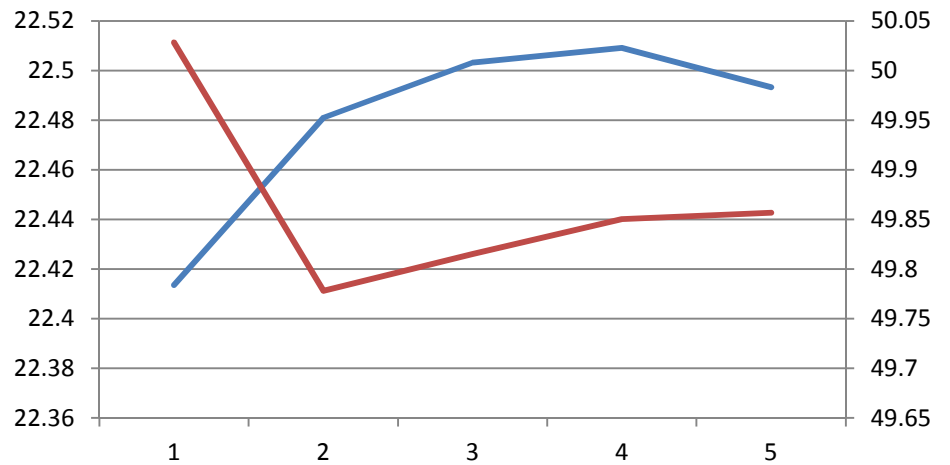

## KHANDONG Unit 3

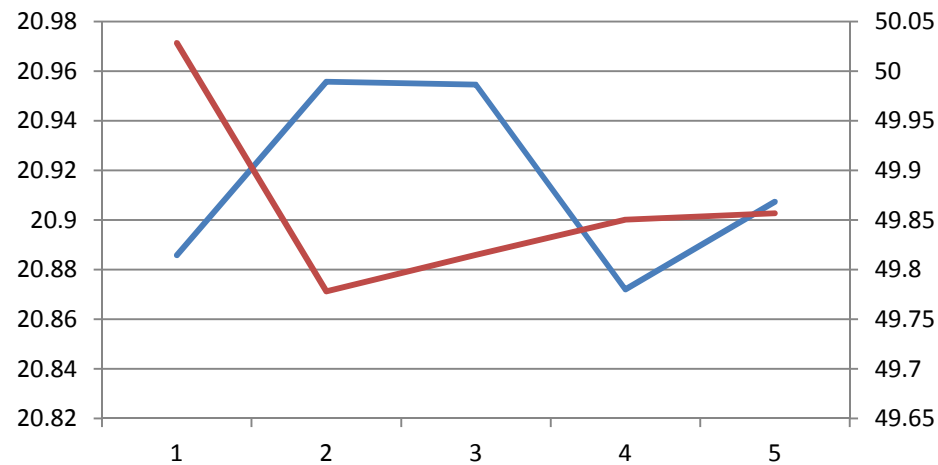

1- 10:35; 2- 10:36; 3- 10:37; 4- 10:38; 5- 10:39

— Freq — MW

# PARE & RANGANADI

\*Data as per SCADA data

## PARE Unit 1

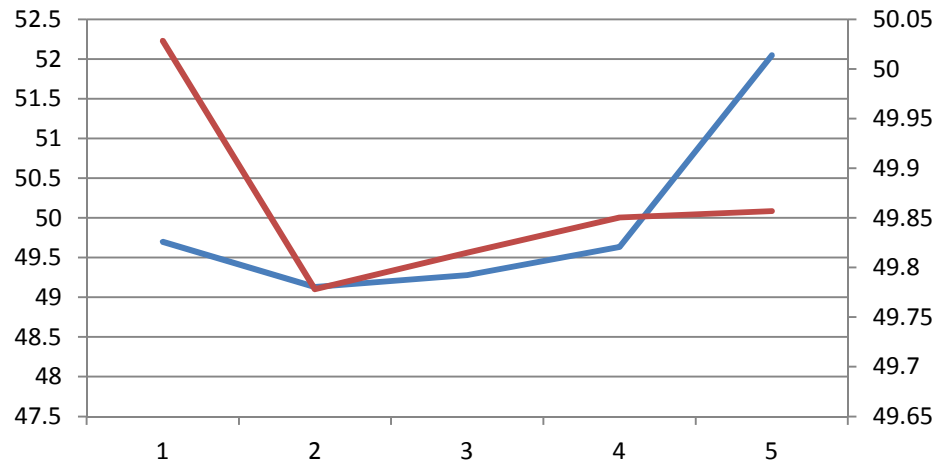

## RHEP Unit 3

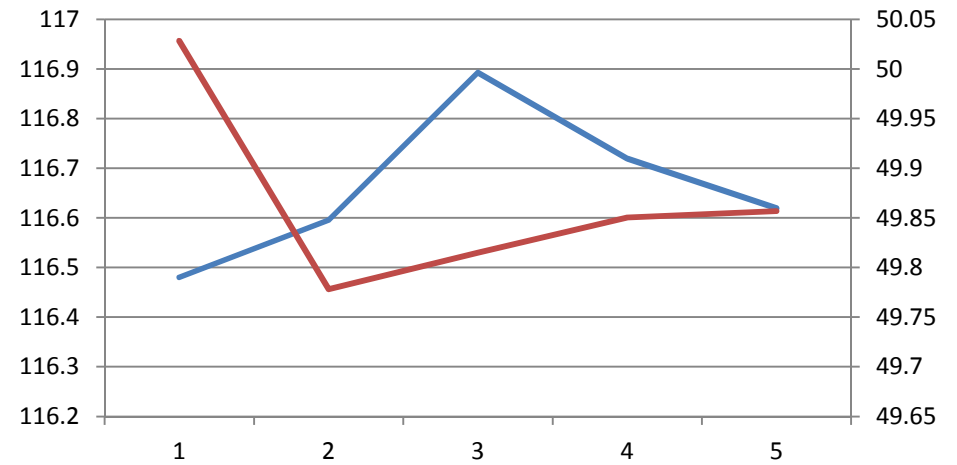

1- 10:35; 2- 10:36; 3- 10:37; 4- 10:38; 5- 10:39

— Freq — MW

# Actual Vs Ideal Response

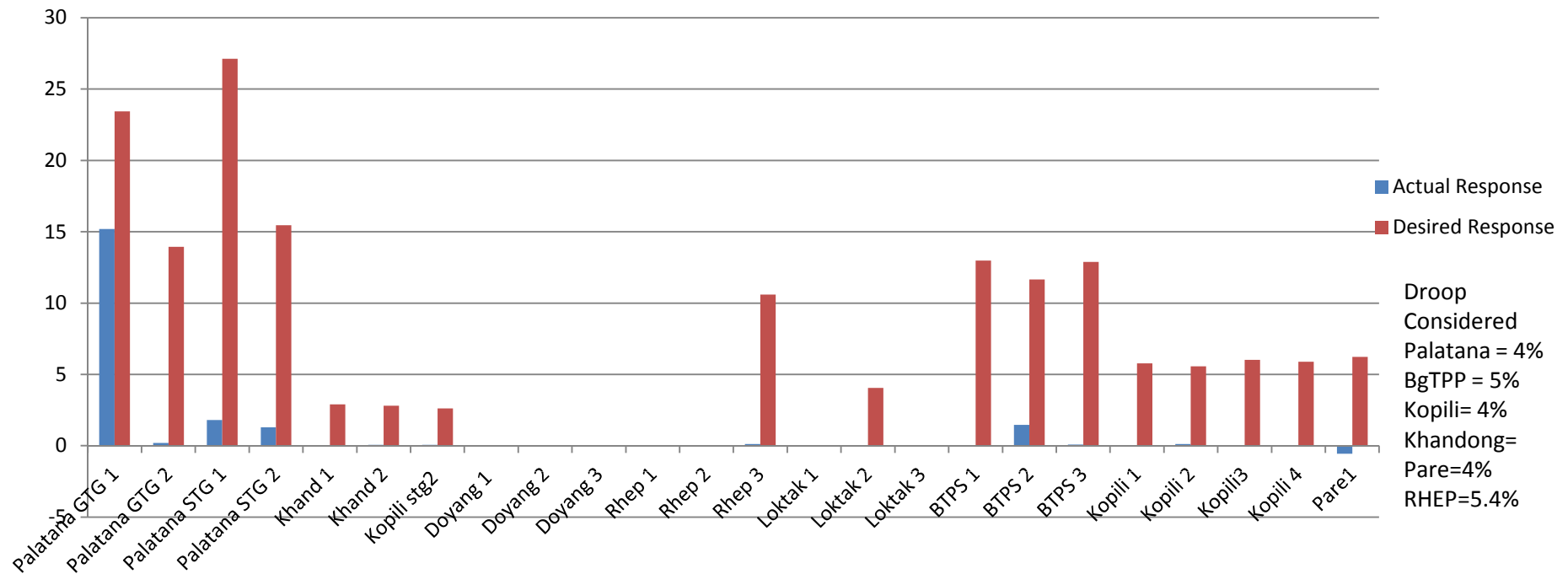

- Observations:
  1. All generating units have given positive response (except Khandong Unit 1, Kopili unit 1 & 3 and Pare Unit 1) but response less than the desired response

NERLDC



*THANK YOU !*

# GE Grid Solutions

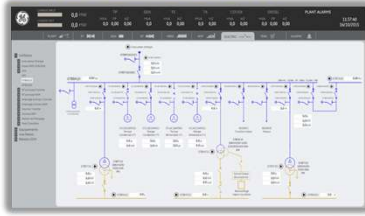

## Advanced Automation Applications Platform

To address the Digital Transformation of Electricity and their challenges GE offers his know-how and experience creating a dedicated area called Advanced Automation Applications (AAA). Within this area GE provide solutions to afford new applications demanded by customers, Automatic control of the Grid and fast decision makers using the standards IEC61850, C37.118 and providing architectures, functionalities and algorithms to satisfy the customer needs.

The goal of GE's Advanced Automation Applications (AAA) area is to strengthen the power systems inside and outside of the substations making Power systems and critical electricity usage safer, more resilient & smarter.

This transforming grid needs innovative technical solutions that can help address these challenges. As a trusted partner, utilities and industrial customers globally are working with GE to implement solutions that deliver power system reliability, security, efficiency, and cost controls needed to operate a modern grid covering but not limited the following areas:

**GPG** series is an embedded Application Ready Platform (ARP) that can shorten development time and offers rich networking interfaces to fulfill extensive needs. GPG series is designed to be a total solution for network enabled Application Ready Platforms. Leveraging field-approved and worldwide approved real-time OS technology, GPG series provides a Windows Embedded ready solution and a RTOS VxWorks 7 with hypervisor Technology, and supports several standard networking interfaces, such as Ethernet, RS-232/422/485 and more. Because of its openness, great expansion capability and reliable design (fan less and diskless), the GPG series are ideal embedded platforms for implementing the core drivers of Advanced Automation Applications.

**GENESIS** is the Licensed software platform running in the GPG.

## Key Benefits

- Simple, cost effective and technically complete solution for Advanced Automation Applications including Monitoring & Control for Utilities and Industrial, Microgrid, Wide Area Management Systems, SIPS (Special Integrated Protection schemes).
- **Advanced Applications Engine** using a RTOS with hypervisor and the latest hardware profile expandable and open to new requirements.
- **Scalable:** Monitoring and control of small systems i.e. 1 bay, up to huge industrial applications and very complex automatic functions.
- **Flexible:** Quick response and adaptation to customer requests. Very customer oriented and focused.
- **User Friendly:** easy to learn, easy to use (less than 2 week when developing a full monitoring system with 50 devices), connecting devices quick and easy, creating project screens with very little effort.
- **Optimized:** Solution designed and specified by Substation Automation Engineers.
- **Well proven:** Multiple IEDs coverage, Expertise on Whole Eng Solutions, Long term Relationships with Partners and end Customers, Trustable Advisor, Stable product since 1996.
- **Cloud Connectivity**



## Applications

- **Advanced Automation Applications (AAA).** To strengthen the power systems inside and outside of the substations making Power systems and critical electricity usage safer, more resilient & smarter. Across the Utilities, Across the Industry, Across Microgrid.
- **Gateway.** Collecting data downstream and sending this data upstream by means of a complete suit of protocols.
- **Monitoring & Control.** GENESIS can Monitor and Control more than 1000 devices having the possibility of customizing more than 500 views using the latest visualization features such as zooming, decluttering, panning.
- **Disturbance Recorder / eRMT.** GENESIS automatically retrieves the oscillos, and save as historic the event logs, metering and controls for further analysis.
- **Industrial Systems.** Monitoring and Control of large LV and MV Motor Control Centers and Oil & Gas Plants providing optimal monitoring and control and automation features.
- **Power Generation Monitoring and Automation Systems.** Integration of the Electrical devices of the Power plant into a single System. The ECS is an Electrical Control System dedicated to the electrical world control / monitoring / diagnostic in Power Plants:

## Cibersecurity

- Aligned with IEC62351 standard. Encryption, Authentication, Hardening, Whitelisting, Achilles L1

## Hardware

- IEC61850-3, PRP, HSR, PTP, IRIG-B, expandable
- Windows Embedded and RTOS VxWorks for critical Real Time application where ms of time response is required.



imagination at work

## AAA Product Platform structure

The platform includes the **Software (GENESIS)** and the **Hardware (GE Power Gateway, GPG)**.

### Key Benefits

- ❑ Multilanguage support.
- ❑ **IEC61850 ed.2 compliance.** KEMA certificate
- ❑ Roadmap **aligned with Customer needs.**
- ❑ AAA Platform includes in a **single product** a data concentrator, Advanced Applications Engine, gateway, HMI server, HMI client and data-logger. This ensures full compatibility between its components and reduces the complexity and speed of future developments..
- ❑ HMI Servers are not needed in AAA solutions as GPG acts as data Concentrator, gateway AND HMI Server. This reduces the cost and failure points in the system.
- ❑ GENESIS has been developed to be **clear, simple, and fast to configure** with a single Configurator tool to configure not only the communication with IED, PLC and control centres but also all HMI screens, reducing the speed, cost (man power) and complexity to build a system.
- ❑ Configuration of **communication between data Concentrator and HMI** clients is **automatically done** in the AAA platform reducing possible errors and configuration time.
- ❑ GENESIS can run in any windows based operating systems which gives the possibility to run it in GPG, an industrial server, a standard PC etc. This makes it flexible to adapt it to a wider number of applications and customer demands as there will not be any hardware limitations.
- ❑ Number of devices that the AAA platform can handle is higher than **1000 downstream and 6 upstream.**
- ❑ AAA platform has a very powerful IEC 60870-5-104 server. It is KEMA certified, enabling it to use with attending different profiles worldwide.
- ❑ **HMI** uses **vectoral drawings** allowing Zoom and Pan functionality.
- ❑ Multiple screens can be opened at a time in HMI even having the possibility to display an overall overview of all opened screens.
- ❑ It is possible to disable/enable communication to an IED from the HMI client, being this useful during maintenance or testing operations not to send undesired data to control centres and HMI clients.
- ❑ Having **one single and simplified product** that gives the complete solution results in the possibility to quickly train the users to achieve a high level of knowledge, allowing users to configure a complete project and give valuable support to end customers. With GENESIS, one single person can quickly become an expert on all SAS solution levels (data concentrator, HMI, control centre communication, Automation Functions).
- ❑ The Platform architecture is designed to refresh any variable in the database in 1 second maximum. The engine of **the Advanced Automation Applications** when embedded in a RTOS; **VxWorks 7**; offers a cycle time of milliseconds even for complex algorithms.
- ❑ **Web server** for historian and SOE
- ❑ **Cloud connectivity** built-in.

## AAA Product Platform structure

The platform includes the **Software (GENESIS)** and the **Gateway (GE Power gateway, GPG)**.

### GENESIS. Software Platform.



**CONFIGURATOR**  
Tool to build the DataBase

CONFIGURATOR is the configuration tool used for :

- Programming HMI screens
- Configuring communication to IEDs downstream
- Configuring communication upstream to Level 3 (DCS and NCCs)

The system configuration will be saved in a database..



**VIEWER**  
Graphical Visualization and Data Analysis Tools

**VIEWER** is the online software that provides the Graphic User Interface for control and monitoring of substation systems. Viewer runs on a Station Level Computer.

The system screen will include a series of screens where all the substation components can be represented. Navigation between the different screens is made with a single click.



**CONCENTRATOR**  
Communication drivers and Database Engine

**CONCENTRATOR** is the communication driver that gathers information from all the IEDs and also distributes this information to the different applications including Level 3 clients and GE Power HMI. It runs on a dedicated Station Gateway device; GPG.

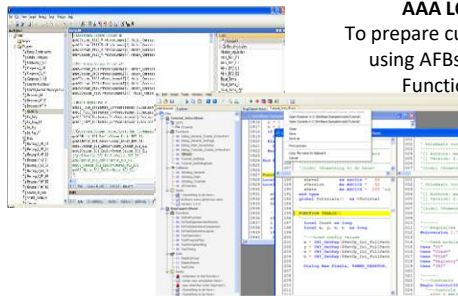

**AAA LOGIC BOX**  
To prepare customized Logics using AFBs (Automation Function Blocks)

Last generation of PLC with a full set of programming tools to develop complex substation level logics, examples:

- Capacitor Bank control
- Substation Reconfiguration
- Load Shedding
- Interlocks & Complex logics

Directly integrated in the Communication Driver  
IEC61850 GOOSE / PMUs capability for direct logic schemes  
Seamless Third party relay integration in the logics

## Configurator

### Project Structure

The organization of the Project database is ordered in a Folder Structure.

All the project files (database, icd files, HMI images...) are gathered under an individual folder which will contain all the necessary information to modify, update or run a system.

### Tree Structure

The tree Structure allows to organize the different devices that conform the substation in groups according to their location in the system and the communication protocol that will be used to communicate with GENESIS.

This design provides the user a whole vision of the system in just one look, simplifying the configuration of the database and reducing the engineering time.

The navigation between the different devices is user friendly and intuitive as all the devices and communication levels will be displayed under the same structure.

### Template Feature

The exporting and importing xml tool contributes to reduce the configuration time. Once one device has been completely configured, an xml file can be created in order to use it as a template for other IEDs.

### IED Menu

The IED menu gathers all the information related to one device under one window. The information has been organized in different tabs that facilitate the user the localization of the different variables and settings of the IEDs.

### 61850 Edition 2

GENESIS has been developed following the Second Edition of the IEC 61850 Standard.

### Vectoral Graphics

Vectoral Graphics (.png, .svg) can be used to represent all the objects on the different screens, increasing the resolution up to 1600x1200 pixels.

### Zooming and Panning

The zooming and panning feature can be used during the configuration steps in order to show the user the final view of the HMI. The objects can be configured to be displayed at different zoom levels. This can be simulated by activating the decluttering option in the tools menu.

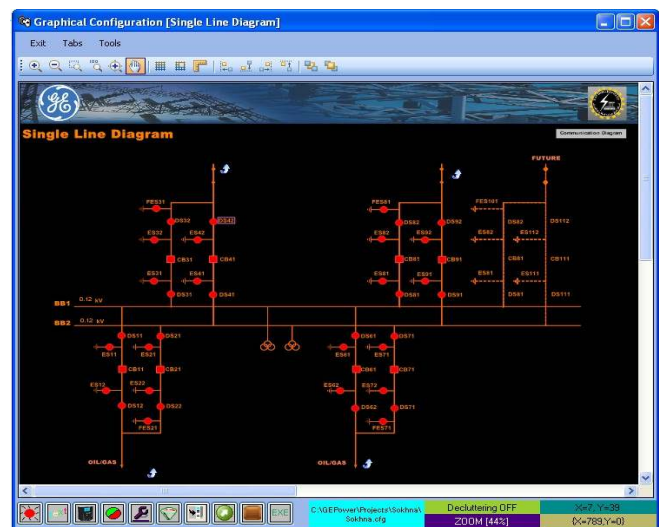
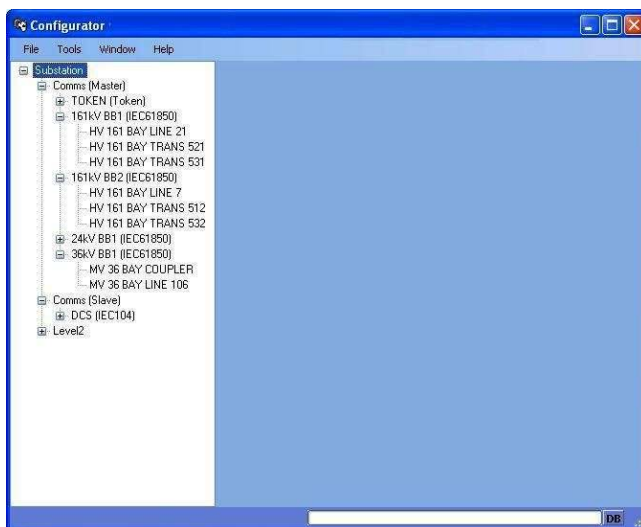

## Viewer

### Multi-Window

The HMI screens can be displayed under tab or window format.

The window mode, that can be chosen between cascade, horizontal or vertical, allows to have more than one screen open at the same time.

This feature joined with the GOTO object allows the user to jump from one screen to another with just one click, simplifying the navigation.

If the tab structure is selected, there will be a preconfigured tab window that will display all the active tabs.

### Zooming and Panning

The operator can see the hole status of the substation with just one look . The graphical objects represented on the screen can be related to the zoom level which allows to have more objects displayed on the HMI when zoom in.

### Interlocking Representation

A new interlocking displaying format have been developed. The graphical representation of the interlock is done automatically and the status are refreshed in real time

### Trending Object

Higher resolution, complete range of graphical objects, higher accuracy.

The trending object allows the user to analyze online measures that are being retrieved from the system. It permits to combine different measures in the same graphic and to freeze the capturing.

The values of the measures can be exported directly from the trending object to an excel file, HTML Table, Text or XML format. The graphics can also be exported as bitmaps.

### Alarm Panel & Alarms Management

Alarm panel with filtering, grouping, freezing and sorting option. These options help the user during the maintenance and testing operations, makes easier to identify and follow sequentially the alarms related to one event.

The alarm filtering can be applied for an IED, for a group of IEDs, by priority or by time. Different logic operators can be applied to the time filtering:

- Equal to a time stamp
- Greater or Less than
- By time periods

The color representation of the alarms in the Panel will depend on their status and they will automatically update once they have been deactivated or acknowledged.

The alarms can be acknowledged one by one, IED-wise or all at a time.

The screenshot displays the HMI interface with three main windows:

- Single Line Diagram:** Shows a GE logo and a diagram of a substation with various components like busbars and breakers.
- Filters:** A panel for filtering IEDs and Groups. It lists IEDs such as NIVEL2, EI Tebbin D25, EI Tebbin D90 Plus, EI Tebbin D60, EI Tebbin C60, EI Tebbin BFR, EI Tebbin F60, Abu Zaabal D90 Plus, Abu Zaabal F60, Abu Zaabal C60 AR, and Abu Zaabal D60. It also lists Teams and Groups.
- Alarms:** A table showing a list of alarms with columns for IED, Date, Time, Alarm, State, Acknowledged, and Group.

IED	Date	Time	Alarm	State	Acknowledged	Group	
0	EI Tebbin D25	2012/03/27	11:07:14.096	A.C.LOSS OFCIRCUIT1 M.C.B. ON	On	<input type="checkbox"/>	Group
1	EI Tebbin D25	2012/03/27	11:10:28.301	D.C.LOSS OFCIRCUIT1 M.C.B. OFF	Off	<input type="checkbox"/>	Group
2	NIVEL2	2012/03/27	11:06:47.757	Master ON	On	<input checked="" type="checkbox"/>	GROUP
3	NIVEL2	2012/03/27	11:06:47.757	Comms L3 OK	On	<input checked="" type="checkbox"/>	GROUP
4	NIVEL2	2012/03/27	11:06:47.757	Comms L1 OK	On	<input checked="" type="checkbox"/>	GROUP
5	NIVEL2	2012/03/27	11:06:47.800	Alarms ON	On	<input checked="" type="checkbox"/>	GROUP

## Concentrator

The Engine of the Gateway platform.

Concentrator is the communication driver of GENESIS system. It creates communication links between the system and the process devices downstream, like IEDs, RTUs, PLCs, etc, using different protocols. Each protocol has its own characteristics and physical media so interfaces have to be built accordingly.

Concentrator offers the possibility to connect to a remote SCADA or DCS in the plant or to a Dispatch Center using any of the protocols available. Concentrator can be configured to act as a communication gateway, routing the information downstream to upstream.

Concentrator includes an online simulation from which the engineer can force any point in data base validating the functionality of the system and validating the upstream communication links upstream.



## AAA Logic Box

The engine of GENESIS platform when embedded in GPG Gateway to develop Advance Automation Applications is the logic box compliant with the standard IEC61131-3.

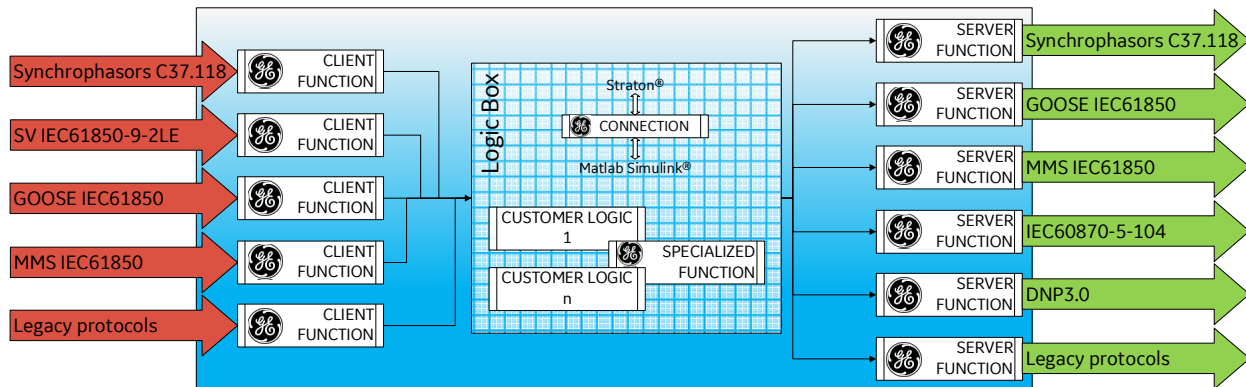

- The **Client Functions** allow data from different protocols to be treated in Logic Box with all the information/fields contained in it.
- The **Logic Box**, through Matlab Simulink and a very Powerful SoftPLC, interconnected, enables to do a tailor-made logic (customer logic) for each different AAA applications.
- Server/ Client functionality enables the communications Peer to Peer, to other Clients or to Dispatch center
- Logic Box** Enables to utilize the technical background from GE in Advanced Automation Applications and enables customer to develop their own logics.

The Logic Box supports all the five languages of IEC61131-3;

- Sequential Function Chart (SFC)
- Function Block Diagram (FBD)
- Continuous Function Chart (CFC)
- Ladder Diagram (LD)
- Structured text (ST)
- Instruction List (IL)

The Logic Box provides very powerful tools for online debugging and simulating the IEC 61131-3 application. The Log window displays all run time messages sent by the target or by the simulator when testing the application. The Spy Lists is a powerful monitoring tool that enables you to spy variables of the application at run time and build list of variables that you can save and re-open. Variables of simple data type could be spied as well as arrays, data structures and statements. It also includes a complete set of Debugging tools allowing but not limited to:

- Diagnostic information
- Step by Step debugging
- Digital Sample trace
- Soft scope

The Logic Box contains a IEC61850 SCL editor defined by the IEC61850-6 standard integrated in the PLC editor.

## Gateway. GPG



GE Power Gateway (GPG) series is an embedded Application Ready Platform (ARP) that can shorten development time and offers rich networking interfaces to fulfill extensive needs. GPG series is designed to be a total solution for network enabled Application Ready Platforms.

Leveraging field-approved and worldwide approved real-time OS technology, GPG series provides a Windows Embedded ready solution and a RTOS VxWorks 7 with hypervisor Technology, and supports several standard networking interfaces, such as Ethernet, RS-232/422/485 and more. Because of its openness, great expansion capability and reliable design (fan less and diskless), the GPG series are ideal embedded platforms for implementing the core drivers of Advanced Automation Applications.

### Target on Data Server and Communication Gateway in Substations

GPG series has been defined and designed to be compliant with IEC-61850-3, which has been defined as an international hardware standard of communication network and system in power substations.

### 2x Expansion Slots for Substation IO

GPG series offer 2 expansion slots for modularized IO plug-in card. With these expansion slots, GPG series can optional equips isolated serial ports, IRIG-B, as well as fiber optical Ethernet interface.

Some applications need to install 2nd SSD. GPG series can also optional provide the SSD kit to install a redundant SSD in the expansion slot.

### Robust IO Isolate System from Electrical Noise

GPG series is designed for the applications in substation where is supposed to have certain electric interference. Equipping with isolated power and isolated communication ports, GPG series has high resistance toward electrical noise. It has been proved not only can work well in substation but also suitable for any harsh applications

### An Industry-Proven Design

Industrial applications require controllers with high-vibration specifications and a wide temperature range. Controllers in industrial environments require flexible and stable mounting, and many machine builders underestimate the need for rugged controllers because their applications are mounted in an industrial enclosure. GPG has a special design without the weaknesses of a standard PC. No fan, and no HDD prevent dust and vibration problems. With a smart mechanical design, GPG series can meet 50 G shock (with CompactFlash), 2 G vibration (with SSD), up to 70° C operating temperature (tested under 100% CPU loading) and almost anything an industrial environments demand.

### Designed to Fit Comfortably Into Racks

In completely new packaging, GPG series has standard 2U rack size as 440 x 280 x 88 mm (W x H x D) could fit your rack. The rear IO connection and indicator LEDs on the front panel for all ports and modes highly simplify monitoring for operation and maintenance in the rack. You could easily mount GPG series on rack.

## Hardware Specifications

### General

Certification: IEC 61850-3, IEEE 1613, CE, FCC Class A, UL, CCC  
 Dimensions (W x D x H): 2U (440 x 280 x 88) mm (17.3" x 11" x 3.4") fits into standard 19 inch rack  
 Enclosure: SECC & Aluminium  
 Mounting: 2U Rack mount  
 Power Consumption: 19W/220VAC or VDC (Typical)  
 Power Requirements:  
 AC: 100 ~ 240 VAC (47 ~ 63 Hz) DC: 100 ~ 240 VDC  
 DC: 48VDC with isolation protection, AT  
 Weight: 6.0 kg  
 System Design: Fan less with no internal cabling  
 OS Support: Windows Embedded and RTOS VxWorks for critical real time applications such as Fast load shedding logics.

### System Hardware

CPU: 2 options: Intel Haswell Core i7 1.7 GHz (used for high demanded Advance automation applications; Microgrid, WAMS) / Intel haswell 2980U 1.6 GHz  
 Memory: i7 series 16Gb RAM / Haswell Series 8Gb RAM  
 Indicators: LEDs for Power, IDE, Programmable LED, LAN (Active, Status), power-fail indication and Serial (Tx, Rx)  
 Keyboard/Mouse: 2 x PS/2 connector for Keyboard & Mouse  
 Storage:  
 SSD - Built-in one SSD 128Gb. Extended temperature. Write protection system. Designed for industrial environments.  
 Display: DB15 VGA connector, 1600x1200 @ 85 Hz. 1 x DVI-D, 1920 x 1200 @ 60 HZ

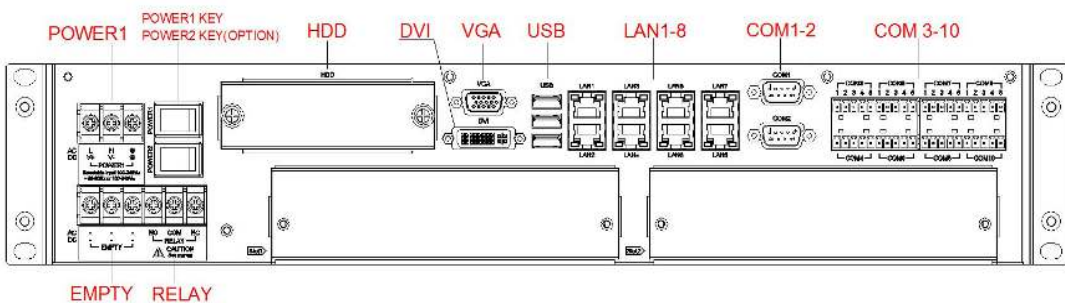
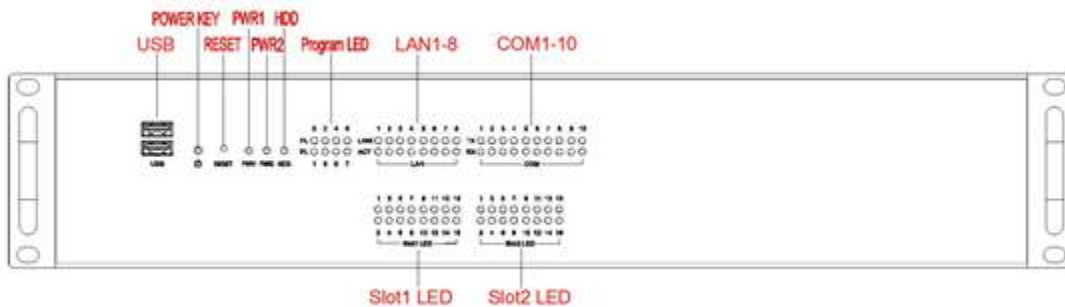

## Ordering Codes

POSITION	GPG	-	X	--	--	XX	--	-	DESCRIPTION
									8x 10/100/1000Mbps 10BaseT RJ45 + 2x DB9 RS232 serial ports + 5x USB
4		S							Standard Applications
		E							Reserved **
6,7 (SLOT 1) 8,9 (SLOT 2)				XX	XX				None
				IB	IB				IRIG-B + 4x Isolated RS232/422/485 serial ports
				RS	RS				8x Isolated RS232/42/485 serial ports
				M1	M1				2x SFP 10/100Mbps RJ45 + 2x PRP/HSR SFP 10/100Mbps RJ45
				M2	M2				2x SFP 100Mbps LC FO Multimode + 2x PRP/HSR SFP 100Mbps LC FO Multimode
				G1	G1				2x SFP 10/100/1000Mbps RJ45 + 2x PRP/HSR SFP 10/100/1000Mbps RJ45
				G2	G2				2x SFP 1Gbps LC FO Multimode + 2x PRP/HSR SFP 1Gbps LC FO Multimode
12,13							HI		Redundant AC: 100~240 VAC (47~63 Hz) DC: 106~250 VDC
							LO		Redundant DC: 38 ~ 58 VDC *
14								X	Without Cyber-Security capabilities
								C	With Cyber-Security capabilities (ECCN code 5D002c.1) *

\* Delivery time could be affected. Please refer to your GE sales contact for further details.

\*\* For GE internal use.

### GEGridSolutions.com

IEC is a registered trademark of Commission Electrotechnique Internationale. IEEE is a registered trademark of the Institute of Electrical Electronics Engineers, Inc. Modbus is a registered trademark of Schneider Automation. NERC is a registered trademark of North American Electric Reliability Council. NIST is a registered trademark of the National Institute of Standards and Technology.

GE, the GE monogram, Multilin, FlexLogic, EnerVista and CyberSentry are trademarks of General Electric Company.

GE reserves the right to make changes to specifications of products described at any time without notice and without obligation to notify any person of such changes.

Copyright 2018, General Electric Company. All Rights Reserved.

RL-ENED-2018  
01272018



imagination at work

## AAA Platform. Technical Specifications

<b>Gateway / GPG HMI Server (see ordering code)</b>	
OS	Windows 10 IOT (embedded)
RTOS	VxWorks 7 with Hypervisor ( for special applications)
OS write protected	YES
PRP	YES
HSR	YES
IEEE 1588 (PTP)	YES
IRIG-B	YES
Ethernet SFP ports	Up to 8
Ethernet RJ45 Ports	Up to 16
Serial Ports	RS232/RS485 (Up to 26)
<b>Communication Drivers</b>	
IEC61850 Server Ed.1 and 2	YES
IEC61850 Client Ed.1 and 2	YES (KEMA certified)
IEC61850 GOOSE.	YES
C37.118 Synchrophasor Protocol.	YES
IEC60870-5-101/104 Server/Client.	YES (104 Kema certification)
DNP3 Master/Slave	YES
SNMP	YES
NTP client	With redundancy (up 100 servers)
Modbus RTU/TCP Master/Slave.	YES
IEC6070-5-103 Master.	YES
Spabus Master.	YES
OPC DA & AE Server/Client.	YES
OPC UA	YES
Avalanch performance	Tested with 700 events / sec for 48 hours. 7,000 events in less than 2 secs
Programmable logic	Yes. GE Proprietary and Straton integrated with the Comm driver
Simulation mode	Yes
Predix connection embedded	Yes
Redundancy	Hot-Hot; Hot-standby (Zero lost)
Data Retrieval	Events, Metering, oscillos.
<b>Cibersecurity</b>	
Encryption	Between gateway and HMI (TLS1.2)
Authentication	Between Gateway and HMI
User Management	Radius and LDAP / Pwd encrypted (hash HMACSHA256)
Hardening	YES
Whitelisting	YES
FTPS service	YES
Database protected with encrypted pwd	YES
Database Signed and encrypted	YES
Achilles level 1 pass	YES
OS write protected	YES

## AAA Platform. Technical Specifications

HMI Features	
In House Solution	Yes. Complete Suite developed in GE
Scalability	Priced according with number of IEDs Real Applications for 1 IED up to > 1000 (See Table)
Embedded HMI Solution (in GPG gateway)	Yes
External HMI Solution	Yes
Resolution	Multiresolution. Adaptive. FullHD and 4K compatibility
IEDs Monitoring	>1000
Number of points	Unlimited. Tested with >200,000 points
Multi HMI	Tested up to 50
Multiwindow	YES
Popups	YES
SO supported	MS Windows 7, Win 10, Windows Server.
Vectorial Drawings	YES
Zooming	YES
Panning	YES
Decluttering	YES
Number of Screens	Not limit. Tested with +400 Screens
Interlocking	YES
User Management levels	per functionality 10 groups. Unlimited numbers of users Configurable Rights per user 5 Rights individually configured per user (Navigation, Operation, User admin, Program Exit, settings)
Alarm Management	Yes, Active/Acknowledge criteria (colours settings)
Alarm Groups	Unlimited groups
Alarm Priority	10 sound priority groups
Events Filter	Yes unlimited and user configurable
Alarms Filter	Yes unlimited and user configurable
Remote Alarm Notification (SMS)	Yes
Remote Alarm Notification (email)	Through OPC/email server
Off/On service function	Yes
Template screens (For Multiple IEDs)	Yes
Dual Language configuration	Yes
Multilanguage Software	Yes
Analog Trending objects	Yes
Historian (events, measures)	Yes
Historian data export tools	Yes (csv files)
Remote Access	Remote Desktop, Web Access
Refresh time	< 1 sec
Simulation Tool to validate the database	Yes
Busbar Coloring	Yes
Right Click Menu	Yes
Manual Overwrite	yes (not for measures)
Operator Dialog	Yes (when executing commands)

## AAA Platform. Cibersecurity

Security control	Realization example, notes
Authentication	Strong user-to-device and user-to-application authentication (local and remote)
	HMI. User authentication and single sign-on (SSO) either using user-id and password, e.g. by accessing a directory (ISO/IEC 9594 or LDAP plus SSO addition) or using Kerberos
	HMI. Support of two-factor user authentication technologies (e.g. smart token, OTP)
	Device-to-device authentication, e.g. Client-Server-Authentication via X.509 based certificates
Access control	Enforcement of mutual authentication according to IEC/TS 62351-3, -4, -5 and -6 in IEC based communication protocols
	Definition of a logical security perimeter supported through application of firewalls, remote access gateways, etc. (for local and remote access)
	Enforcement of least privilege escalation
	Definition and enforcement of role-based access control (RBAC)
Integrity	Application of IEC/TS 62351-8 RBAC for access controlled engineering and operation
	Password policy, e.g., complexity criteria, aging, etc., e.g. as provided by ISO/IEC 9594
	Network Segmentation (applying Firewalls and DMZ)
	Application of integrity protection options in SCADA and ICS protocols
Confidentiality	Integrity protection of stored data (e.g. disk, tape)
	Application of confidentiality protection options in SCADA and ICS protocols
	Confidentiality protection of stored live data; disk encryption for engineering and control systems
	Confidentiality protection of stored backup data (e.g. disk, tape)
Monitoring and Logging	Application of IEC/TS 62351-3, -4, and -5 confidentiality protection using TLS in IEC based communication protocols
	Access to confidential data following the need to know principle
	Maintenance and monitoring of computer and network security components, e.g. system event log auditing
	or SNMP v3 application to monitor system events
Management	Login/account management on control and engineering systems
	Auditing / logging of all automated / scripted login sessions
	Logging of control application access, including user ID, event time
	User activity on control systems while logged in
Availability and robustness	System hardening according to security measurement plans
	Regular security assessments of components (e.g., vulnerability scans)
	Definition and maintenance of roles to support IEC/TS 62351-8
	Incident response (events and alarming)
protection	Backup and recovery of business and operation relevant information
	Patch management (organizational part)
	Definition of identification and authentication procedures
	Redundancy concepts for IT infrastructure
protection	Firewall concepts (DoS protection)
	Connection limitations (Bandwidth, number of connections, etc.)
	Malware protection software/appliances, white listing
	Backup and restore concepts and procedures
protection	Application of products supporting a secure lifecycle (product selection should obey security requirements covering the complete product lifecycle)
	Protection of business relevant data (e.g. generation data, system status)

## AAA Platform. Redundancy

GENESIS covers different types of redundancy being aligned with the customer needs. Apart of supporting PRP and HSR allowing the use in such kind of communications architectures, GPG also work in 2 ways:

- ❑ Hot-Standby. Being one the Master and the other the slave. Link through which the token is passed can be also redundant. Master collects the data downstream and sends data upstream. The switching over time can be 250 ms.
- ❑ Hot-Hot. In this case both GPGs work in parallel collecting data from devices downstream and sending data upstream.

In HMI, GENESIS supports to connect up to 50 HMIs collecting data from GPG. When using redundancy in GPGs, the HMI when running in a separate computer detects automatically the GPG Master.

GENESIS allows also to configure more than one IP address to communicate downstream with the devices that support multiple IP address or when customer uses redundancy in IEDs downstream. In this case the communication driver of GENESIS running in GPG will establish the communication through the first IP address and in case of not receiving data driver will switch to the second IP address.

When communication upstream GENESIS provides also redundancy communication through different interfaces.

With all the above and with the robustness of the hardware platform, GENESIS achieves availability ratios of 99,99%

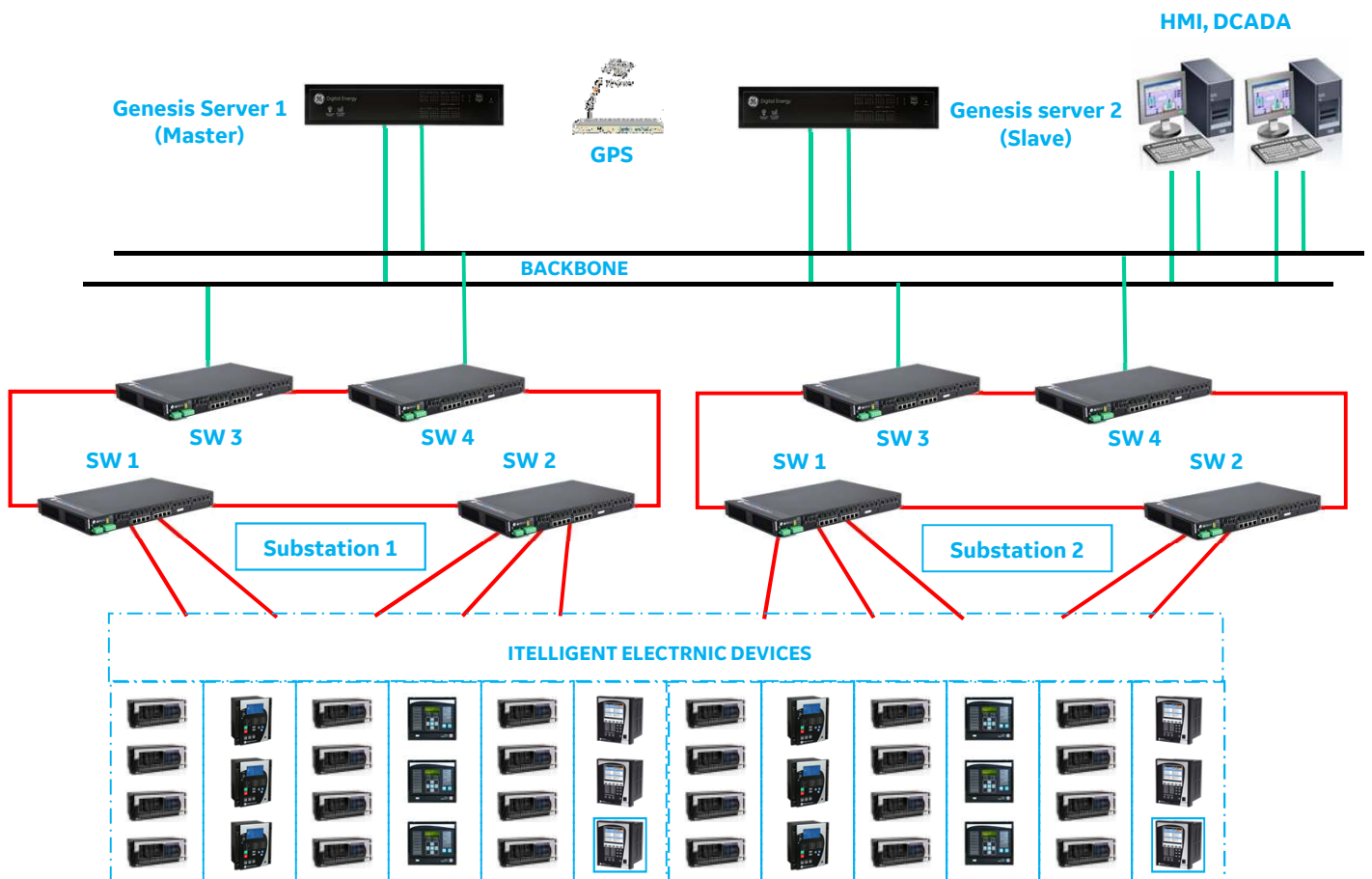

## Applications

GENESIS is a licensed and modular solution with a set of functionalities, which they can be used aligned with customer needs. This allows customer to have in one box a set of functionalities open and expandable.

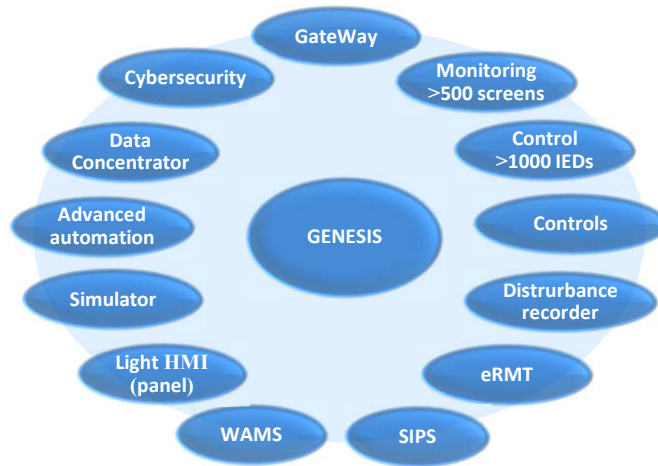

## Micro-System.

One of the key features of GENESIS software platform is the compatibility with Windows when using non real time applications. This feature allows to use GENESIS in a set of applications where the GPG and Real Time applications are not required. This feature together with the scalability makes GENESIS the perfect application where GENESIS has to be embedded in a third party windows based computer.

One of these applications is to use GENESIS in a touch panel computer built in a panel providing Monitoring and control functionalities at bay level providing an All-in-one monitoring and control system for small applications (<10 IEDs). Even in this applications operator takes the benefit of the GENESIS capabilities as for large systems being the main features:

- Panel Mounted Resistive multitouch screen or standalone workstation for SCADA control.
- Multi-protocol system to interface with IEDs and DCS/PMS.
- Can automatically retrieve Oscillographies of P&C relays as well as generating a complete SoE list and Analog sampling historical data.
- Fully customizable HMI for local monitoring and control.
- Redundant Ethernet and Serial communication ports available.
- 1 ms resolution timestamping with IEC61850 Ed2.

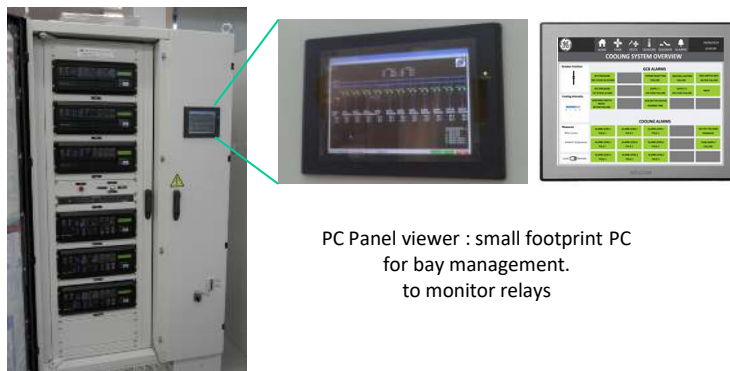

PC Panel viewer : small footprint PC for bay management. to monitor relays

## eRMT

Electrical Remote Monitoring Tool. This application is a Simple centralized Event logging/Disturbance recording aligned with remote monitoring strategies. This ensures SLA response times in events out of customer core skills; Electrical Assets events. This application is a license software running as a Windows service, centralizing events, oscillography and settings modifications running in an on site monitoring HW.

## Monitoring & Control System with Embedded Automation Applications

GENESIS solution supports a vast variety of legacy protocols and it is compliant with IEC61850 standard Edition 1 and 2 enabling GENESIS-based system to collect data from devices downstream and to report data to remote control centers such as National Control Centers (NCC).

Besides GENESIS incorporates a graphical editor to generate a Human-Machine Interface (HMI) empowering operators to fully monitor and control the system.

The configuration of a GENESIS-based system consists of one single database file including the configuration of the Master/Client interfaces downstream, the configuration of the Slave/Server interfaces upstream and the graphical configuration of the HMI. The unique database configuration file of the GENESIS-based system strongly reduces the engineering effort and simplifies the maintenance of the system.

Besides GENESIS includes an IEC 61131-3-based Programmable Logic Controller (PLC) module for maximum data processing and control. GENESIS effortlessly links PLC with the unique database facilitating the system engineering. GENESIS PLC module permits to develop Automation Applications including, but not limited to:

- ❑ **Automatic Transferring of LV disconnectors:** an automatic function controls the supply of the LV auxiliary services board. In case the incomer connected to the LV board is tripped or open, the function automatically closed the alternative incomer to maintain the supply of the LV board.
- ❑ **Sequential Controls:** this function permits to run a pre-defined sequence of controls to open and close a set of disconnectors and/or circuit breakers. The running sequence is continuously monitored. In case any control fails to be executed, the sequence is automatically stopped and an alarm is raised to inform operators.
- ❑ **Power/Voltage/Frequency Load Shedding and Restoration:** this function monitors the voltage and/or frequency and/or Power magnitudes of the power system. In the event of under voltage/frequency condition, the function automatically shed loads to preserve the stability of the power system. Once the voltage/frequency magnitude is recovered, the function starts to restore the loads previously shed following a pre-defined priority sequence. Multiple under voltage and frequency levels can be configured and loads can be prioritized to be load shed and load restored in a pre-defined sequence. Load Shedding and Restoration function can run in one single busbar or it can be expanded to multiple busbars. In case of multiple busbars and depending on the status of the coupler circuit breaker(s) between the busbars, the Load Shedding and Restoration function implements all the possible scenarios, this is, isolated busbars, coupled busbars, etc.
- ❑ **Date/Time Control of Capacitor Bank:** A timer function permits to initiate controls on a pre-defined date/time basis to automatically close or open the circuit breaker of the Capacitor Bank. Operator can define multiple date/time periods when Capacitor Bank is meant to automatically close or open after having confirmed that all the interlocking conditions are fulfilled.
- ❑ **Interaction between automatic functions:** typically, systems running different Automatic Applications (Voltage Load Shedding and Restoration, Frequency Load Shedding and Restoration, Date/Time Control of Capacitor Bank, Automatic Voltage Regulator, Autoreclosing, etc) need to define how the different Automatic Applications interact to each other and which functions have priority over the others. For instance, frequency can be prioritized over voltage for Load Shedding and Restoration functions. If during a voltage load restoration process, the system detects an under frequency condition, the system can immediately canceled the voltage load restoration and start a frequency load shedding and restoration. In the opposite way, if during a frequency load restoration, an under voltage condition is detected, the frequency load restoration can be temporary paused and then resumed after voltage load shedding has been completed. In case of the Date/Time Control of Capacitor Bank and the Automatic Voltage Regulator (AVR), prior to the closing of the Capacitor Bank the system can reduce the voltage reference of the AVR to compensate the voltage increase when the Capacitor Bank closes. When already closed, the system sets back the original voltage reference of the AVR.

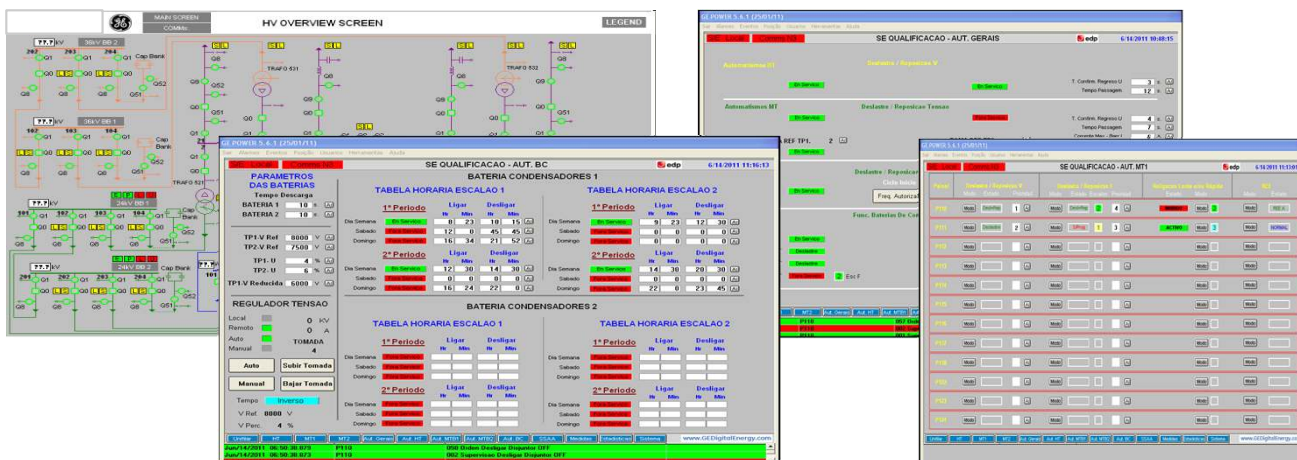

## Industrial Systems.

GENESIS provides a simple, cost effective and technically complete solution for protection and control integration in Motor Control Centers, Oil & Gas Plants and Industrial plants. The system architecture is distributed and scalable and consists of IEDs, a communication network, one or various Human Machine Interfaces (HMIs) and a set of optional remote links to dispatching centers (DCS), maintenance operators, engineering offices...

The architecture and software have been optimized to work in a highly efficient manner with devices downstream, Even though the number of devices for which the GENESIS can be higher than 1000 devices, the refresh time of any point in the database is not higher than 1 second.

When IEDs in a MCC are linked through communications within GENESIS system, the protection and control capabilities are extended to the whole system, as it provides tools that can completely manage any MCC and/or dispatching center. GE's GENESIS system is able to perform associated functions, as well as to retrieve all necessary states, measurements, events and records independently of system integration software. It is scalable, The application is usable for small systems (20 devices downstream or less) and to very large systems with more than 1000 devices.

The system architecture and communication network is designed to be adaptable to every system size, reliability and redundancy level requirements. Thus, there are GENESIS architecture solutions for single/multiple system concentrators, HMI and communication channels at every level.

The operator HMI will include graphical display of MCC one line diagrams and other user configurable screens, equipment status, integrated alarm and event recorders (per IED and MCC level), metering and waveform records as well as access to change of settings and execution of commands.

Several levels of password protection are available to prevent unauthorized access to system monitoring, operation and configuration.

The GPG in this application plays a key role using the multiple serial devices (up to 26) in RS232 and RS485 when required or using the multiple Ethernet interfaces in RJ45 or Fiber optic in multimode and single mode covering and mixing all type of communication architectures.

A connection(s) to a remote dispatching center(s) can be provided. In these applications GENESIS offers as well a large experience with Honeywell, Hyundai and Yokogawa DCS systems when sending the information upstream.

This connection will be established using different protocols; Modbus RTU/TCP, DNP3, IEC101/104, OPC UA.

In general, GENESIS system substitute the following conventional equipment:

- Local and remote mimic panels and related equipment.
- Synchronization equipment panels and related equipment.
- Alarm panels.
- Event recorders.
- Remote data collecting units.

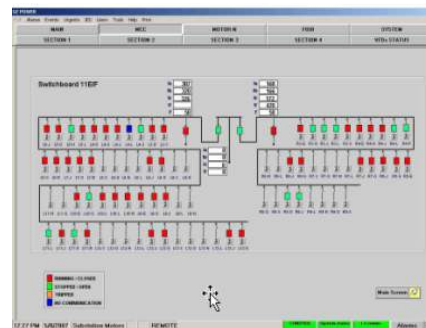
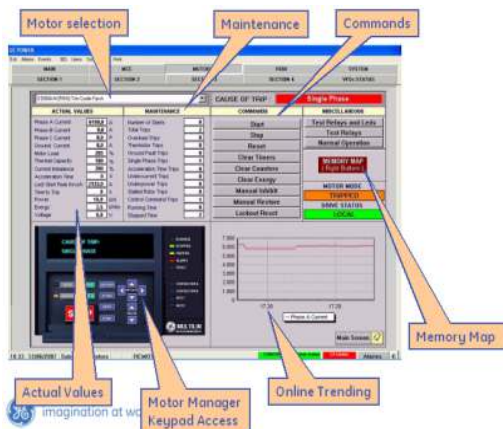

## Power Generation Monitoring and Automation systems. ECS

Today new generation of power plant introduces higher number of smart devices to reduce the site labor by making the maximum of pre-wiring / test at equipment factory and to answer to the Market moving to Digital.

On the process side, most of the instrumentation and valves moved to smart type (e.g. protocol Foundation Fieldbus, Can open...) managed by the Turbine Controller platform.

On the electrical side, most of distribution incomer / feeder breakers as well as MCC starters moved to smart type using Intelligent Electronic Devices (IEDs) with electrical dedicated protocol (e.g. protocol IEC-61850).

New "Digital plant" provides Big-Data for operator remote advance monitoring, predictive signals, remote configuration and is "Predix Ready".

Electrical Control System (ECS) is a GE Grid Automation complete solution of software and distributed logic for automation and monitoring of electrical system. ECS collects, controls & monitors electrical data from IEDs such as the protection and control relays from HV Switchyard to LV motor starter and DC / UPS distribution.

ECS is a multiprotocol platform to adapt to all IEDs providing the flexibility & scalability to integrate multivendor devices and the adaptability to be used regardless of the scope, as it can integrate from 1 to 1000 IEDs.

With ECS, Process and Electrical worlds remain independent while maintaining a high level of integration by using the same Control Room Engineering and Operator Workstation HMI, Alarm management system and Historian. ECS does not interfere with Mark Vie platform process control which remains focused on the plant daily control.

ECS significantly reduces the amount of wiring required for control, supervision and automation functions via the IEDs communicating through various protocols and Electrical Data Highway (EDH) interconnecting all devices together.

The concept of ECS is not new, it is an application of the GE GA Standard Scada used in substation automation since 1999 and expanded the first time to a power plant on the first 9HA GE turbines generation.

ECS system can be implemented to any frame size in three packages from a "Minimal" to a full "Digital" plant.

**Package 1** of the ECS provides advanced control and monitoring of the few smart equipment in a conventional plant such as the Generator and Transformer Protection Panels (GPP / TPP) and HV switchyard in option. Package 1 is fully integrated within Workstation HMIs used by the GT / ST controller.

**Package 2** of the ECS includes Gas Turbine, Steam turbine, and Generator auxiliary distribution with smart MCCs in addition to all the features provided by Package 1.

**Package 3** is the most optimized package that also include the complete Plant BOP auxiliary distribution supplied by GE and Customer / Partner when the BOP and HRSG DCS also use Mark Vie platform.

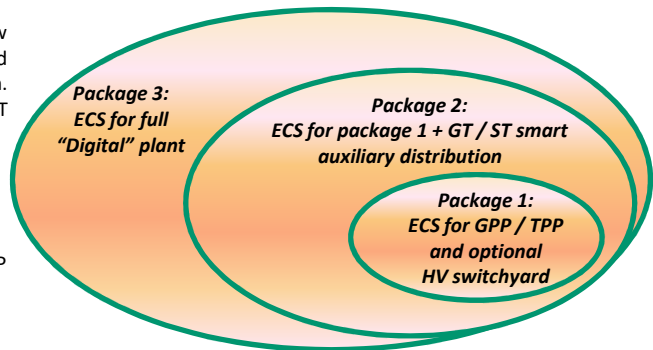

### Level 3: Control Room

- Use Same Engineering / Operator workstations, Gateways, Historian, Alarm management...
- Provide operator interfaces
- Share data to other (NCC, Predix...)

### Level 2: Concentrator:

- Packages data and sends it up to Work stations
- Transmit operator initiated cmd from HMI to IEDs
- Convert data in different protocol

(keeping source time stamping)

### Level 1: IEDs include relevant protection, control, and communicate:

- IED ↔ Mark Vie for motors only
- IED ↔ ECS concentrator for all IEDs
- IED ↔ IED (e.g. ATS)

### Level 0 : Hardwired I/O

- Sensors collect Data from plant (CTs, VTs, position feedback...)
- Actuator provide command to plant (Close / Open command, permissive...)

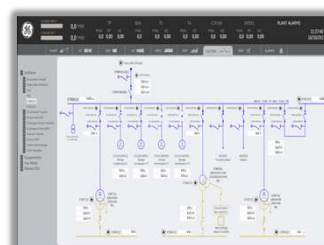
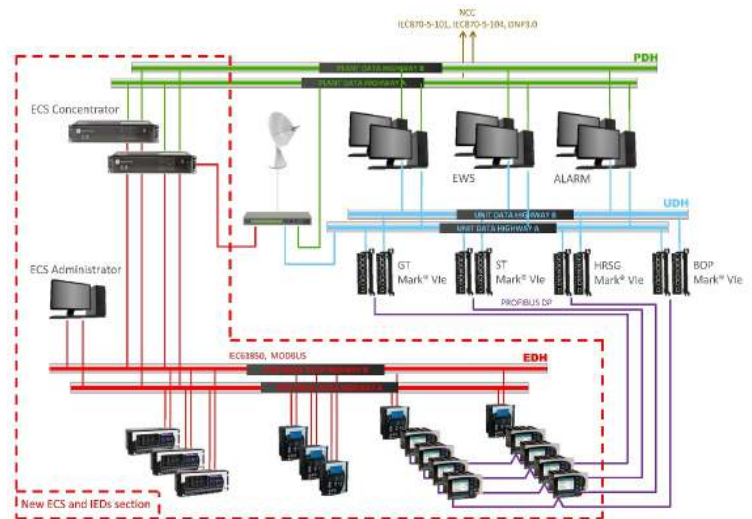

## ADVANCED AUTOMATION APPLICATIONS in Utilities and Industry

The electricity industry is undergoing a significant transformation driven by increasing consumer demands. With the proliferation of renewables and distributed energy resources, the growing use of electronic power elements such as HVDC links and FACTS, new market requirements and a need for more intelligent assets monitoring, customers are facing new complexities and system challenges.

To address these challenges GE Grid Automation offers a set of Advanced Automation Applications (AAA) embedded in the hardware platform GE Power Gateway (GPG).

This transforming grid needs innovative technical solutions that can help address these challenges. As a trusted partner, utilities and industrial customers globally are working with GE to implement solutions that deliver power system reliability, security, efficiency, and cost controls needed to operate the modern grid overcoming challenges.

AAA offers an Engine embedded in the GPG running in VxWorks as RTOS which with the Goose, C37.118 and IEC61850-9-2 stacks, a very powerful PLC engine and an embedded or external HMI with the latest features, make that GPG as a very reliable, fast and deterministic solution to execute these kind of applications. See the Logic Box description.

Logics, algorithms and HMI are fully configurable. Settings can be customized to be sent from HMI as settings to algorithms.

Across the Utilities GENESIS can execute being not limited the following functionalities, including also Wide Area Monitoring & Protection Systems (WAMPS), SIPS.

MONITOR		MANAGE			OPTIMIZE	PREDICT	ADVISE
Diagnose	Awareness	Protection	Control & Grid Stability	Network Operation	Optimal Energy Management	Forecasting	Flexibility & Market
Observability P, Q Monitoring Power Quality Monitoring	HMI user interface Low-Level Data Analytics Discriminate DER Ctrl Access	Protection System Dynamic Protection Groups	Synch (POI Ctrl) Voltage & Frequency Ctrl Coordination Automated Load Shedding Automated RES Ctrl	Local State Estimation Topology Processing Power Flow Black Start	Unit Commitment Optimal Dispatch Thermal Dispatch	PV Short-term Wind-Power Short-term Load Short-term Market Price Short-term	Morphing Multiple POI Support DER insertion, market approach Financial tools Scada Interface

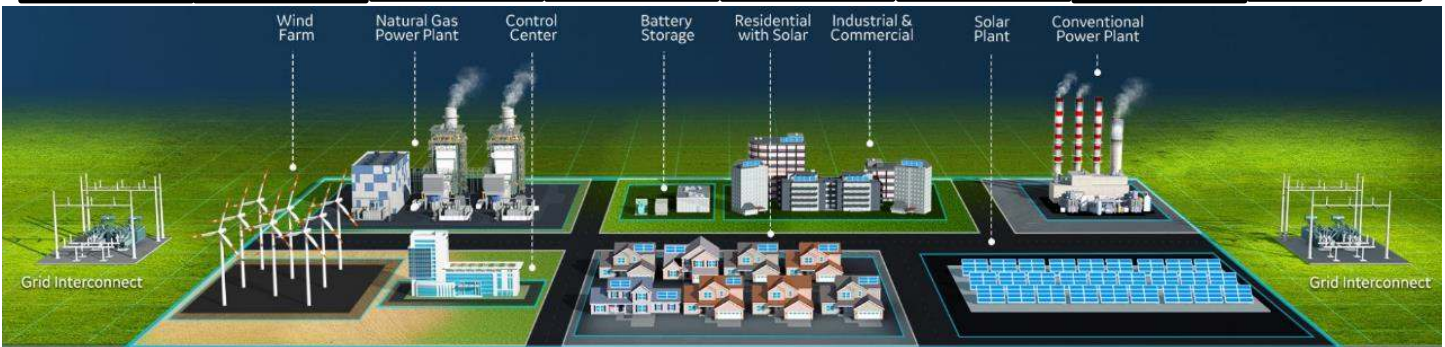

Across the Industry GENESIS can execute being not limited the following functionalities

MONITOR		MANAGE			OPTIMIZE	PREDICT	ADVISE
Diagnostic	Interfacing	Protection	Control & Grid Stability	Network Operation	Optimal Energy Management	Forecasting	Flexibility (Disruptive)
Maintenance Scheduling: load /power management Power Quality Monitoring Local State Estimation Motor Diagnostics	HMI: metering concentration CB monitoring Motor/MCC monitoring Energy Monitoring	Protection System Dynamic Protection Groups Grid point of connection Protection	Synch (POI Ctrl) Voltage & Frequency Ctrl Coordination Automated Load Shedding Automated RES Ctrl	Topology Processing Power Flow Black Start Peak Shaving Self healing and automatic restoration Islanding, Resynch., and Reconnection	Automatic Source Transfer Power Quality control RT Volt/Var Control and Optimization Synch. Automatic Generation Control	PV Short-term Load Short-term Market Price Short-term	Morphing Multiple POI Support Energy Cost Billing Process Interface

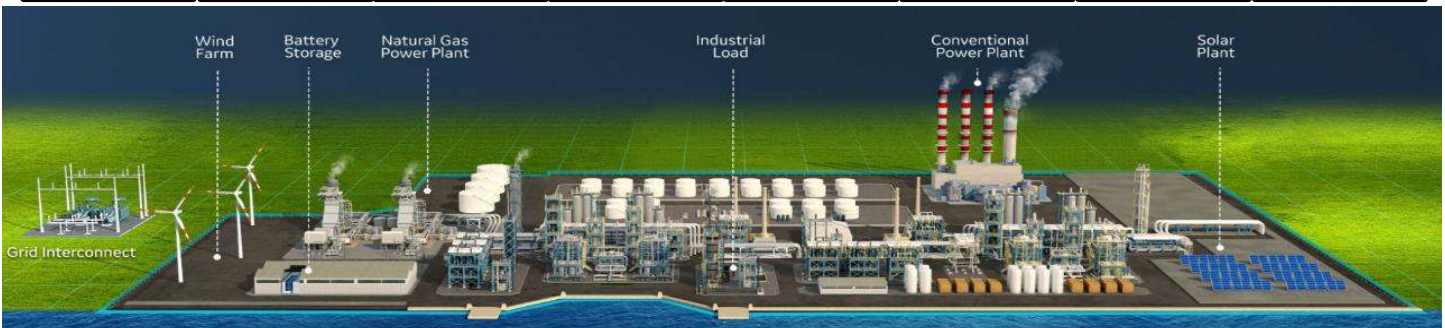

## Advanced Automation Applications in MICROGRID

A Microgrid is an integrated energy system with local Distributed Energy Resources (DERs) such as local loads, generating assets and possibly energy storage devices such as batteries or fuel-cells. A Microgrid system is typically capable of operating in “islanded” (off-the grid) or grid-connected mode.

GPG is suitable for applications acting as a Microgrid Central Controller (MGCC) customizing applications for the maximization of the Microgrid value and the optimization of its operation. It might use simple load forecasts (electric) and forecasts of power production capabilities. The defined optimized operating scenario is achieved by controlling the micro sources existing in the Microgrid by sending control signals through IEC61850 ed.2 to the individual generation units that conform the Microgrid system (Wind Farms, Hydro Power Plants, PV plants and Fossil thermal plants). When using GPG is also possible and advised to include the HMI embedded in the platform . This GENSIS HMI can be customized to configure any possible settable value which will be read by the Algorithms. Also event recording, Alarms sigle line diagram view of the Power system can be also added. GPG when acting as an MGCC can execute Microgrid Applications as described below being able also to include others as showed in the figure.

### Optimal Dispatch

The GPG can include functionalities to provide a supervisory control layer for the Microgrid. The GPG monitors the state of all resources in the system. The dispatch algorithm is processed, and resulting control actions are sent back to each DER. Inputs to the system include the power generated by each DER and the power consumed by each load. Control actions include starting/stopping a DER.

### Volt/Var Control

GPG can include applications for Volt/VAR to compensate the voltage drop caused by reactive power flows over an inductive line. Actions to the generators or inverters could be executed, complemented with control signal to the capacitors or the tap changers, which are able to inject reactive power to the grid.

### Energy Efficiency

All the points mentioned above have as main objective seek for the best energy efficiency in terms of Power management to optimize the power generation and power consumption inside the Microgrid.

As mentioned in point regarding Volt/VAR control, it is possible to increase local distribution network efficiency by optimizing and flattening the voltage profile and by maximizing the reactive power injection into the local distribution network.

### Automation and control

Each generating source and energy storage unit is monitored, and receives commands from the GPG by an IED located locally at DER locations. These IEDs perform the real time measurements of the load or generating units and communicate back to the GPG. These devices also receive the commands from the GPG to control parameters, as active and reactive power, together with voltage, on the dispatchable generators.

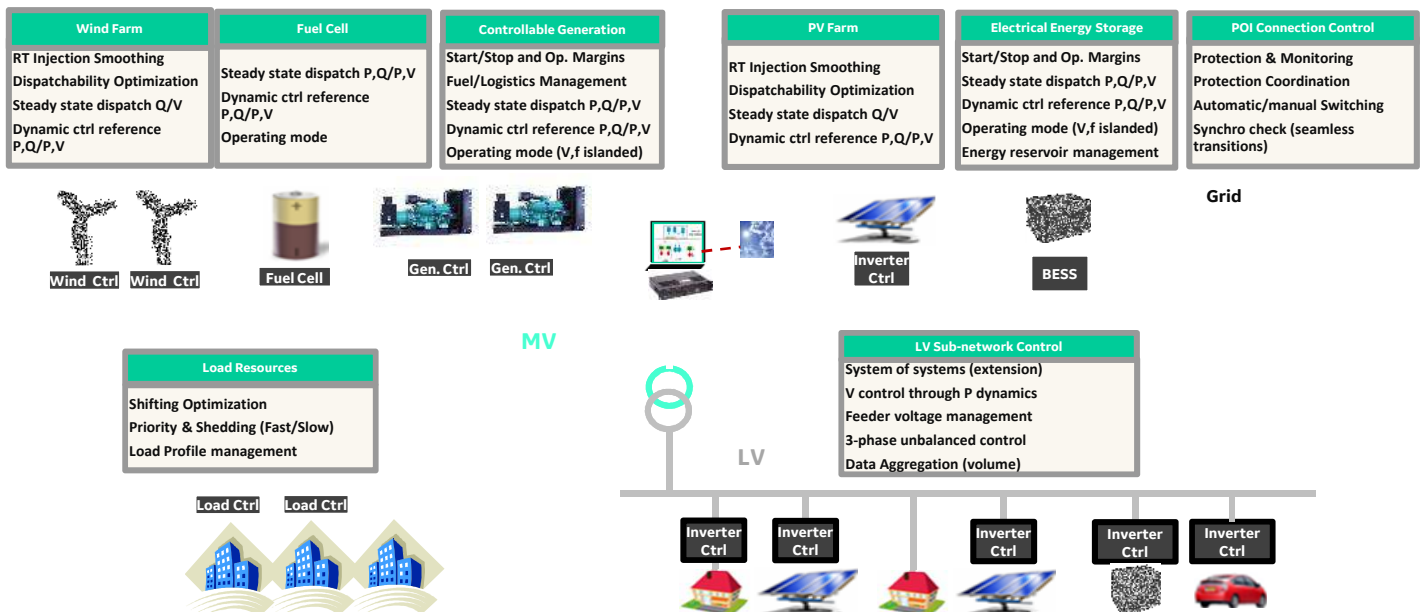

Web Sever. Cloud Connectivity

GPG has a Web Server built-in which allows the customer to monitor the Events, Digitals and Analogs when using GENESIS and GPG with any of the applications mentioned before from any computer or mobile device with a web browser. Also analyses of historic can be done. As an option this Web Server can be allocated in a Cloud such as PREDIX.

Events, Digitals and Analogs are saved in the Cloud allowing the operator to access them from any computer or mobile device using a web browser.

Home **Events** Measures Digitals HMI Files Templates Users

Select DATABASE: Central\_Puerto

Search by IED: Select IED

Search by Name: Search by name

DATABASE	IED	NAME	VALUE	TIMESTAMP	QUALITY	BAF	GROUP
Central_Puerto	G045_11CHA10EW001	86G EX Trip En (V050)	ON	2018-08-24 14:20:05.477000	OK	Bay	Group
Central_Puerto	G045_11CHA10EW001	59G Alm En (V039)	OFF	2018-08-24 14:19:27.196000	OK	Bay	Group
Central_Puerto	G045_11CHA10EW001	59G Alm En (V039)	ON	2018-08-24 14:19:07.366000	OK	Bay	Group
Central_Puerto	G045_11CHA10EW001	87G En (V09)	ON	2018-08-24 14:00:57.142000	OK	Bay	Group
Central_Puerto	G045_11CHA10EW001	Alarm Step En (V067)	ON	2018-08-24 14:00:42.539000	OK	Bay	Group
Central_Puerto	G045_11CHA10EW001	SET_GRP ACT 1	ON	2018-08-24 13:59:11.995000	OK	Bay	Group
Central_Puerto	C078_11BHC10EW001	INCOMER OVERLOAD ALARM	ON	2018-08-24 12:55:09.948000	OK	Bay	Group
Central_Puerto	C078_11BHC10EW001	INCOMER OVERLOAD ALARM	OFF	2018-08-24 12:55:01.839000	OK	Bay	Group
Central_Puerto	C078_11BHC10EW001	INCOMER OVERLOAD ALARM	ON	2018-08-24 12:54:45.848000	OK	Bay	Group

Historic Files and oscillography files can also be stored in the Cloud being available to download for further analysis

Home Events Measures Digitals HMI Files Templates Users

Select IED

MM300	DATABASE	IED	NAME	TIMESTAMP
MM300	MM300	MM300	OSCD13	06/03/18,17:09:13.86100
MM300.1	MM300	MM300	OSCD14	06/03/18,17:18:13.83800
PCCINI IO	MM300	MM300	OSCD15	06/03/18,17:28:13.91900
SMGUMF	MM300	MM300	OSCD16	06/03/18,17:28:13.91900

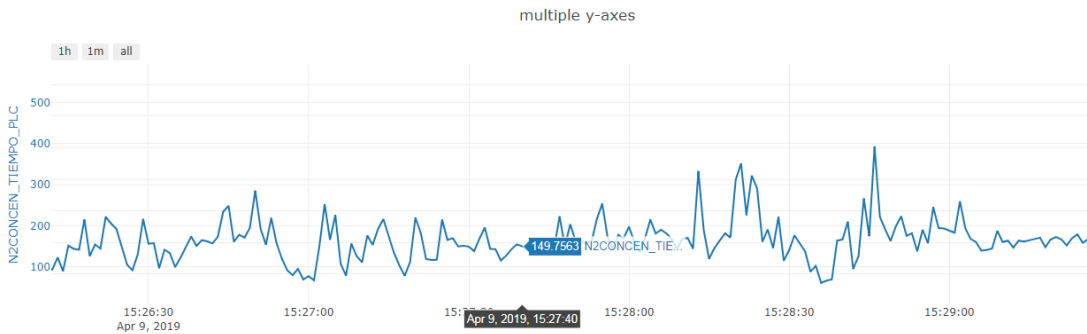

FROM DATE TO DATE

YYYY-MM-DD HH:mm:ss UTC

Cancel Apply

# **Laptop Distribution list**

## **ARUNACHAL PRADESH**

1. KAMENG (NEEPCO)
2. PARE (NEEPCO)
3. NIRJULI (PG)
4. ZIRO (PG)
5. KHUPI (NEEPCO)
6. ITANAGAR (AP)
7. LEKHI (AP)
8. SLDC

## **ASSAM**

1. KATHALGURI (NEEPCO)
2. KOPILI (NEEPCO)
3. KHANDONG (NEEPCO)
4. KOPILI STG-2 (NEEPCO)
5. BADARPUR (PG)
6. BISWANATH CHARIALI (PG)
7. BALIPARA (PG)
8. SALAKATI (PG)
9. HAFLONG (PG)
10. NEW MARIANI (PG)
11. RANGIA (PG)
12. SONABIL (AS)
13. MARIANI (AS)
14. PANCHGRAM (AS)
15. GOHPUR (AS)
16. TINSUKIA (AS)
17. HAILAKHANDI (AS)
18. KAHELIPARA (AS)
19. SARUSAJAI (AS)
20. BTPS (AS)
21. UMRANGSOO (AS)
22. AGIA (AS)
23. SONAPUR (AS)
24. DULLAVCHERRA (AS)
25. PAVOI (AS)
26. BOKAJAN (AS)
27. BACK-UP NERLDC

**FUTURE: TO BE KEPT AT MISA (PG)**

28. SPARE AT MISA 2 NOS

**MANIPUR**

1. IMPHAL (PG)
2. JIRIBAM (PG)
3. NINGTHOUKONG (MN)
4. RENGANG (MN)
5. KARONG (MN)
6. THOUBAL (MN)
7. TIPAIMUKH (MN)
8. SLDC

**FUTURE: TO BE KEPT AT IMPHAL (PG)**

**FUTURE: TO BE KEPT AT IMPHAL (PG)**

**MEGHALAYA**

1. KHLIERIAT (PG)
2. BYRNIHAT (PG)
3. KHLIERIAT (ME)
4. LUMSHNONG (ME)
5. NERLDC 2 NOS
6. SLDC

**MIZORAM**

1. AIZAWL (PG)
2. MELRIAT (PG)
3. KOLASIB (MZ)
4. SLDC

**NAGALAND**

1. DOYANG (NEEPCO)
2. DIMAPUR (PG)
3. DIMAPUR (NG)
4. KOHIMA (NG)
5. KOHIMA (TBCB)
6. SLDC

**FUTURE: TO BE KEPT AT DIMAPUR (PG)**

**TRIPURA**

1. AGTCCPP (NEEPCO)
2. KUMARGHAT (PG)
3. AGARTALA ( T & L OFFICE POWERGRID )

4. SURJAMANI NAGAR (TR)
5. UDAIPUR (TR)
6. DHARMANAGAR (TR)
7. PK BARI (TBCB) **FUTURE:** TO BE KEPT AT AGARTALA ( T & L OFFICE PGCIL)
8. SLDC

## **Methodology for taking generating station or unit(s) thereof under Reserve Shut Down (Day Ahead Condition.)**

- 1 The beneficiaries shall furnish their original requisition for the next day (D-day) to their respective NERLDC by 1500 hours of the current day (D-1) based on the entitlements given by the concerned NERLDC in accordance with the Grid Code, as amended from time to time.
- 2 Ex-Power Plant (Ex-PP) dispatch schedule of a generating station for each time block shall be computed by the respective NERLDC by taking algebraic sum of requisitions of all beneficiaries of that generating station by 1800 hours and same shall be uploaded on website for next day (D) by 1900 hours of current day (D-1). The Ex-PP schedule shall be restricted to On Bar DC.
- 3 If the net EX-PP injection schedule for a generating station is less than technical minimum, the beneficiaries shall be required to review their requisition(s) and submit a revised requisition(s), by 2000 hours of current day (D-1) to the concerned NERLDC.
- 4 Based on the revised requisitions received up to 2000 hours of current day (D- 1), NERLDC shall prepare revised injection schedule for the concerned generating station. If the scheduled injection is still less than technical minimum, NERLDC shall review the anticipated demand pattern based on the demand forecast and grid conditions to decide on the requirement of providing technical minimum schedule to the generating station.
- 5 NERLDC shall suo-moto revise the schedule of any generating station as per clauses 6.5.14 and 6.5.20 of the Grid Code to operate at or above technical minimum in the ratio of under-requisitioned quantum (with respect to technical minimum) in the interest of smooth system operation under the following conditions
  - a. Extreme variation in Weather Conditions
  - b. High Load Forecast
  - c. To maintain reserves on regional or all India basis
  - d. Network Congestion
  - e. Any other event which in the opinion of NERLDC/NLDC shall affect the grid security

While doing so, it is possible that the requisition of some beneficiaries may go up to ensure technical minimum. In this case, SLDCs may surrender power from some other inter-State generating station(s) or intra-State generating station(s) based on merit order. The concerned NERLDC shall issue R-1 schedule accordingly and this shall be intimated to the concerned generating station, through the scheduling process.

- 6 If the grid conditions do not demand for providing technical minimum to a generating station, NERLDC shall issue R-1 schedule based on the requisitions received. Under such situation, the generating station shall have the option to go for RSD with intimation to NERLDC latest by 2100 hrs.

- 7 If the grid conditions do not demand for providing technical minimum to a generating station, NERLDC shall publish the difference between technical minimum and schedule in MW required to run the unit(s) in technical minimum.
- 8 Before taking unit(s) under RSD, the generating station shall revise the On Bar DC (with due consideration to ramp up/down capability), Off Bar DC, DC and Ramp UP/RAMP Down rate. The generator shall ensure that the Off Bar DC is not more than the MCR less Normative Auxiliary Consumption of the machines under RSD. The beneficiaries shall continue to bear the capacity charge corresponding to Total DC.
- 9 When the machine is going under RSD :
  - a. In case the total requisitioned power can be supplied through other units in the same generating station on bar, the generator shall be scheduled according to the requisitions received.
  - b. In case total requisitioned power cannot be supplied through other units in the same generating station on bar, the requisition from the beneficiaries shall be reduced in the ratio of requisitioned power.
  - c. In the special case of a generating station where the only running machine is going under RSD, the beneficiaries who have requisitioned power will not get any power from that generating station. In such cases, the beneficiaries may make arrangement from alternative sources

**Methodology for taking generating station or unit(s) thereof under Reserve Shut Down (Real Time Schedule Revision)**

1. A beneficiary can surrender its part or full entitlement during the day of operation in accordance with the relevant provisions of Grid Code.

In case, the schedule of a generating station goes below technical minimum, due to this surrender of power:

- a. NERLDC may provide technical minimum schedule considering the system conditions in accordance with Regulations 6.5.14 and 6.5.20 of the Grid Code.
- b. In case the system condition does not require, NERLDC shall direct the generating station to take any unit or the generating station under RSD. In such a scenario, NERLDC shall display the station likely to go under RSD on its website. In case, the schedule is still less than the technical minimum and generating station decides to take a unit(s) under RSD, it shall inform the same to concerned NERLDC

### **Methodology for revival of generating station or unit(s) from RSD**

1. Once a unit is taken out under RSD, the generating station will be notified the period for which the unit will remain under RSD and the unit can be recalled anytime after 8 hours. In case of system requirements, the generating unit can be revived before 8 hrs as well.
2. One or more beneficiaries of the generating station as well as the generating station may decide for revival of unit(s) under RSD
  - a. Generating Station will inform NERLDC for revival of unit(s), with commitment from one or more beneficiaries.
  - b. Once time and commitment received, NERLDC will ensure technical minimum schedule with minimum run time of at least 8 hrs for Coal based generating stations and at least 3 hrs for Gas based generating stations post revival.
3. NERLDC may also advise the generating stations to revive unit(s) under RSD for better system operation (IEGC 6.5.20). In such cases, NERLDC shall ensure technical minimum schedule by increasing schedule of all the beneficiaries in the ratio of under-requisition.

**Annexure D-12(I)****Time Drift Report status**

<b>SL NO</b>	<b>PGCIL</b>	<b>STATUS</b>
1	PGCIL SALAKATI	REPORT NOT SENT/ACTION NONE
2	PGCIL NIRJULI	REPORT SENT BUT ACTION NONE
3	PGCIL BONGAIGA ON	IRREGULAR REPORTING
4	PGCIL BADARPUR	REPORT NOT SENT/ACTION NONE
5	PGCIL AIZAWL	REPORT NOT SENT/ACTION NONE
6	PGCIL SILCHAR	REPORT NOT SENT/ACTION NONE
7	PGCIL BNC	REPORT NOT SENT/ACTION NONE
8	PGCIL HAFLONG	REPORT NOT SENT/ACTION NONE
9	PGCIL MARIANI	REPORT NOT SENT/ACTION NONE
10	PGCIL MOKOKCHANG	REPORT NOT SENT/ACTION NONE
	<b>ASSAM</b>	
11	AZARA-BONG	ACTION NONE
12	AZARA-SIL	ACTION NONE
13	132 KV AGIA FEEDER	ACTION TAKEN
14	SAMAGURI END OF MISA-I FDR	ACTION TAKEN
15	SARUSAJAI S/S	NO ACTION/REPORT NOT SENT
16	TINSHUKIA S/S	NO ACTION/REPORT NOT SENT
17	UMRANGSOO S/S	NO ACTION/REPORT NOT SENT
18	SONABIL S/S	NO ACTION/REPORT NOT SENT
19	KAHELIPARA S/S	NO ACTION/REPORT NOT SENT
20	DULLA VCHERRA	REPORT SENT BUT ACTION NONE
	<b>ARUNACHAL</b>	
21	CHIMPU S/S	NO ACTION/REPORT NOT SENT
	<b>TRIPURA</b>	
22	79 TILLA S/S	NO ACTION/REPORT NOT SENT
23	SURJAMANI NAGAR S/S	NO ACTION/REPORT NOT SENT
24	UDAIPUR	NO ACTION/REPORT NOT SENT
	<b>MIZORAM</b>	
25	Kolasib s/s	NO ACTION/REPORT NOT SENT
	<b>NAGALAND</b>	
26	KOHIMA S/S	NO ACTION/REPORT NOT SENT
	<b>GENERATORS</b>	
27	DOYANG	REPORT NOT SENT
28	RHEP	REPORT NOT SENT
29	NTPC	REPORT SENT BUT ACTION NONE

## **Annexure D-12(II)**

### **Time Drift Corrective Action Not taken**

SL NO	ENTITY	LOCATION	TIME DRIFT STATUS(MIN)	REMARKS
1	ASSAM	AZARA-BONG	-3:55	Meter replaced due to high time drift but due to inaction drift >3
2	ASSAM	AZARA-SIL	-4:24	Meter replaced due to high time drift but due to inaction drift >4
3	ASSAM	DULLAVCHERRA	+2:20	No action taken

### **Locations not sending weekly SEM data**

SL NO	LOCATION NOT REPORTING	STATUS
1	UDAIPUR (TR)	DATA NOT SENT
2	MOKOKCHANG (NG) - DOYANG FDR	DATA NOT SENT
3	SONABIL(AS)	DATA NOT SENT

## Annexure D - 13

<b>PRIORITY LIST</b>		
SL NO	METER NO	FEEDER NAME WHERE INSTALLED EARLIER
1	9708	NTPC END CHECK METER
2	8368	RANGIA END OF MOTONGA
3	8380	MOTONGA END OF RANGIA
4	8383	TINSUKIA END OF KATHALGURI CKT-1
5	8386	TINSUKIA END OF KATHALGURI CKT-2
6	8374	IMPHAL(S) END OF IMPHAL(PG) CKT-2
7	8375	NINGTHOUKONG END OF LOKTAK
8	8500	JIRIBAM-PG END OF JBM-JBM FEEDER
9	8373	KARONG END OF KOHIMA
10	8374	IMPHAL(S) END OF IMP-IMP
11	9436	BONGAIGAON END OF BALIPARA-CKT-4
12	7603	PALATANA
13	8480	DIMAPUR
14	9451	DIMAPUR
15	9599	DIMAPUR
16	9449	DIMAPUR
17	9450	DIMAPUR
18	9601	DIMAPUR
19	8484	AGIA
20	8385	DIMAPUR
21	8481	DIMAPUR
22	5802	PALATANA
23	8669	IMPHAL
24	7596	HAILAKANDI
25	8802	AGTPP STG-2 STUPPOW
26	8372	TFR BAY AT NAHARLAGUN
27	8482	BOKAJAN END OF 66 kV DIMAPUR FEEDER
28	9073	NTPC 11 KV SECTION A CONST.
29	9058	NTPC 11 KV SECTION B CONST.
30	7588	NTPC END OF 400kV FDR -1_CHECK METER

## Annexure D-13

<b>LIST 2</b>		
1	5825	NIRJULI ICT-1
2	5824	NIRJULI ICT-2
3	6031	NIRJULI END OF 132 KV LEKHI
4	5771	NIRJULI END OF 132 KV GOHPUR
5	6950	IMPHAL(S) END OF IMPHAL(PG) CKT-1
6	5797	SAMAGURI END OF MISA CKT-1
7	5796	SAMAGURI END OF MISA CKT-2
8	6946	DULLAVCHERA END OF DHARMANAGR
9	6907	GOHPUR END OF NIRJULI
10	6857	RC'NAGAR
11	6858	RC'NAGAR
12	6559	RC'NAGAR
13	6864	RC'NAGAR
14	6853	RC'NAGAR
15	6852	RC'NAGAR
16	5812	NTPC END
17	5280	NTPC
18	5799	GTG1 meter OF PALATANA
19	6855	PALATANA END OF SLCHAR II FDR(check meter)
20	5785	KATHALGURI END OF 220kV MARIANI FDR
21	5784	KATHALGURI END OF 220kV MISA FDR
22	6885	KATHALGURI END OF 220kV DEOMALI FDR
23	5786	KATHALGURI END OF 220kV TINSUKIA FDR-1
24	5778	KATHALGURI END OF 220kV TINSUKIA FDR-2
25	5804	KATHALGURI GT-1
26	5805	KATHALGURI GT-2
27	5806	KATHALGURI GT-3
28	5807	KATHALGURI GT-4
29	5818	KATHALGURI GT-5
30	5819	KATHALGURI GT-6
31	5820	KATHALGURI GT-7
32	5822	KATHALGURI GT-8
33	5823	KATHALGURI GT-9
34	5789	KATHALGURI STN TRF- 1
35	5791	KATHALGURI STN TRF- 2
36	5780	KHANDONG END OF 132kV UMRANGSOO FDR
37	5809	KHANDONG END OF 132kV KHLRT FDR - 1
38	5774	KHANDONG END OF 132kV KHLRT FDR - 2
39	5773	KHANDONG END OF 132kV KOPILI FDR-1
40	6882	KHANDONG END OF KOPILI FDR-2
41	5783	KHANDONG 33 KV STN TRF
42	5779	KHANDONG GT- 1
43	6153	KHANDONG GT- 2
44	5810	KOPILI-II GT-2 OF STG-2
45	5776	KOPILI-II STG-2 33kV STN. TRF.
46	5279	NTPC 6.6 KV E7 STUP
47	5826	NTPC 6.6 KV E8 STUP
48	5281	NTPC END OF 400/220 KV ICT-2 LV SIDE