



भारत सरकार Government of India

विद्युत मंत्रालय Ministry of Power

उत्तर पूर्वी क्षेत्रीय विद्युत समिति

North Eastern Regional Power Committee

एन ई आर पी सी कॉम्प्लेक्स, डोंग पारमाओ, लापालाङ, शिल्लोंग-७९३००६, मेघालय
NERPC Complex, Dong Parmaw, Lapalang, Shillong - 793006, Meghalaya

Ph. No: 0364 - 2534039

Fax No: 0364 - 2534040

Website: www.nerpc.nic.in

No. NERPC/SE (O)/OCC/2019/418-455

Dated: April 25, 2019

To,

1. Managing Director, AEGCL, Bijuli Bhawan, Guwahati – 781 001
2. Managing Director, APDCL, Bijuli Bhawan, Guwahati – 781 001
3. Managing Director, APGCL, Bijuli Bhawan, Guwahati – 781 001
4. Director (Generation), Me. PGCL, Lumjingshai, Short Round Road, Shillong – 793 001
5. Director (Distribution), Me. ECL, Lumjingshai, Short Round Road, Shillong – 793 001
6. Director(Transmission), Me. PTCL, Lumjingshai, Short Round Road, Shillong – 793 001
7. Managing Director, MSPDCL, Secure Office Bldg. Complex, South Block, Imphal – 795 001
8. Managing Director, MSPCL, Electricity Complex, Keishampat, Imphal – 795 001
9. Director (Tech.), TSECL, Banamalipur, Agartala -799 001.
10. Director (Generation), TPGCL, Banamalipur, Agartala -799 001.
11. Chief Engineer (WE Zone), Department of Power, Govt. of Arunachal Pradesh, Itanagar- 791111
12. Chief Engineer (EE Zone), Department of Power, Govt. of Arunachal Pradesh, Itanagar- 791111
13. Chief Engineer (TP&MZ), Department of Power, Govt. of Arunachal Pradesh, Itanagar- 791111
14. Engineer-in-Chief (P&E), Department of Power, Govt. of Mizoram, Aizawl – 796 001
15. Chief Engineer (P), Department of Power, Govt. of Nagaland, Kohima – 797 001
16. CGM, (LDC), SLDC Complex, AEGCL, Kahilipara, Guwahati-781 019
17. Group General Manager, NTPC, Bongaigoan Thermal Power Project, P.O. Salakati, Kokrajhar- 783369
18. ED, NERTS, PGCIL, Dongtieh-Lower Nongrah, Lapalang, Shillong -793 006
19. ED (O&M), NEEPCO Ltd., Brookland Compound, Lower New Colony, Shillong-793003
20. ED (Commercial), NEEPCO Ltd., Brookland Compound, Lower New Colony, Shillong-793003
21. ED (O&M), NHPC, NHPC Office Complex, Sector-33, Faridabad, Haryana-121003
22. Vice President (Plant), OTPC, Badarghat Complex, Agartala, Tripura - 799014
23. GM, NERLDC, Dongtieh, Lower Nongrah, Lapalang, Shillong -793 006
24. Member Secretary, ERPC, 14 Golf Club Road, Tollygunge, Kolkata-700033
25. Chief Engineer, GM Division, Central Electricity Authority, New Delhi – 110066
26. Chief Engineer (NPC), NRPC Complex, Katwaria Sarai, SJSS Marg., New Delhi - 110016

Sub: Minutes of 155th OCC Meeting.

Sir/Madam,

Please find enclosed herewith the minutes of 155th OCC Meeting held at Guwahati on the **10th April, 2019** for your kind information and necessary action. The minute is also available on the website of NERPC, www.nerpc.nic.in.

Any comments/observations may kindly be communicated to NERPC Secretariat at the earliest.

Encl: As above

भवदीय / Yours faithfully,

बि. लिंगखोइ / B. Lyngkhoi

निदेशक / Director/ SE

Copy to:

1. CGM, AEGCL, Bijuli Bhavan, Guwahati - 781001
2. CGM, APGCL, Bijuli Bhavan, Guwahati - 781001
3. CGM, DISCOM, Bijuli Bhavan, Guwahati - 781001
4. Head of SLDC, Me.ECL, Lumjingshai, Short Round Road, Umjarain, Shillong – 793 022
5. Head of SLDC, Department of Power, Govt. of Arunachal Pradesh, Itanagar- 791 111
6. Head of SLDC, Department of Power, Dimapur, Nagaland
7. Head of SLDC, Electricity Department, Govt. of Manipur, Keishampat, Imphal – 795 001
8. Head of SLDC, Department of Power, Govt. of Mizoram, Aizawl – 796 001
9. Head of SLDC, TSECL, Agartala – 799 001
10. Chief Engineer(Elect), Loktak HEP, Vidyut Vihar, Kom Keirap, Manipur- 795124
11. Addl. GM (EED), NTPC Ltd., Bongaigoan Thermal Power Project, P.O. Salakati, Kokrajhar- 783369
12. DGM (C&M), OTPC, 6th Floor, A-Wing, IFCI Tower -61, Nehru Place, New Delhi – 110019.



निदेशक / Director/ SE

North Eastern Regional Power Committee

MINUTES OF THE 155th OPERATION COORDINATION

SUB-COMMITTEE MEETING OF NERPC

Date : 10/04/2019 (Wednesday)
Time : 10:00 hrs
Venue : "Hotel Nandan", Guwahati.

The List of Participants in the 155th OCC Meeting is attached at **Annexure – I**

Shri P.K. Mishra, Member Secretary, NERPC welcomed all the participants to the 155th OCC meeting. He stated that the "Study Tour on Integration of Renewables into the Grid" has been successfully concluded after the 3rd batch visit in March'2019. He hoped the training was fruitful and useful to all the participants as well as their organizations. Further, he informed that NTPC & PGCIL had submitted their training programs for 2019-20, which will be finalized in April'19 as per requirements of the different utilities. He apprised the members that SAMAST is still in approval with the schemes of Assam and Meghalaya being approved till date. For ADMS tender has been prepared and will be published by 20th April'2019. He requested the utilities especially the state utilities to send their nominations for Technical & Financial Evaluation Committee at the earliest. He also mentioned & thanked NERLDC that long pending SLD of Communication networks in NER has been prepared and completed.

Thereafter, Member Secretary requested Shri B. Lyngkhoi, Director (O&P) to take up the agenda for discussion.

A. CONFIRMATION OF MINUTES

CONFIRMATION OF MINUTES OF 154th MEETING OF OPERATION SUB-COMMITTEE OF NERPC.

The minutes of 154th meeting of Operation Sub-committee held on 13th March, 2019 at Guwahati were circulated vide letter No. NERPC/SE (O)/OCC/2016/4556-4591 dated 25th March, 2019.

The Sub-committee confirmed the minutes of 154th OCCM of NERPC as no comments/observations were received from the constituents.

ITEMS FOR DISCUSSION

B.1. ACTION TAKEN:**1. IMPLEMENTATION OF PROJECTS FUNDED FROM PSDF:**The status as informed in 155th OCC:

State	R&U scheme	ADMS	Capacitor Installation	SAMAST **	Line Differential Protection
Ar. Pradesh	Could not be updated due to absence of DoP Ar. Pradesh representative	Tender to be published by April'19	-	TESG queries submitted.	-
Nagaland	Could not be updated due to absence of DoP Nagaland representative		To re-submit proposal to NERPC for Study.	TESG queries to be submitted.	Lines identified. Under DPR preparation stage.
Mizoram	Could not be updated due to absence of P&ED Mizoram representative		To re-submit proposal to NERPC for Study.	TESG queries submitted.	Lines not yet identified. To be taken up in Sub-group.
Manipur	LOAs issued. Completion by Jun'19.		Submitted to NERPC for Study before sending to NPC/NLDC.	TESG queries to be submitted.	Lines not yet identified. To be taken up in Sub-group.
Tripura	90% completed. Remaining by May'19		To submit proposal to NERPC for Study.	TESG queries submitted.	Lines not yet identified. To be taken up in Sub-group.
Assam	LOAs issued. Completion by Jun'19.		-	Appraisal Committee approved.	Lines identified. Under DPR preparation stage.
Meghalaya	MePTCL LOAs issued. Completion by Jun'19. MePGCL - Erection complete by Mar'19		-	Appraisal Committee approved.	DPR already submitted and awaited approval.

Deliberation of the sub-Committee:

Director, NERPC requested all states to submit a station-wise status for progress of works i.r.o. R&U works of sub-stations so that the physical & financial progress of PSDF can be monitored. Further, he stated that the ADMS NIT would be floated by 20th April, 2019 and also apprised the forum of the payment conditions. Also, he informed that during TESHG meeting only the SAMAST DPR for Assam and Meghalaya has been considered for further action. The forum requested NERPC & NERLDC to take up with NPC/NLDC in this regard

The Sub-Committee noted as above.

Action: All state utilities/NERPC.

2. Outage of Important Grid Elements:

Name of the Element	Name of Utility	Status as informed in 155 th OCC
63MVAR Reactor at Byrnihat to replace with 80MVAR Reactor	MePTCL	NERPC will write to CEA for inclusion in NERSCT's MoM.
Outage of 420kV 80MVAR L/R for 400kV Bongaigaon-NSLG-I at Bongaigaon - (out since 04.07.18)	NERTS	Reactor charged on 08.04.19. Issue may be dropped
132kV Dimapur - Imphal (out since 25.07.18)	NERTS	The completion schedule can only be provided once the ROW issue of Kohima portion is resolved by Nagaland.
220kV Sonabil-Samaguri-I	AEGCL	LOA by March, 2019
420kV 63 MVAR Line Reactor at 400 kV Bongaigaon S/S for 400kV Bongaigaon- Azara(out since Nov'18)	NERTS	Testing of Reactor is completed. Clearance from OEM is awaited. Expected to be charged by 15th April'19

The Sub-Committee noted as above.

Action: All concerned utilities & NERPC.

3. Submission of various data pertaining to reliable operation of the grid:

Details of the data required	Name of Utility	Status of submission as per 155 th OCC
Primary response testing of generators: The make, vintage, kind of governor and whether facility for simulated signal input to governor is there or not	NTPC, NHPC	By 30 th April, 2019

Data for Wind Turbine Generator

All SLDCs

By 30th April, 2019**B.2. OPERATIONAL PERFORMANCE AND GRID DISCIPLINE DURING MARCH, 2019**

As per the data made available by NERLDC, the grid performance parameters for March, 2019 are given below:

NER PERFORMANCE DURING MARCH, 2019

States	Energy Met (MU)		w.r.t. Feb,19 % inc (+) /dec (-)	Energy Reqr. (MU)		w.r.t. Feb,19 % inc (+) /dec (-)	% inc (+) /dec (-) of energy reqr vs met. In Mar,19
	Mar-19	Feb-19		Mar-19	Feb-19		
Ar. Pradesh	60.49	76.93	-21.37	60.87	77.28	-21.23	-0.62
Assam	656.48	621.73	5.59	679.52	635.00	7.01	-3.39
Manipur	67.51	94.74	-28.74	68.13	95.46	-28.63	-0.91
Meghalaya	172.78	188.34	-8.26	173.24	188.35	-8.02	-0.27
Mizoram	49.37	70.46	-29.93	49.80	70.98	-29.84	-0.86
Nagaland	57.29	77.40	-25.98	58.48	85.74	-31.79	-2.03
Tripura	89.94	147.46	-39.01	90.25	148.35	-39.16	-0.34
Region	1153.87	1277.05	-9.65	1180.30	1301.15	-9.29	-2.24

States	Demand Met (MW)		w.r.t. Feb,19 % inc (+) /dec (-)	Demand in (MW)		w.r.t. Feb,19 % inc (+) /dec (-)	% inc (+) /dec (-) of energy reqr vs met. In Mar,19
	Mar-19	Feb-19		Mar-19	Feb-19		
Ar. Pradesh	131	148	-11.49	133	138	-3.62	-1.50
Assam	1508	1440	4.72	1539	1417	8.61	-2.01
Manipur	199	194	2.58	204	192	6.25	-2.45
Meghalaya	357	356	0.28	357	355	0.56	0.00
Mizoram	105	109	-3.67	108	102	5.88	-2.78
Nagaland	125	132	-5.30	127	130	-2.31	-1.57
Tripura	249	231	7.79	249	231	7.79	0.00
Region	2535	2514	0.84	2540	2480	2.42	-0.20

REGIONAL GENERATION & INTER-REGIONAL EXCHANGE IN MU**AVERAGE FREQUENCY (Hz)**

Month---->	Mar-19	Feb-19
Total Generation in NER (Gross)	1240.164	1101.311
Total Central Sector Generation (Gross)	977.118	841.084
Total State Sector Generation (Gross)	263.046	260.227
Inter-Regional Energy Exchange		
(a) NER-ER	312.59	184.75
(b) ER-NER	5.13	1.07
(c) NER-NR	0.00	4163.00
(d) NR-NER	381.85	45.83
© Net Import	74.39	-4300.85

Month---->	Mar-19	Feb-19
	% of Time	% of Time
Below 49.9 Hz	7.23	7.23
Between 49.9 to 50.05 Hz	70.92	70.92
Above 50.05 Hz	21.85	21.85
Average	50.00	50.00
Maximum	50.26	50.26
Minimum	49.68	49.68

Deliberation of the sub-Committee:

NERLDC gave a presentation on the grid performance for the financial year 2018-2019 (**Annexure-B.2-a**). NERLDC also highlighted that Daily, Weekly and Monthly Voltage Deviation Report, Frequency Deviation Report and System Reliability Report for March'19 was already mailed to all the constituents for necessary actions. Further, it was informed that members may access these reports from NERLDC website under the tab CERC KPI Reports. NERLDC informed the forum about the number of lines kept open on high voltage. NERLDC again requested for early restoration of reactors which are under long outage and commissioning of new reactors at the earliest as mentioned in Sl. No. B.1.2 and C.1 and support from Generator to control voltage so that it does not require to open lines for maintaining voltage profile within IEGC band. Following issues were highlighted by NERLDC in the presentation:

1) NERLDC highlighted the tripping details for the year 2018-19:

Total tripping	1062 nos
400kV	163 nos
220kV	129 nos
132kV	770 nos

NERLDC stated that there were total 1062 tripping in 2018-19 which compromised reliability of Grid. It was seen that tripping was higher in monsoon which was largely attributed to lightning strikes.

Sr.GM(AM), NERTS stated that the isokeraunic level of NER is very high, hence numerous lines are tripping especially 132kV lines during monsoon. To reduce this, POWERGRID is presently installing TLSA as well as improving the tower earthing with chemical treatment. The forum appreciated the activities undertaken by NERTS. Members decided that once POWERGRID submits a report on the effectiveness of the above activities, state utilities would also undertake the activities with funding from PSDF.

In the meantime, the forum requested all the STUs to complete the following activities:-

- Identification of lines under high isokeraunic zone or lines tripping numerous times due to lightning.
- Tower footing resistance measurement for the above identified lines.

It was decided that tripping statistics would be shown in every OCC meeting.

2) Grid Disturbance / Grid Incidents in NER

The number of grid disturbances in 2018-19 had reduced compared to 2017-18 while the number of Grid Incidences had increased compared to the preceding year. It was shown that during 2018-19, there were 206 GDs and 135 GIs in NER which was considerably higher than other Regions. It was agreed that monthly GDs / GIs statistics would be shown in every OCC with probable measures to avoid the same.

3) Zero crossing violation

It was shown that the States of Ar. Pradesh, Mizoram and Nagaland had very large numbers of violations in Jan and Feb'19 which needed to be reduced.

4) Stagnant growth of Power in NER

It was shown by NERLDC that growth in terms of MW as well as MU in NER remained stagnant over past two years and it was a matter of concern for the Region. The forum decided to take up this matter in the next TCC/RPC meeting.

The Sub-Committee noted as above.

ITEMS FOR DISCUSSION

C. OLD ITEMS

1. Status of Generating Units, Transmission Lines in NER:

During 155th OCC meeting, the status as informed by different beneficiaries is as follows:

SN	Items	Status as given in 154 th OCC Meeting		Status as given in 155 th OCC Meeting	
		Timeline for completion	Timeline for completion	Timeline for completion	Furnishing of detail parameters
a. New Elements					
1	250 MW BgTPP Unit #III	By Mar'19	To be submitted to NERLDC.	DoCO on 26.03.2019	To be submitted to NERLDC.
2	400/220kV, 315 MVA ICT-1 of NTPC at Bongaigaon	By Mar'19	To be submitted to NERLDC.	By Apr'19	To be submitted to NERLDC.
3	Kameng HEP of NEEPCO two units (2 x 150 MW) Next two units	By July'19	Already submitted.	By July'19	Already submitted.

	(2x150 MW)				
4	132kV Monarchak – Surjamaninagar D/C of TSECL	by Jun'19	To be submitted to NERLDC.	by Jun'19	To be submitted to NERLDC.
5	400/220 kV 315 MVA ICT-II at Bongaigaon	LV side (GIS) is expected to be completed by Apr'19.	LV side separate application to be submitted	Commissioned on March'19. To be dropped.	Submitted
6	220/132 kV, 160MVA ICT-II at Balipara	Apr'19	To be submitted to NERLDC.	Apr'19	To be submitted to NERLDC.
7	220/132 kV, 1x160 MVA ICT with GIS Bay at Kopili	Apr'19	To be submitted to NERLDC.	Apr'19	To be submitted to NERLDC.
8	Dedicated 33kV feeder at Khliehriat Substation from Lumshnong.	To be taken up with MePDCL. SLDC to kindly mediate.	Not applicable.	To be taken up with MePDCL. SLDC to kindly mediate.	Not applicable.
9	Replacement of 2x315 MVA ICTs with 2x500 MVA ICTs at Misa (PG)	<ul style="list-style-type: none"> • ICT-I Expected by March'19 without Tertiary connectivity of 4X25MVAR Tertiary Reactors and • ICT-II Expected by Jun'19 	To be submitted to NERLDC.	<ul style="list-style-type: none"> • ICT-1 Charged on March'19. To be dropped. • ICT – II Expected by June'19 	ICT-I submitted
10	220kV Balipara- Sonabil-2	AEGCL will intimate the status in next OCC Meeting	-	AEGCL will intimate the status in next OCC Meeting	-
b. Elements under breakdown/upgradation					
11	Up-gradation of 132 kV Lumshnong- Panchgram line	DPR sent to NLDC/NPC	Not applicable.	DPR sent to NLDC/NPC	Not applicable.
12	PLCC Panels at Loktak end of Loktak – Ningthoukhong 132 kV feeder and Loktak - Rengpang 132 kV feeder	May'19	Not applicable.	May'19	Not applicable.
13	Replacement of CTs and	Expected Completion :	Not applicable	Expected Completion :	Not applicable

	installation of Bus Bar Protection at 220 kV Misa	Apr'19		Apr'19	
14	Upgradation of 132 kV Bus Bar at Umiam Stg-III to ACSR Zebra	DPR will be submitted soon.	Not applicable	DPR will be submitted soon.	Not applicable
15	220/132 kV 30 MVA ICT at Mokokchung	Mar'19(LOA date) to be reviewed later on.	To be submitted to NERLDC	Mar'19(LOA date) to be reviewed later on.	To be submitted to NERLDC

The Sub-Committee noted as above.

Action: All state utilities/central utilities/NERPC.

C.2. Update on Real Time Energy Assessment for Effective Grid Management:

In 154th OCC meeting, the following were decided:

- CDAC to complete installation of TARA devices by 31.03.2019.
- Integration of WBES schedule & SMS alert app to be deployed by CDAC

NERTS has been advised to complete installation/replacement of SEMs as per list below –

SL NO	FEEDER NAME	STATUS	METER TO BE REPLACED/INSTALLED BY PGCIL	Status
1	SRIKONA END OF 132kV SILCHAR FDR -1	REPLACE	1	Completed
2	SRIKONA END OF 132kV SILCHAR FDR -2	REPLACE	1	
3	MOKOK(S) END OF MOKOK-MOKOK-1	REPLACE	1	Completed
4	MOKOK(S) END OF MOKOK-MOKOK-2	REPLACE	1	
5	KHUPI END OF 132 KV BALIPARA	INSTALL	1	Completed
6	KHUPI END OF 132 KV KAMENG	INSTALL	1	
7	ZUANGTUI END OF MELRIAT	INSTALL	1	Letter given to state for providing necessary permission for fitting of new meters. Reply awaiting
8	LUANGMOL END OF AIZAWL	INSTALL	1	

Deliberation of the sub-Committee:

Director, NERPC informed that the CDAC project is on the verge of completion with the following activities pending:-

- TARA devices to be installed for the above replaced SEMs
- WBES schedule integration to be done.

The forum decided that formal project inauguration be done in April'19. Sr. Manager, TSECL informed that Server Installation & Commissioning at SLDC Agartala is yet to be done by CDAC and requested them to complete at the earliest.

The Sub-Committee noted as above.

Action: All state utilities/central utilities/NERPC.

C.3. Ensuring proper functioning of Under Frequency Relays(UFR) & df/dt Relays:

In 7th NPC meeting held on 08.09.17 it was agreed that mock test is good enough to test the healthiness of the UFR & df/dt relays. The frequency of site inspection was proposed to be upto six months. RPC may carry out periodic inspection, in line with provisions of IEGC and furnish inspection reports to NPC.

Discussions as per previous meetings:

- Inspection for Mawphlang completed.
- Inspection for Baghjar, Sankardevnagar and Sipajhar under Assam would be tentatively done by 1st week of Mar'19.

Deliberation of the sub-Committee:

Director, NERPC informed that due to pre-occupation, NERPC could not finalize the date for inspection and expressed deeply regretted. The inspection will be carried out by team of NERPC, NERLDC, NERTS & Assam from 29.04.19 - 30.04.19.

The Sub-Committee noted as above.

Action: NERPC.

C.4. Extended C Band VSAT for power system communications in NER:

As per discussion in previous meetings:

- Leased Line Connectivity has been explored by NERTS for Roing, Tezu & Namsai with recurring expenditure amounting to INR 28 lakhs.
- VSAT Pilot project to be executed at Byrnihat station. The data would be transmitted from Byrnihat to KPTCL (via satellite) to SRLDC to NLDC to NERLDC. This would be kept in monitoring mode in the interim. Pilot project cost breakup is to be put up for approval in the next TCC/RPC meeting. NERLDC has

requested for finalisation of modality for VSAT pilot project. Quotation enclosed as Annexure-21

- NERPC to take up with proper authorities for funding of VSAT in NER from suitable sources.
- Financial impact for NER states i.r.o. VSAT for Roing, Tezu, Namsai by POWERGRID is to be explored (tentative cost is ₹ 54,653,880.00 for 5 years). matter has been referred to Corporate LD&C.
- Technical visit on 10.12.2018 concluded that VSAT for NER is technically feasible.

In 154th OCCM, CGM, NERLDC requested to finalize modalities regarding the pilot project. After detailed deliberation, the OCC decided that since the project is a pilot one, the order may be given to M/s KPTCL.

Director, NERPC requested NERLDC to intimate the exact cost of above pilot project for one year so that the same can be endorsed in the next TCC/NERPC Meetings.

Deliberation of the sub-Committee:

CGM, NERLDC informed that the pilot project has been awarded to M/s KPTCL and is slated for completion in May'2019. Upon enquiry of TSECL, Director NERPC clarified that the cost of the pilot project would be shared amongst all the 12 utilities and the same will be put up in next TCC/RPC Meetings for endorsement.

The Sub-Committee noted as above.

Action: NERPC/NERLDC.

C.5. DIMAPUR_PG Voice communication and telemetry out since Feb'18.

In 154th OCCM NERTS informed that as per 148th OCC meeting the voice has already been restored on March'18. LOA has been placed to M/s GE which include both supply and installation. To be completed by June'19. However all the analog signals has been made through and also almost 80% digital signals are also reporting.

Deliberation of the sub-Committee:

NERTS informed that voice communication is available at the moment and telemetry would be made available by July'2019.

The Sub-Committee noted as above.

Action: NERTS.

C.6 Update on PDMS:

As per deliberation in the previous meeting(s) the following status/decisions:-

- Operational load flow has been completed and circulated to all constituents for comments. *SLDCs may please update the status.*
- Database building and network modelling for Assam has been completed.
- Server installation at NERPC to commence in March'19.
- Assam SAT w.e.f. 25.03.19 to 28.03.19. M/s PRDC to circulate the verifiable documents.
- Data collection for Meghalaya would commence in April'19.
- A technical committee would be formed with protection experts from various utilities.

Deliberation of the sub-Committee:

M/s PRDC representative informed the forum that network modelling and database building for Assam has been completed and SAT may be done. She also informed that the comments against the operational load flow is awaited. The forum decided the following:-

- SAT for Assam system from 06th May, 2019 to 10th May, 2019.
- One representative from each of the states and NEEPCO, NERTS, NERLDC and NERPC.
- Operational load flow feedback to be given by the SLDCs and NERLDC by 30.04.19.

The Sub-Committee noted as above.

Action: PRDC/all SLDCs/NERPC.

C.7 Non-availability/ Non-functioning of synchronization facility at numerous stations

As per deliberations in the previous the following is the status for synchronization facility at stations of different utilities:

- NERTS – All stations synchronization facility available. The same is available at RTAMC. Sync check to be tested for 132kV AGTCCPP-Kumarghat on 16.02.19- To be tested again during the Mock Black Start of AGTCCPP generation scheduled to be held in April, 2019. **NERTS status** Synch check has been tested on 09.04.19 during Mock Black Start of AGTCCPP generation and found OK. **To be dropped**

- AEGCL – Sync check not available for 132kV stations. Procurement of synchronizing trolley and associated equipments(sockets etc.) to be completed. LOA date to be intimated by AEGCL. **AEGCL status** - Tender in May'19
- DoP Ar. Pradesh – Sync check not available at Lekhi and Chimpu. Would be in place by Sep'19. **DoP Ar. Pradesh no representative.**

The Sub-Committee noted as above.

Action: All concerned Utilities.

C.8 Phase shift errors in PMU:

In 153rd OCCM Sr.GM, NERTS informed that the 220kV of NER has phase matching with 220kV ER(Birpara). So, at present it is not recommended to change at primary as downstream will be affected. After detailed deliberations, the forum decided that wirings in the secondary may be changed. In this regard, a matrix is to be made for changing the connections. Since PMU is not installed in all ISTS elements, concerned utilities are requested to trigger DR output manually for all ISTS elements and submitted to NERPC/NERLDC for preparation of the matrix. It was decided that a team from NERPC (Sh Srijit Mukherjee), NERTS (Sh. Supriya Paul/Devaprasad Paul), NERLDC (Sh. Zerin Jacob) & AEGCL (Sh. Abhishek Kalita) will identify the exact problem at Silchar, Misa & Sarusajai by Feb'19.

Deliberation of the sub-Committee:

Director, NERPC informed that in the Sub-group meeting held on 05.04.19, it was agreed that the matrix of phase comparison for each of the stations vs Bongaigaon will be prepared by NERLDC. NERLDC informed that work is underway and would be completed by April'19.

The Sub-Committee noted as above.

Action: NERLDC

C.9 Compensation for Heat Rate degradation and Auxiliary Energy Consumption in case of gas based power plants:

In 153rd OCCM it was decided that a Special Meeting would be convened prior to the 153rd OCC to discuss the Heat Rate Degradation and Compensation Calculation for Thermal Power Plants.

Deliberation of the sub-Committee:

It was agreed that the matter would be discussed in Special Meeting to be held in Agartala on 02nd May, 2019.

The Sub-Committee noted as above.

Action: NERPC

C.10 Operation of RHEP units in Synchronous condenser mode

In 153rd OCCM, Sr. Manager, NEEPCO informed that prima-facie it appears that Synchronous Condenser mode operation is not possible. However NEEPCO has written to BHEL(Bhopal) for solution. This item would be reviewed in the next meeting.

Details enclosed as **Annexure-C.14**

In 154th OCCM NEEPCO informed that M/s BHEL has informed that as per design of turbine and generator the generator can work in synchronous condenser mode. However the embedded pipe, air compressed system, DVR, protection logic etc. as per 2nd stage foundation drawing is not in place. This is in scope of NEEPCO. Further it was informed that the matter has been taken up with BHEL and the reply is awaited by mid April'19. The same will be intimated to the forum accordingly.

Deliberation of the sub-Committee:

Sr. Manager, NEEPCO informed that there has been no response from BHEL in this regard. He requested NERPC to intervene in the matter with BHEL. Member Secretary assured that the matter would be taken up strongly with BHEL through CEA.

NERLDC highlighted that during 2018-19, 400 KV BNC-Ranganadi lines were opened on 197 occasions due to high voltage at RHEP thereby reducing reliability of the Grid. This emphasised need of operation of RHEP units on synchronous condenser mode.

The Sub-Committee noted as above.

Action: NEEPCO.

C.11 Accurate Load forecasting by SLDCs as per IEGC c1.5.3 for better system operation

In 153rd OCCM NERLDC presented the RMSE for the month of Dec'18:

% Error with Actual Data (Forecasted by States)							
	Ar Pradesh	Assam	Manipur	Meghalaya	Mizoram	Nagaland	Tripura

Median	10	8	11	10	12	12	8
---------------	-----------	----------	-----------	-----------	-----------	-----------	----------

Mizoram & Arunachal Pradesh SLDCs are requested to check the methodology for improving the load forecast.

In 154th OCCM Mizoram informed that the issue will be intimated in the next OCC. Ar. Pradesh could not be updated due to absence of representative.

Deliberation of the sub-Committee:

NERLDC presented the RMSE for the month of Feb'19

% Error with Actual Data (Forecasted by States)							
	Ar Pradesh	Assam	Manipur	Meghalaya	Mizoram	Nagaland	Tripura
Median	10	8	11	12	10	12	8

Forum decided that load forecast error will be monitored in OCC Meeting till the RMSE comes below 5%

CGM, NERLDC informed that presently NERLDC is pursuing Industry - Academia partnership for better load forecasting. SLDCs may also join since the facility would not entail any expenditure on their part.

The Sub-Committee noted as above.

Action: All SLDCs/NERLDC

C.12 Construction of Bay for 132kV Agia-Nongalbibra Line at 220kV Agia Sub Station, Agia, Assam

Stringing of 2nd Circuit 132kV Nongalbibra -Agia Line (SPA Scheme) Rs. 1.11 Cr Deposited by MePTCL by SBI Chq No. 511140 Dt. 15.03.2016 for the above work. Stringing of the Line Completed in 2018.

MePTCL requested AEGCL to kindly intimate the latest status at the earliest.

In 154th OCCM Meghalaya informed that stringing of line in their portion is almost completed.

AEGCL informed that C&R panels is yet to be installed. For this temporarily Non-SAS compatible panel would be diverted from other site. By Apr'19

Deliberation of the sub-Committee:

AEGCL representative stated that Specifications for SAS compatible C&R panel has been prepared and awaits approval of DPC. The LOA would be done by May'19. The forum decided to review the status under item No. C.1.

The Sub-Committee noted as above.

Action: AEGCL

C. 13 Tentative schedule for Black Start & Restoration Procedure Mock exercise in NER during the year 2019

In 154th OCCM the mock black start schedule was agreed as below:

AGTCCPP: 09-04-19

LOKTAK: 12-04-19

Khandong: 06-06-19

KOPILI: 07-05-19

RHEP: 1st week of June'19

DOYANG: 2nd week of June'19

Deliberation of the sub-Committee:

NERLDC informed that Black Start exercise has been completed for AGTCCPP as per schedule. The date(s) for Kopili and Khandong stands modified as below:

Kopili HEP - 06th May, 2019

Khandong HEP - 07th May, 2019

Due to frequent disturbance in Manipur area on account of inclement weather condition, mock black start of Loktak would be carried out later on.

The Sub-Committee noted as above.

Action: NEEPCO, NHPC, NERLDC.

C. 14 DVAR and PSS at AGTCCPP:

Expected date of commissioning of DVAR and PSS at AGTCCPP. Letter No NERLDC/SO-II/2798 dated 22.02.19 regarding low frequency oscillations observed at Agartala PMU is enclosed as Annexure C.20.a. Oscillation observed in AGTCCPP Bus during low loading and synchronization of Unit 1 (Details are enclosed as Annexure-C.20.b.

DVAR, PSS - at site. rheap full s/d kopili s/d thermal power station s/d not possible

154th OCCM Sr. Manager, NEEPCO informed that the DVAR & PSS have already arrived at site and the same is to be commissioned now. AGTCCPP informed the FORUM that they changed the control system for Unit I. After the return of Unit 4, they will replace old AVR with DVAR along with PSS tentatively by April'19.

Deliberation of the sub-Committee:

Sr. Manager, NEEPCO informed that AGTCCPP Unit#4 would be returned by the end of April'19. Subsequently old AVR will be replaced with DAVR along with PSS tentatively by June 2019 as minimum 10 days required for installation of DAVR per

unit.

The Sub-Committee noted as above.

Action: NEEPCO

C. 15 Bus Configuration issues for various sub-stations:

Distribution of 132 kV lines in both 132 kV Bus-1 & Bus-2 at Surajmaninagar for reliable operation. Action is to be taken by TSECL.

400kV Bus-A at Ranganadi & 132 kV Transfer Bus at Loktak are not commissioned as per the scheme since inception.

The 154th OCC forum requested TSECL for distribution of feeders in both the bus. It was also highlighted that in S.M. Nagar- phase sequence has to be ensured between Bus-2 and transfer Bus. TSECL mentioned that they would revert with timeline.

Regarding 400kV Bus-A at Ranganadi, NEEPCO requested NERPC to write to NEEPCO Management about the non-availability, as it is not proper to operate in single bus.

Regarding transfer bus at Loktak, NHPC informed that the same would be ready by Jun'19. In addition, NERPC informed that they will write a letter for both 400 Bus-A at Ranganadi and 132kV Transfer Bus at Loktak.

Deliberation of the sub-Committee:

Director, NERPC stated that communication regarding bus configuration has been sent to TSECL, NHPC and NEEPCO vide letter dated. 01.04.19. Sr.GM(AM), NERTS once again reiterated that at Surjamaninagar only matching of phases between the buses needs to be done prior to connection. The forum requested TSECL to immediately complete the work since it requires minimum time and effort. This matter will be reviewed in Meeting of 2nd and 3rd May, 2019 at Agartala, in presence of members from NERPC, NERLDC, Power grid, Tripura, and other states. Manager, NHPC informed that CEA Inspection Application has been done for the 132kV Transfer Bus. NEEPCO stated that the work would be completed by 30.04.19.

The Sub-Committee noted as above.

Action: NEEPCO/TSECL/NHPC

C. 16 Reactive power capability/injection of generating stations:

1. Tentative schedule for Reactive Power Capability testing of generating units- Tentative date for testing at Pare is 05.04.2019
2. Palatana units are not capable of regulating MVAR absorption/injection as the units are in AVR mode. Manual VAR regulation is not possible as informed by Palatana.

The 154th OCC forum requested all generators to strictly follow their capability curve.

NERLDC has informed that Palatana response not adequate as discussed in 154th meeting. (**Annexure-C.16**)

Deliberation of the sub-Committee:

Sr. Manager, NEEPCO stated that for Pare HEP date would be confirmed after consultation with OEM. Further the curve/data obtained at the time of commissioning would be shared with NERLDC.

The forum once again expressed that Palatana response is not adequate and requested OTPC to take action in this regard.

NERLDC showed reactive generation / absorption of OTPC units during 2018-19 and it was established that the units were not absorbing reactive power.

OTPC informed that a letter has been written to OEM to change settings. Also, GT tap settings are being lowered.

The Sub-Committee noted as above.

Action: NEEPCO/OTPC

C. 17 Metering Status Review:

- i. Procurement of additional 70 Laptops

NERTS status - The LOA has already been placed. However the party raised some contractual queries which have been resolved. As such the party shall give tentative schedule of installation of the software. Target 15th May'19.

- ii. Non-receipt of SEM Time Drift Report (**Annexure-C.17**)

NERLDC deliberated that many SEMs were replaced in the recent past as the time drift was high in the old SEMs . But due to non corrective action by some of the constituents ,the time drift for some of the new SEMs also increased. NERLDC once again requested the constituents to take regular corrective action for reducing the time drift of SEMs .

The Sub-Committee noted as above.

D. NEW ITEMS

D.1 Generation Planning (ongoing and planned outages)

NEEPCO/NHPC may kindly intimate the availability for hydro stations:

- a. Present per day MU and projected number of days of operation.

Plants	Reservoirs level in meter as on 13-03-19	MU content	Present DC (in MU)	No of days as per current generation
Khandong + Kopili stg II	708.6	4.5	0.123	37
Kopili	597.7	37.9	0.74325	51
Doyang	306.35	0.39	0.048	8
Loktak	767.1	15.2	0.366	42

Thus, for maintaining the generation availability of NER Region it is requested to all hydro generations to judiciously plan the utilization of water and furnish the day ahead declared MU such that NER Region does not face lack of generation availability in the upcoming lean hydro season.

The outage of other generating stations may be approved considering the present water levels in reservoirs.

Deliberation in the Meeting:

The forum felt that in view of large number of shutdown underway for Hydel power stations requested all thermal stations to defer approved shutdown/forced outage till such time, when RHEP is returned to service.

The Committee discussed and approved the proposed shutdown by Generating Stations and the same has already been uploaded in the website of NERPC.

Action: All generating utilities/NERLDC.

D.2 Outage Planning Transmission elements

It was agreed in the 99th OCC meeting that shutdown will be availed only after approval is given by the OCC forum. It was also agreed that deferment/revision of outages elements other than already approved in OCC will be henceforth put/displayed in the website of NERPC (**under Operational Activities/OCC**

Approved shutdown) as per CERC regulations/ CEA guidelines etc for ensuring smooth & secure grid operation.

Furnishing request of shut down of the element, which was approved by NERPC, by Indenting Agency (ISTS licensees/STUs/Generating Companies) to NERLDC:

Planned shutdown approved by NERPC shall be considered for implementation by NERLDC on D-3 basis. If an outage is to be availed on say 10th of the month, the shutdown availing agency would reconfirm to NERLDC on 7th of the month by 10:00 Hr. This practice is necessary to ensure optimal capacity utilization and the time required for associated system study/coordination by/amongst RLDC/NLDC.

In 134th OCCM, it was decided that all communication related shutdown be approved in OCC forum only.

In 142nd OCCM, Director (O&P), NERPC suggested that henceforth shutdown list may be prepared under following categories:

- (i) New Construction Related Shut Down
- (ii) Existing System Improvement Related Shut Down.
- (iii) Existing System Normal Maintenance Related Shut Down
- (iv) Communication Related Shutdown
- (v) R&U works Related Shut Down under PSDF

The forum further decided that the modalities of communication related shutdown should be finalized. Members requested NERPC to invite POWERGRID telecom in next OCCM alongwith with officials (handling communication issues) from all utilities for this purpose.

Deliberation in the Meeting:

NERLDC highlighted that during 2018-19, against OCC approved shutdown of 1068 nos, emergency shutdown was 351 nos which was as high as 33% in average (specifically higher in monsoon months). It was agreed that an analysis would be made every month in OCC and all utilities would take preventive measures to avoid emergency S/D.

It was shown that during 2018-19, total 1116 nos S/D were availed out of approved 1494. Non-availing of such large numbers is creating coordination issues. It was agreed that utilities not availing S/D would intimate justification of same and rescheduling would only be considered in next OCC.

The sub-Committee discussed and approved the proposals received from the constituents regarding transmission elements and generating units for April, 2019-May, 2019 and the same has already been uploaded in website of NERPC.

D.3 Estimated Transmission Availability Certificate (TAC) for the month of December, 2018 to February, 2019:

NETC and POWERGRID have submitted the outage data for the month of December 2018 - February, 2019. So the attributability of outage of the said elements may please be finalized.

NERTS has informed that in order to process the monthly energy billing in time, it is desirable that within 30(thirty) days availability certificate is issued. It is to be deliberated how to issue the availability certificate within 30(thirty) days.

Deliberation in the Meeting:

NERLDC informed the forum that outage data of NERTS for the month of Mar'19 was received on 8th Apr'19 and observations/comments of NERLDC were mailed on 9th Mar'19. NERTS was requested to submit the revised outage data at the earliest for verification. NERLDC informed the forum that outage data of NETC for the month of Mar'19 was received on 10th Apr'19.

NERLDC requested NETC & NERTS to submit the data to NERLDC by 5th of the month, so that verification can be completed within 15 days after submission of documents/data as per procedures.

The Sub-Committee noted as above.

Action: Concerned transmission utilities/NERLDC/NERPC

D.4 RGMO performance analysis of events

In 153rd OCCM, NERLDC presented a report on RGMO performance for an event on 05th Feb 2019 at 11:57 Hrs when load loss of approx. 869 MW occurred in Northern Region wherein the following generators have not given the desired response:

-Palatana GTG-I -BgTPP Unit – II

And the following generators have given negative response:

-Palatana GTG-II, STG-I/II -Kopili Unit#I

-BgTPP Unit #I

In 154th OCCM, OTPC informed that it operation of plant in RGMO is very difficult and the same has been informed in earlier OCC meeting also. Further, they stated that increasing generation in fraction of second is very difficult as corresponding

amount of gas is not supplied automatically. ONGC is operating the pipeline manually and night time is even impossible.

NERLDC may please highlight the event dated 12.03.2019.

Deliberation in the Meeting:

NERLDC highlighted the event (presentation attached at **Annexure-D.4**) dated 12.03.2019. GTG 1 & STG 2 of OTPC Palatana and Unit 1 of BGTTP were found to be giving response less than the desired response, whereas, GTG 2 & STG 1 of OTPC Palatana and Unit 2 of BGTTP were found to be giving negative response. GM, NTPC informed that CMG tuning is being done by Honeywell and the subsequently errors would be rectified. Representatives from the generating utilities voiced in unison the concern that RGMO response is posing difficulties in maintaining the ZCV restrictions..

Kopili informed that for the event dated 5/2/19 since the RGMO was triggered 5min, prior to the event response in the opposite direction had started. So a negative response is noticed during the event.

The forum requested NEEPCO to give a presentation in the next OCCM on the logic of its units for RGMO along with case study for event dated 5/2/19 NHPC to give presentation on the impact of ZCV on RGMO.

The Sub-Committee noted as above.

Action: NEEPCO, NTPC, OTPC.

D.5 Assessment of TTC, TRM & ATC by SLDC on respective Inter-State Transmission Corridor

Deliberation in the meeting:

The forum requested all the SLDCs to carry out the TTC/ATC calculations and decided that SLDC Ar. Pradesh would give presentation in the next OCC.

NERLDC intimated that State-wise ATC/TTC calculated by NERLDC on behalf of SLDCs was mailed to all utilities on 09.04.19.

The Sub-Committee noted as above.

Action: all SLDCs.

D.6 Reliable power supply to Manipur system

For Ensuring reliable power supply to Manipur system, following actions were suggested by NERLDC:

- a. 132 kV Jiribam – Jiribam (MA) – Rengpang – Loktak link to be kept in loop
- b. Restoration of 132 kV Dimapur – Imphal line
- c. Upgradation of 132 kV Kohima – Karong – Imphal (MSPCL) link

In 154th OCCM MSPCL informed the Forum that they would keep in 132 kV Jiribam – Jiribam (MA) – Rengpang – Loktak lin loop after checking the phase sequence. Powergrid informed 132kV Dimapur-Imphal will be restored after June 2019 and regarding Upgradation of 132 kV Kohima – Karong – Imphal (MSPCL) link no discussion due to the absence of Nagaland personnel.

Deliberation in the meeting:

The following status was informed:-

- (a) 132 kV Jiribam – Jiribam (MA) – Rengpang – Loktak link - By April'19
- (b) Restoration of 132 kV Dimapur – Imphal line – Can be ascertained after resolve of ROW issue by Nagaland
- (c) Upgradation of 132 kV Kohima – Karong – Imphal (MSPCL) link - Upgradation of 132kV Karong-Kohima by July'19.

The Sub-Committee noted as above.

Action: MSPCL, DoP Nagaland, NERTS

D. 7 Overloading of 132kV Pare-Lekhi line:

To limit the overloading of 132kV Pare-Lekhi line, 132kV Itanagar-Lekhi line has to be kept closed. As reported by SLDC Arunachal Pradesh during real time, they are unable to close the 132kV Itanagar-Lekhi line. Status review of CT ratio of 132kV Itanagar-Lekhi (Study results enclosed as Annexure-D.10)

Deliberation in the meeting:

The issue could not be discussed due to absence of Ar. Pradesh representative.

The Sub-Committee noted as above.

D.8 First time Charging of New Elements

Proposal for furnishing technical parameters required for dynamic modelling for start-up power and first-time synchronization of generators in standard formats.

In 154th OCCM NERLDC informed that draft standard format for furnishing technical parameters required for dynamic modelling for start-up power and first-time synchronization of generators was circulated to utilities vide email. It was requested to

all utilities to give comments by 30th April'19, if any. Standard format for furnishing technical parameters required for dynamic modelling is attached as **Annexure-D.8**.

Deliberation in the meeting:

NERLDC informed that no comments received on circulated format for furnishing technical parameters required for dynamic modelling for start-up power and first-time synchronization of generators

NERLDC informed that a procedure is formulated for charging of elements owned by regional entities at ISTS nodes and the same will be circulated with minutes for comments by utilities by 30th Apr'19.

The Sub-Committee noted as above.

D.9 Furnishing of breakup of STOA sold on contingency basis:

It has been observed that BgTPP, NTPC does not send breakup of STOA sold on contingency basis in real time. It is very important information for schedule preparation in real time. In absence of that BgTPP schedule become wrong in some day. It is requested to BgTPP to look into the matter.

Deliberation in the meeting:

After detailed deliberation it was agreed that BgTPP would give Break up indicating beneficiary-wise apportionment of URS. STOA on contingency basis would be approved by NERLDC only after receipt of break-up.

The Sub-Committee noted as above.

Action: NTPC

D.10 WhatsApp Group on "NER Grid Operation"

WhatsApp Group on "NER Grid Operation" has been created for exchange of information involving members from NER SLDCs, NERLDC, NERPC, POWERGRID, STU, ISGS etc. There are about 90 members in the group as on date. Active discussion in the group helps in coordination among utilities. NERPC may formalize.

Deliberation in the meeting:

The forum formalized the group.

The Sub-Committee noted as above.

D.11 Reduction of NER-ER TTC

Reduction of NER-ER TTC for 26th Mar'19 for shutdown of 400 kV Misa-Balipara I was implemented as per D-3 confirmation. However, the shutdown was not availed in

real time. NERTS may intimate the reason for deviation from the schedule after confirmation on D-3. Utilities are requested to strictly adhere to the approved shutdown schedule after confirmation on D-3.

Deliberation in the meeting:

NERLDC informed that though the shutdown for 400kV Misa-Balipara-I was approved the same was not availed. This reduced the NER-ER TTC and affected commercially all the utilities. The forum requested NERTS to desist from such actions in future and requested all the utilities to give advance intimation for non-availing of shutdown so that there are no commercial implications.

It was agreed that utilities not availing S/D would intimate justification of same and rescheduling would only be considered in next OCC.

The Sub-Committee noted as above.

Action: NERTS, All utilities

D.12 Updating the List of Important Grid Elements of NER.

All the Utilities are requested to update the excel file by 30th April'19 circulated vide email dated 06.02.19.

The Sub-Committee approved.

D. 13 Spare of SEMs / DCDs:

Spare SEMs in stock are around 15 nos. and spare DCDs around 5 nos. as per latest information available. Considering the upcoming Transmission & Generation projects to be commissioned in next 2 years, 100 SEMs & 20 DCDs may be procured.

Deliberation in the meeting:

The Sub-Committee noted as above.

D. 14 5 min metering:

CERC Order Dated: 16th of July, 2018, on Petition No. 07/SM/2018 (Suo-Motu) in the matter of - Pilot Project on 05-Minute Scheduling, Metering, Accounting and Settlement for Thermal/Hydro, and on Hydro as Fast Response Ancillary Services (FRAS). Following are the action points –

- a. CTU to Install sixteen no. of 5-minute SEMs in NER- Eight nos. at Loktak HEP (4-main & 4-check) and Eight nos. at NTPC-BgTPP (4-main & 4-check).
- b. All future procurements of Interface Energy Meters should ideally have

recording at 5min interval and frequency resolution of 0.01 Hz. They should be capable of recording Voltage and Reactive Energy at every 5-min and should have feature of auto-time synchronization through GPS.

c. Accordingly, CTU shall facilitate the pilot project with installation of 5-minute meters at the pre-identified locations.

Accordingly CTU to arrange 16 no. of 5-Minute SEMs along with 2 no. of Compatible DCDs.

Deliberation in the meeting:

NERTS informed that as confirmed from CC (AM) till date no 5 min meters has not been procured and also there is no standard TS for procurement of the same. As presently no 5 min SEM can be procured/installed.

The Sub-Committee noted as above.

D.15 Dismantling of 132kV S/C Dimapur-Imphal Transmission Line on account of highway construction by NHIDCL at Nagaland - outage thereof.

During the deliberation of special meeting held at Imphal on 25.09.2018 in connection with dismantling of 132KV Dimapur - Imphal S/C Transmission Line of POWERGRID to facilitate construction of Dimapur-Kohima 4-lane Highway, it was discussed and decided that POWERGRID would dismantle the line in various stretches involving 32 nos. of locations to clear the front to NHIDCL for construction of the Highway. Further, POWERGRID agreed to restore the line within 31.01.2019 subject to resolve of all RoW issues in time by Nagaland State Administration immediately on occurrence.

The foundation & erection works for diversion of the line has accordingly been taken up by POWERGRID with adequate mobilization. However, Right of Way issues along the new route involving 28 nos. of locations became deterrent to the progress as those are taking considerable time to get resolved. Further, with continuous persuasion with state administration only compensation for ROW of Dimapur portion involving 15 nos. of tower could be cleared on 08.03.2019. Subsequently, POWERGRID could expedite the progress in said 15 nos. of locations.

Now, so far as Kohima portion involving 13 nos. of tower is concerned, compensation for ROW of 9 locations has been finalised by the district Administration (Kohima) on

18.03.2019 and subsequently, POWERGRID has mobilised gangs in those locations.

Thus, as on date, following critical issues are pending with state administration:

- a. Finalization of compensation of ROW for balance 4 locations in Kohoma District
- b. Finalization of compensation for Surface damage for all the new spans in Kohima District

POWERGRID is pursuing continuously with the Administration to resolve above issue so that the construction activity can be taken up subsequently. In this regard, Commissioner (Power), Nagaland has expressed concerned on the issue and communicated Commissioner, Nagaland on 11.03.2019 to finalise the land compensation issue of Kohima portion to facilitate diversion of 132kV Dimapur – Imphal Line. The copy of the letter is enclosed for your ready reference.

Under such circumstances, considering lead time required for construction after resolving ROW issues, it is envisaged that the complete diversion work of 132kV Dimapur – Imphal Line would require another 3-4 months i.e., atleast till July 2019. However, possibility of further extension of completion period exists under following conditions:

1. Non-finalization of balance compensation issues in Kohima District as stated above by Nagaland within March 2019.
2. Possible uncongenial weather condition in coming monsoon as the job already spilled over to monsoon period.

It is pertinent to mention here that considering the request of Nagaland Government, the concerned authority of the region allowed dismantling of 132kV Dimapur – Imphal Line to facilitate construction of Highway in Nagaland. However, as per practice, for any diversion work POWERGRID always first construct the diverted portion and then shifting is done to avoid outage. But, in this particular case the situation is otherwise.

Hence, considering all above stated facts, it is requested to consider the outage of 132kV Dimapur – Imphal Line under ***“Force Majeure Condition”*** till completion of restoration.

Deliberation in the meeting:

After detail deliberation, the forum agreed to consider the outage of 132kV Dimapur – Imphal Line under ***“Force Majeure Condition”*** till completion of restoration.

The Sub-Committee noted as above.

D.16 Acute Right Of Way constraints in execution of Railway diversion work of 132kV Nirjuli - Ranganadi TL

The issue of RoW constraints encountered by POWERGRID in Railways diversion work of 132KV Nirjuli -Ranganadi TL in Arunachal Pradesh was discussed in details during 19th TCC & NERPC meeting held at Guwahati on 27th & 28th Nov'2018.

As decided during the meeting, POWERGRID has already taken up the matter with Commissioner (Power), Govt. of Arunachal Pradesh & it is understood that necessary instruction has been passed on to the district Administration for early resolution of the RoW constraints.

It is pertinent to mention here that due to acute RoW issue the original route involving 3 locations was changed to another route involving 4 locations as per the advice of DC. However, as on date, POWERGRID is yet to receive clearance from AP Administration for RoW in the revised route which falls in Ambabasti village under Papumpare District. This is severely affecting the diversion work of the line as well as OPGW link establishment between Nirjuli, Lekhi (DoP, A.P.) & Ranganadi HEP under Microwave vacation project.

Deliberation in the meeting:

The issue is again referred to next TCC / NERPC meeting for further deliberation and early resolution by Arunachal Government.

The Sub-Committee noted as above.

D.17 Acute Right Of Way constraints in in faced by POWERGRID in Assam for Maintenance of Transmission Lines:

During 19th NERPC Meeting held on 28th and 29th November 2019 at Guwahati, the issue of acute ROW problem faced by POWERGRID for maintaining 800 kV HVDC, BNC-AGRA Line, 400 kV D/C Bongaigaon – Balipara – III & IV, 400 kV D/C Silchar – PK Bari – I & II Line was discussed in details.

Till now, since then, there is no improvement in ROW issues. It is to be mentioned here that \pm 800kV HVDC Line is passing through three region viz. NER, ER & NR and so, if any one Region takes shut down; other two Regions get opportunity shut down for maintenance of the line. Thus, there are many opportunity shut down available in

this line but unfortunately, NER is not able to avail such opportunity shut down apart from its own approved shut down because of persisting ROW issues. The matter needs to be resolved on priority by escalating at highest administrative authority so that such important lines can be made defect free by carrying out regular maintenance by POWERGRID.

Deliberation in the meeting:

The issue is again referred to next TCC / NERPC meeting for further deliberation and early resolution by Assam Government.

The Sub-Committee noted as above.

D.18 Circuit Breaker between Air Insulated Substation (AIS) and Gas Insulated Substation (GIS):

During 152nd OCCM (Refer MOM Item No. D.29), NERLDC proposed to install circuit breaker between AIS and GIS so that integration of GIS with AIS and maintenance of AIS bus could be done without taking the shutdown of the GIS and vice-versa in all the hybrid substations of NER.

Accordingly, the matter was referred to CTU for necessary review. After detail examination by CTU and POWERGRID, CC Engineering Department it was conveyed that construction of 400kV Bus Sectionalizer at this juncture is not possible due to severe space constrain and other technical issues. Further, it is suggested that for maintenance of AIS bus, jumpers interconnection between AIS & GIS may be removed.

Deliberation in the meeting:

Sr. GM(AM), NERTS informed the forum that the matter was referred to CTU for necessary review. After detail examination by CTU and POWERGRID, CC Engineering Department it was conveyed that construction of 400kV Bus Sectionalizer at this juncture is not possible due to severe space constraint and other technical issues.

CGM, NERLDC opined to refer the issue to next NERSCT.

The Sub-Committee noted as above.

D.19 Conversion of 132kV Badarpur, 132kV Khliehriat, 132/33kV Nirjuli and 132kV Imphal Station from Single Main Transfer Scheme to Double Main Transfer Scheme on GIS on completion of 25 years age:

During 16th NERPC and 6th SCM Meeting, approval was accorded for up-gradation of Bus Bar Scheme from Single Main Transfer to Double Main for 132kV Haflong, 132kV Jiribam, 132kV Kumarghat and 132kV Aizawl Sub Station on completion of 25 Years age considering the fact that Single Main and Transfer Scheme offers minimum reliability. Due to space constraint the conversion / up-gradation was approved on GIS from AIS.

Now the existing Bus Bar arrangement of 132kV Badarpur, 132kV Khliehriat, 132/33kV Nirjuli and 132kV Imphal Station is also Single Main and Transfer Scheme. These stations are going to complete 25 Years age during current tariff block 2019-24. Hence, in line with earlier approval of 132kV Haflong, 132kV Jiribam, 132kV Kumarghat and 132kV Aizawl Sub Station, it is proposed to convert the existing Single Main Transfer Scheme of 132kV Badarpur, 132kV Khliehriat 132/33kV Nirjuli and 132kV Imphal Station to Double Main and Transfer on completion of 25 Years. Further, the 132kV Badarpur Sub Station is located near a cement factory and there are frequent deposits on the exposed AIS equipments which is creating difficulties in maintenance. Hence it is proposed to upgrade Bus Scheme on GIS. However for the other station viz. 132kV Khliehriat, 132/33kV Nirjuli and 132kV Imphal Sub Station upgradation is proposed preferably by Bus Sectionalisation on AIS depending on layout or alternatively on GIS if layout does not permit Bus Sectionalisation. The tentative expenditure considering each station to be Rs. 30.00 Crores is Rs. 120.00 Crores.

Deliberation in the meeting:

The forum approved in-principle and recommended for TCC/RPC and subsequent NERSCT approval.

The Sub-Committee noted as above.

Action: NERPC/NERTS

D.20 Up-gradation of 220/132kV Salakati Sub-station from conventional to SAS on completion of 25 years age and capitalization during tariff block (2019-2024)

During 16TH TCC & 16th NERPC Meeting (MOM Item No. A.9) approval was accorded for up-gradation of 220/132kV Salakati Sub Station by POWERGRID on completion of 25 Years. The activities covered under upgradation in Tariff Block 2014-19 was replacement of all old equipments and up-gradation of the Substation from conventional to SAS with tentative expenditure of Rs 10.00 to 12.00 Crores under PoC Mechanism.

Now, the up-gradation tender is in final stage and the job will be taken up in tariff block 2019-24.

This is for kind information to forum for onwards information to next 20th TCC & 20th NERPC Meeting.

ADDITIONAL AGENDA ITEMS

D.21 Cost Escalation for installation of Line Reactor at Kathalguri

The 11th NERPC had approved for installation of 20MVAR Line Reactor at Kathalguri(AGBPP) by POWERGRID for an amount of ₹ 4.444Crores. However the installation was delayed and cost increased to ₹ 5, 73, 29,819.00

Deliberation in the meeting:

The forum requested NEEPCO to release the additional payment and assured the matter would be placed before the next TCC/RPC for post-facto approval.

The Sub-Committee noted as above.

Action: NEEPCO/NERPC.

D.22 Commissioning of BgTPP Unit#III

Director, NERPC informed that in violation of the commissioning procedures (decided in NERPC forum) for new units, BgTPP Unit #III was declared CoD w.e.f.00:00hrs of 26.03.2019. This was done due to targets set by the MoP and express requests of NTPC Management. He once again reiterated that any new units prior to commissioning must give advance notice of seven days to all the beneficiaries and witnessing of the CoD is also a part and parcel of the procedure.

GM(SO-I), NERLDC informed that immediately after CoD Unit #III was taken under RSD wef 0000 Hrs of 26.03.2019 as there was no requisition. Subsequently, when the unit was scheduled wef 0000 Hrs of 27.03.2019, it failed to deliver and DC was reduced for BgTPP. TSECL representative expressed concern over non-performance of the unit on the first instant after COD. The forum requested NTPC to clarify.

GM(Plant), NTPC at the very outset apologized for the manner of declaring CoD. He informed that on 27.03.2019 it was noticed that there is DC Seal Oil Pump failure due to which Stock did not close. Since DC is emergency, the problem required immediate attention. After draining out the oil, barring gear has to be stopped and temperature lowered. This procedure requires atleast 3 to 4 days. So the machine was returned into service only on 02.04.2019 after completion of all works.

Forum expressed concern over the entire process right from declaration of COD to the failure of the unit just after COD.

After deliberation, COD wef 0000 Hrs of 26.03.2019. However, NTPC was advised to follow the procedure in future.

The Sub-Committee noted as above.

D.23 Furnishing Technical and Commercial data for computation of PoC Charges and Losses for July to September'19 (Q2 of 2019-20):

All the power utilities are requested to furnish Technical and Commercial data for computation of PoC Charges and Losses for July to September'19 (Q2 of 2019-20) by 15th April'19.

The Sub-Committee noted as above.

D.24 Disturbance of CEA category-V in NER Grid on 3rd Apr'19

Tripura Power System except P.K Bari area, Bangladesh (South Comilla load) Power System, Palatana Units and AGTCCPP Units were connected with rest of NER Grid through 400 kV Silchar – Palatana 2 line, 132 kV AGTCCPP - Kumarghat line & 132 kV P K Bari-Kamalpur line.

(400 kV Silchar - Palatana 1 line was under emergency shutdown for bamboo clearance, 132 kV Baramura – Gamaitilla line was under shutdown and 132 kV Ambassa – Kamalpur line was kept open to avoid over loading).

Following elements tripped subsequent to tripping of 400 kV Silchar – Palatana-2 line at 16:01 Hrs:

- a. 400/132 kV, 125 MVA, ICT-1 & 2 at Palatana
- b. 132 kV Silchar – Srikona-1 line & 132 kV Badarpur – Panchgram Line
- c. Monarchak GTG & STG
- d. Rokhia Unit-8
- e. Baramura Unit-5
- f. AGTCCPP Unit – 1, 2 & STG-1
- g. 132 kV PK Bari - Kamalpur line
- h. 132 kV AGTCCPP – Kumarghat line

Due to tripping of these elements, Tripura Power System, Bangladesh (along with South Comilla load) Power System, Palatana Generation, AGTCCPP Generation were separated from rest of NER Grid at 16:02:45 Hrs (As per Agartala PMU) and subsequently collapsed due to no source in the system.

Antecedent Regional Demand: 1649 MW

Antecedent Regional Generation: 1897 MW

Load Loss: Tripura Power System- 115 MW & Comilla Load: 121 MW

Generation Loss: 823 MW

(Tripura Generation including Monarchak: 101 MW, AGTCCPP: 57 MW, Palatana: 665 MW)

CEA Category: GD-V

Deliberation in the meeting:

NERLDC made a brief presentation on the GD-V (attached at Annexure-D.24) and following questions emerged:

- Non-synchronisation of SOE, DR, PMU timings resulting difficulty of proper analysis.
- Non-submission of DR data by utilities.
- Unwanted tripping of generators like Monarchak, AGTCCPP, Baramura, Rokhia after SPS operation.
- Mid span failure of Palatana-Silchar line at SIL loading.
- Partial operation of SPS-1
- Loading limit of PK Bari-Dhalabil line to be specified.
- NERLDC to intimate all SLDCs regarding any emergency S/D.

It was agreed that a meeting would be held on 02.05.2019 at Agartala to discuss about the GD.

All utilities would furnish related data by 20.04.2019.

The Sub-Committee noted as above.

Action: NERPC.

D.25 Issues regarding Billing of SEMs, DCDs

NERTS requested all the state utilities to furnish GST certificate and address proof of respective customers so that the requisite template for creation of new vendor can be filled up and forwarded to CC-ERP.

The Sub-Committee noted as above.

Action: All state utilities

D.26 Procurement of laptops for downloading of DR,EL for state utilities

NERPC informed that it has been brought to notice from constituents that there is a shortage of protection license along with laptops for downloading and uploading

DR/EL files & tripping incidence reports in PDMS. This is hampering timely submission of DR/EL analysis reports to NERLDC. The forum decided that procurement of additional laptops with PSCT license under PSDF quantity variation of PDMS project shall be requested.

The Sub-Committee noted as above.

Action: NERPC

D.27 Open Cycle Certification for generators

Director, NERPC suggested that for Open Cycle Certification similar procedure can be followed. The forum agreed unanimously and requested NEEPCO to submit OC data to NERLDC monthly for verification.

The Sub-Committee noted as above.

Action: NEEPCO

D.28 Issuance of weekly DSM accounts by NERPC

Director NERPC intimated that work on preparation of pending DSM accounts since January' 19 was under progress with the cooperation of NERLDC. He proposed formation of a small group comprising of NERPC, NERLDC, States & Generators who would sit together to streamline the process to enable early issuance of the accounts. Accordingly, it was agreed that meeting of the group would be convened at Guwahati on 08-05-2019/09-05-2019.

Members of the group would be:

1. Farooq Iqbal, NERPC
2. Manas Protim Nath, NERLDC
3. K. Stella, MSPCL
4. Representative from Meghalaya
5. Representative from NEEPCO
6. Representative from NTPC

Date & Venue of next OCC meeting

It is proposed to hold the 156th OCC meeting of NERPC on second week of May, 2019. However, the exact date and venue will be intimated in due course.

The meeting ended with thanks to the Chair.

Annexure-I

List of Participants in the 155th OCC Meeting held on 10th April, 2019

SN	Name & Designation	Organization	Contact No.
	No Representatives	Ar. Pradesh	-
1.	Sh. Dipesh Ch. Das, AGM (LDC)	Assam	09954110254
2.	Sh. N. Hazarika, AGM, HQ	Assam	09435386310
3.	Sh. Pintu Dekaraja, AGM (TRC)	Assam	09401516094
4.	Sh. Prantik Pran Saikia, Dy. Manager (SLDC)	Assam	09954287481
5.	Th. Sushanta, DM, MSPCL	Manipur	09862448363
6.	Sh. M. Romeo, DM, MSPCL	Manipur	09012657280
7.	Sh. W. Khyriem, EE, GSPD	Meghalaya	09856007107
8.	Sh. D. Marsharing, AE, SLDC	Meghalaya	-
9.	Sh. T. Gidon, EE, SLDC	Meghalaya	09774479956
10.	Sh. R. Khongmalai, AE, MRT, MePTCL	Meghalaya	-
	No Representatives	Mizoram	-
	No Representatives	Nagaland	-
11.	Sh. Debabrata Pal, Sr. Manager (Comml.)	Tripura	09436500244
12.	Sh. Joypal Roy, Sr. Manager (E/M)	NEEPCO	09435577726
13.	Sh. B.K. Chakraborty, DGM (E)	NEEPCO	09436309730
14.	Sh. Ashim Kumar Sarmah, Dy. Mgr	NEEPCO	09435078860
15.	Sh. M.K. Ramesh, GM (SL)	NERLDC	09449599174
16.	Sh. V. Suresh, CGM	NERLDC	09449599156
17.	Sh. R. Sutradhar , DGM (SO-I)	NERLDC	09436302714
18.	Sh. Sourav Mandal, Dy. Manager (SO-I)	NERLDC	09402102354
19.	Sh. Jerin Jacob, Asst. Manager (SO-II)	NERLDC	09602120113
20.	Sh. Subhra Ghosh, Asst. Engr. Trainee (SO-I)	NERLDC	08415857079
21.	Sh. Keshab Borah, Engineer	NERLDC	07002323608
22.	Sh. Pranjal Borkataki, Engineer	NERLDC	09402196313
23.	Sh. Ankit Jain, Manager	NERLDC	09436335381
24.	Sh. P. Kanungo, Sr. GM (AM)	PGCIL	09436302823

25.	Sh. N. Yugandhar, Sr. Manager (E/M)	NHPC	09800003819
26.	Sh. N.K. Gupta, Sr. Manager (O)	OTPC	09774233427
27.	Sh. Ramakanta Panda, GM (O)	NTPC	09650991355
28.	Sh. B. Choudhury, AGM (EEMG)	NTPC	09435503167
29.	Sh. P.K. Mishra, Member secretary	NERPC	09968380242
30.	Sh. B. Lyngkhoi, Director (O&P)	NERPC	09436163419
31.	Sh. S. Mukherjee, AD	NERPC	08794277306



उ.पू.क्षे गिड प्रदर्शन

NER GRID PERFORMANCE

For the year 2018-2019

North Eastern Regional Load Despatch Centre

POSOCO, Shillong

ZERO CROSSING VIOLATION – NER STATES

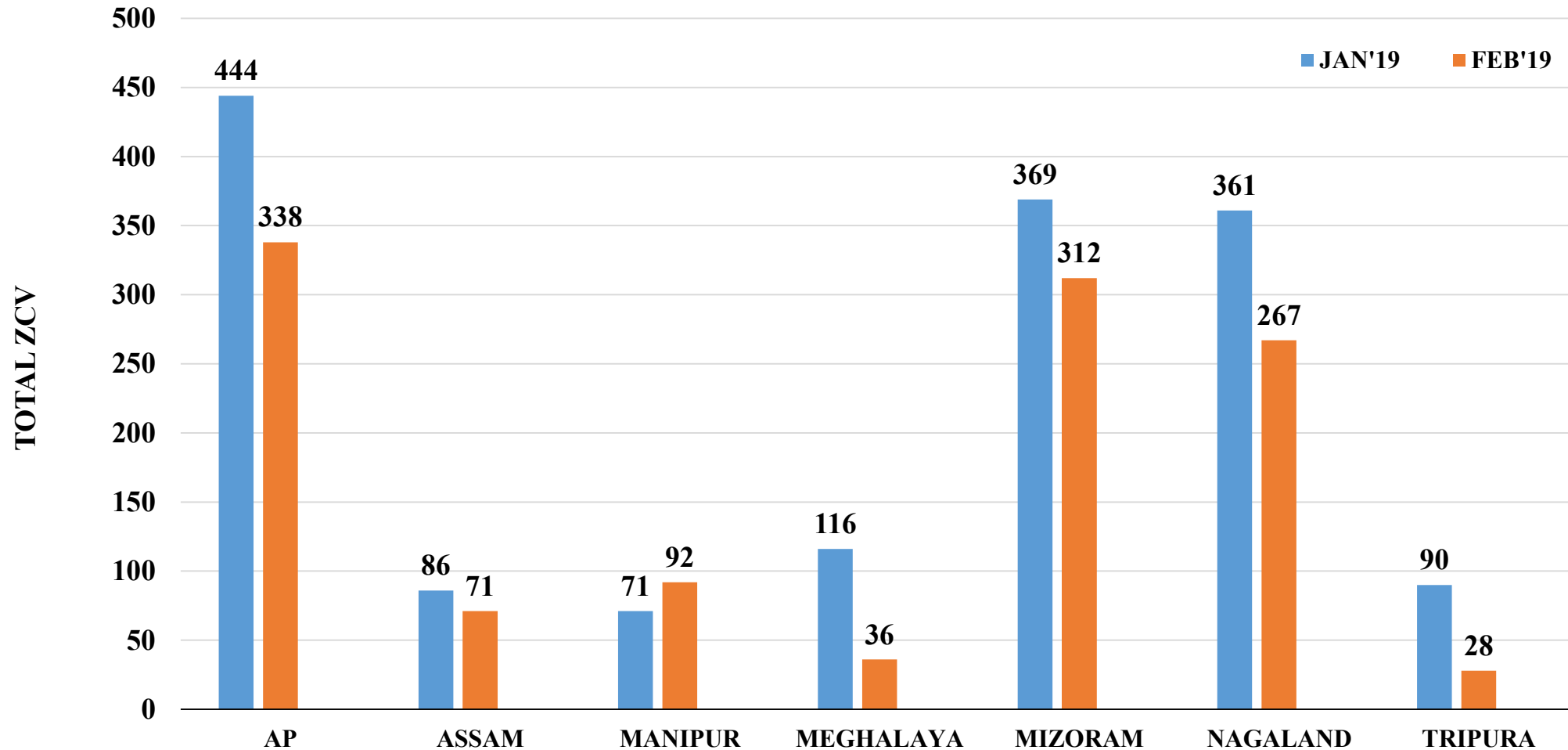

Ar. Pradesh, Mizoram and Nagaland need to take urgent measures to control ZCV and adhere to grid discipline.

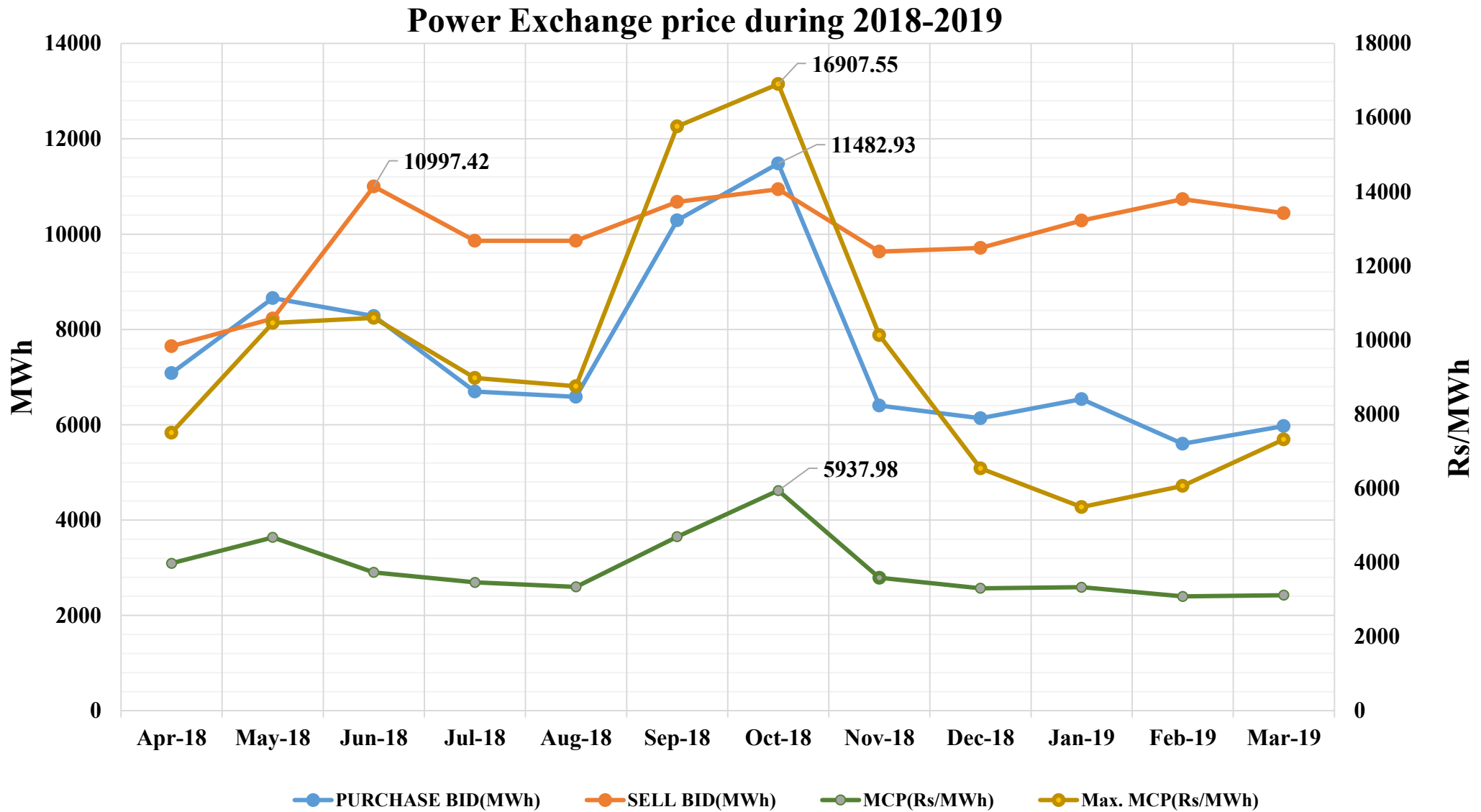

DSM is linked to Power exchange price (ACP). States need to look into and analyse the same.

Line Tripping Details during 2018-2019

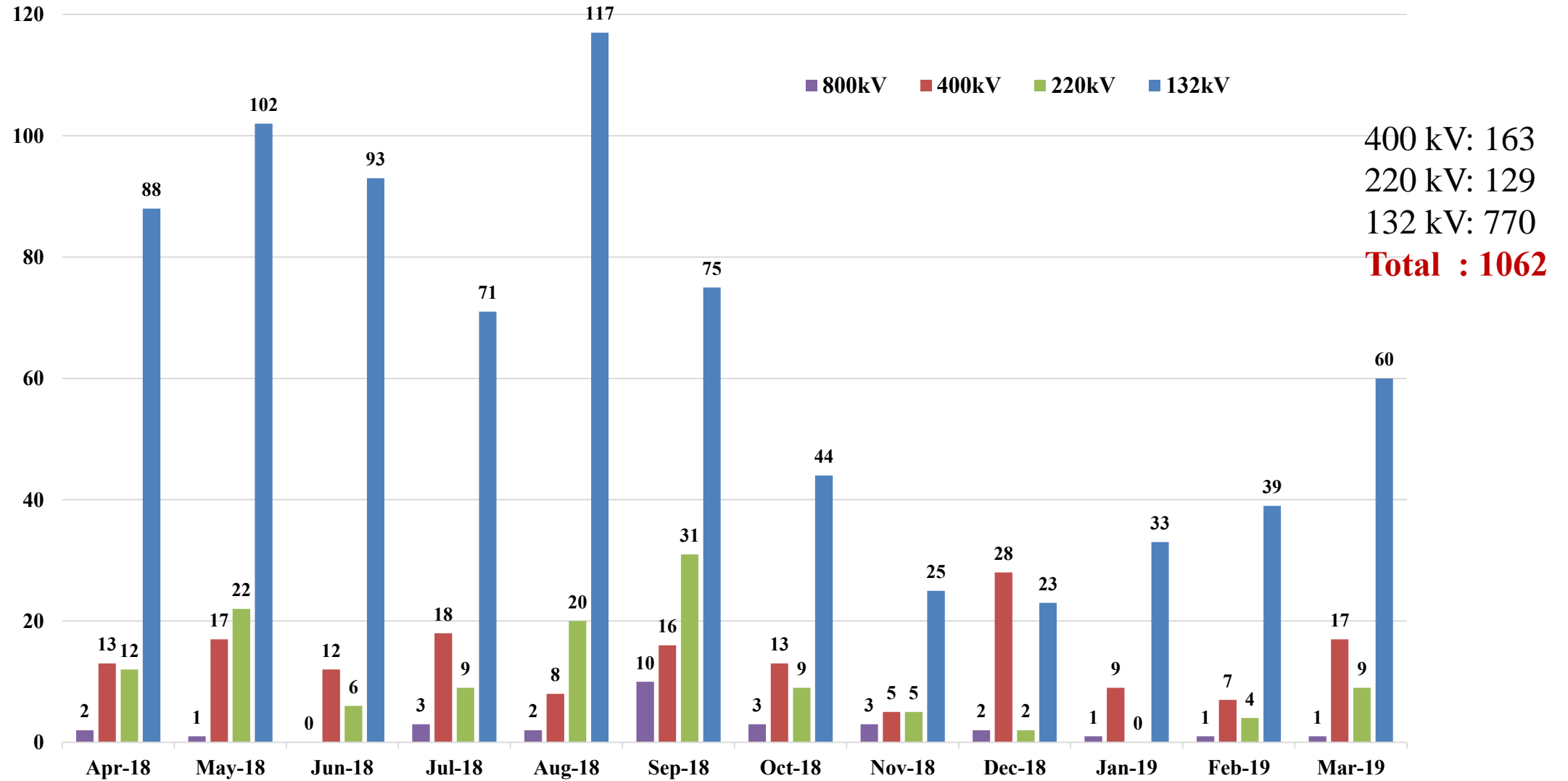

Line tripping during the years touched 1000, need to take measures to arrest.

Grid disturbances and Grid incidence during 2017-2018

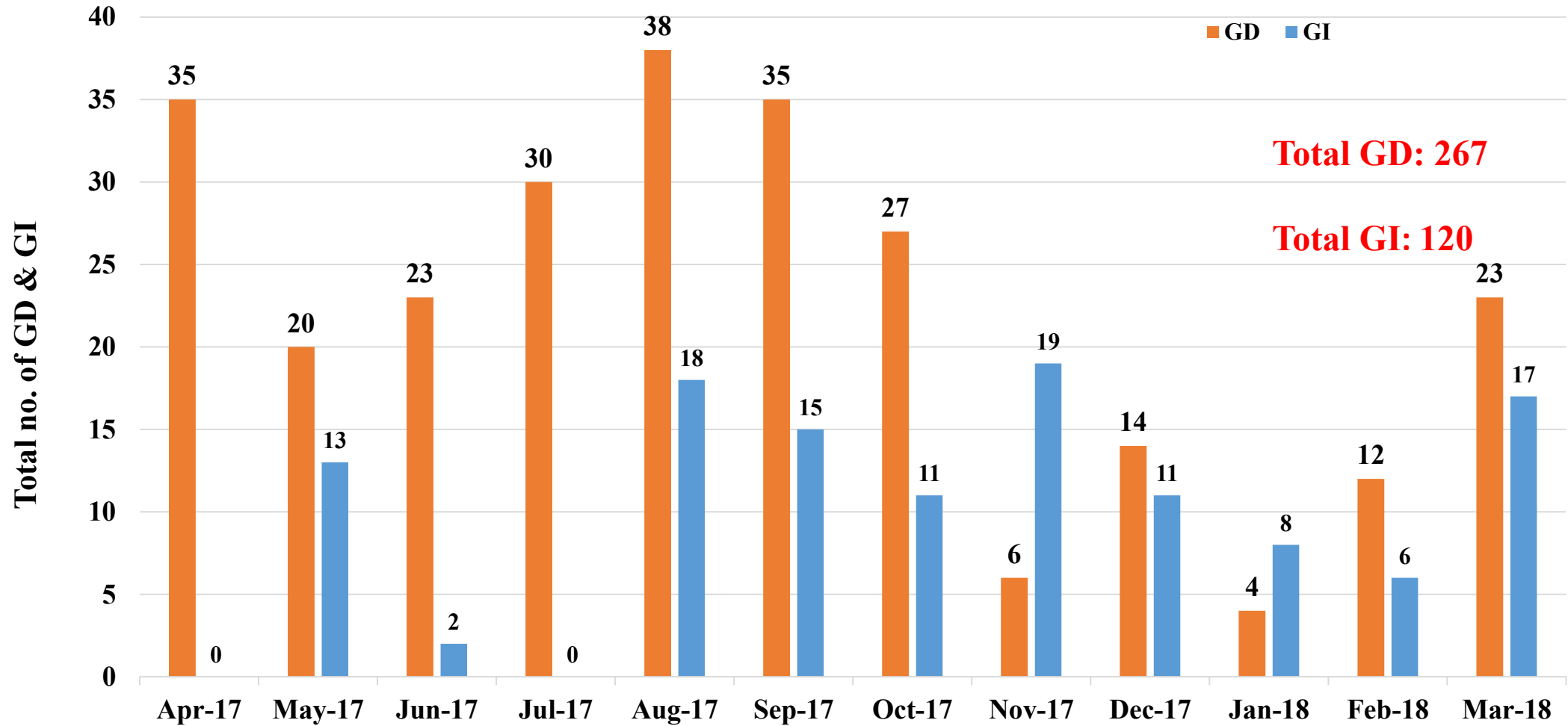

Grid disturbances, Grid Incidences in large numbers.

Grid Disturbances and Grid Incidence during 2018-2019

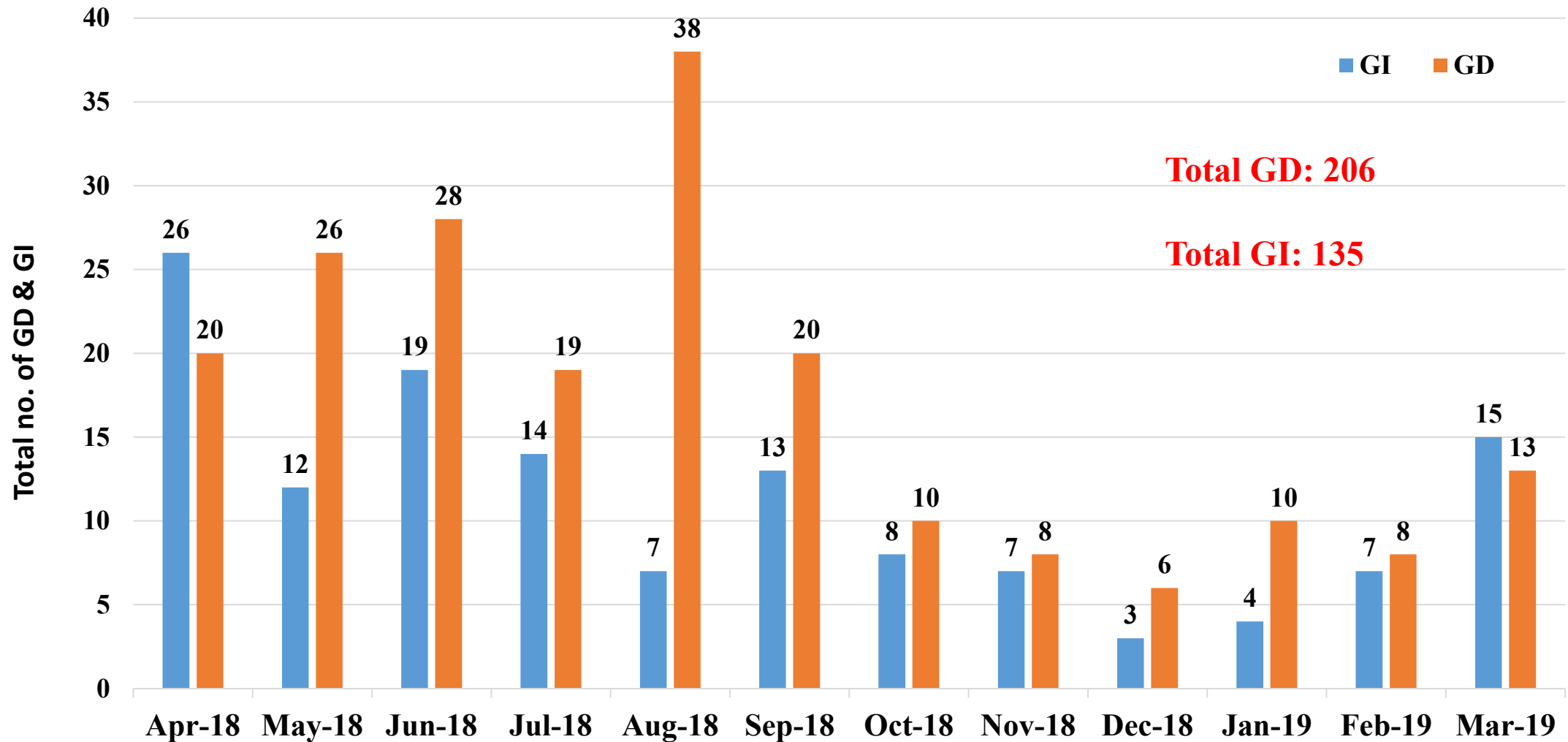

Grid incidences more than previous year.

Average Frequency 2018-19

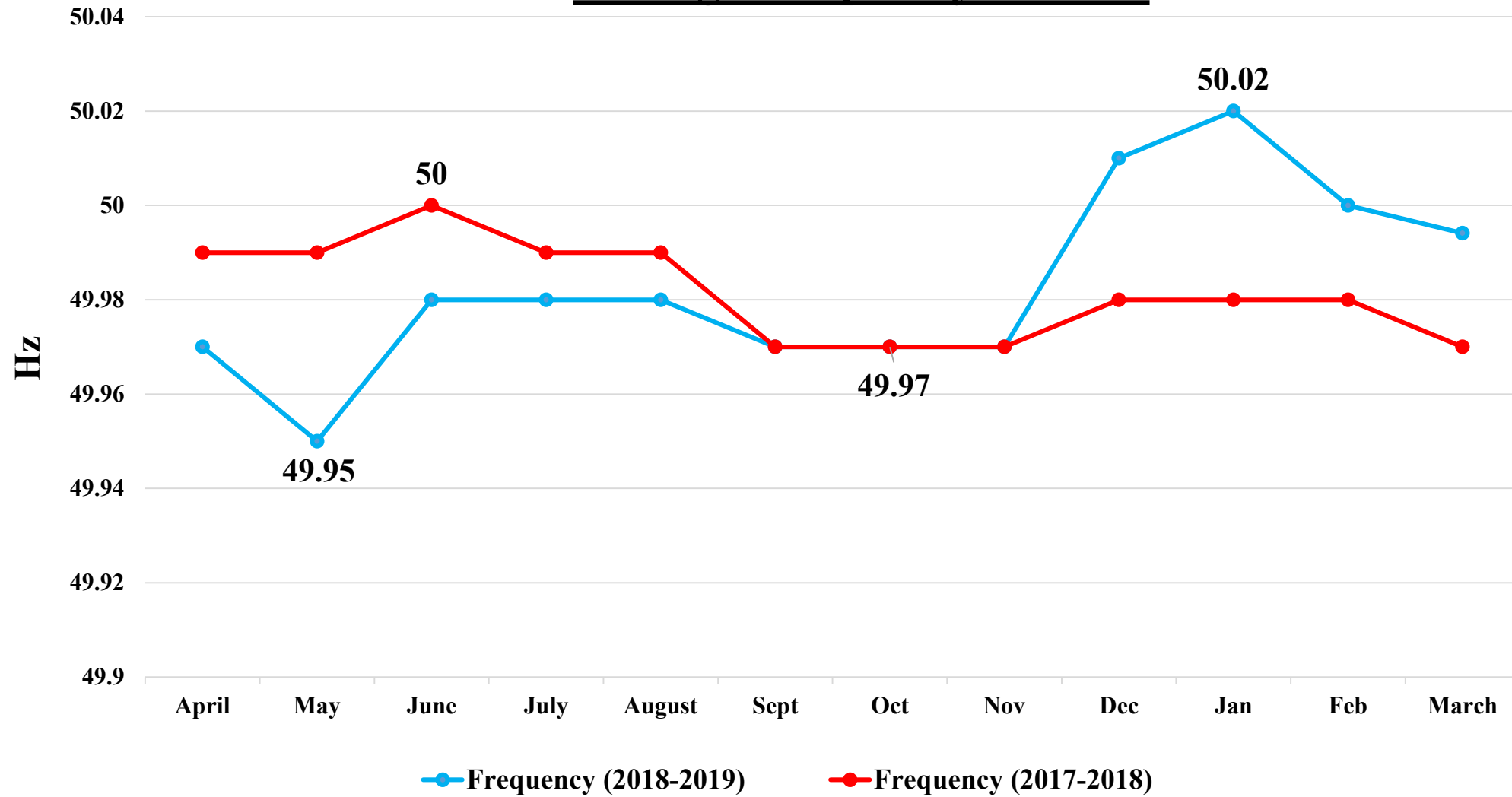

High frequency after DSM amendment, ZCV.

Energy met and Maximum demand met during 2017-18 & 2018-19

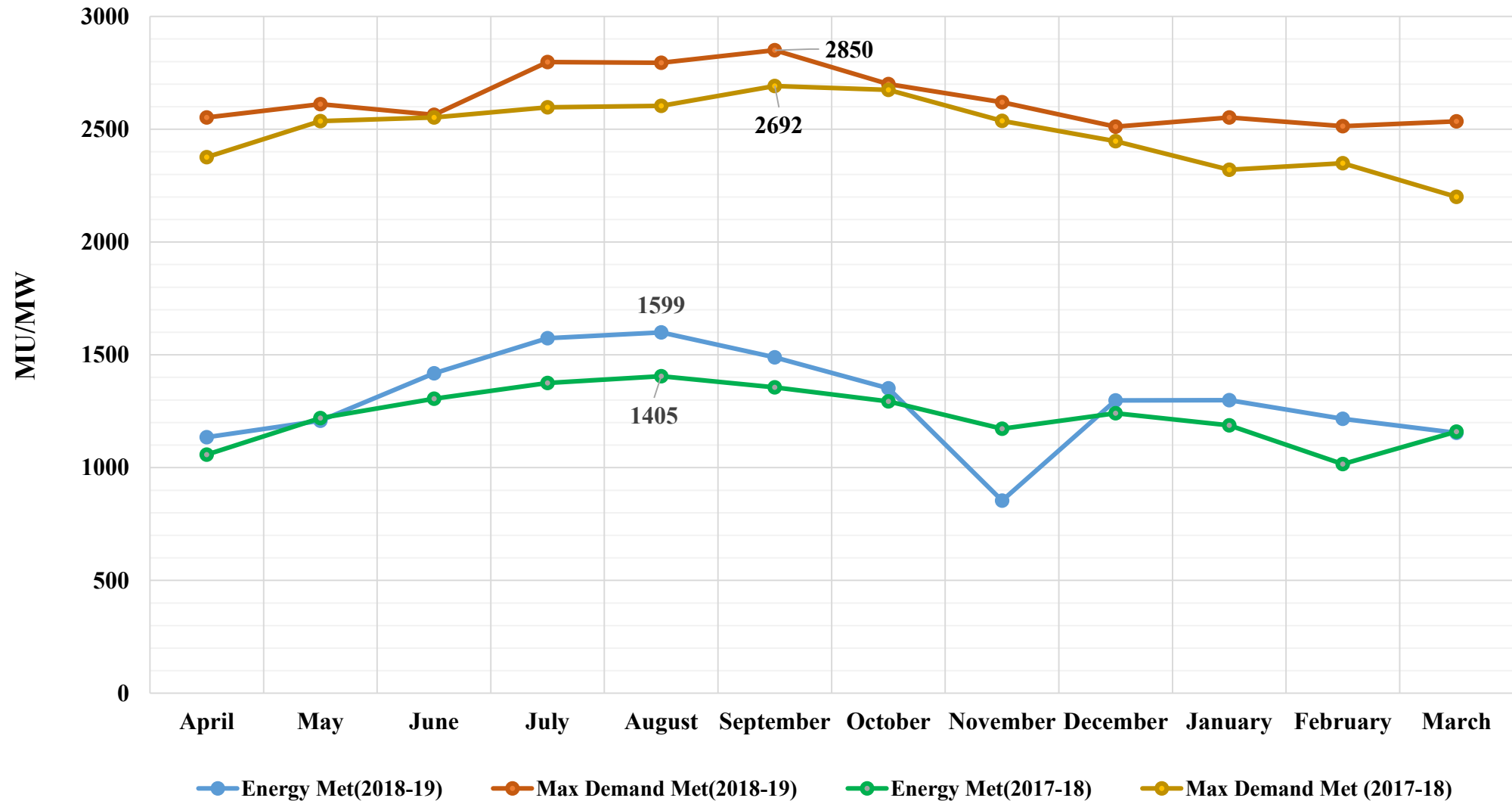

No growth, stagnant both in terms of MW and Energy.

Number of 400 kV line openings due to Over-voltage during 2018-2019

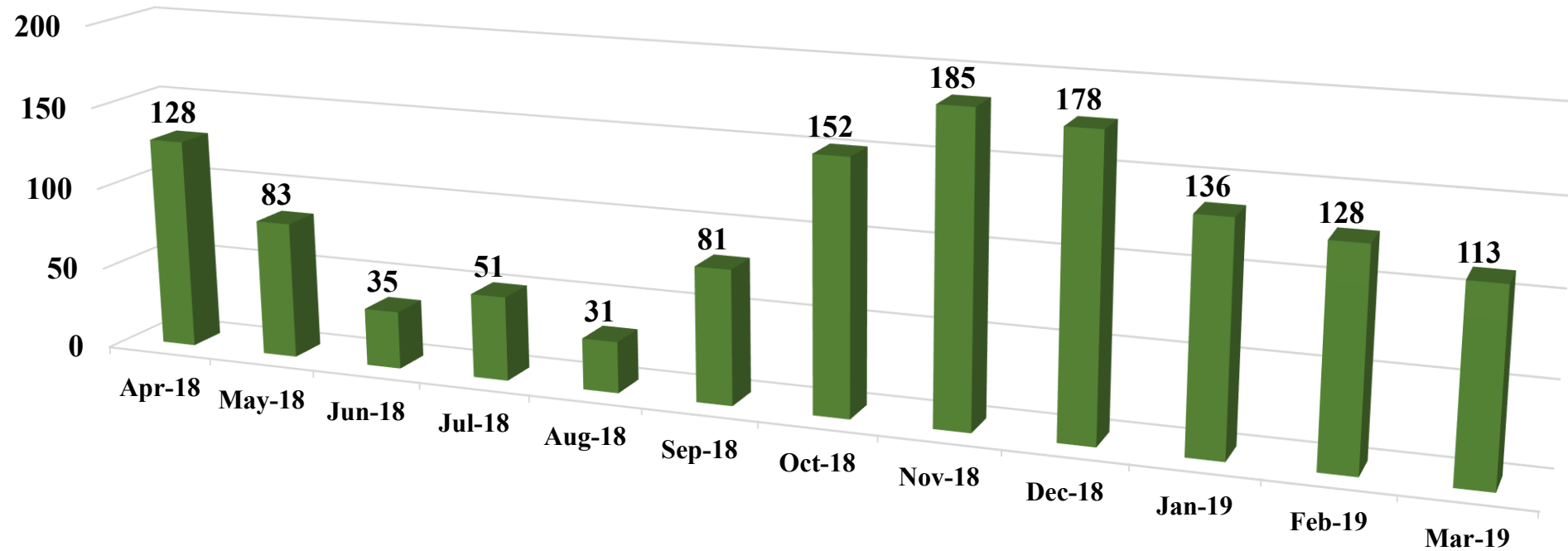

More line openings during lean hydro, maintenance of reactors to be planned accordingly.

No. of opening of 400 kV BNC-Ranganadi Circuit I & II during 2018-19

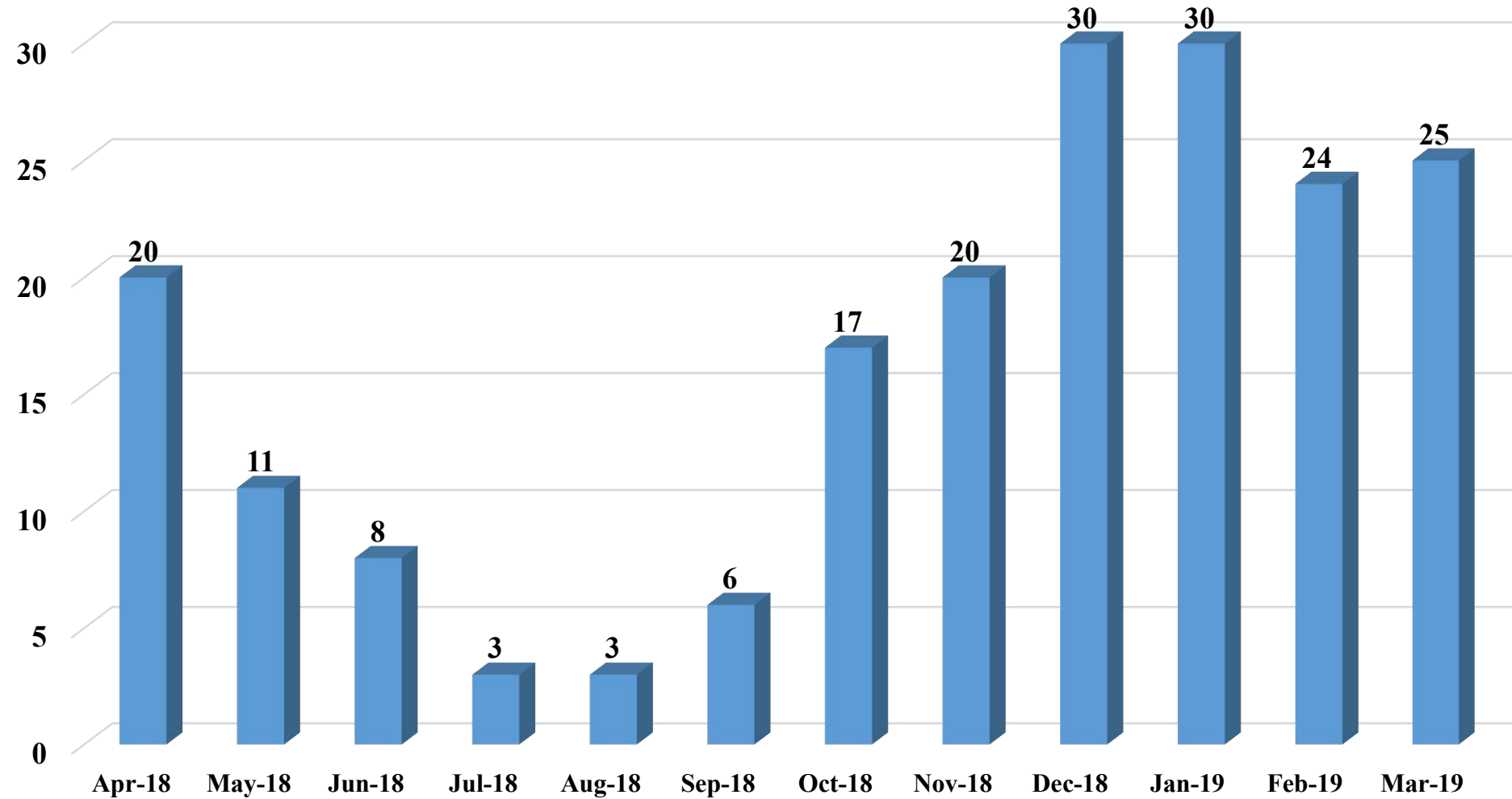

Large no. of openings of BNC-Ranganadi emphasises need of RHEP synchronous condenser operation.

Total Approved Shutdown during 2018-2019

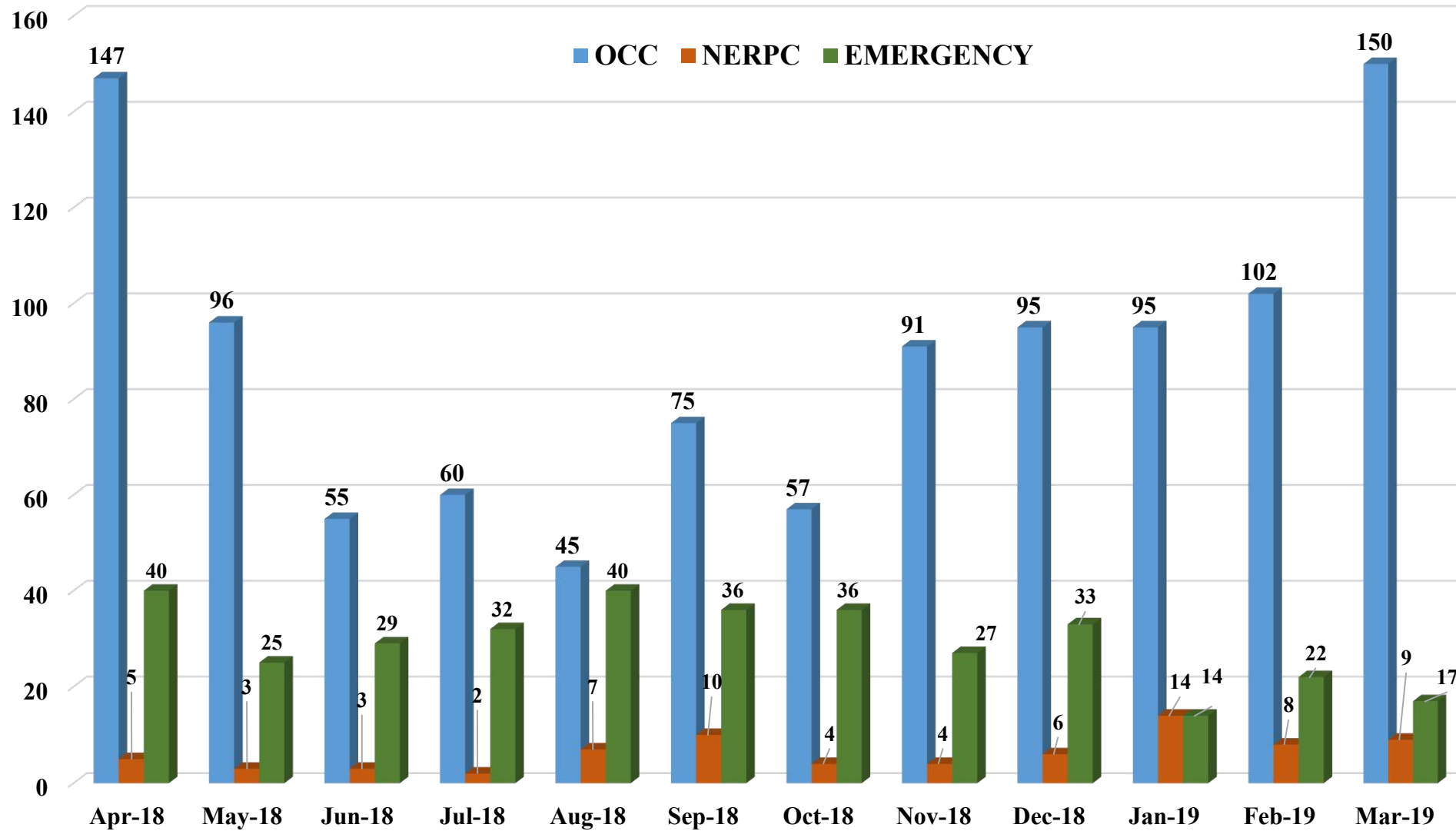

OCC: 1068
 NERPC: 75
 EMER: 351
Total: 1494

Handling and managing large numbers of S/D is a challenge.

Emergency shutdown(%) of OCC Approved

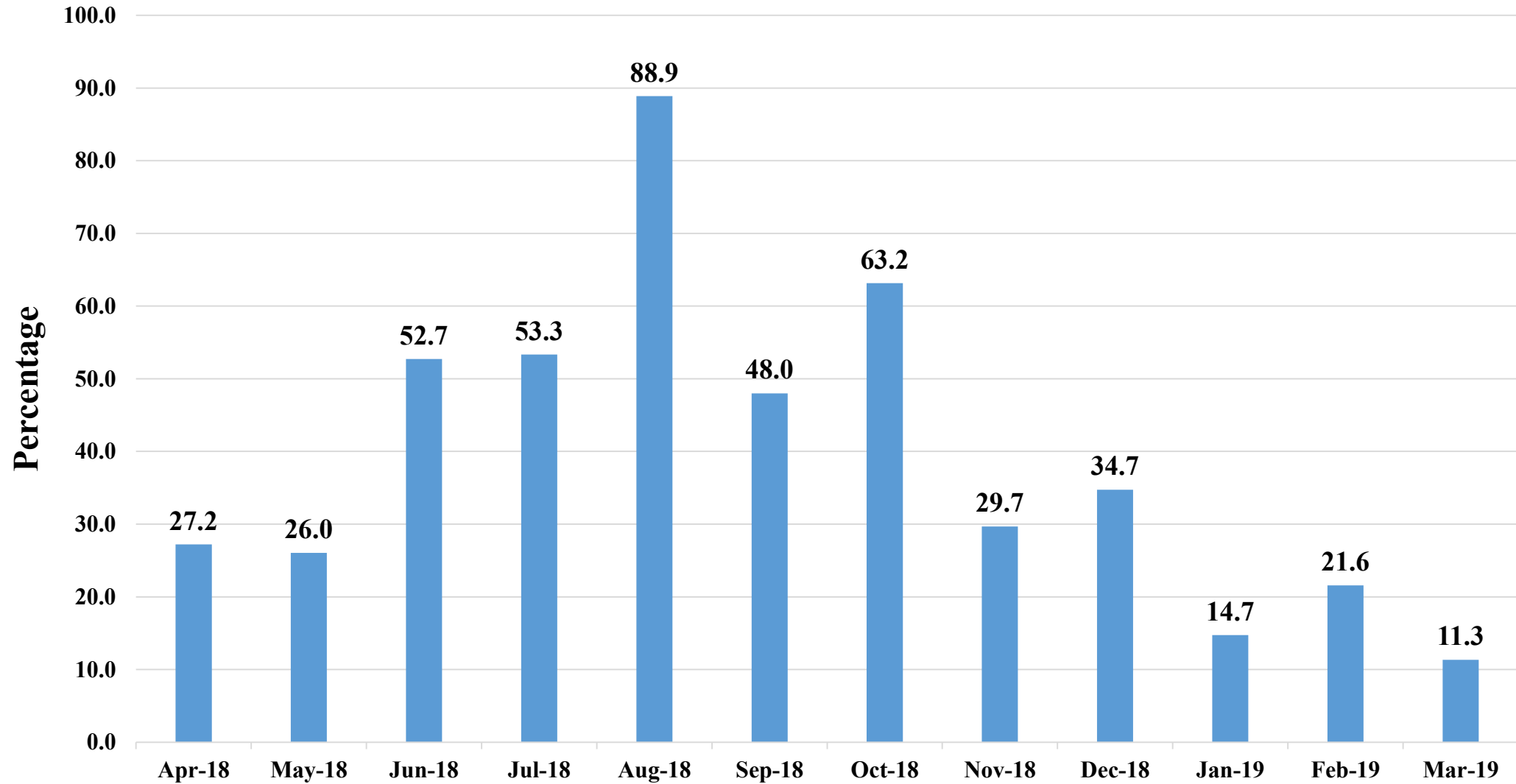

Emergency shutdown has to be minimised.

Approved shutdown Vs Aailed shutdown

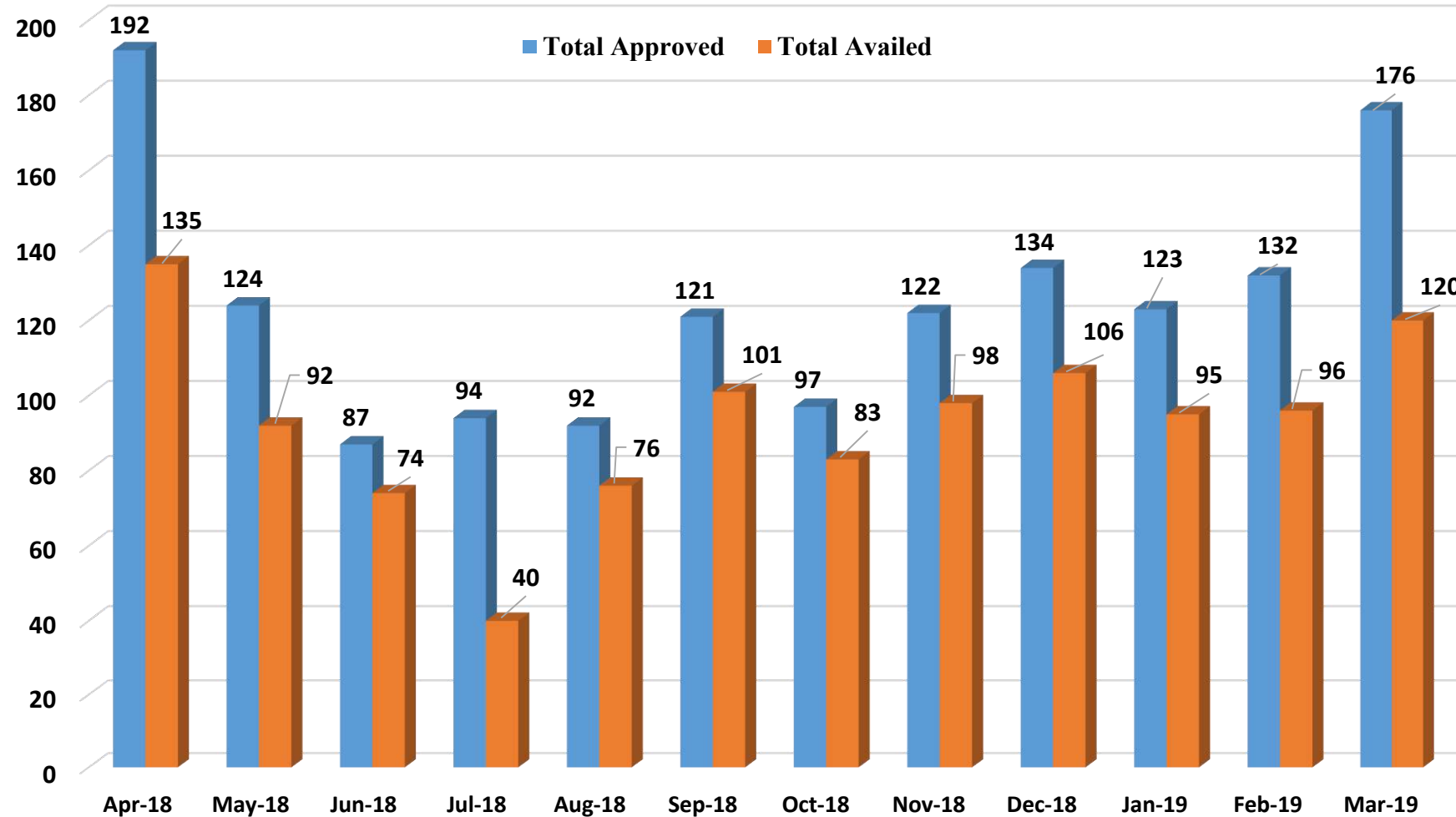

App: 1494
Avail: 1116

Substantial number of approved shutdowns are not aailed.

Availed shutdown (%) of Approved shutdown

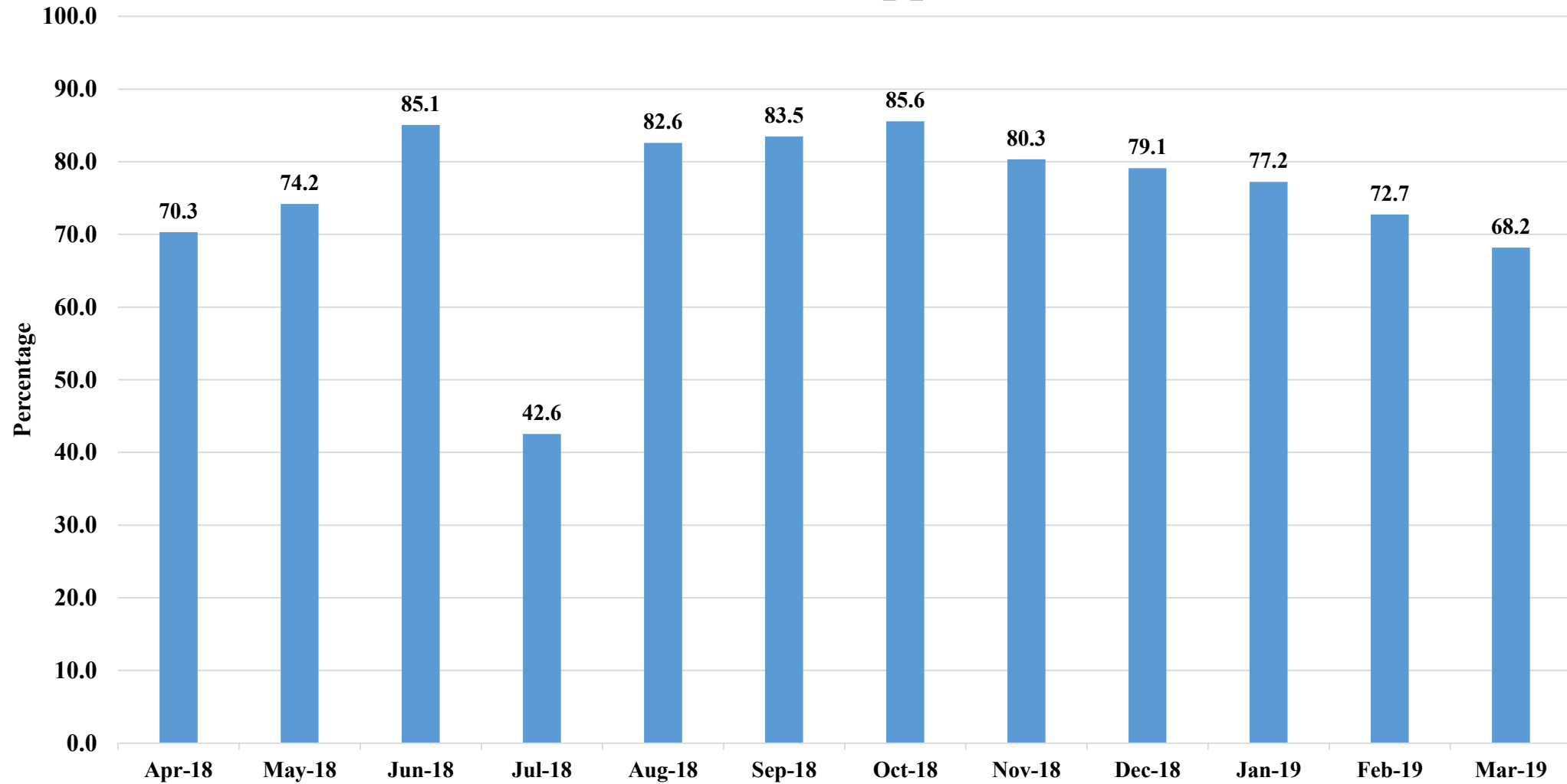

On an average 30% of approved is not availed creating problems in coordination.

New elements during 2018-19.

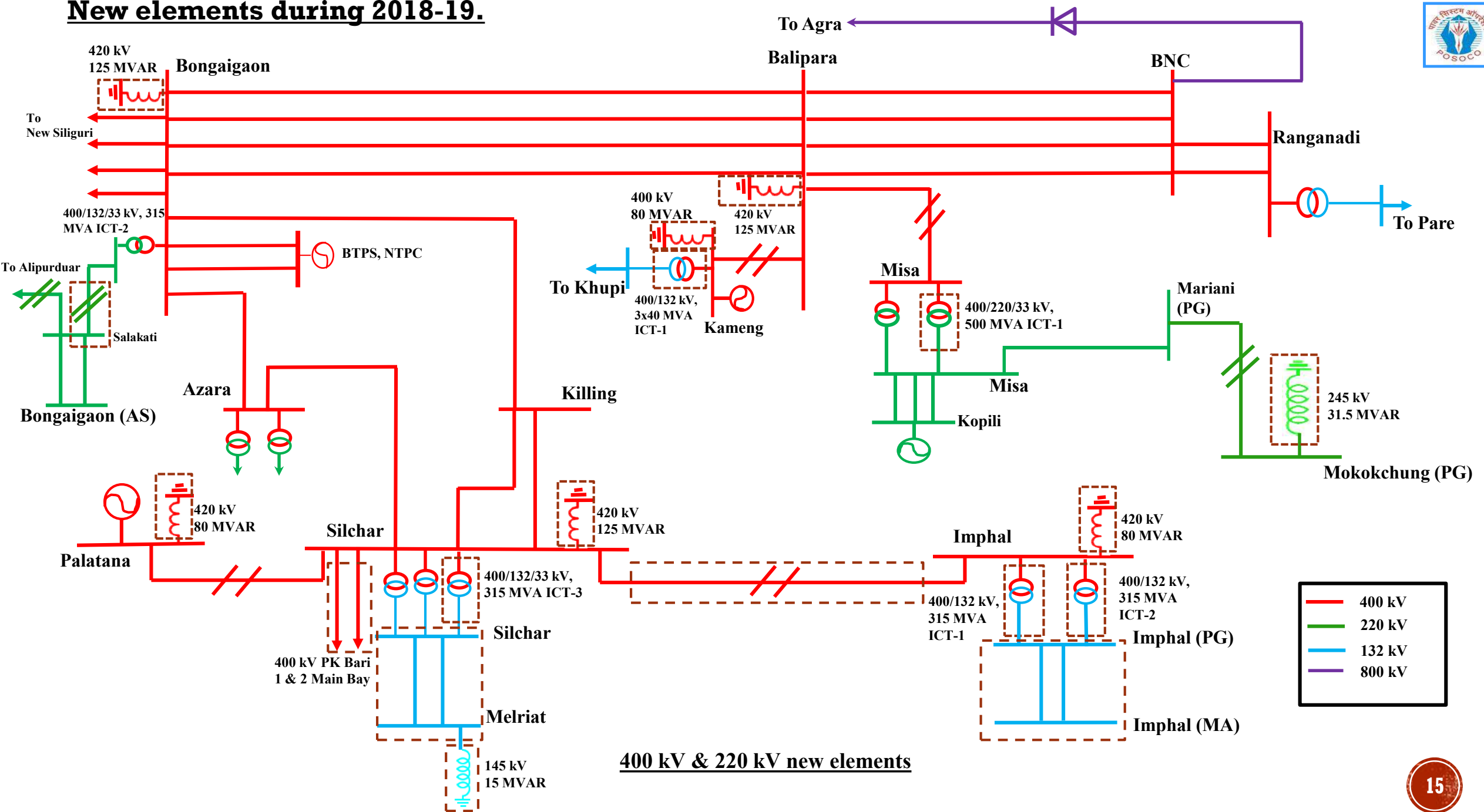

—	400 kV
—	220 kV
—	132 kV
—	800 kV

New elements during 2018-19.

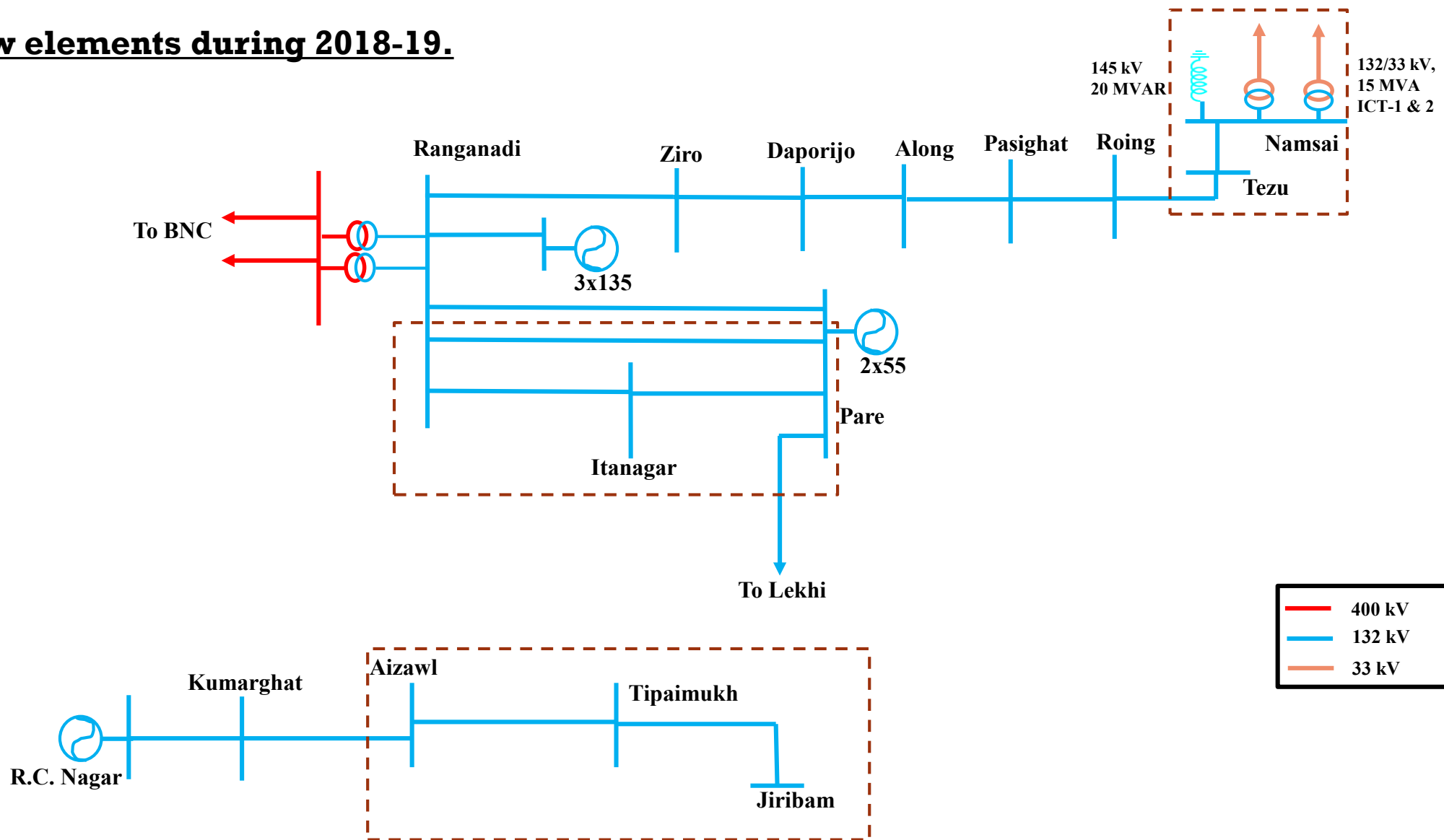



BGTPP BUS1 VOLTAGE VS GENERATOR TRANSFORMER1 MVAR

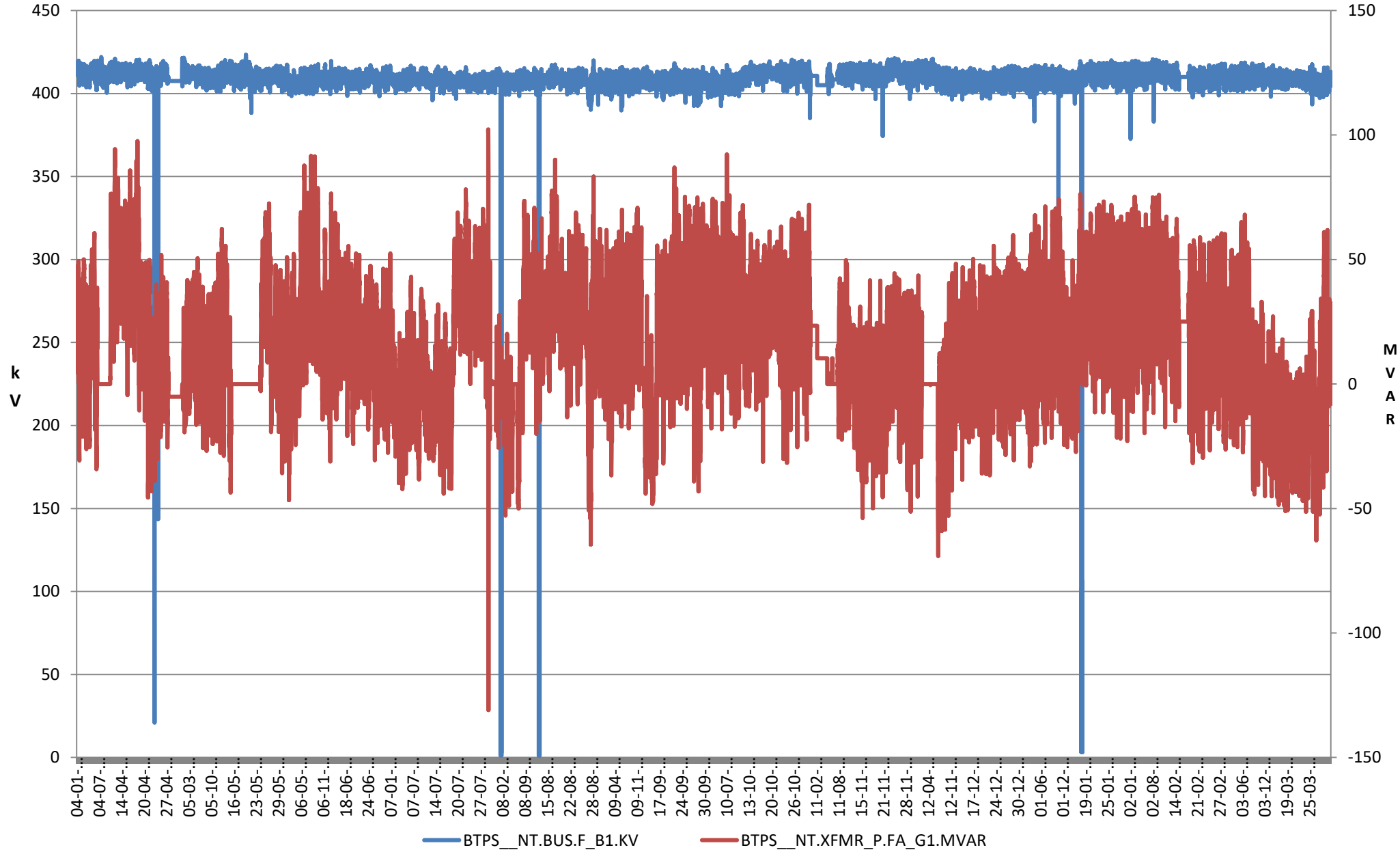

BgTTP
response is
satisfactory

BGTPP BUS2 VOLTAGE VS GENERATOR TRANSFORMER2 MVAR

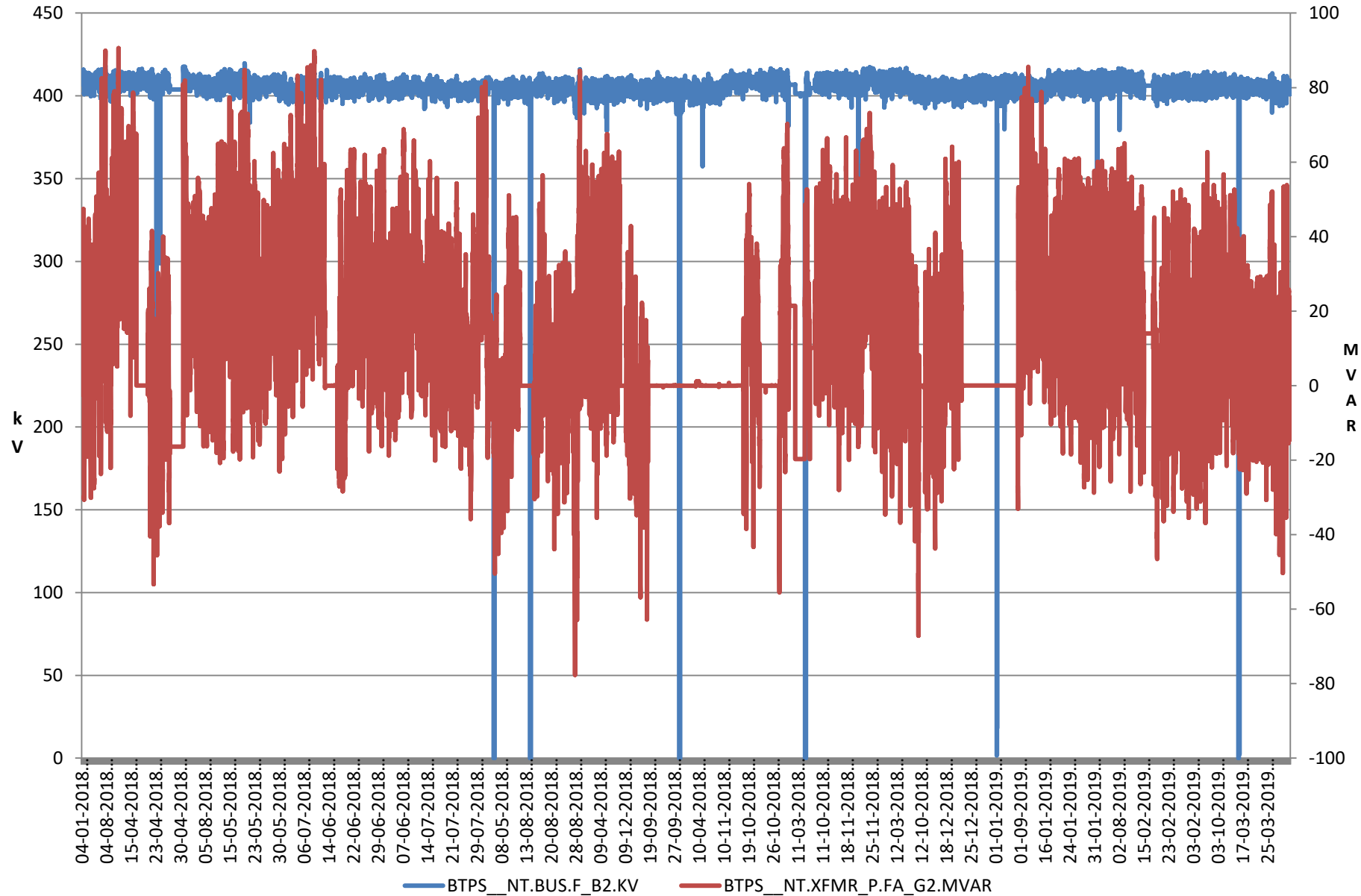

BgTPP
response is
satisfactory

PALATANA BUS1 VOLTAGE VS GTG1 MVAR

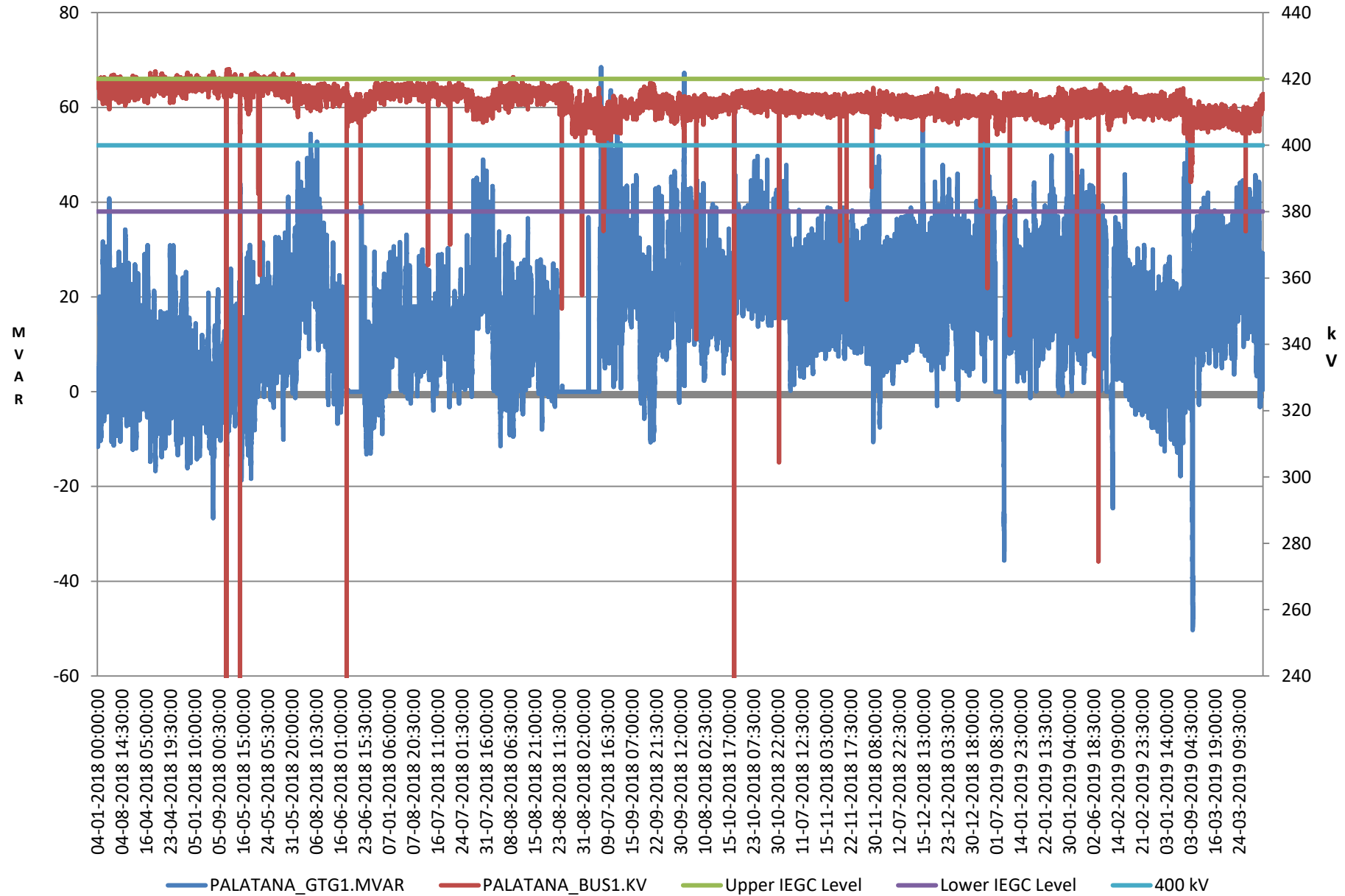

OTPC
response is
not
satisfactory ;
not absorbing
reactive
Power.

PALATANA BUS1 VOLTAGE VS GTG2 MVAR

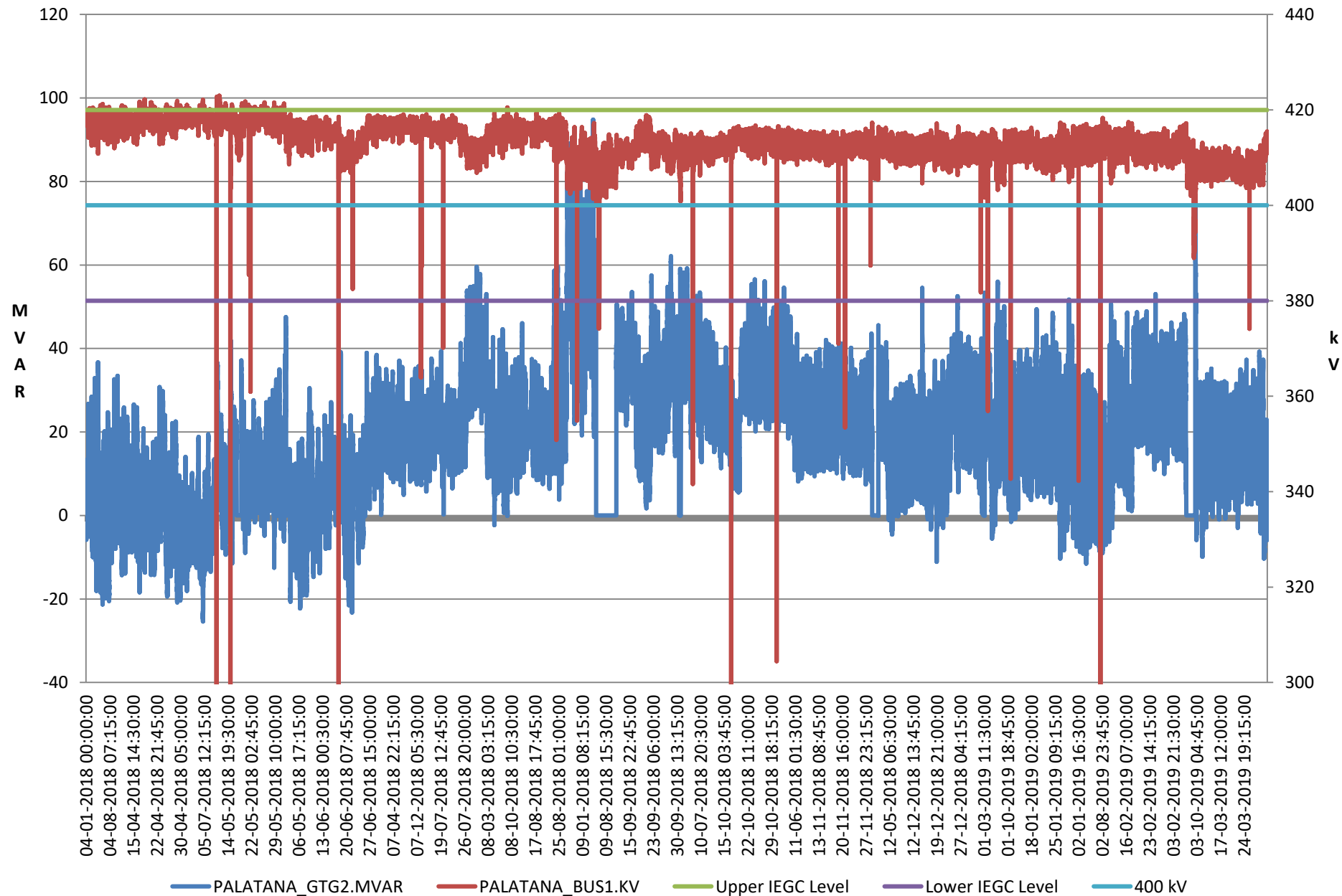

OTPC
response is
not
satisfactory ;
not absorbing
reactive
Power.

PALATANA BUS1 VOLTAGE VS STG1 MVAR

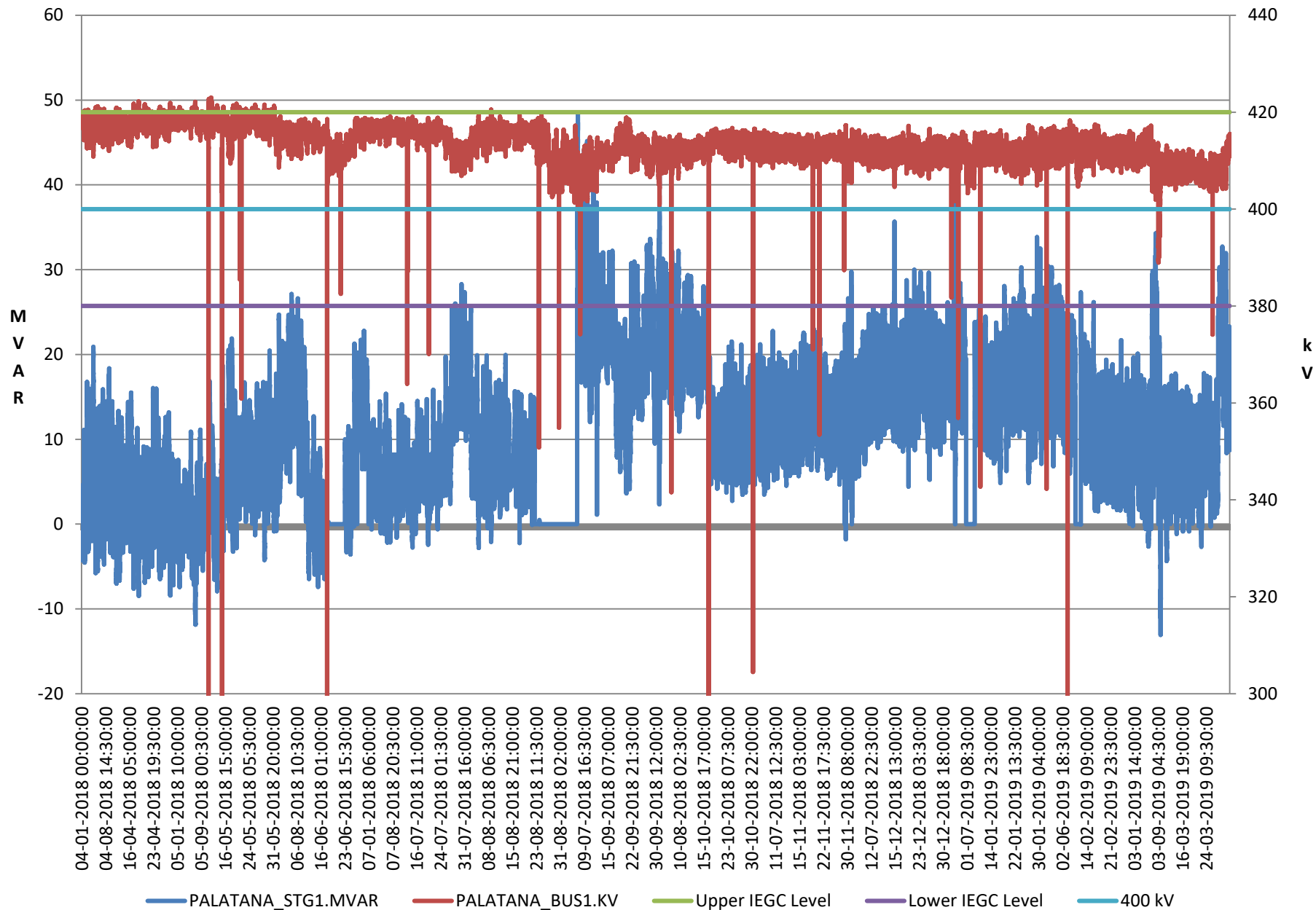

**OTPC
response is
not
satisfactory ;
not absorbing
reactive
Power.**

PALATANA BUS1 VOLTAGE VS STG2 MVAR

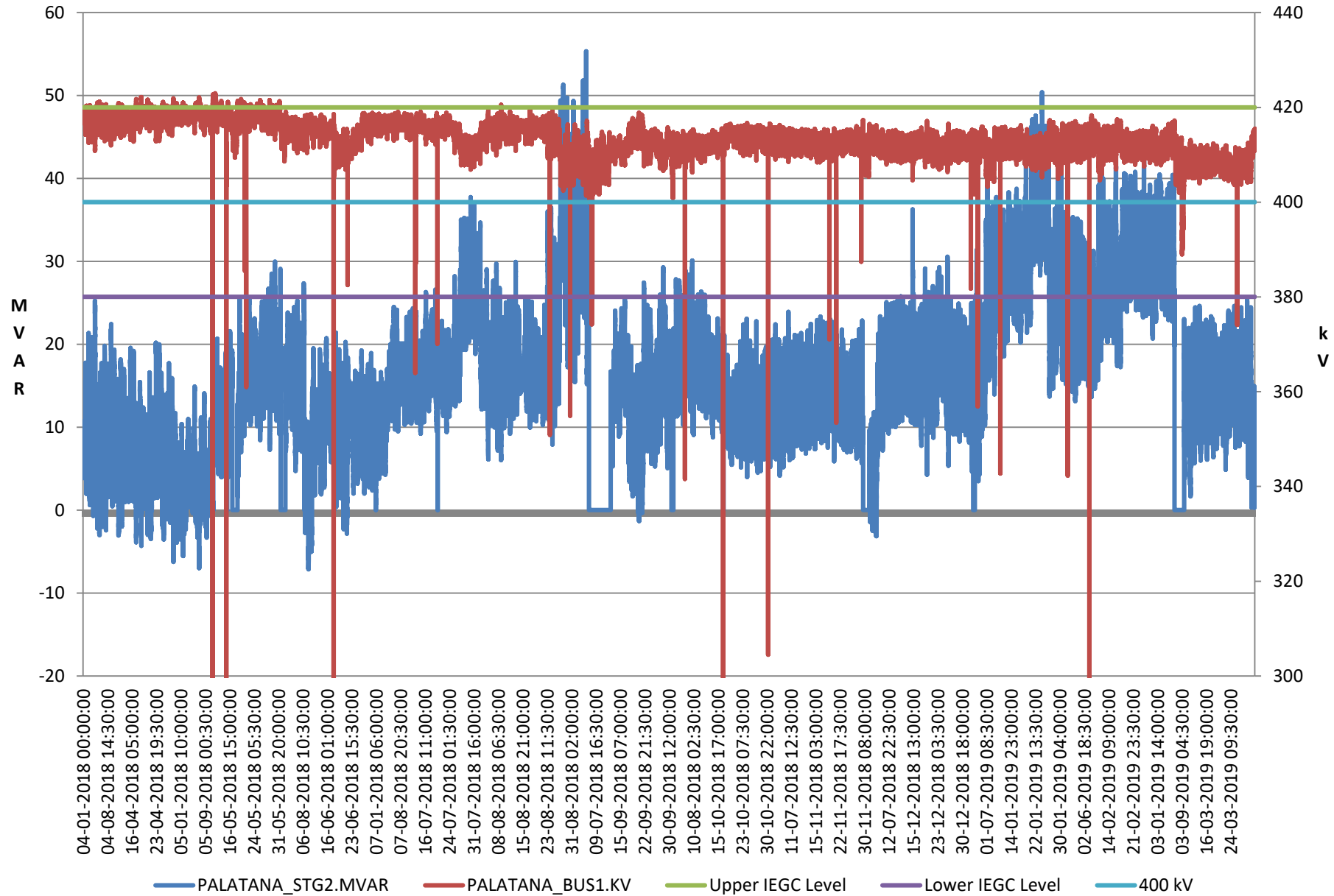

OTPC
response is
not
satisfactory ;
not absorbing
reactive
Power.

Security Constrained Economic Despatch

**Optimisation of Generation
Pilot project wef 01.04.2019**

Installed Capacity of Generators in SCED

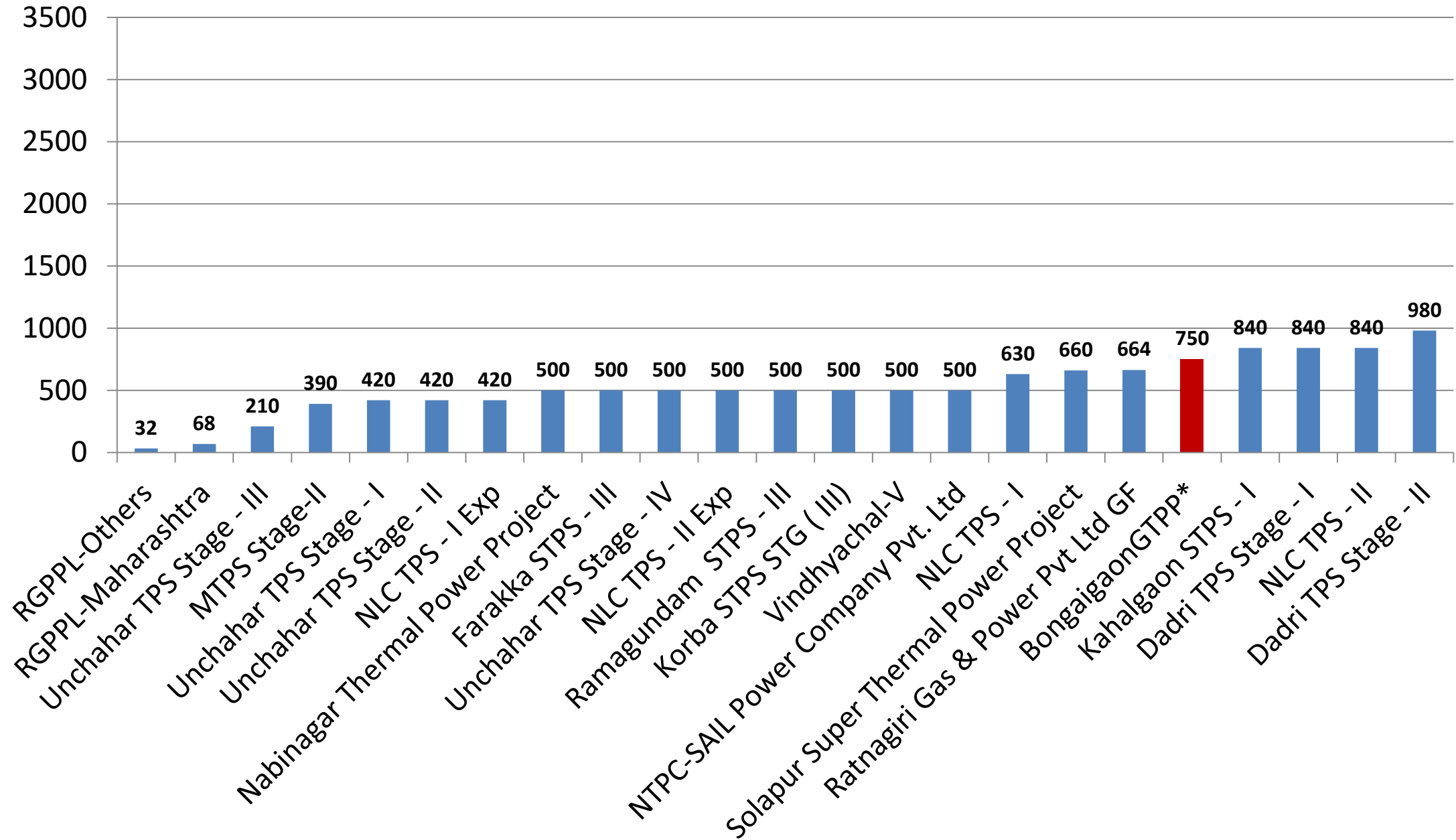

Installed Capacity of Generators in SCED

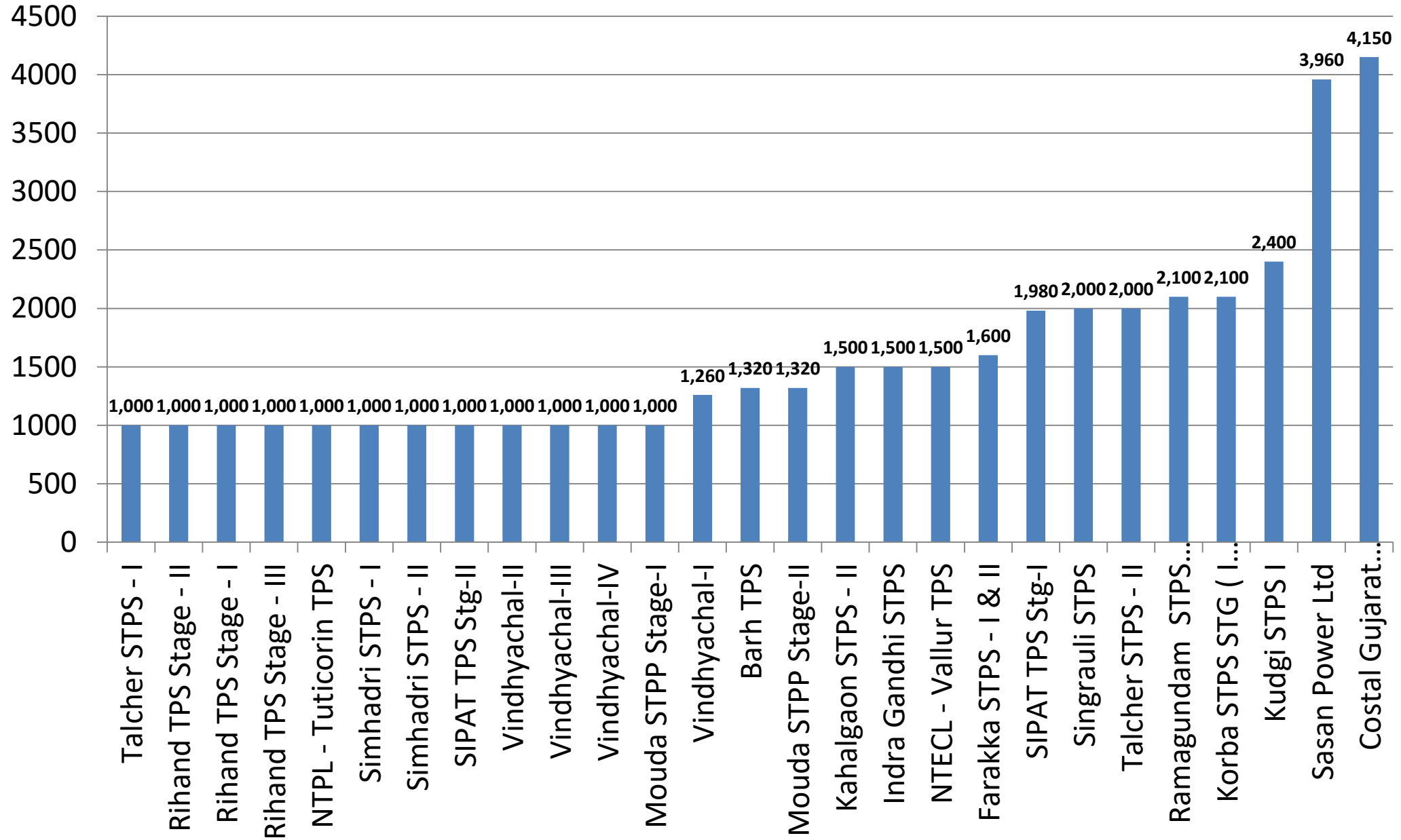

Variable cost of Generator paise/unit

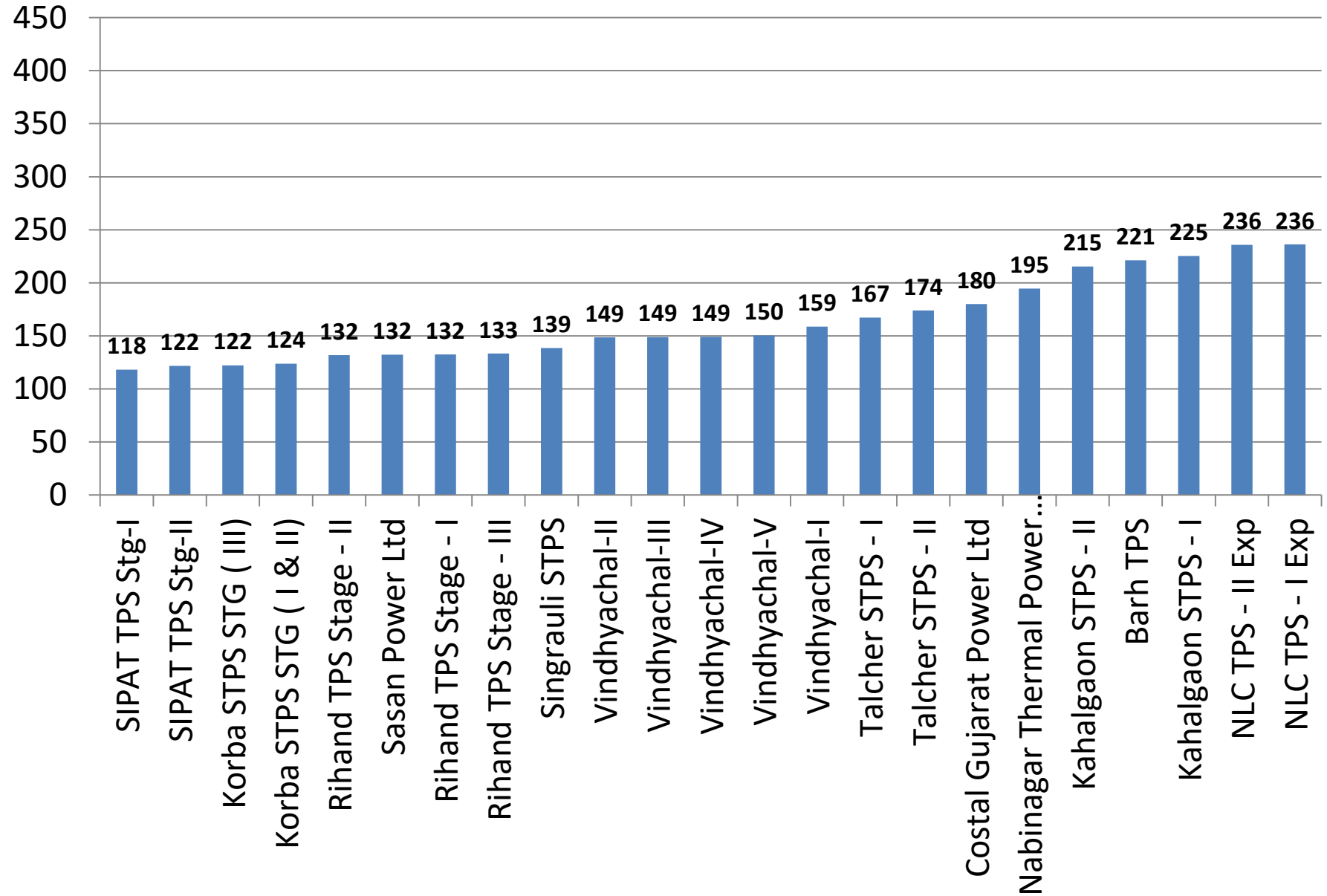

Variable cost of Generator paise/unit

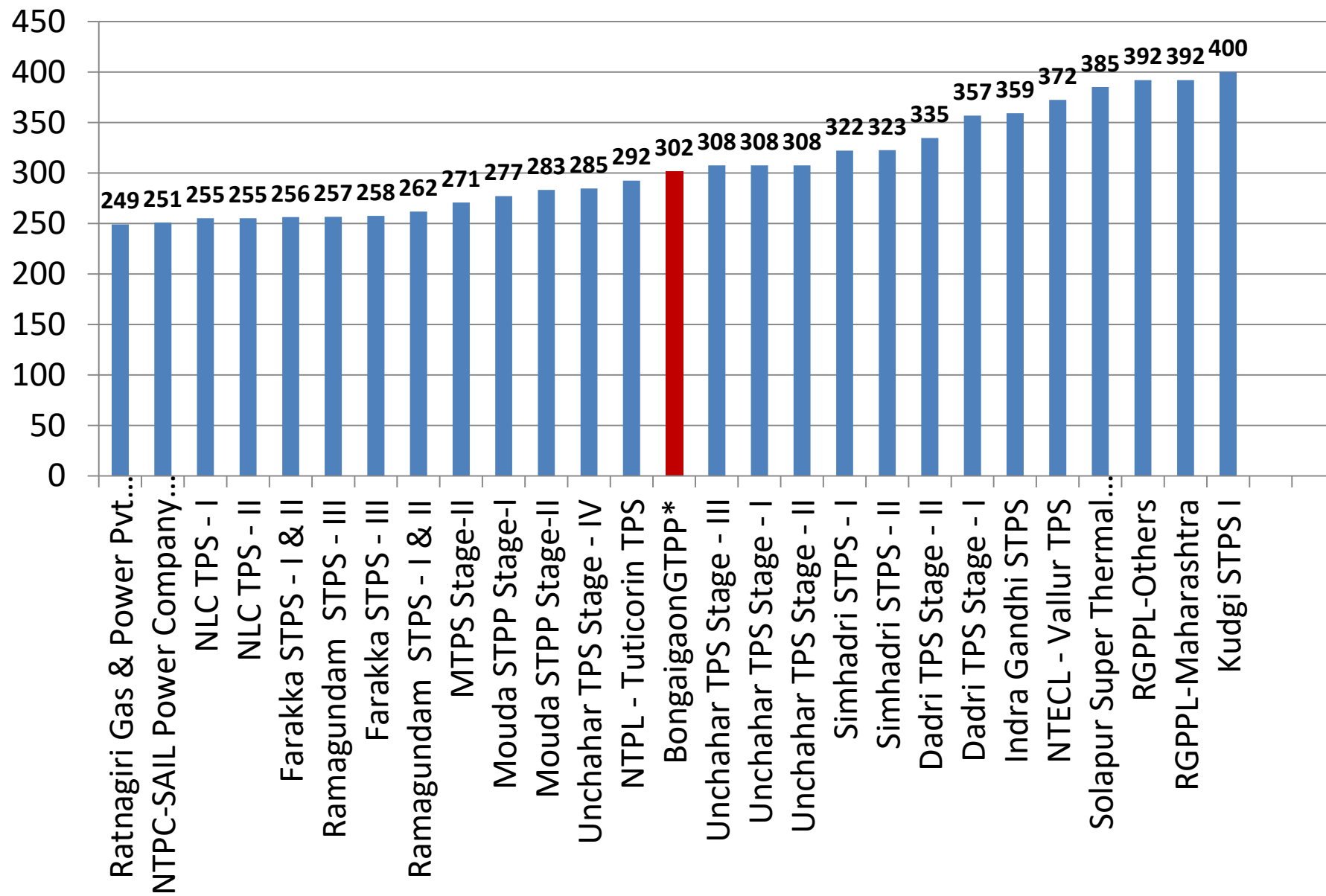

BgTPP ISGS Schedule & SCED for 03.04.2019

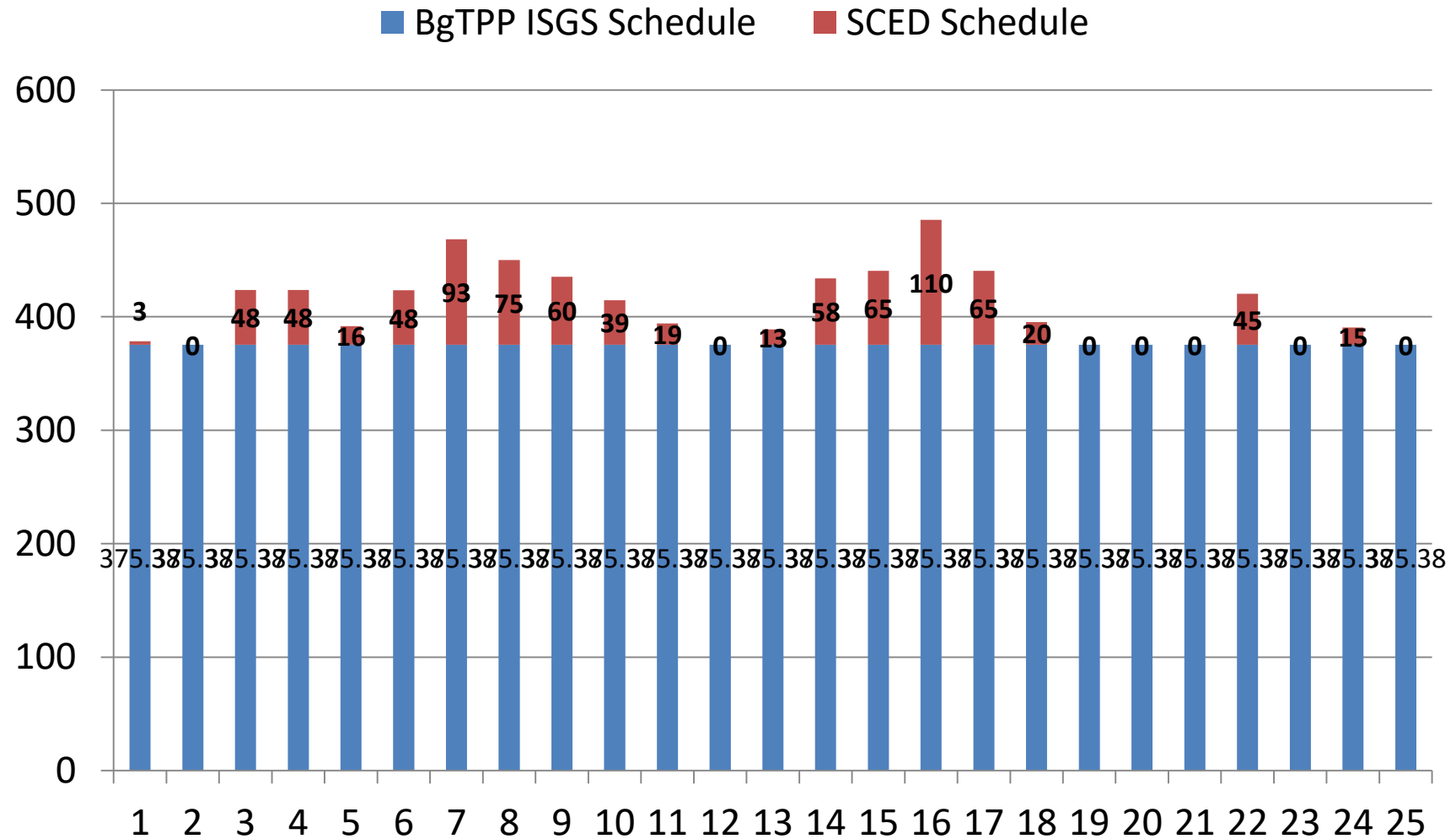

BgTPP ISGS Schedule & SCED for 03.04.2019

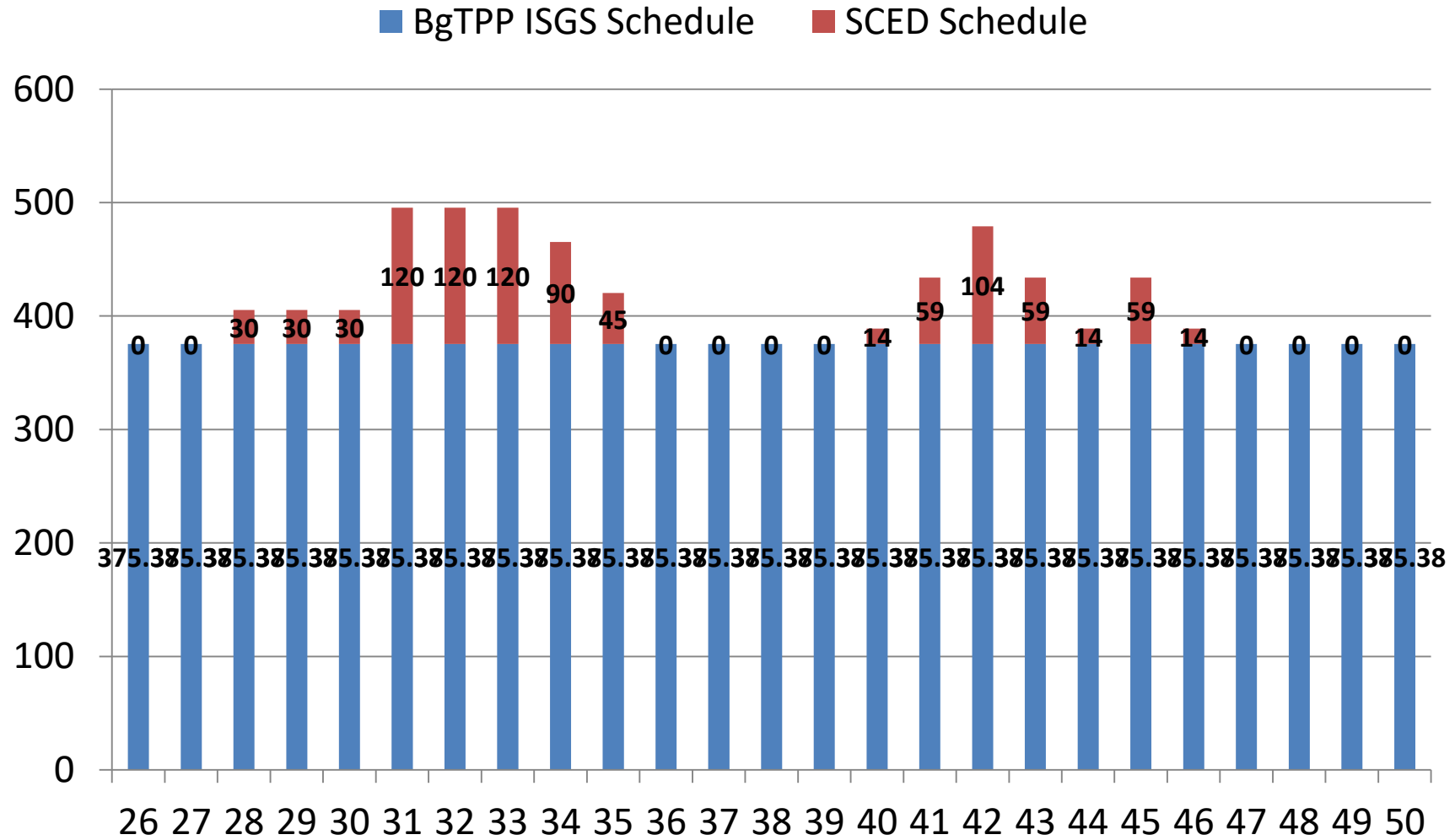

BgTPP ISGS Schedule & SCED for 03.04.2019

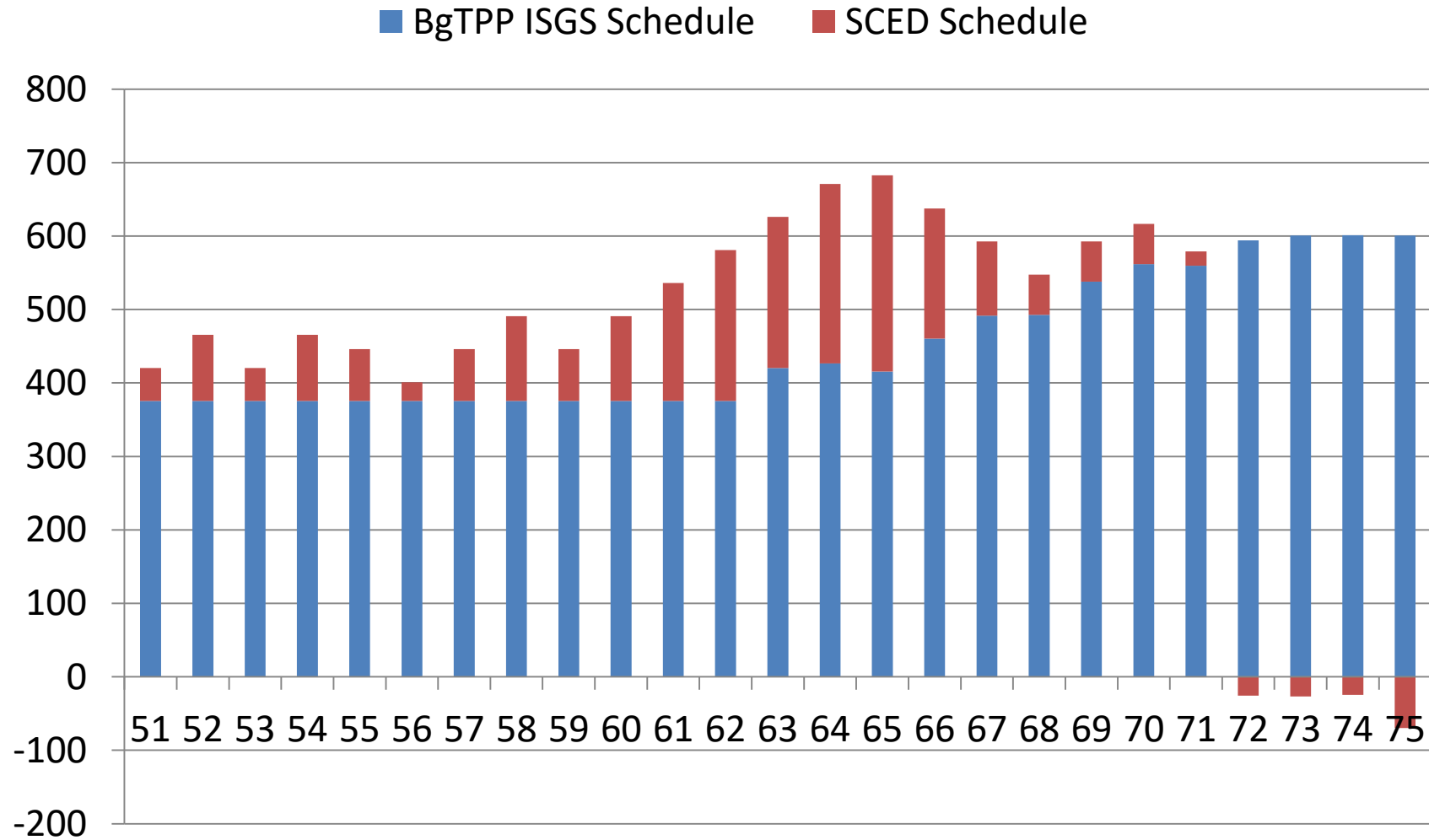

BgTPP ISGS Schedule & SCED for 03.04.2019

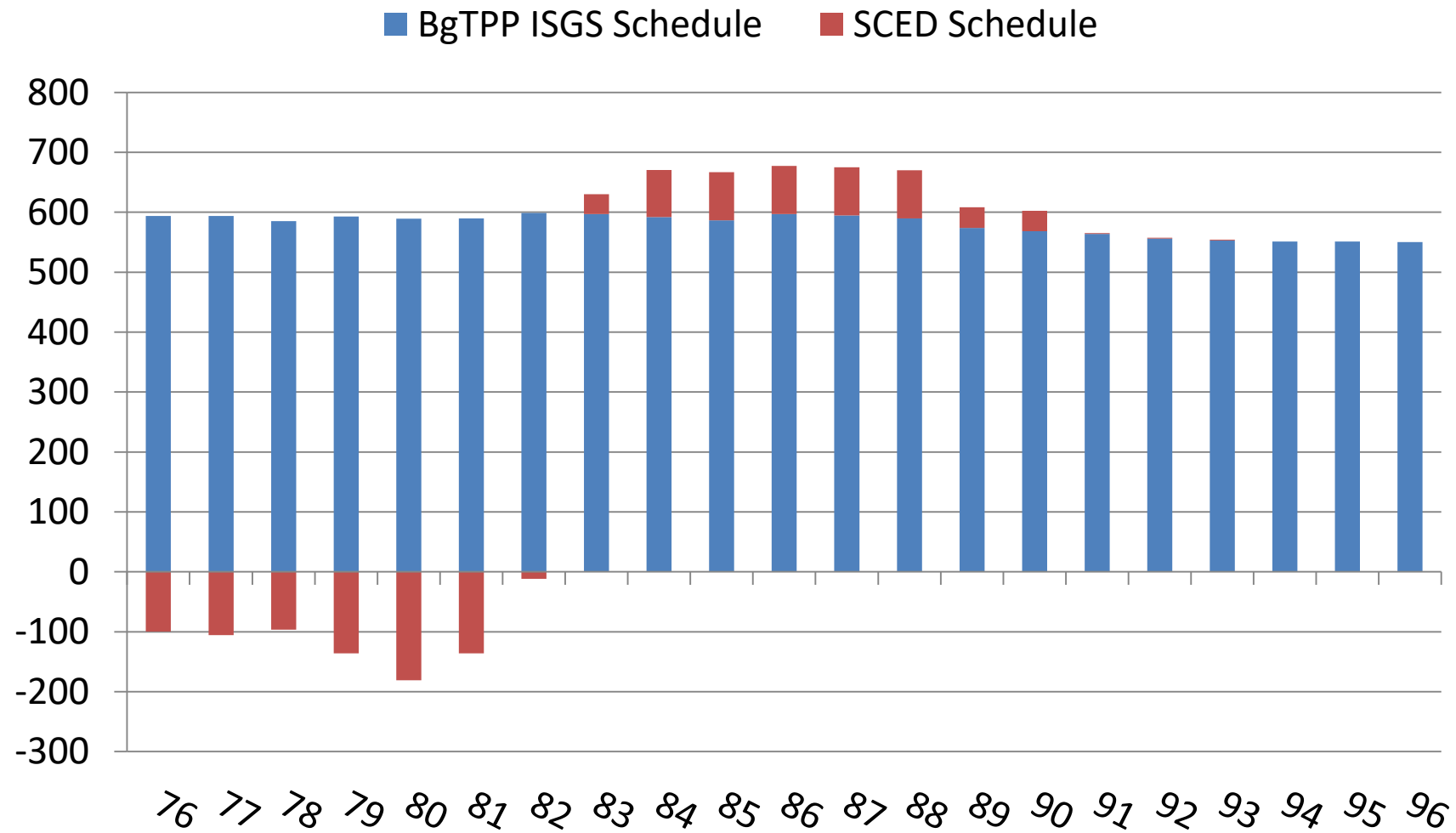

THANK YOU



उ.पू.क्षे गिड प्रदर्शन

NER GRID PERFORMANCE

For the year 2018-2019

North Eastern Regional Load Despatch Centre

POSOCO, Shillong

ZERO CROSSING VIOLATION – NER STATES

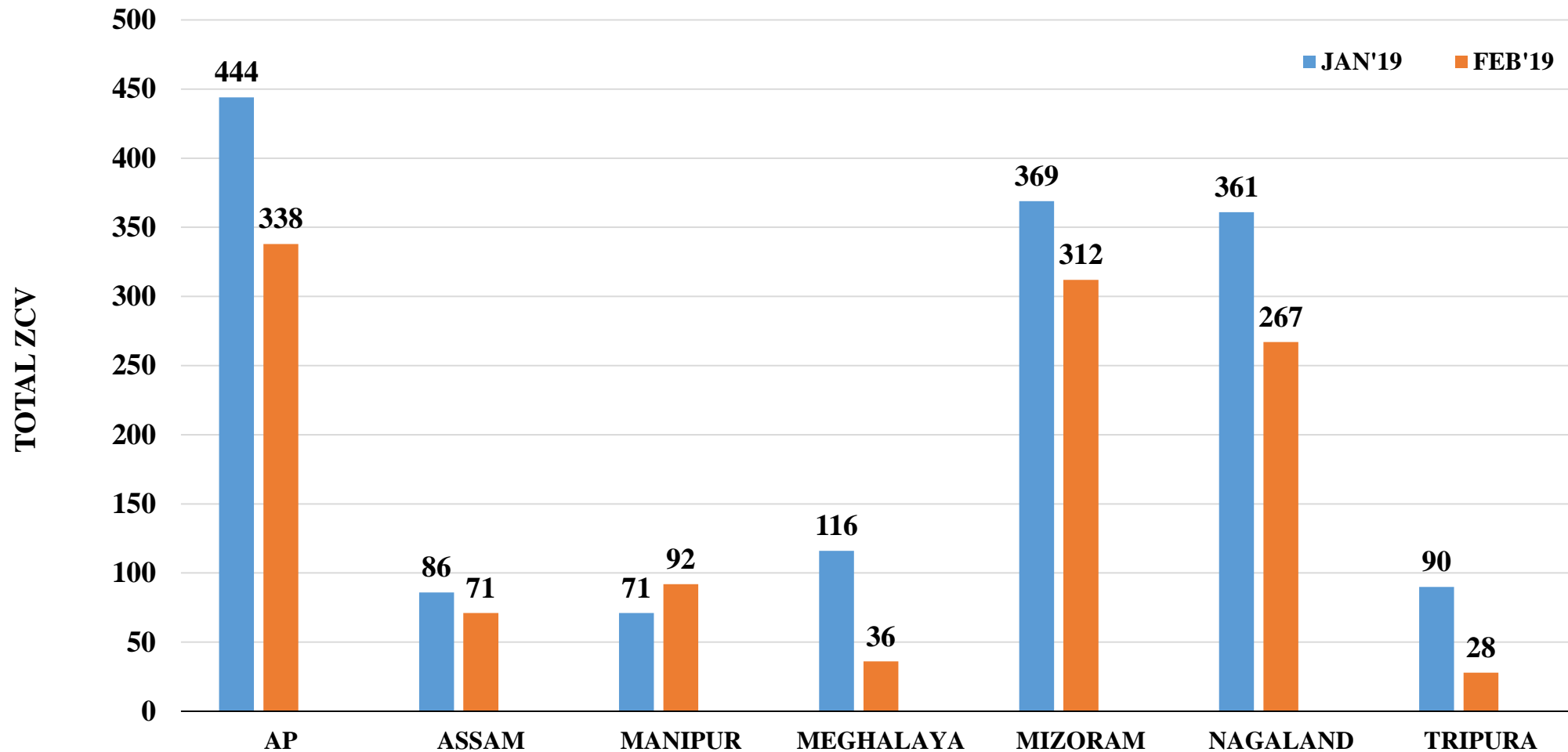

Ar. Pradesh, Mizoram and Nagaland need to take urgent measures to control ZCV and adhere to grid discipline.

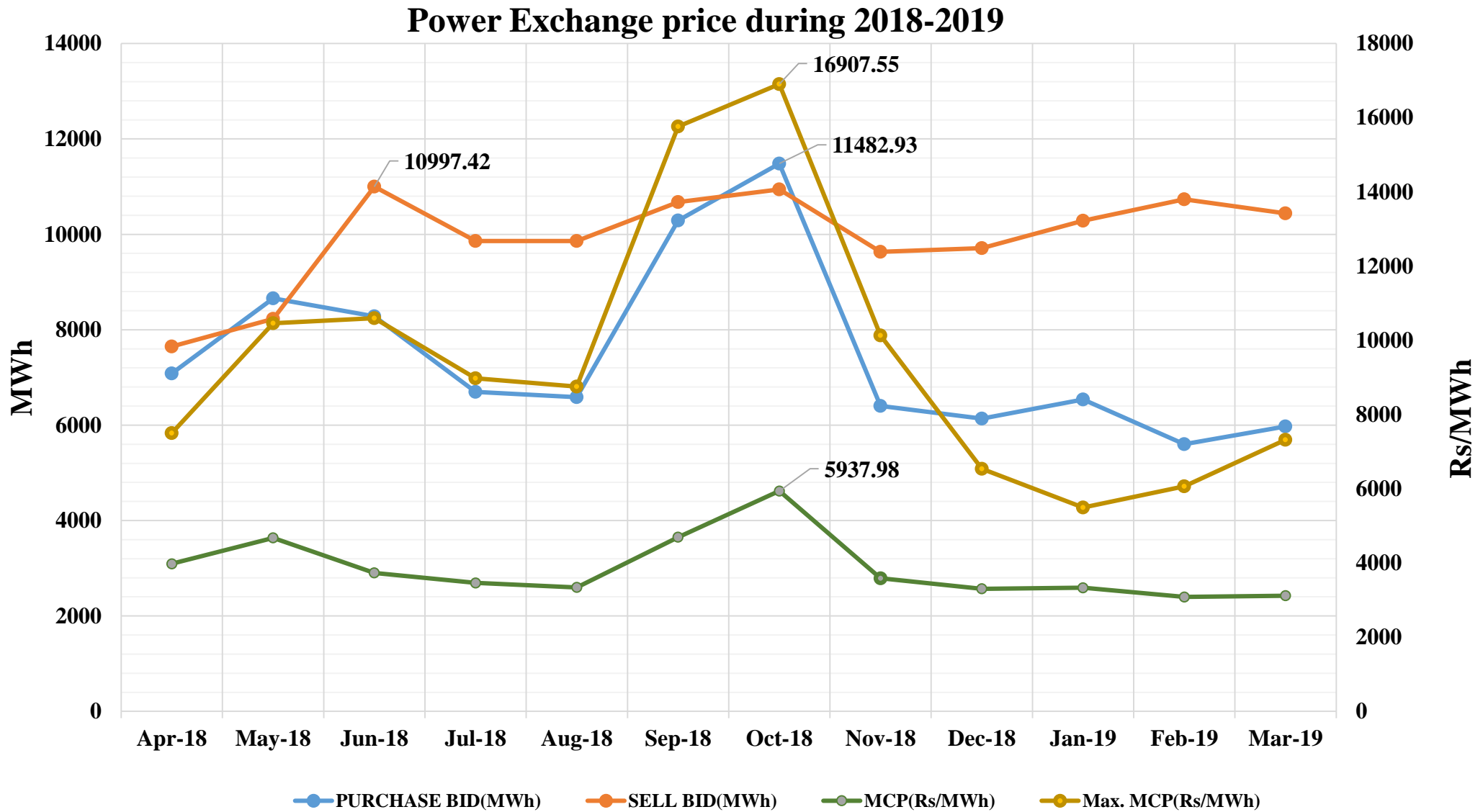

DSM is linked to Power exchange price (ACP). States need to look into and analyse the same.

Line Tripping Details during 2018-2019

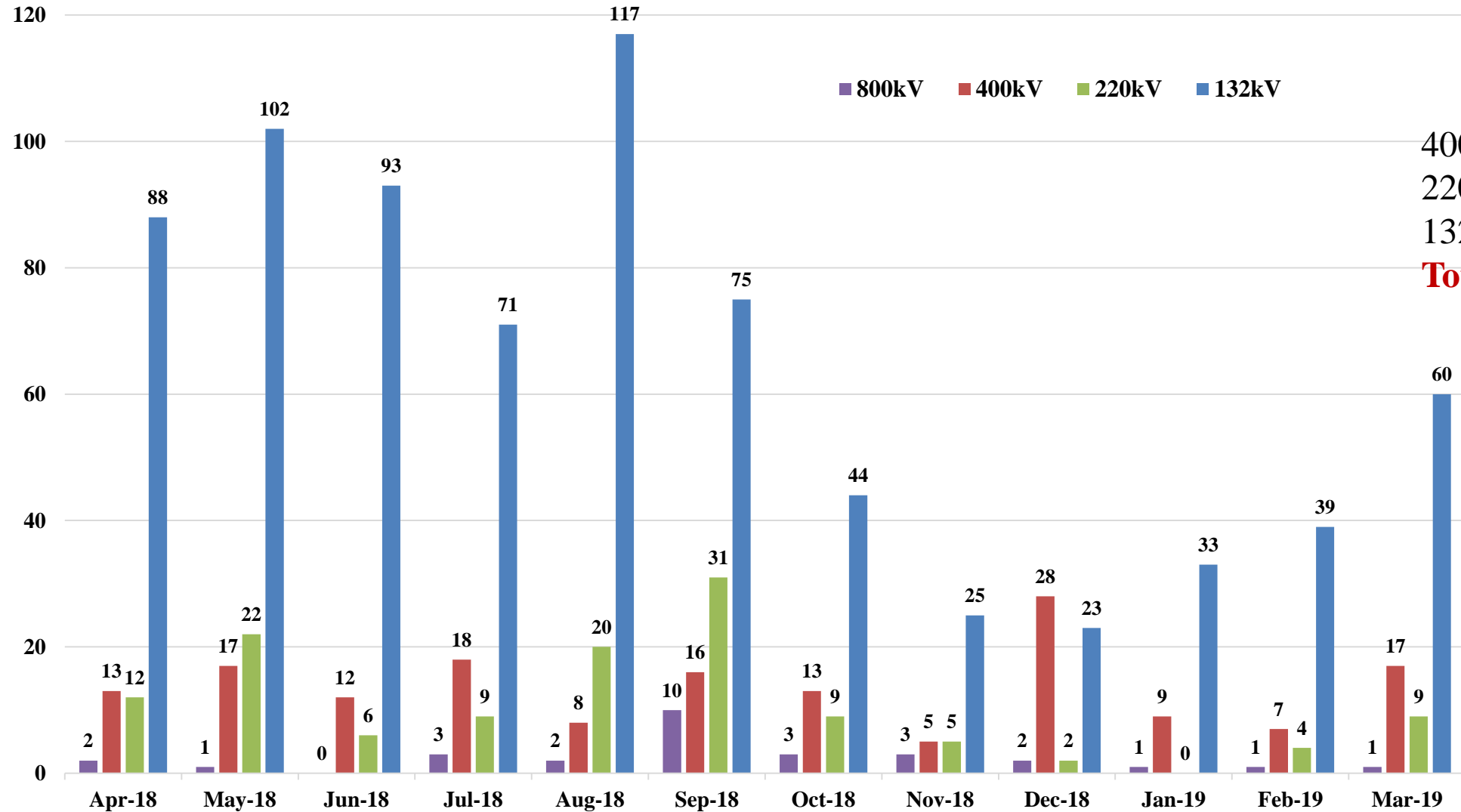

400 kV: 163
 220 kV: 129
 132 kV: 770
Total : 1062

Line tripping during the years touched 1000, need to take measures to arrest.

Grid disturbances and Grid incidence during 2017-2018

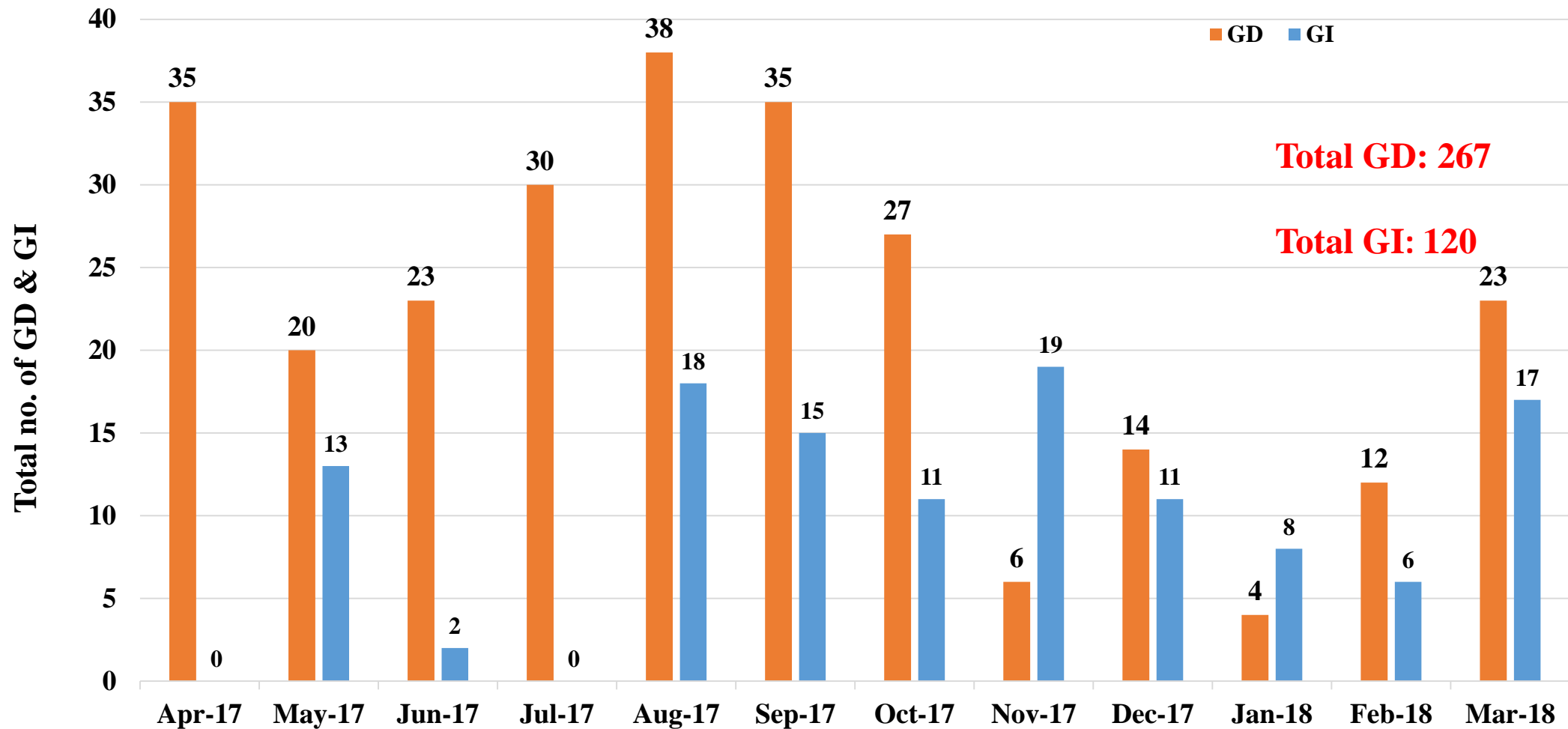

Grid disturbances, Grid Incidences in large numbers.

Grid Disturbances and Grid Incidence during 2018-2019

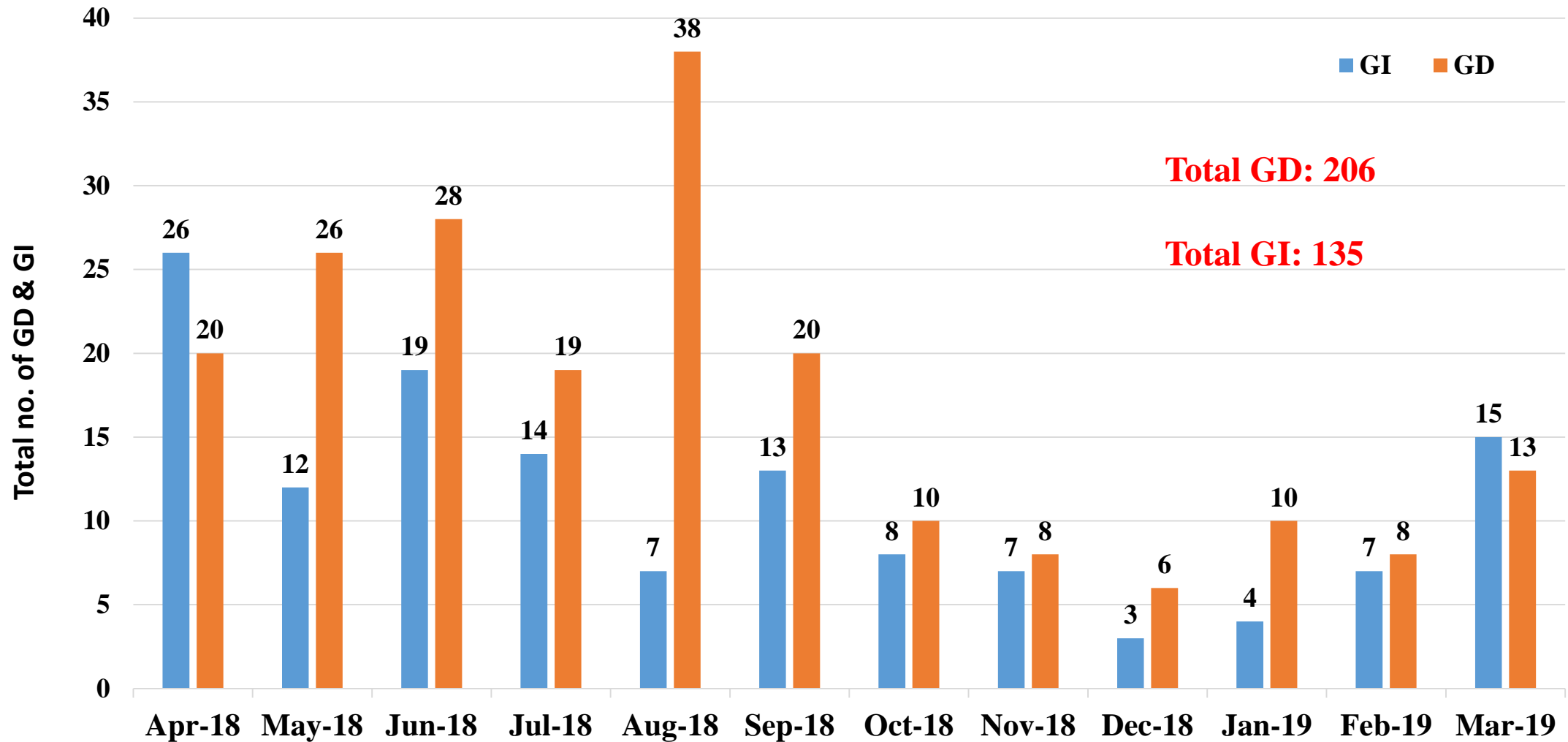

Grid incidences more than previous year.

Average Frequency 2018-19

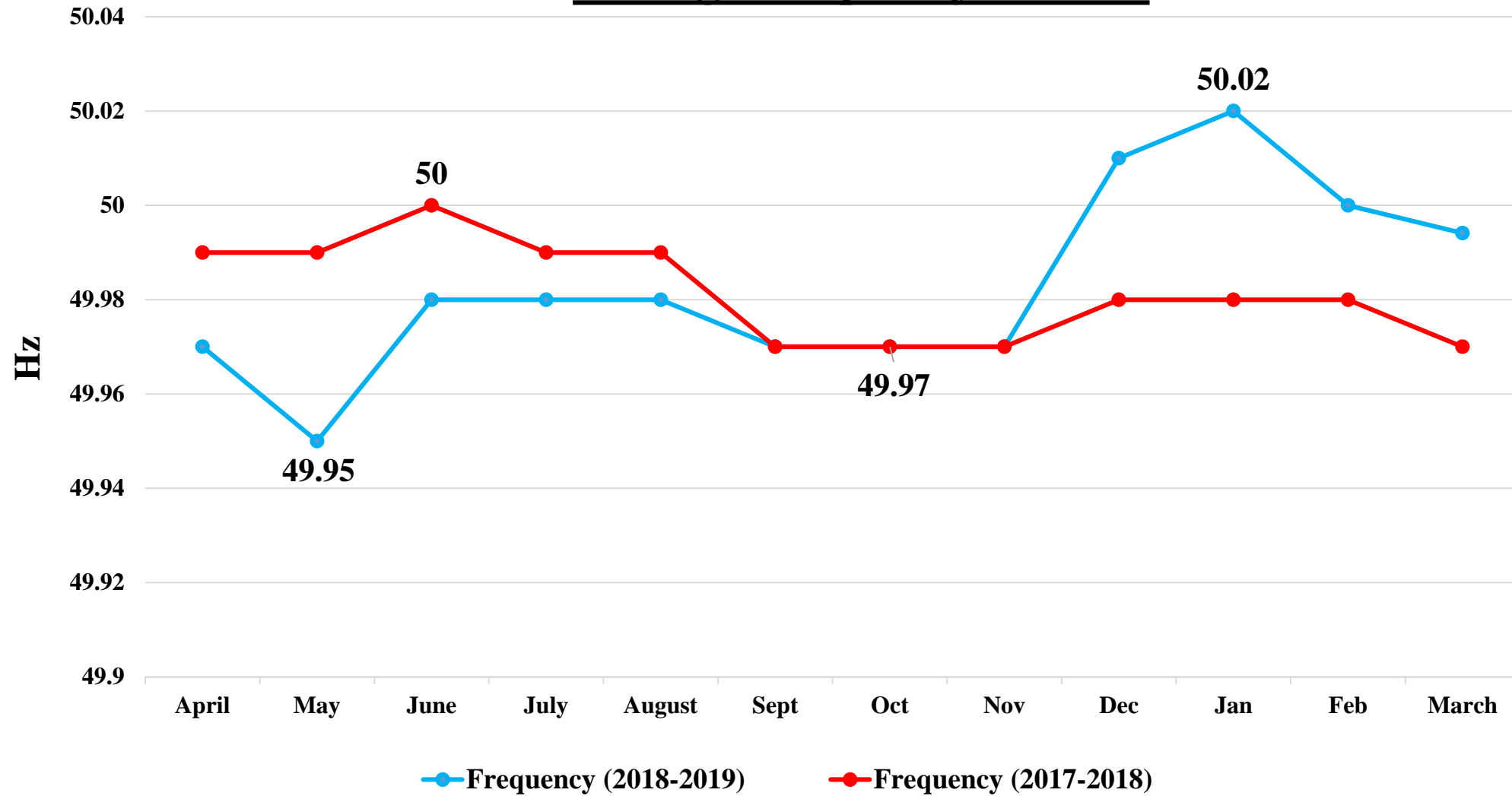

High frequency after DSM amendment, ZCV.

Energy met and Maximum demand met during 2017-18 & 2018-19

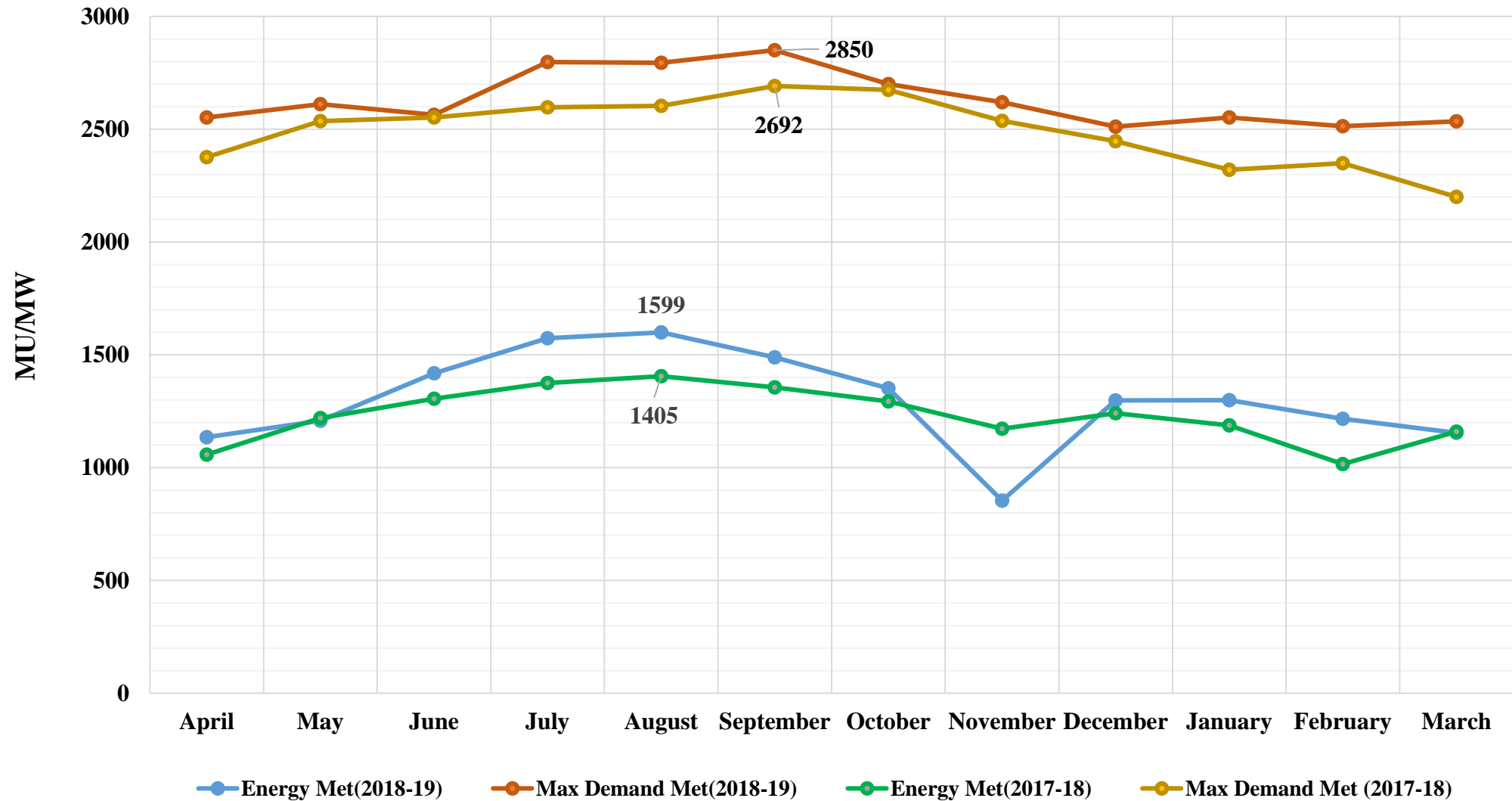

No growth, stagnant both in terms of MW and Energy.

Number of 400 kV line openings due to Over-voltage during 2018-2019

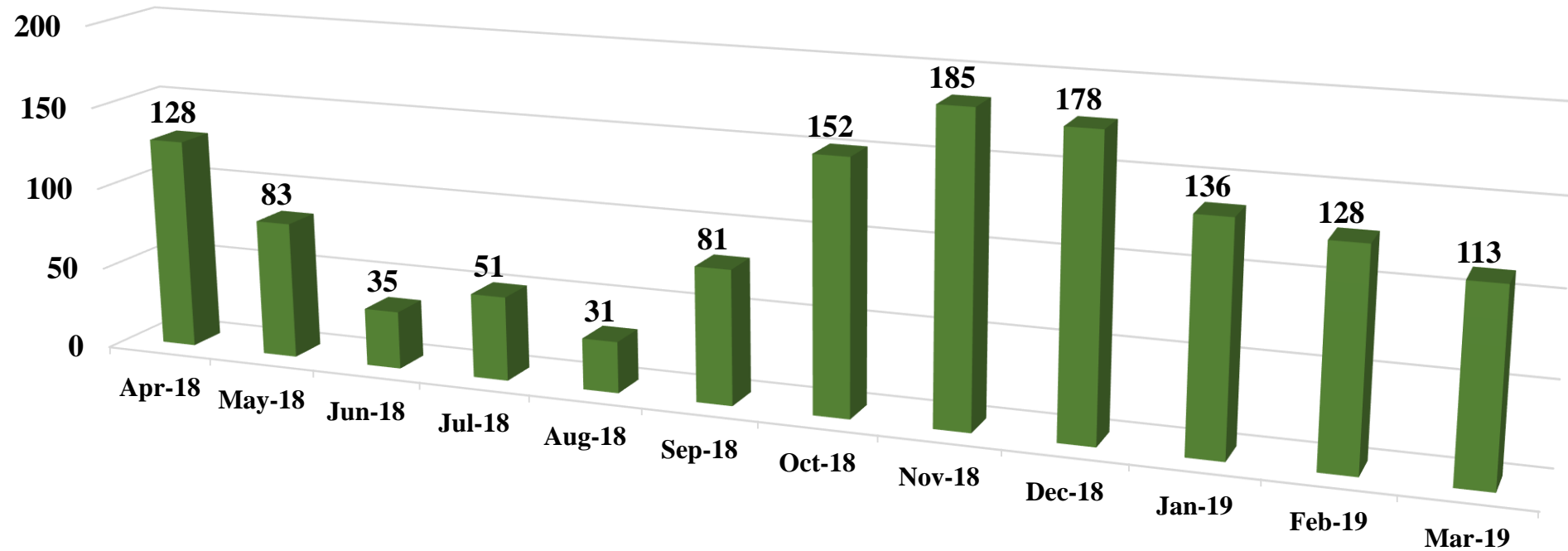

More line openings during lean hydro, maintenance of reactors to be planned accordingly.

No. of opening of 400 kV BNC-Ranganadi Circuit I & II during 2018-19

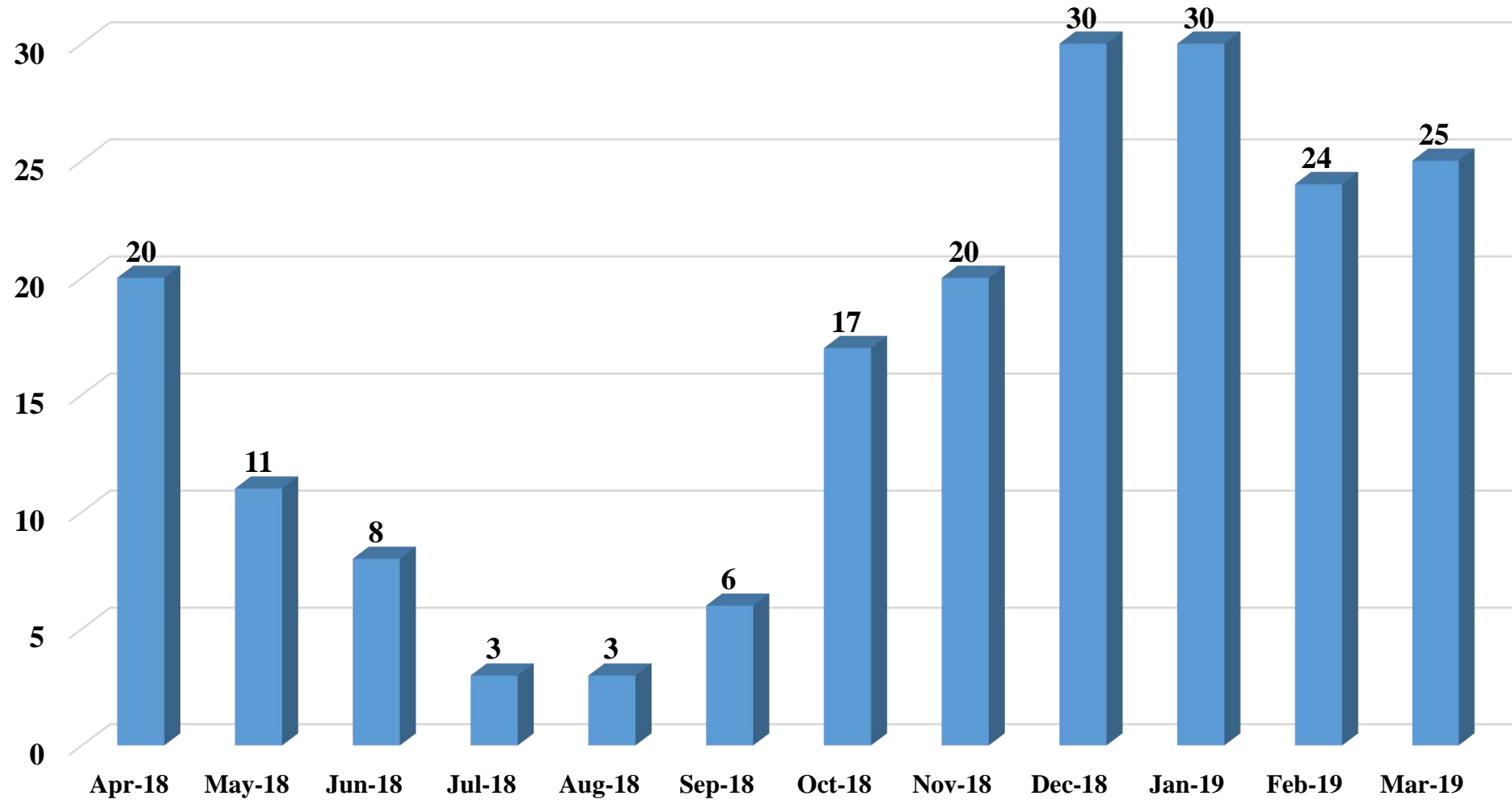

Large no. of openings of BNC-Ranganadi emphasises need of RHEP synchronous condenser operation.

Total Approved Shutdown during 2018-2019

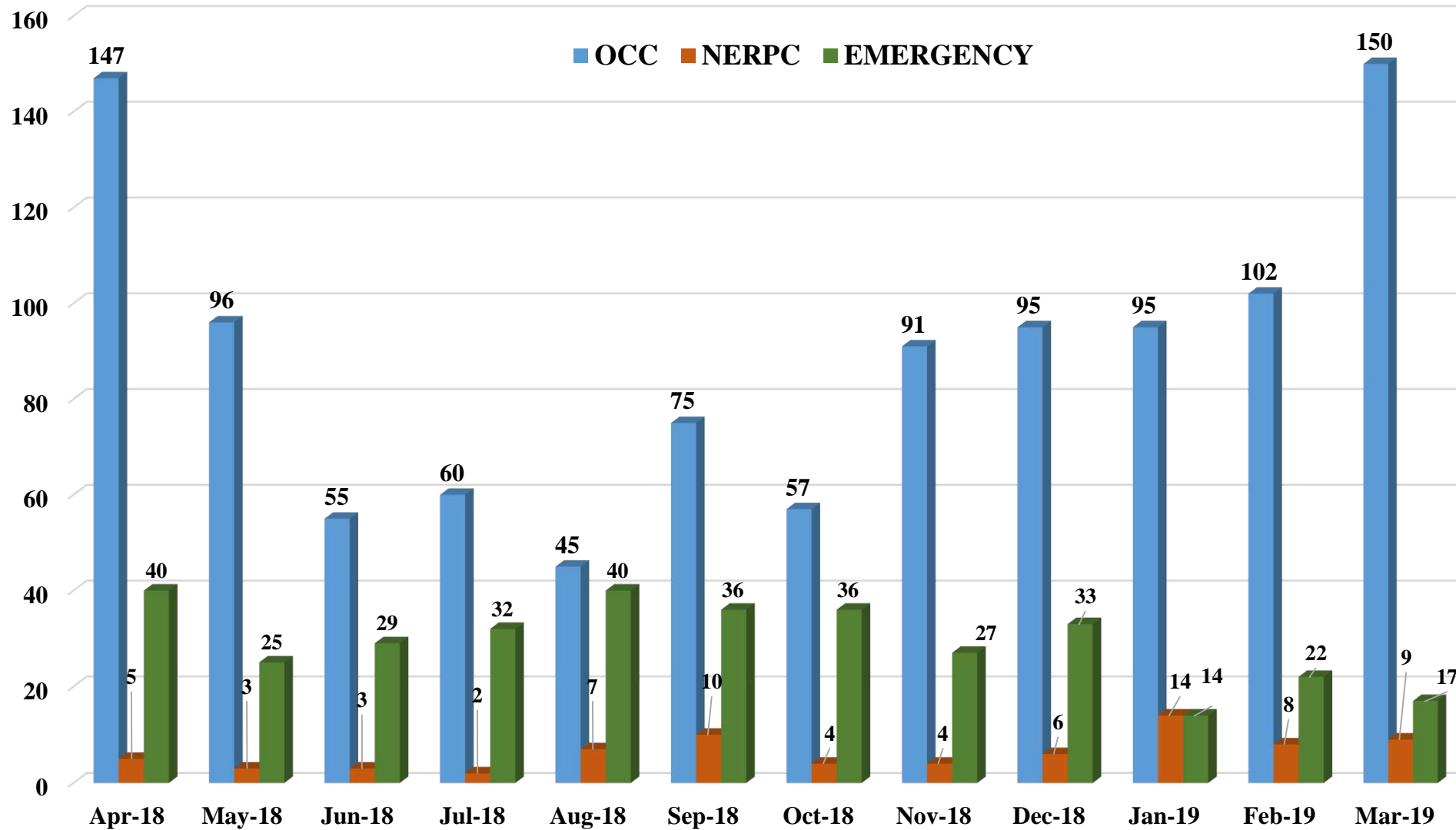

OCC: 1068
 NERPC: 75
 EMER: 351
Total: 1494

Handling and managing large numbers of S/D is a challenge.

Emergency shutdown(%) of OCC Approved

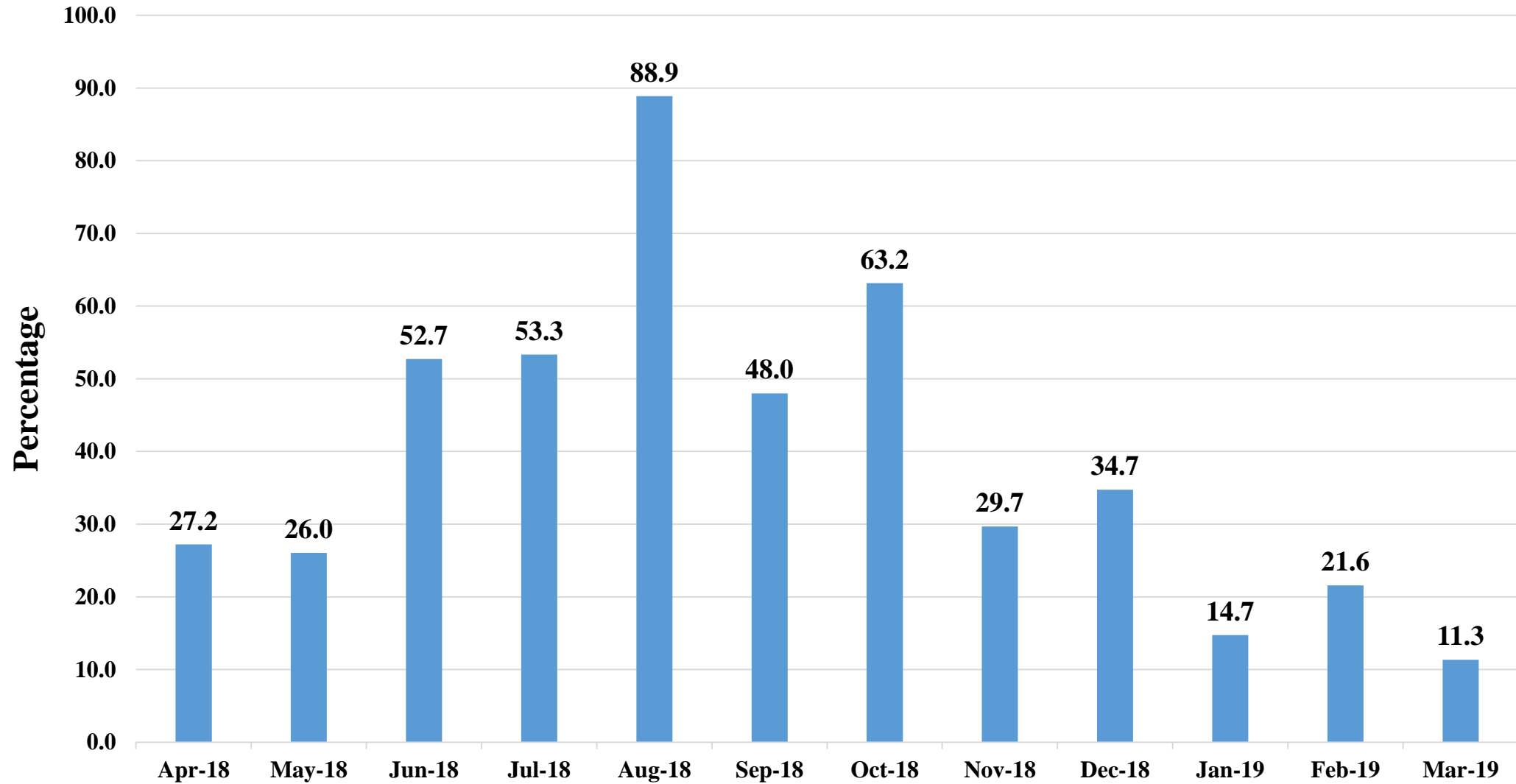

Emergency shutdown has to be minimised.

Approved shutdown Vs Aailed shutdown

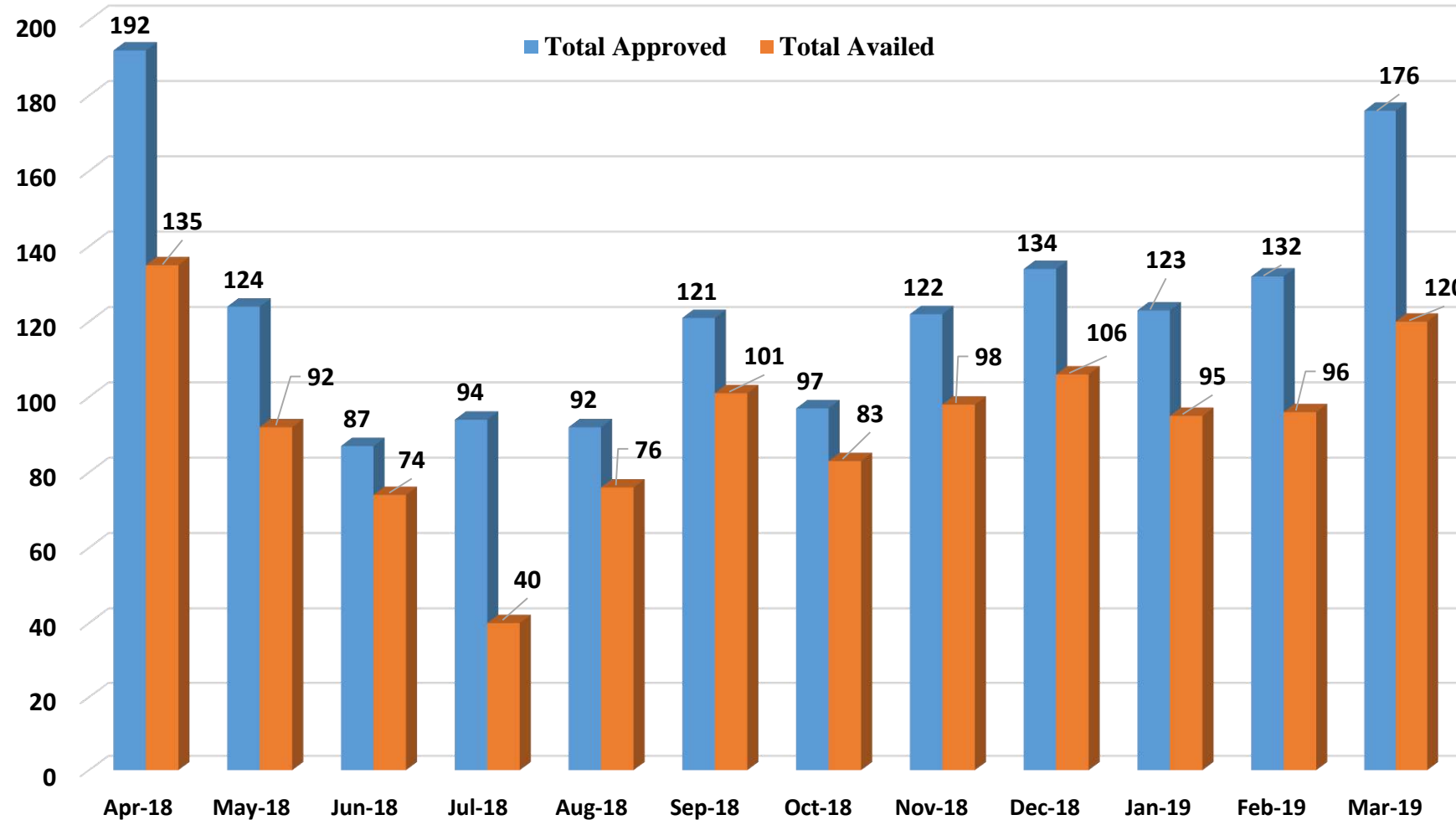

App: 1494
Avail: 1116

Substantial number of approved shutdowns are not aailed.

Availed shutdown (%) of Approved shutdown

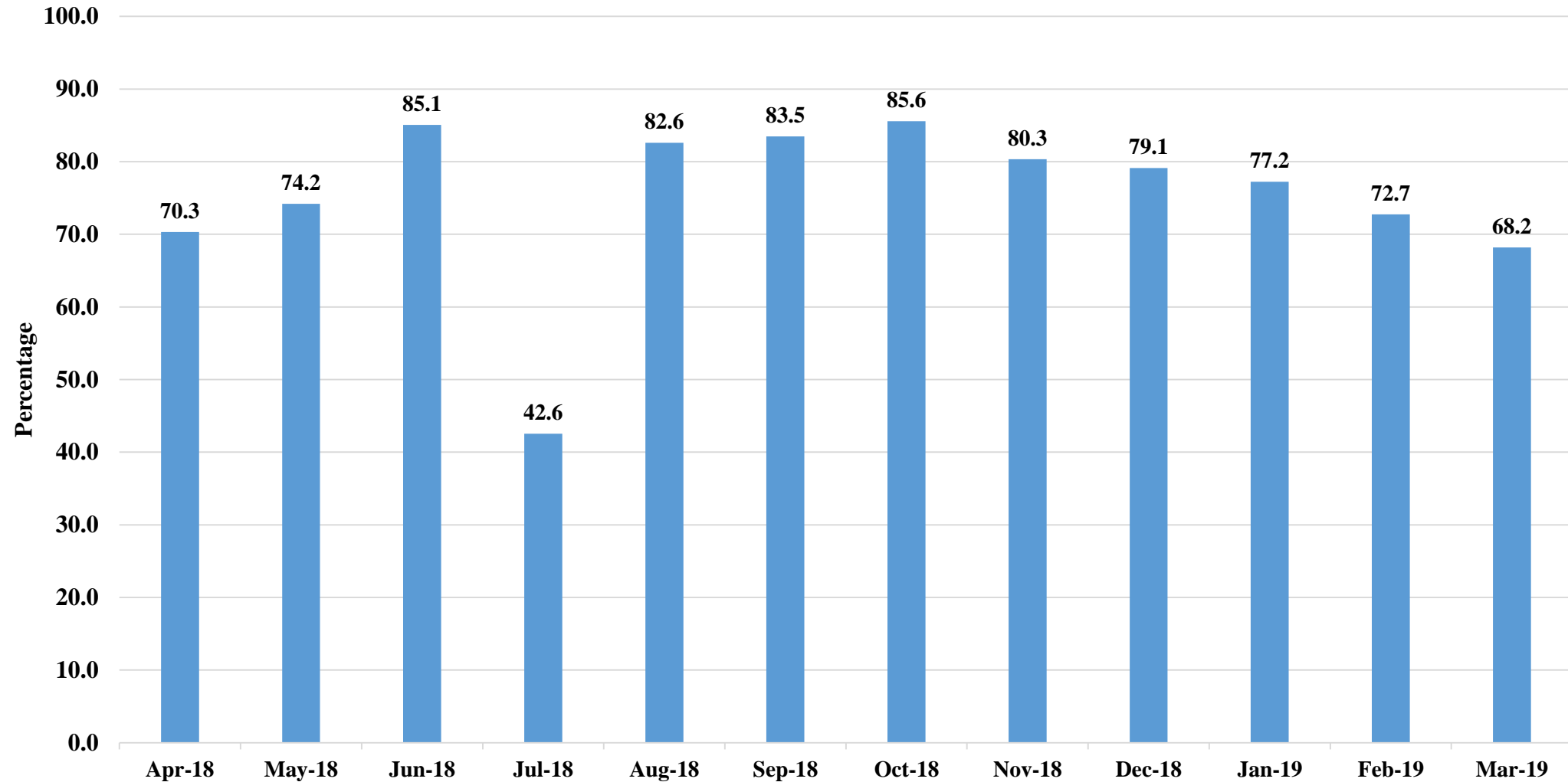

On an average 30% of approved is not availed creating problems in coordination.

New elements during 2018-19.

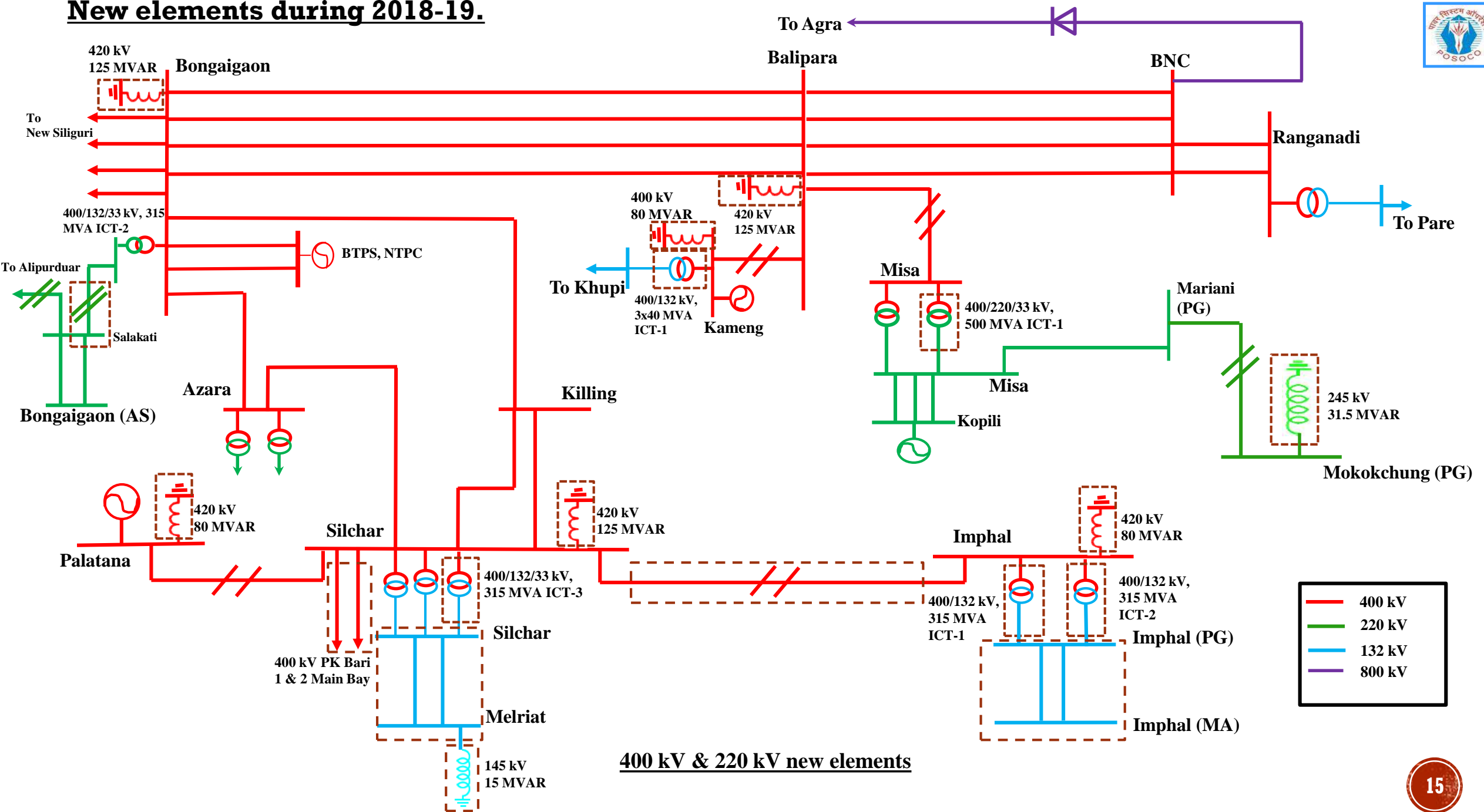

New elements during 2018-19.

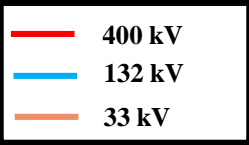
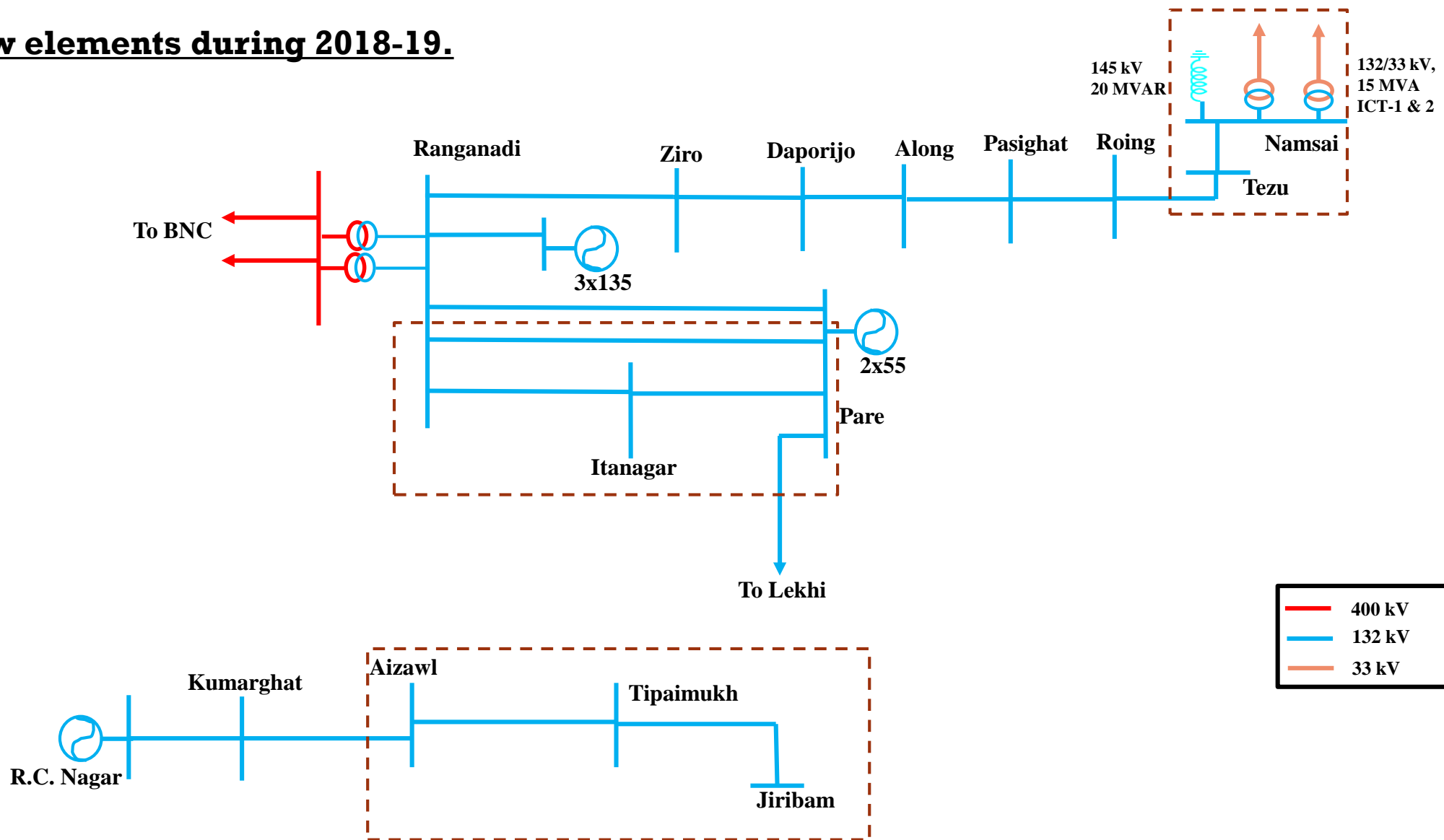

132kV New elements



BGTPP BUS1 VOLTAGE VS GENERATOR TRANSFORMER1 MVAR

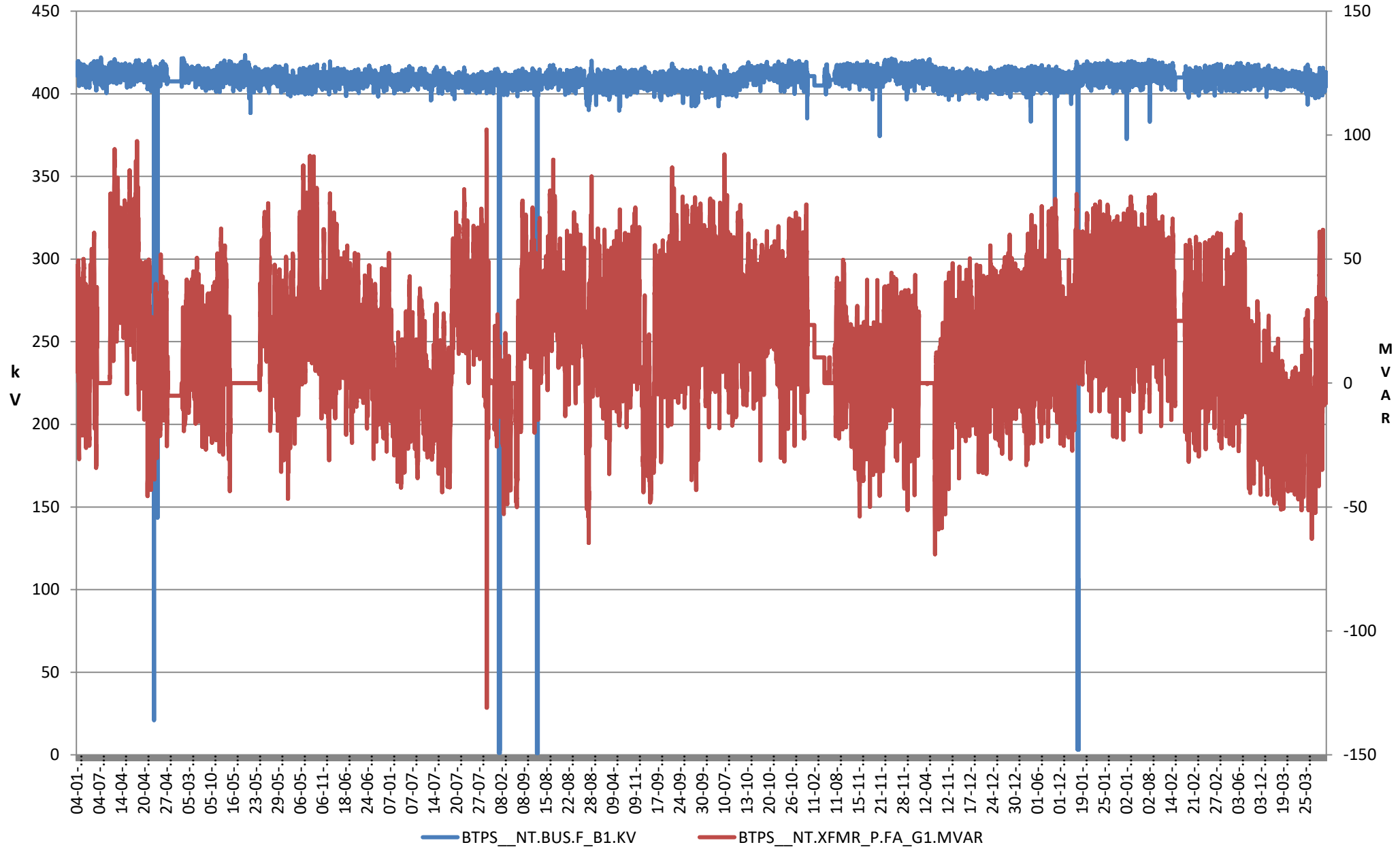

BgTTP
response is
satisfactory

BGTPP BUS2 VOLTAGE VS GENERATOR TRANSFORMER2 MVAR

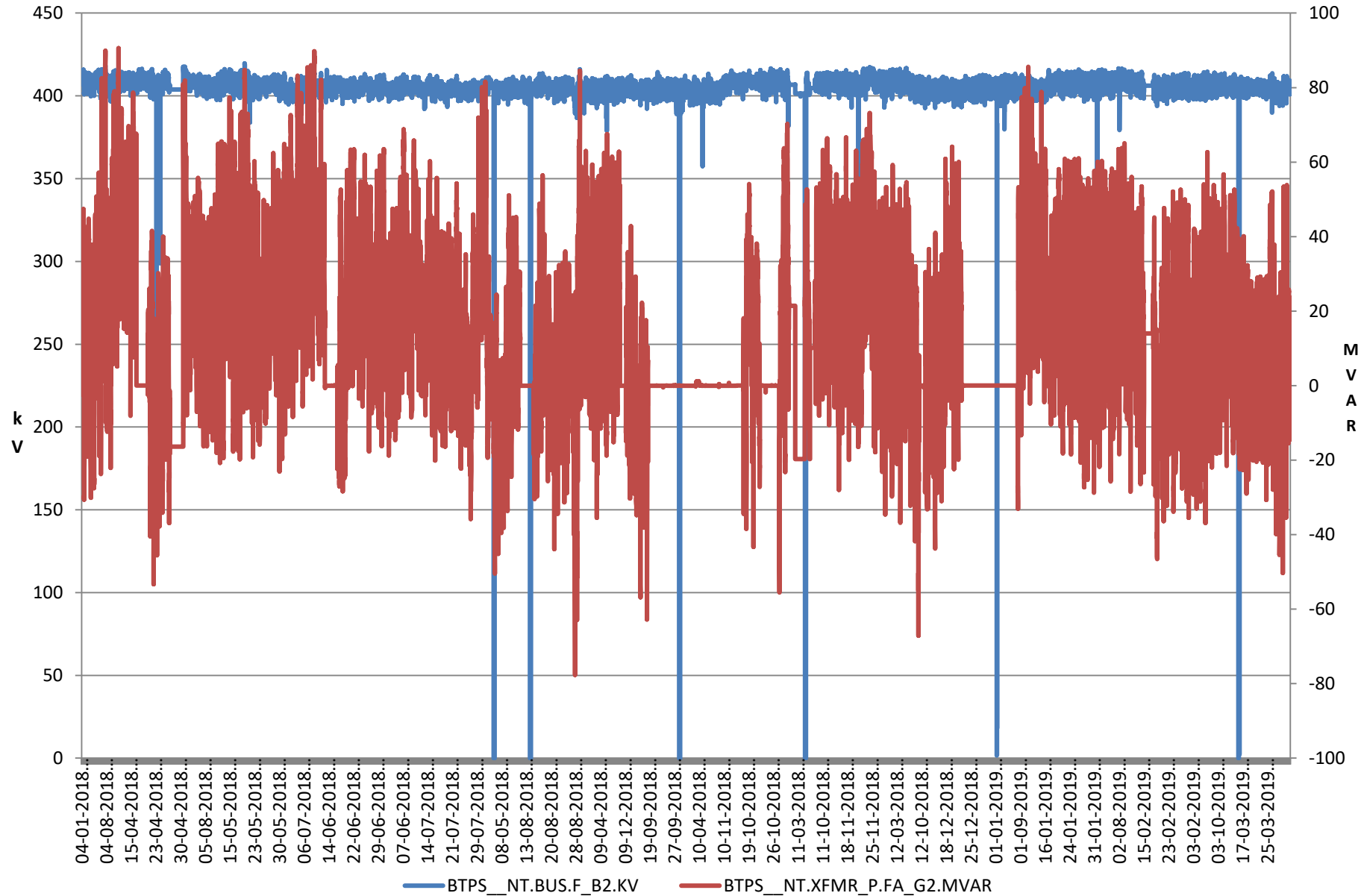

**BgTPP
response is
satisfactory**

PALATANA BUS1 VOLTAGE VS GTG1 MVAR

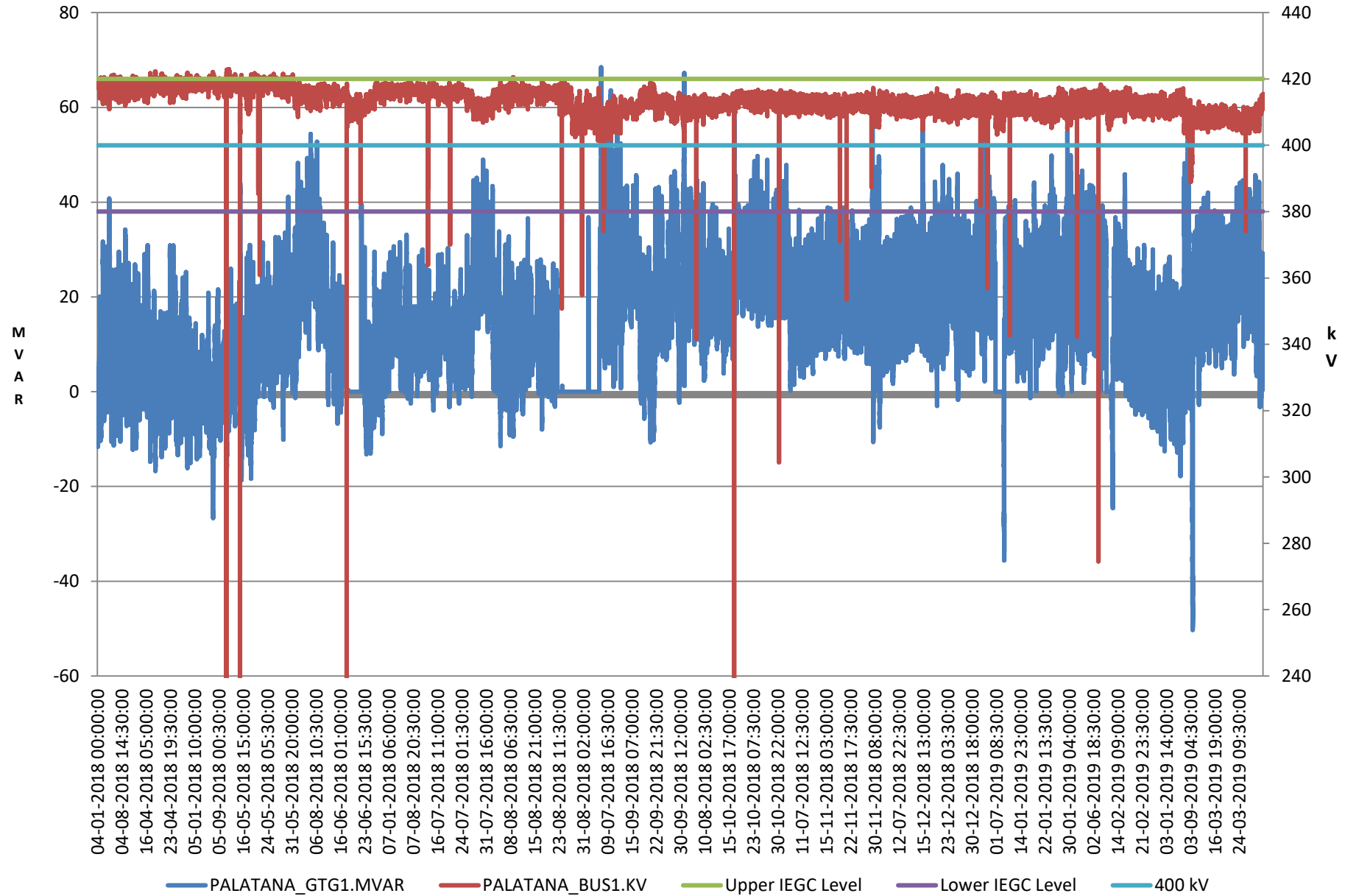

OTPC
response is
not
satisfactory ;
not absorbing
reactive
Power.

PALATANA BUS1 VOLTAGE VS GTG2 MVAR

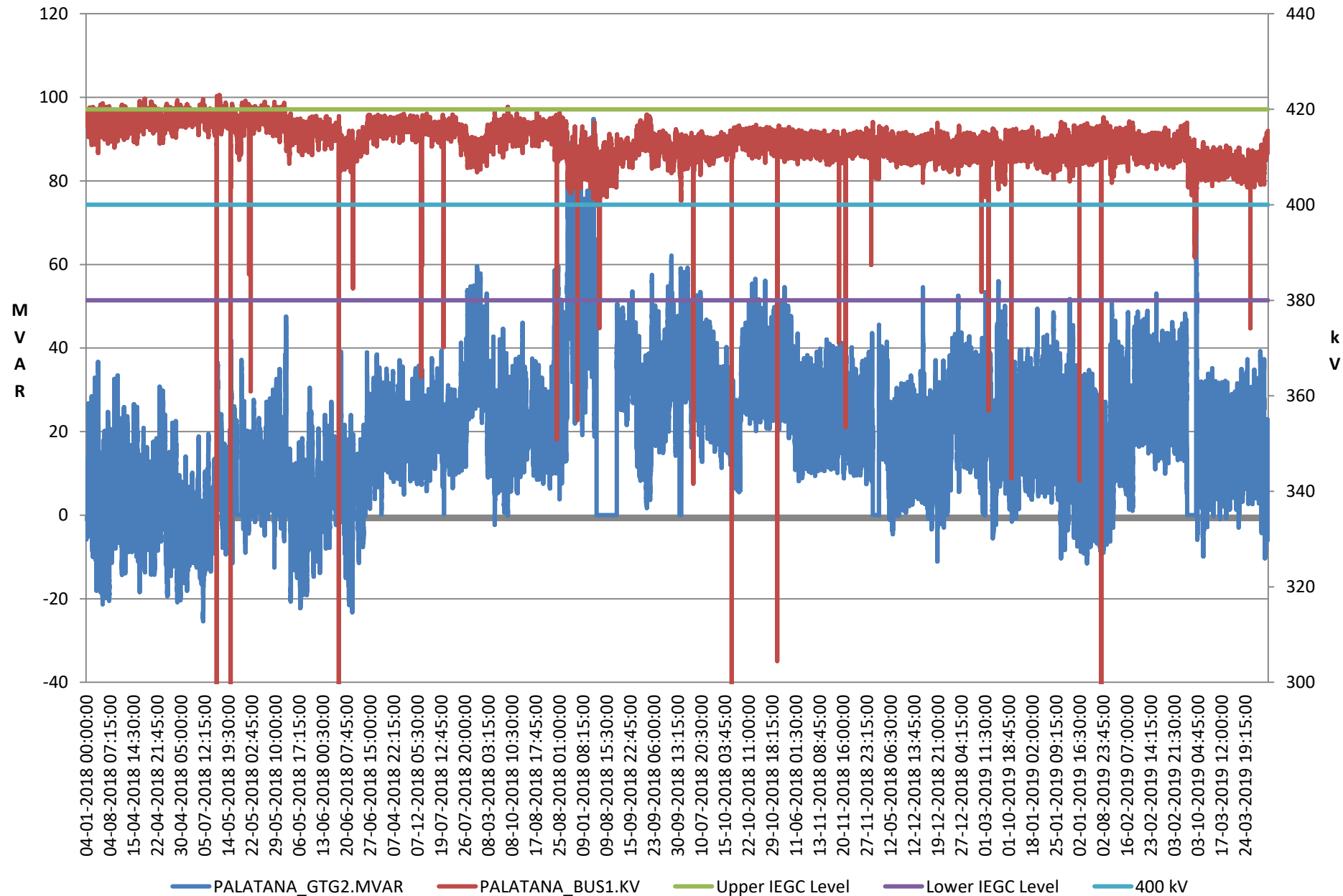

OTPC
response is
not
satisfactory ;
not absorbing
reactive
Power.

PALATANA BUS1 VOLTAGE VS STG1 MVAR

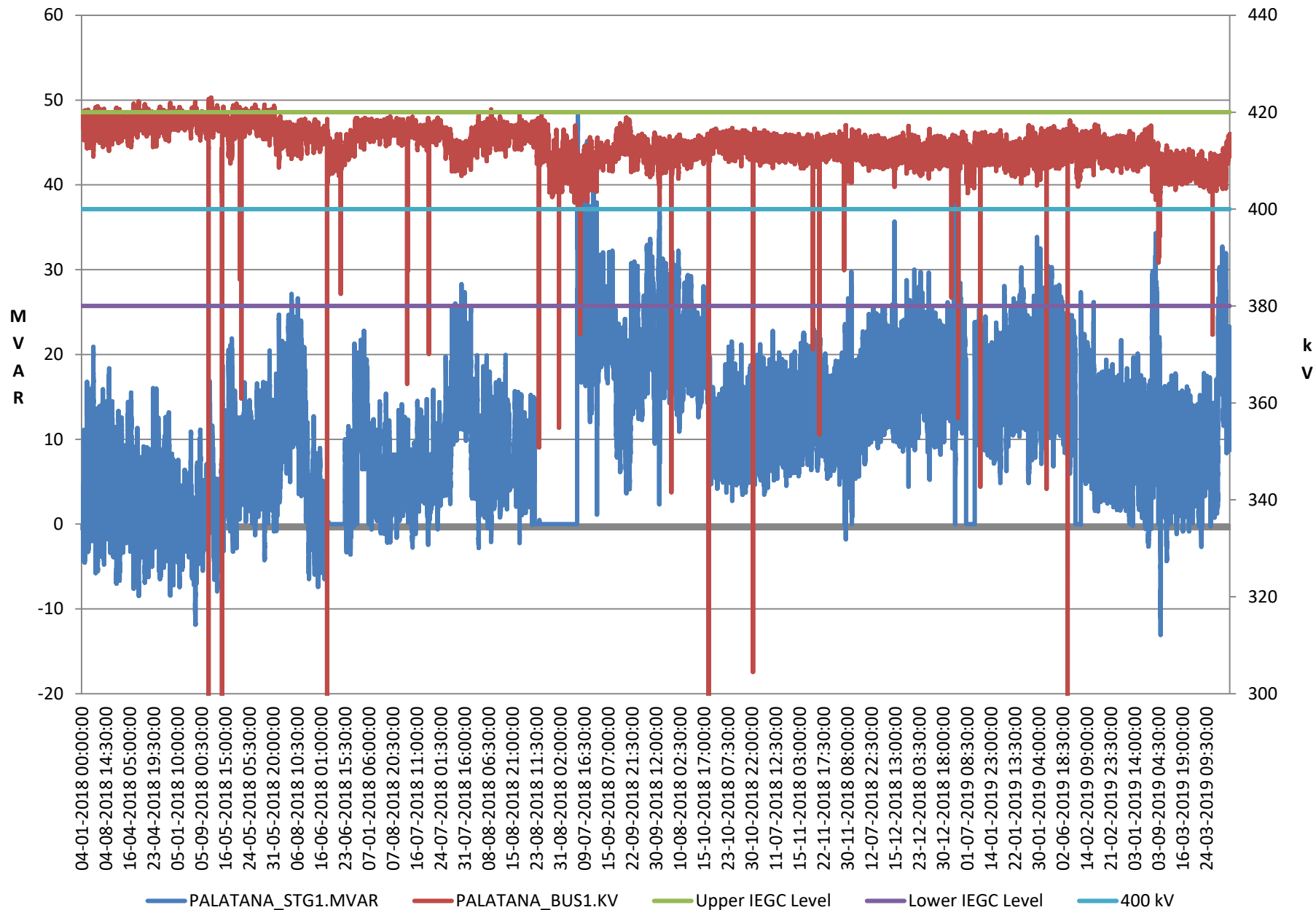

**OTPC
response is
not
satisfactory ;
not absorbing
reactive
Power.**

PALATANA BUS1 VOLTAGE VS STG2 MVAR

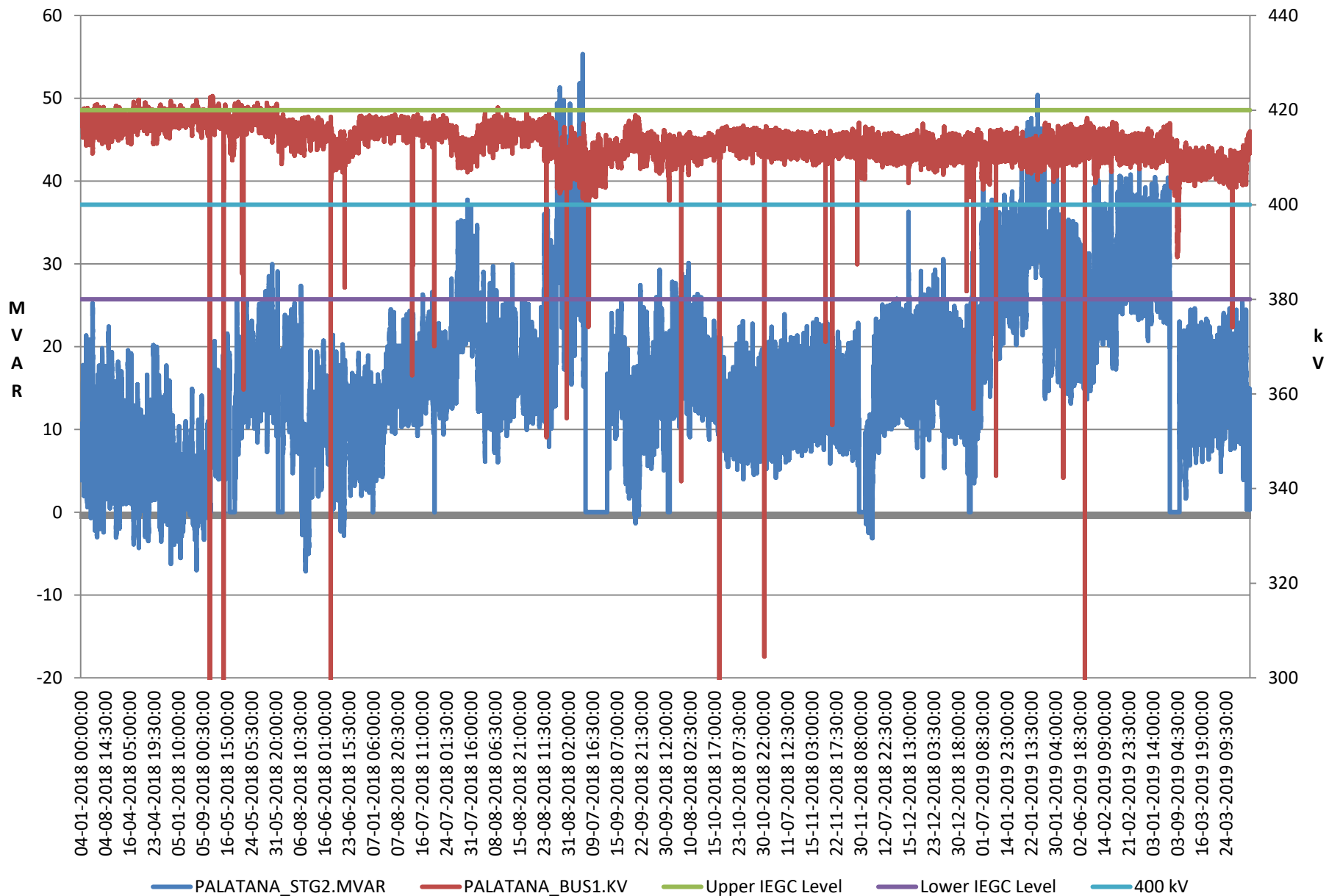

OTPC
response is
not
satisfactory ;
not absorbing
reactive
Power.

Security Constrained Economic Despatch

**Optimisation of Generation
Pilot project wef 01.04.2019**

Installed Capacity of Generators in SCED

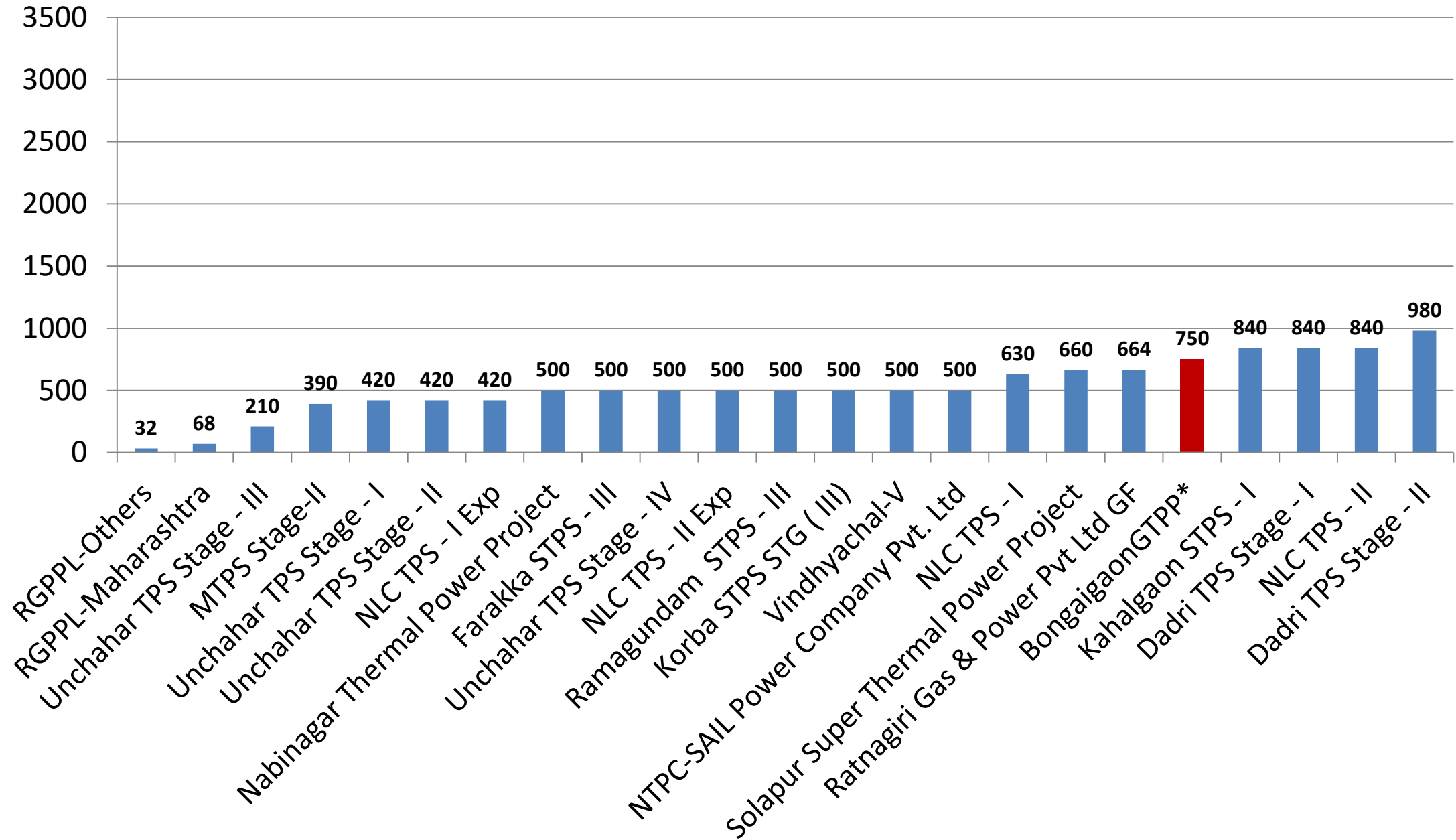

Installed Capacity of Generators in SCED

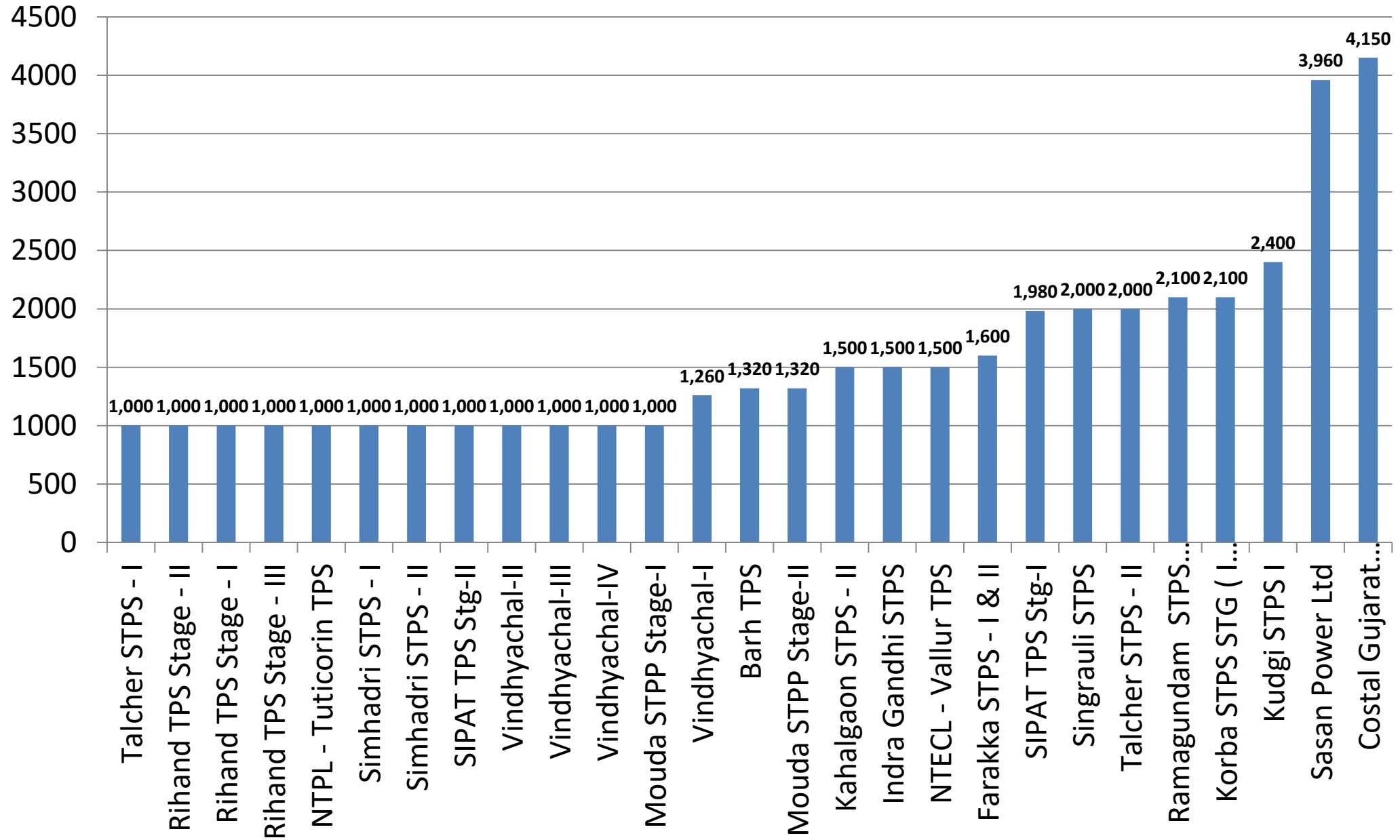

Variable cost of Generator paise/unit

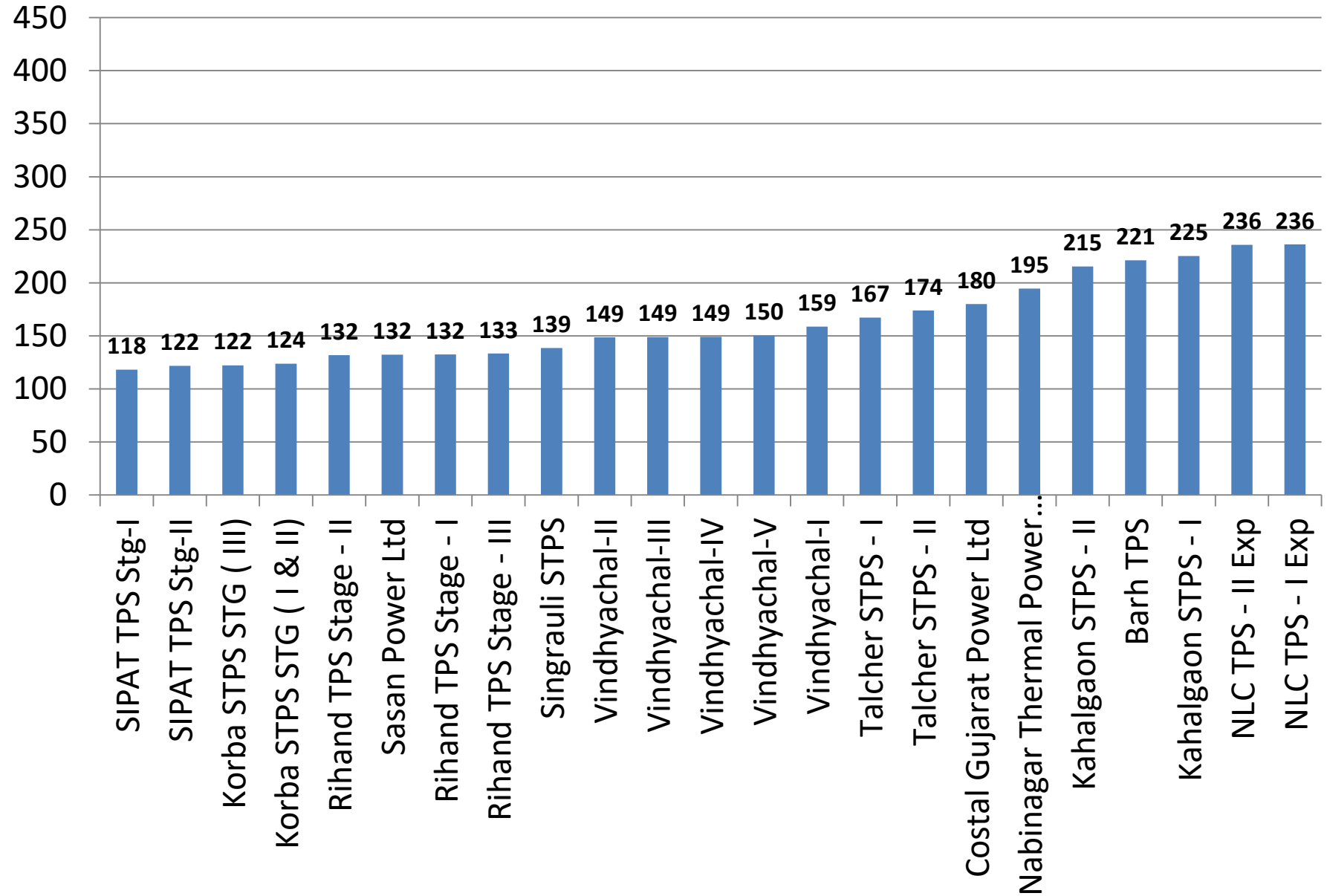

Variable cost of Generator paise/unit

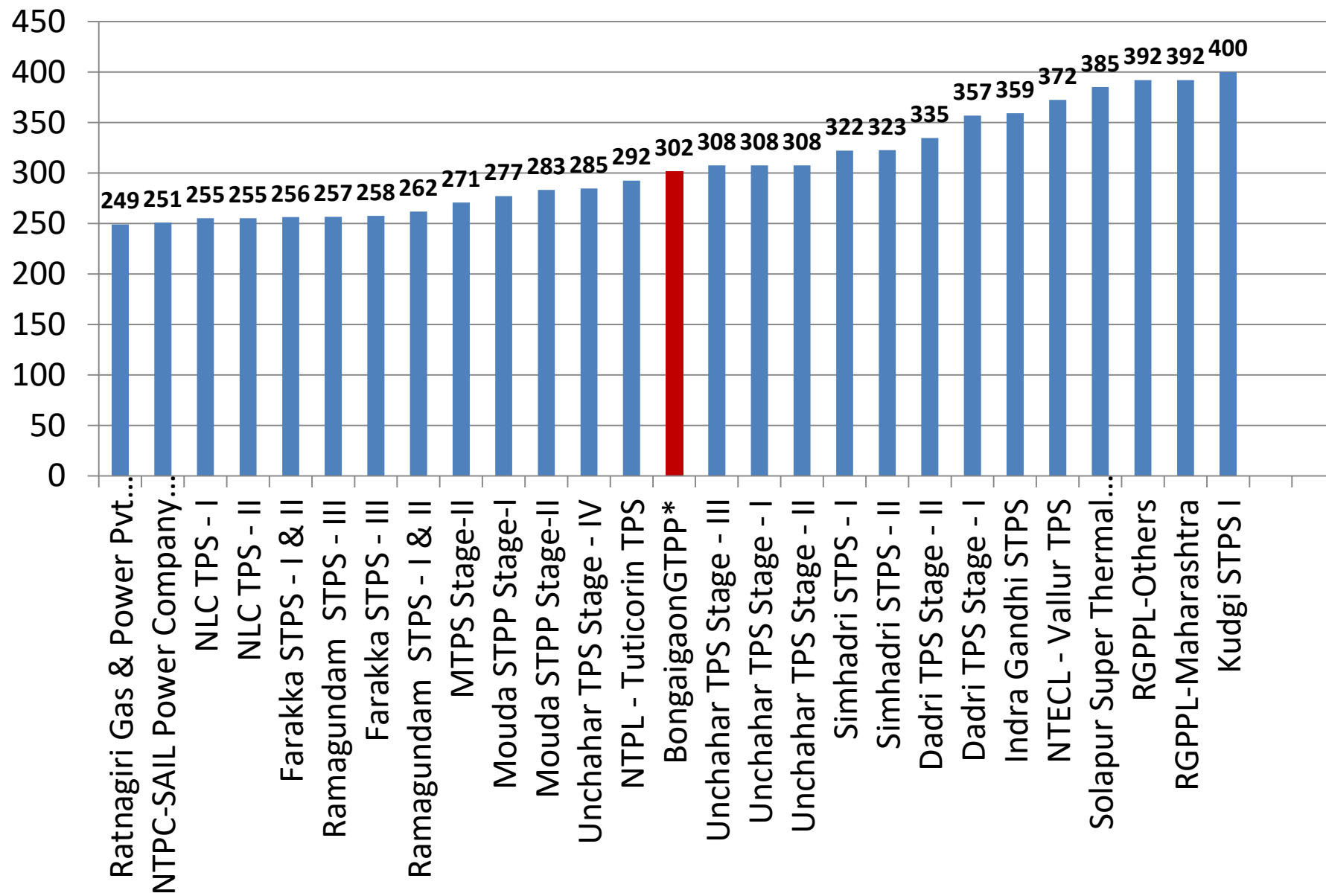

BgTPP ISGS Schedule & SCED for 03.04.2019

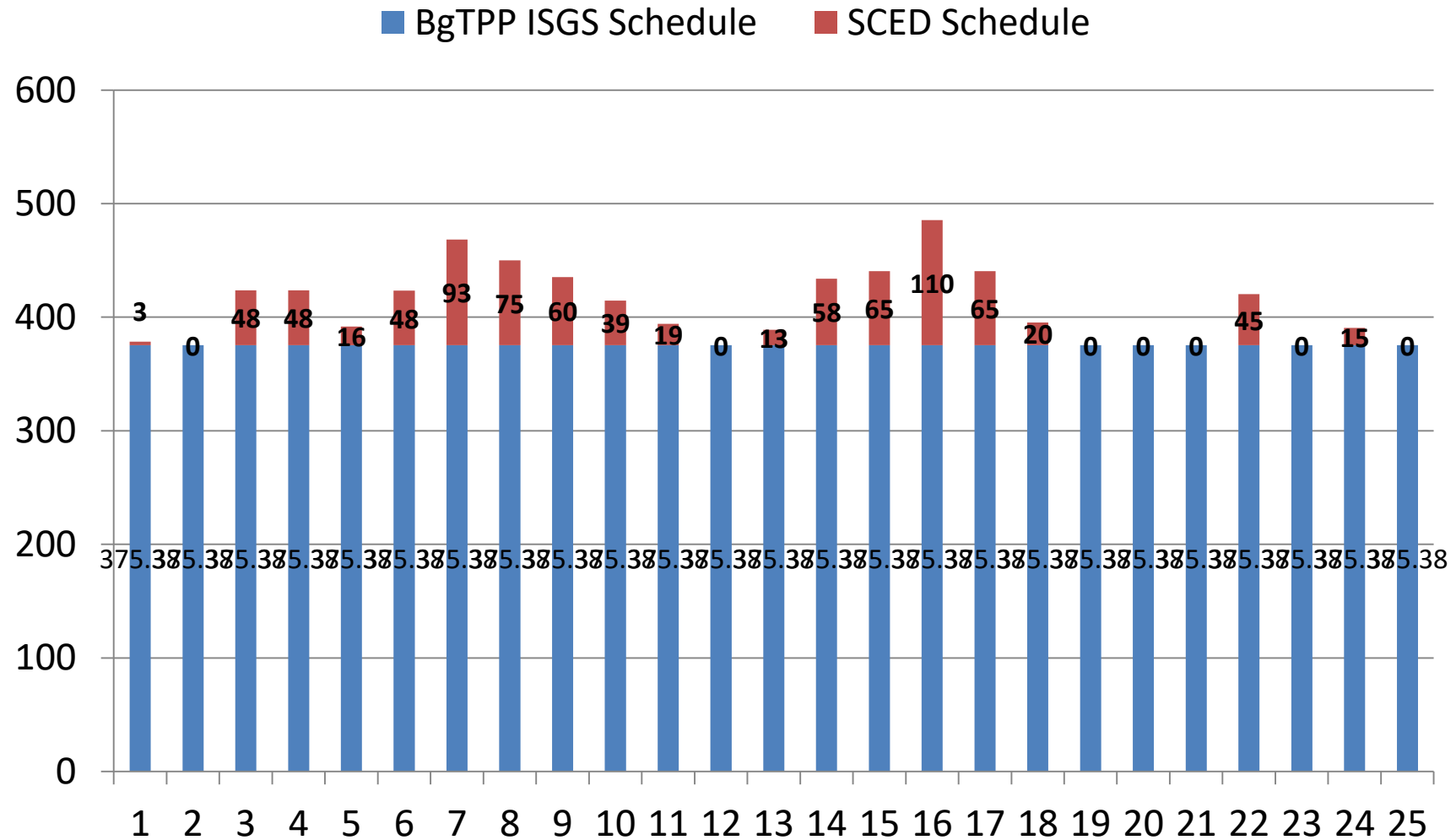

BgTPP ISGS Schedule & SCED for 03.04.2019

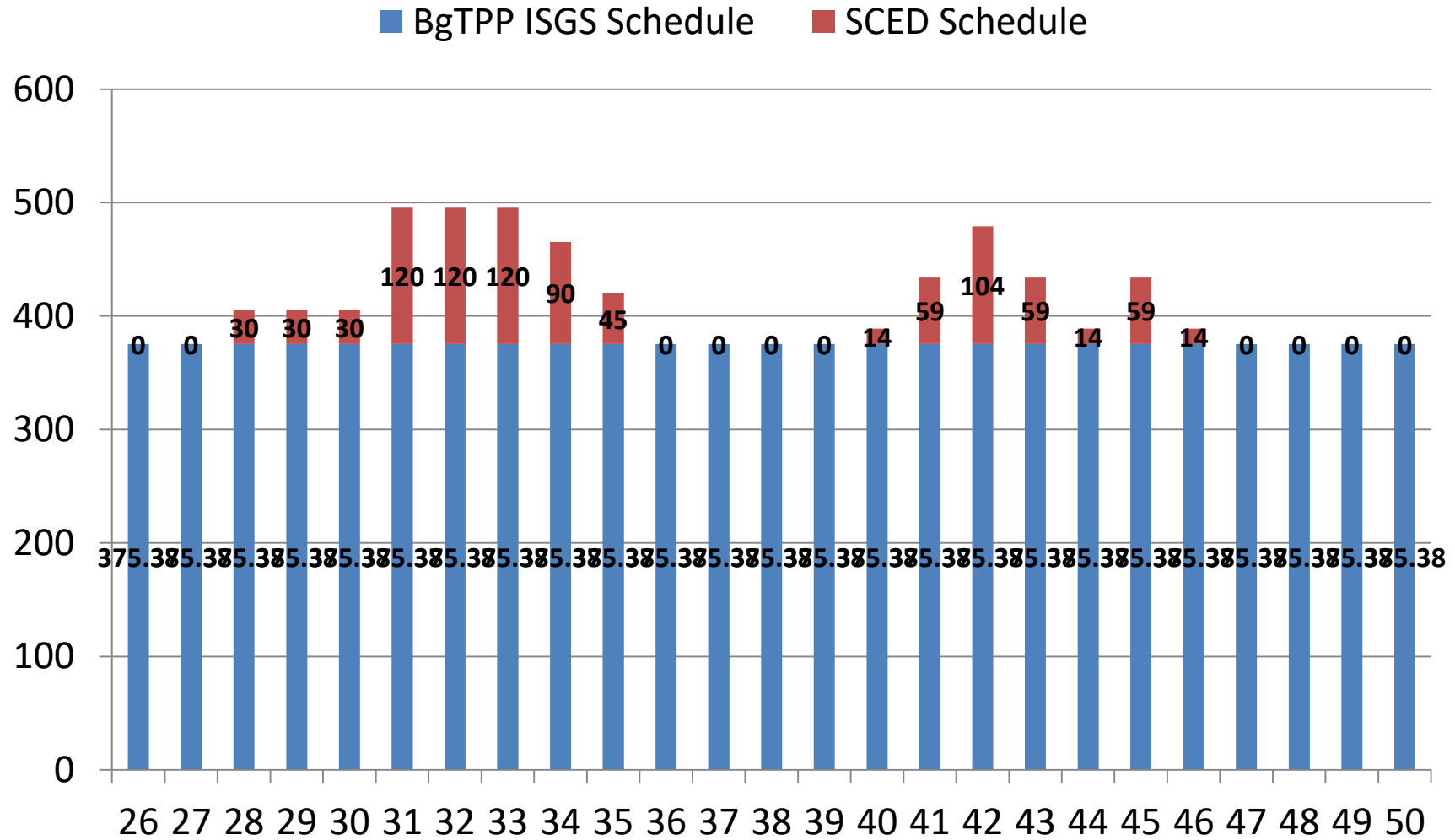

BgTPP ISGS Schedule & SCED for 03.04.2019

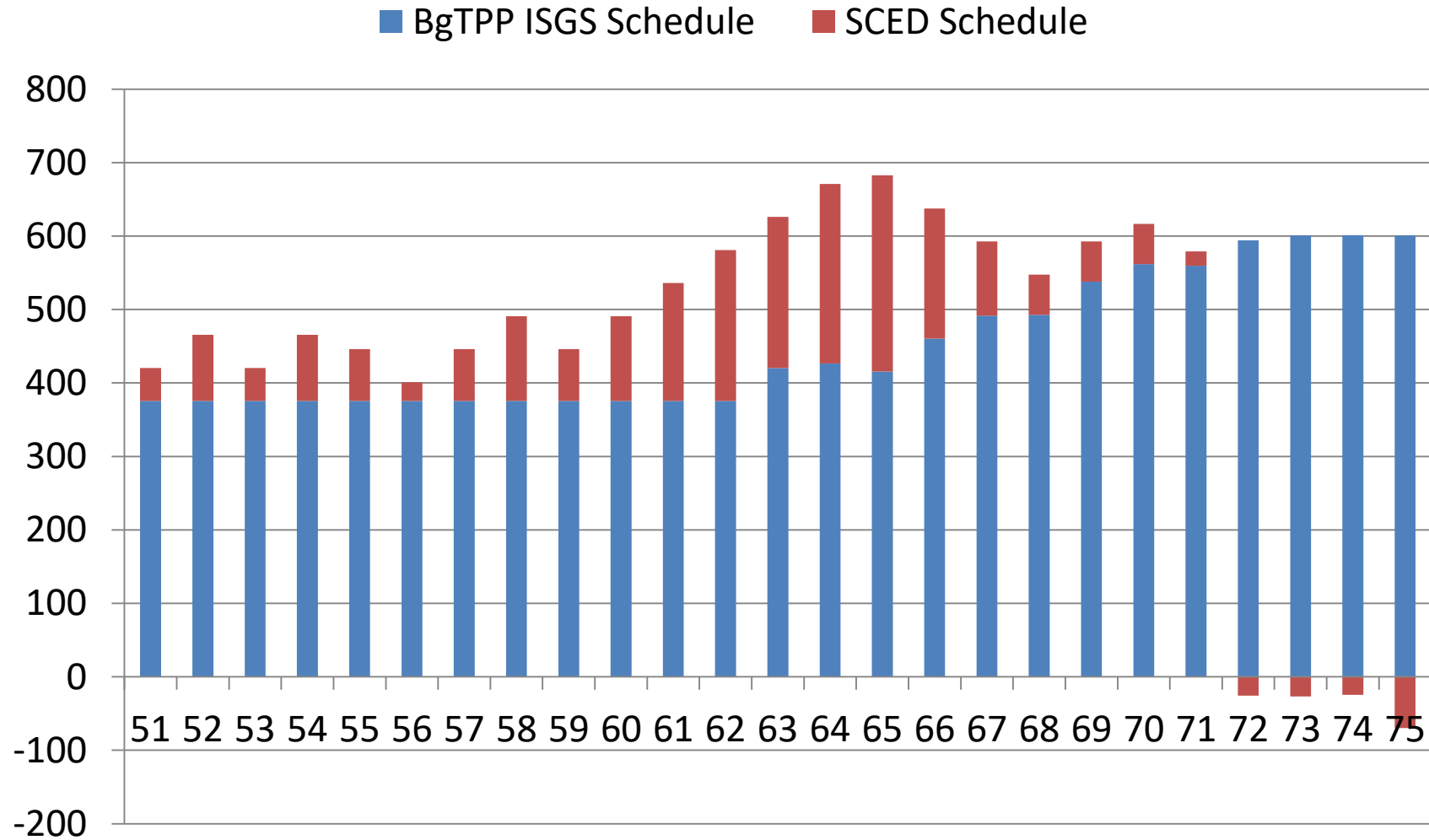

BgTPP ISGS Schedule & SCED for 03.04.2019

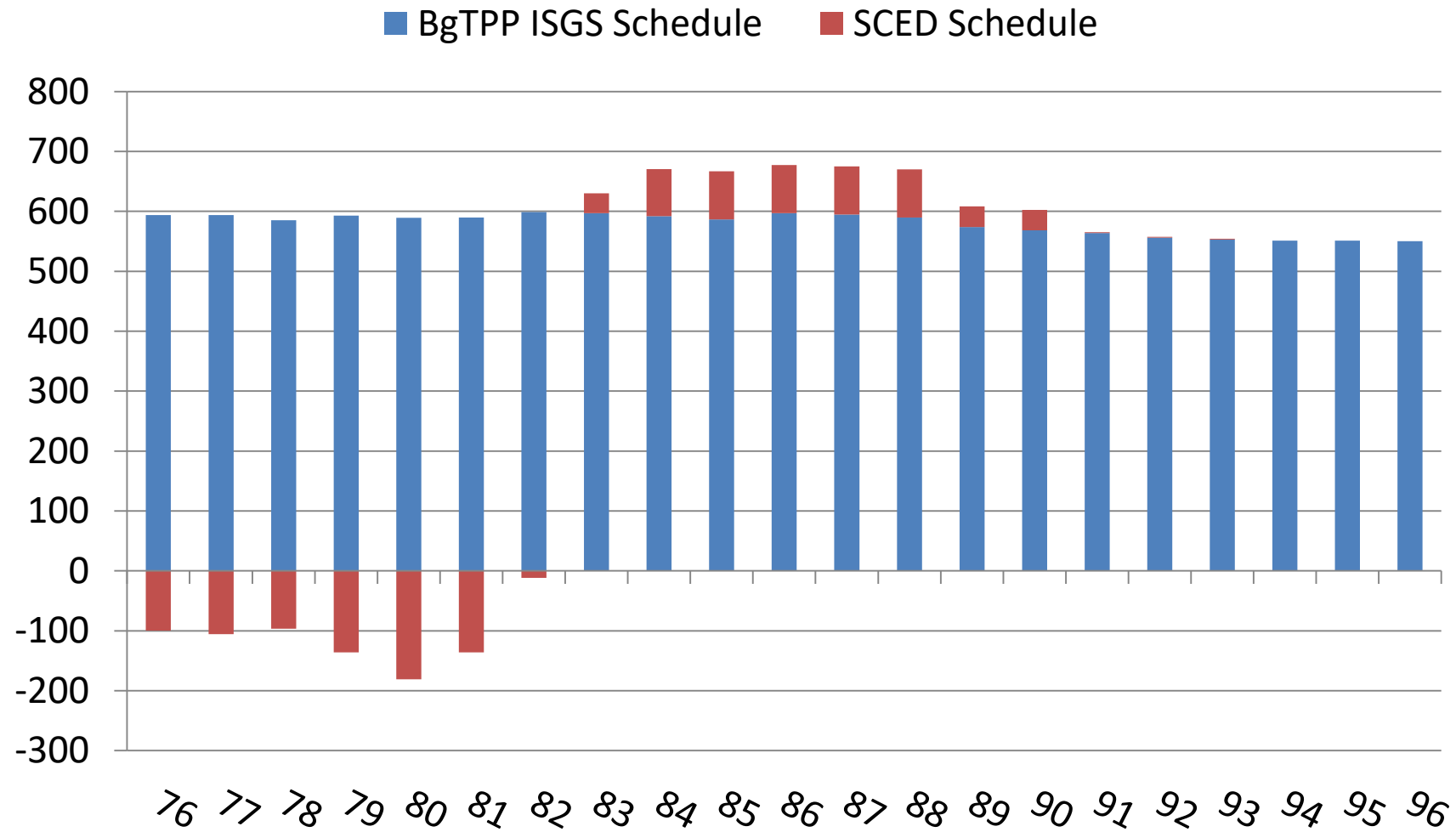

THANK YOU

पावर सिस्टम ऑपरेशन करपोरेशन लिमिटेड
(भारत सरकार का उद्यम)
POWER SYSTEM OPERATION CORPORATION LIMITED
(A Government of India Enterprise)



उत्तर पूर्वी क्षेत्रीय भार प्रेषण केंद्र : लोअर नंगरा, लापालांग, शिलांग-793006, (मेघालय)
North Eastern Regional Load Despatch Centre: Lower Nongrah, Lapalang, Shillong - 793006, (Meghalaya)
Ph : 0364-2537470, 2537427, Fax - 2537486 Website : www.nerlhc.org, Email - nerlhc@posoco.in, CIN : U40105DL2009GOI188682

संदर्भ/Ref: NERLDC/SO-I/OTPC/2019/

दिनांक/Date :01-04-2019

To,
The Head of the Project,
OTPC Power Plant
Udaipur-Kakraban Road, Palatana P.O.,
District Gomati, Tripura-799105

विषय/SUB: Non absorption of MVAR by all units of OTPC Palatana

Sir,

It has been observed that all the units of OTPC Palatana are unable to absorb MVAR and they have been observed to be in MVAR generation mode at almost all the times. Plots on MVAR generation/absorption of all the units pertaining to last one week along with the respective bus voltage have been attached as Annexure to this letter.

In this context, you are requested to kindly regulate the MVAR flow such that MVAR is absorbed by the units during high voltage condition in the Palatana Bus and MVAR is generated by the units during low voltage condition.

This is for further necessary action at your end please.

Yours sincerely,

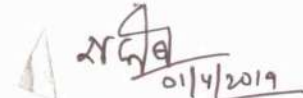

01/4/2019
(आर. सूत्रधार /R. Sutradhar)

Copy To:

1) सदस्य सचिव, उपक्षेत्रीय/ MS, NERPC

व. महाप्रबंधक (एस.ओ-1)/Sr. GM (S.O-1)

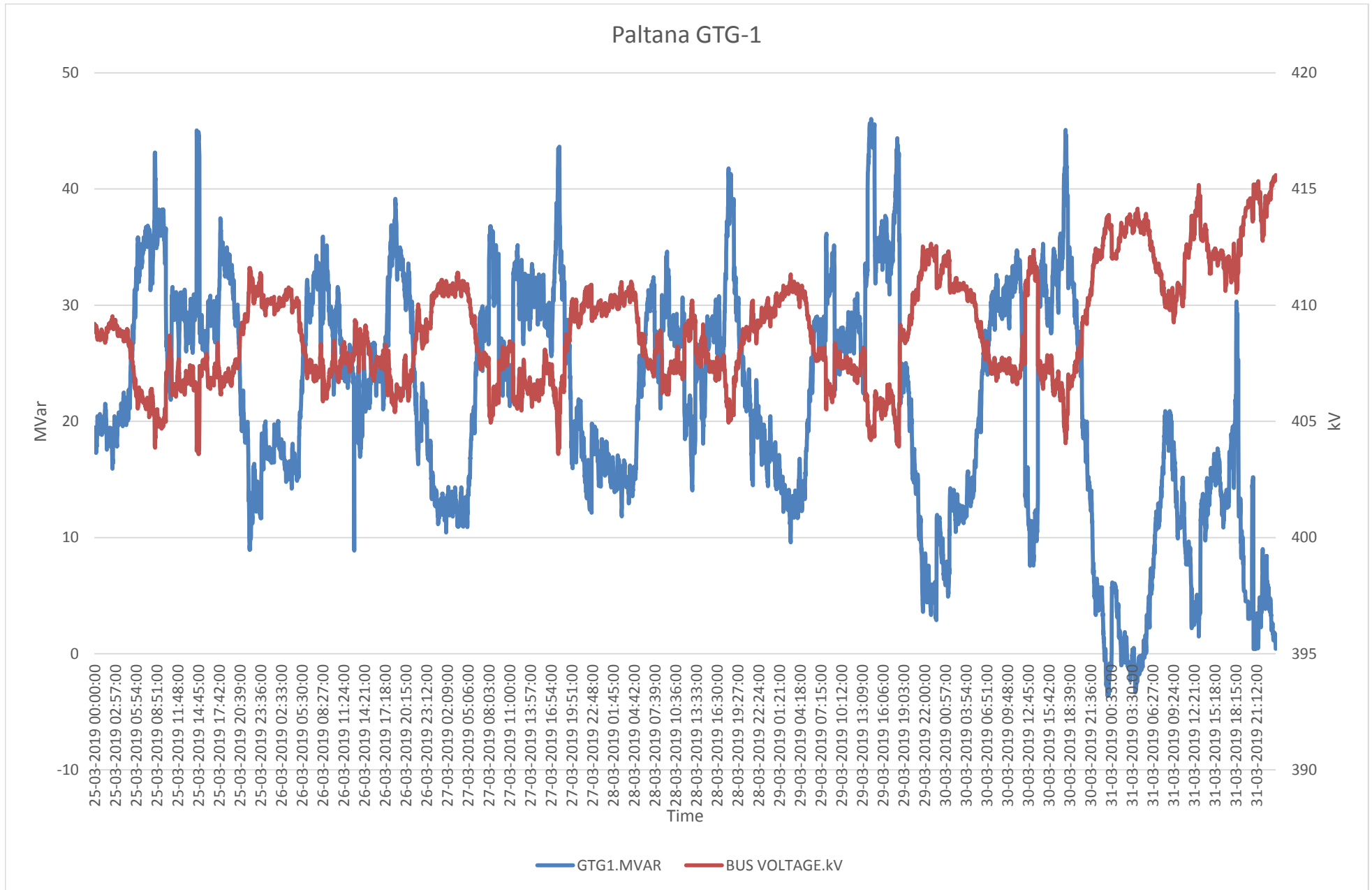
उ.पू.क्षे.भा.प्रे.के/NERLDC.



Paltana STG-1

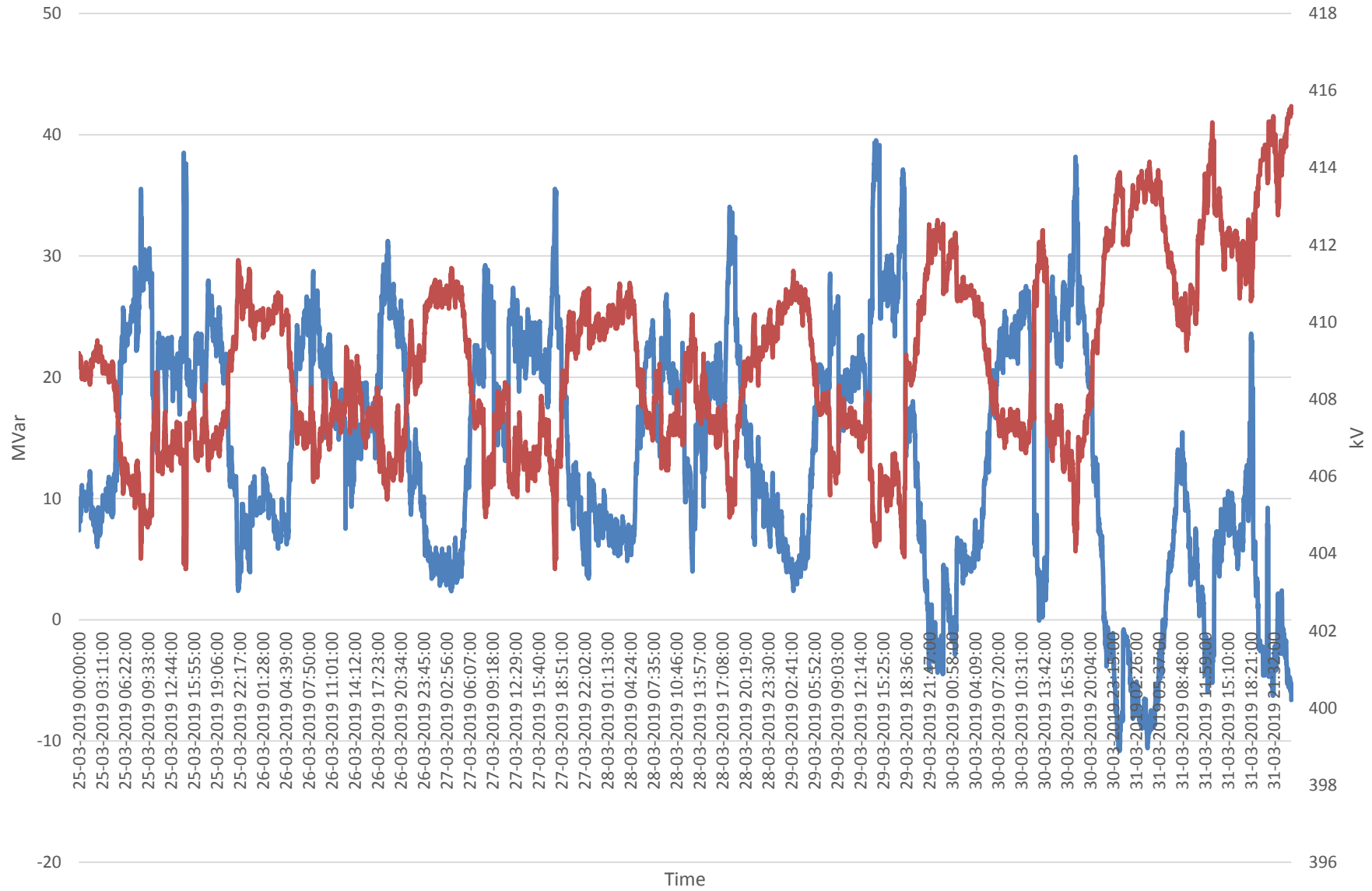

— STG1.MVAR — BUS VOLTAGE.kV

Palatana GTG-2

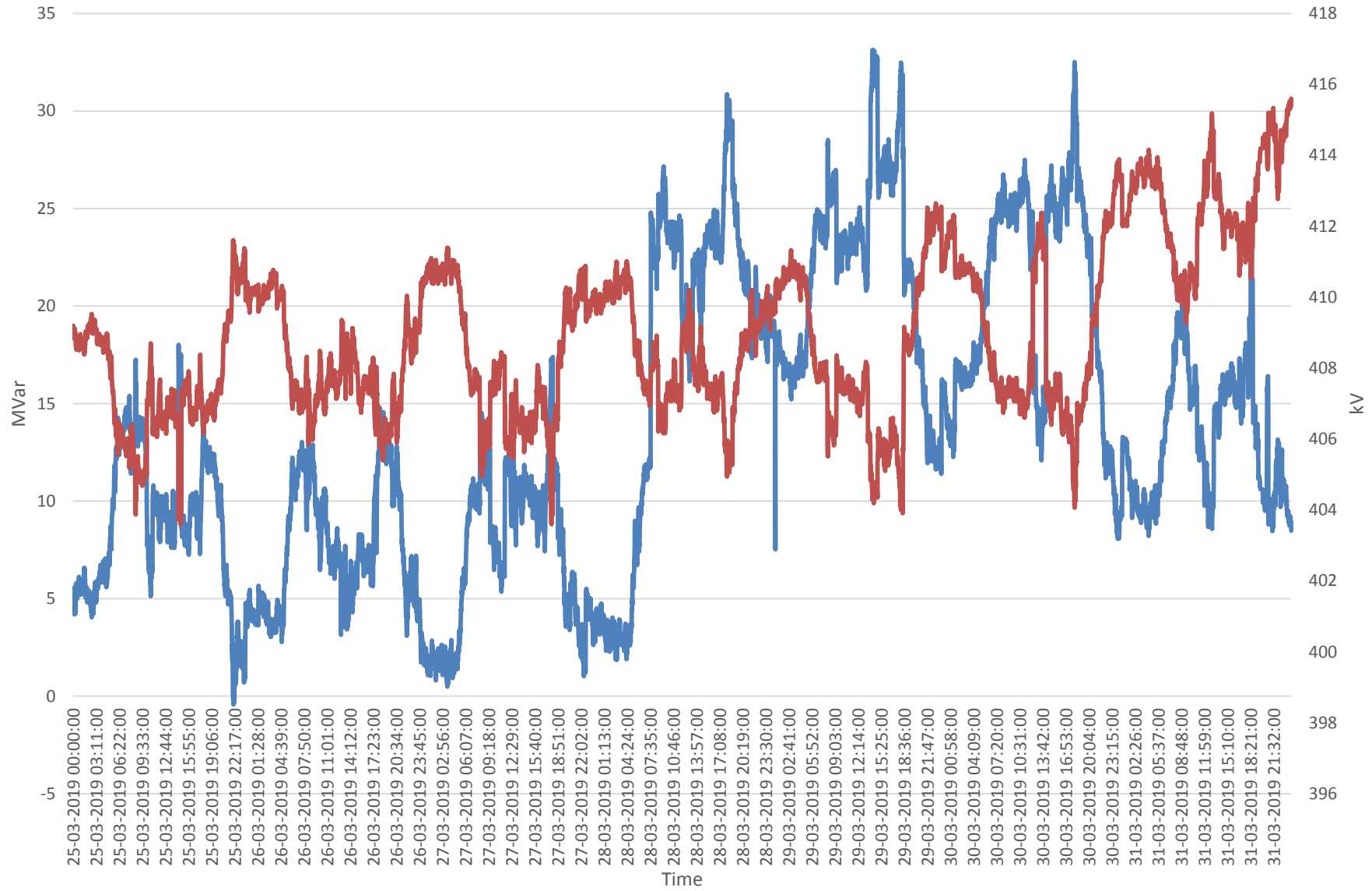

GTG2.MVAR BUS VOLTAGE.kV

Palatana STG-2

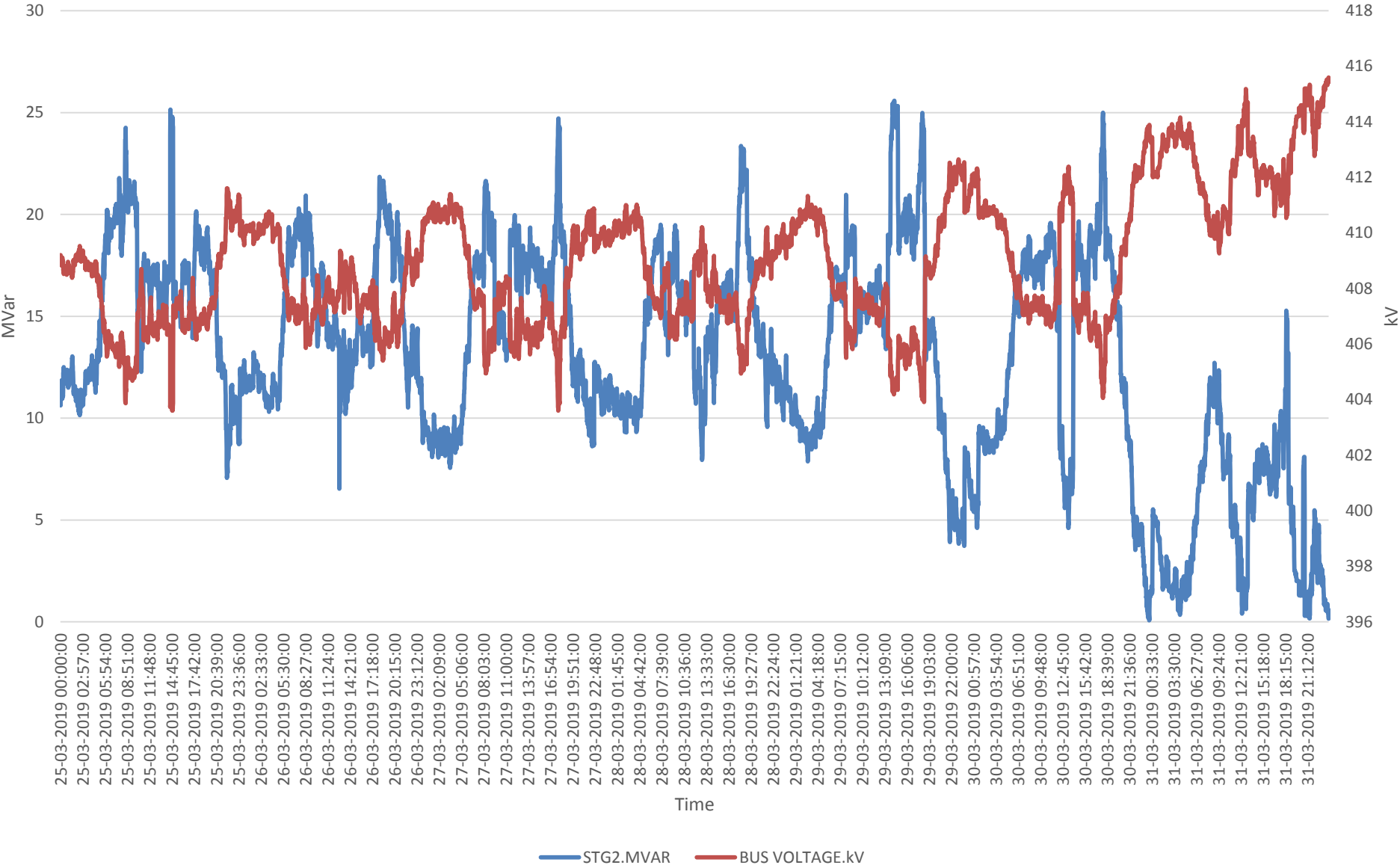

ANNEXURE- IV

SL.NO	PGCIL	STATUS
1	BNC (PG)	REPORT NOT RECEIVED
2	BADARPUR (PG)	REPORT NOT RECEIVED
3	Silchar(PG)	REPORT NOT RECEIVED
4	MARIANI (PG)	REPORT NOT RECEIVED
5	HAFLONG (PG)	REPORT NOT RECEIVED
6	Mokokchang(PG)	REPORT NOT RECEIVED
7	RANGIA (PG)	REPORT NOT RECEIVED
8	Melriat(pg)	REPORT NOT RECEIVED
9	Aizawl(pg)	REPORT NOT RECEIVED
10	Ziro(pg)	REPORT NOT RECEIVED
11	Misa(pg)	REPORT NOT RECEIVED
	ASSAM	
12	DULLAVCHERRA	REPORT NOT RECEIVED
13	SARUSAJAI	REPORT NOT RECEIVED
14	TINSHUKIA	REPORT NOT RECEIVED
15	NAGALAND(S)	REPORT NOT RECEIVED
16	MIZORAM(S)	REPORT NOT RECEIVED
	TRIPURA	
17	UDAIPUR	REPORT NOT RECEIVED
18	P.K BARI	REPORT NOT RECEIVED
19	79 TILLA	IRREGULAR
	MANIPUR	
20	NINGTHOKONG	REPORT NOT RECEIVED
21	RENGPANG	REPORT NOT RECEIVED
22	KARONG	REPORT NOT RECEIVED
23	YUREMBAM	REPORT NOT RECEIVED
	MEGHALAYA	
24	UMTRU	IRREGULAR
25	BYRNIHAT	REPORT NOT RECEIVED
	ARUNACHAL PRADESH	
26	CHIMPU	REPORT NOT RECEIVED
	GENERATION	
27	DOYANG	REPORT NOT RECEIVED
28	AGBPP	REPORT NOT RECEIVED
29	PARE	REPORT NOT RECEIVED
30	RHEP	REPORT NOT RECEIVED
31	PALATANA	IRREGULAR
32	KHANDONG	IRREGULAR

RGMO Analysis for event dated 12.03.2019

On 12-March-2019 at 13:02 Hrs, HVDC talcher-Kolar pole 2 tripped due to DC earth fault . The SPS associated with HVDC Talcher-kolar pole tripping operated and led to load relief of approx 1219 MW in southern region. The frequency change was 0.08 Hz.

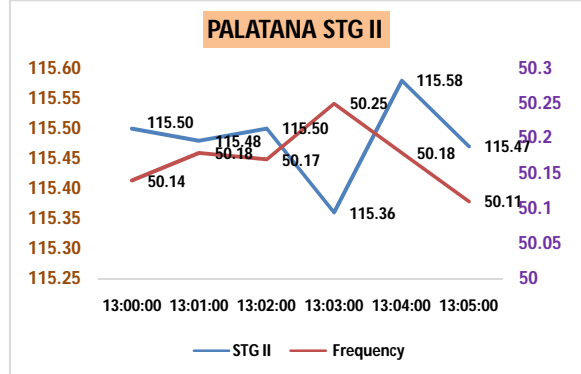
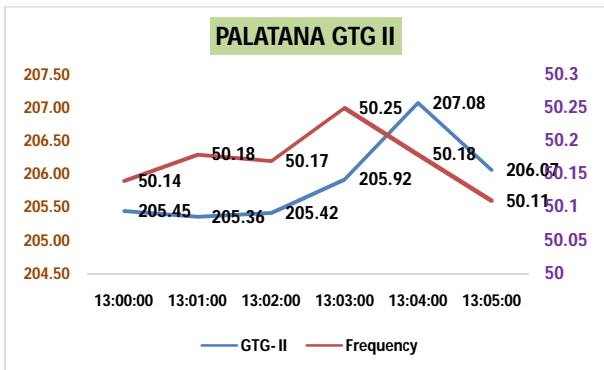
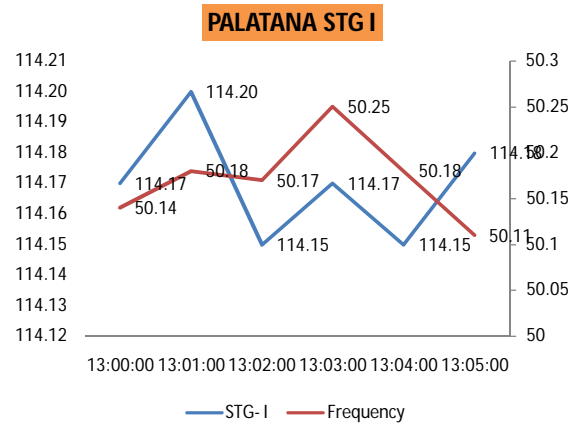
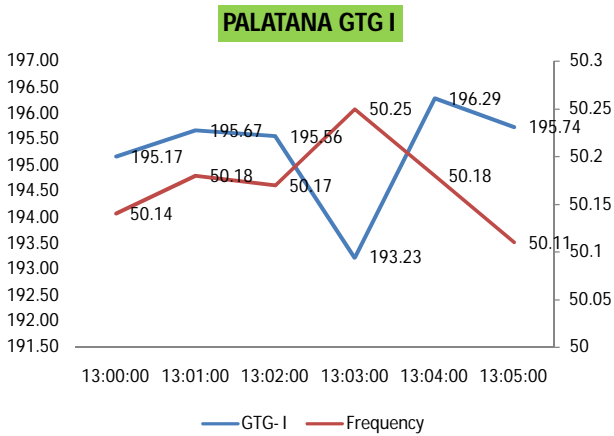

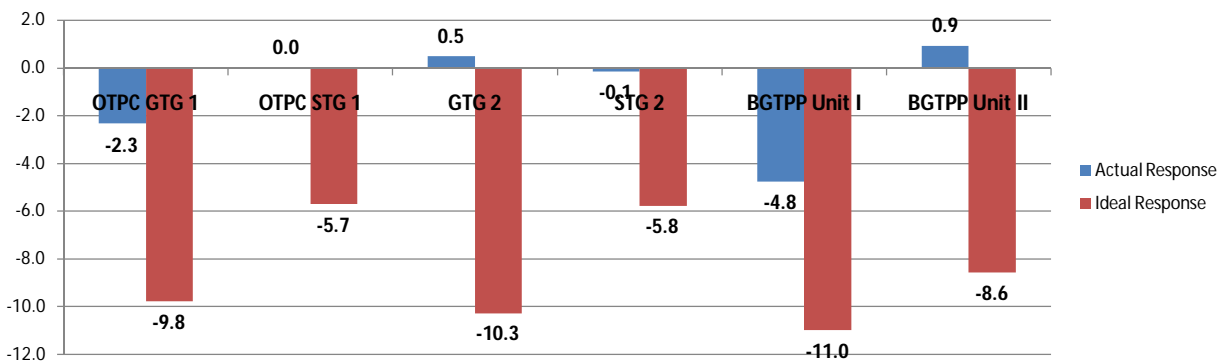
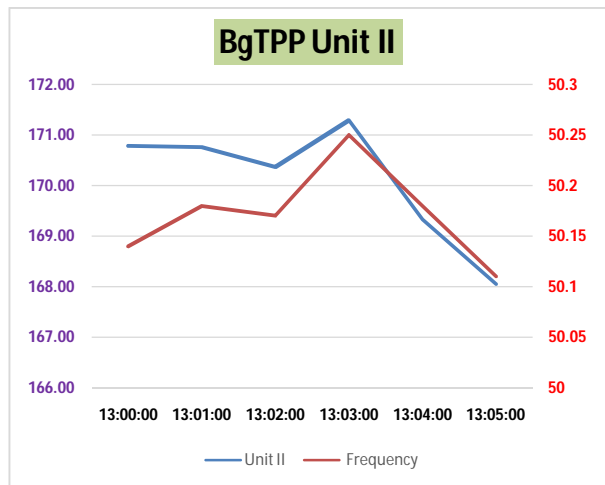
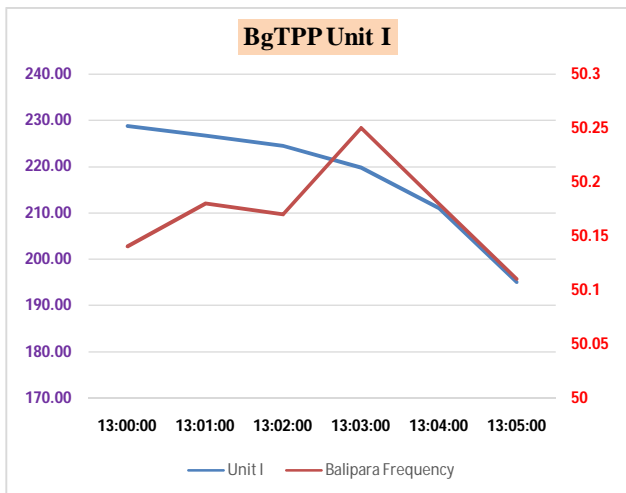

Grid Disturbance in NER dated 03.04.2019

Pre Disturbance Grid Scenario:

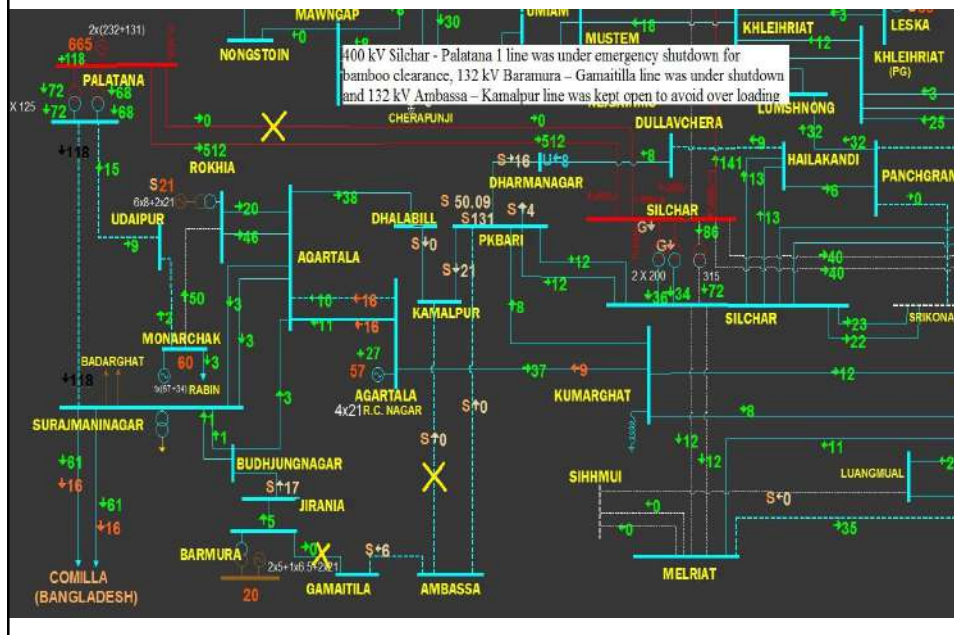

• **Sequence of events:**

(i) Tripping of 400 kV Silchar – Palatana II

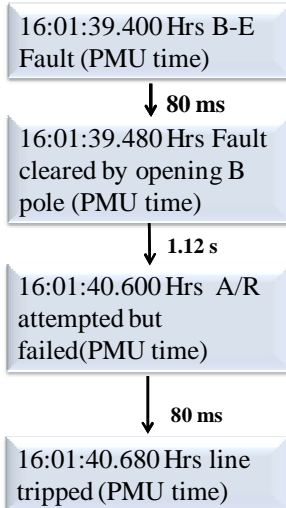

(ii) Operation of SPS 2

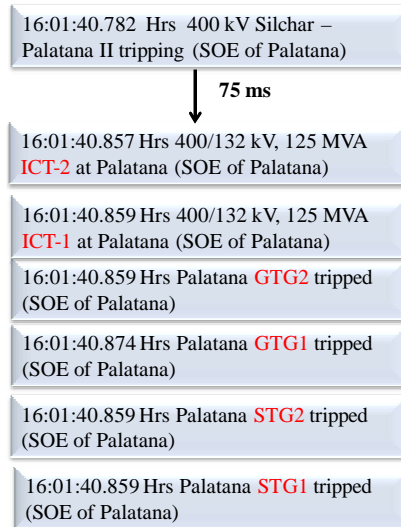

(iii) Trippings in Tripura/Palatana zone :

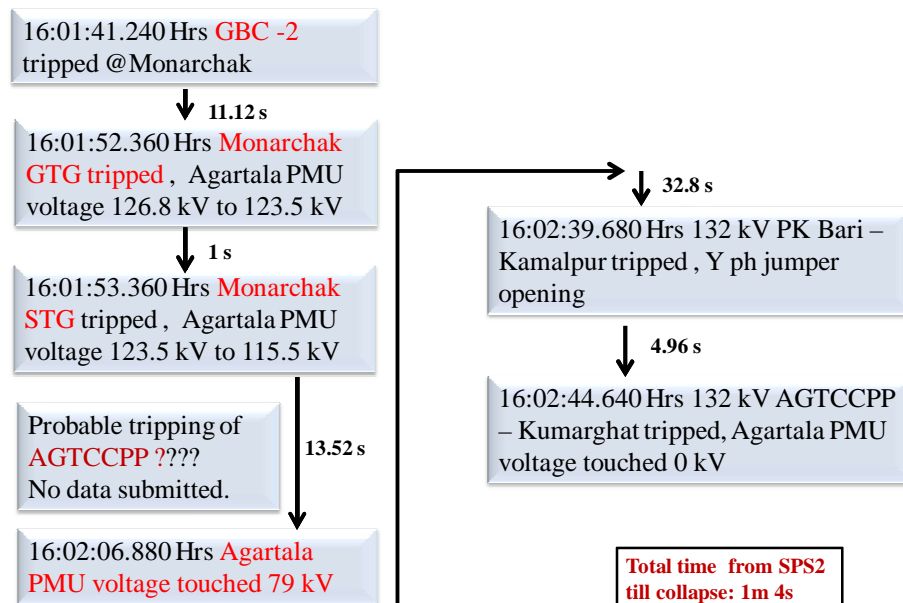

Total time from SPS2 till collapse: 1m 4s

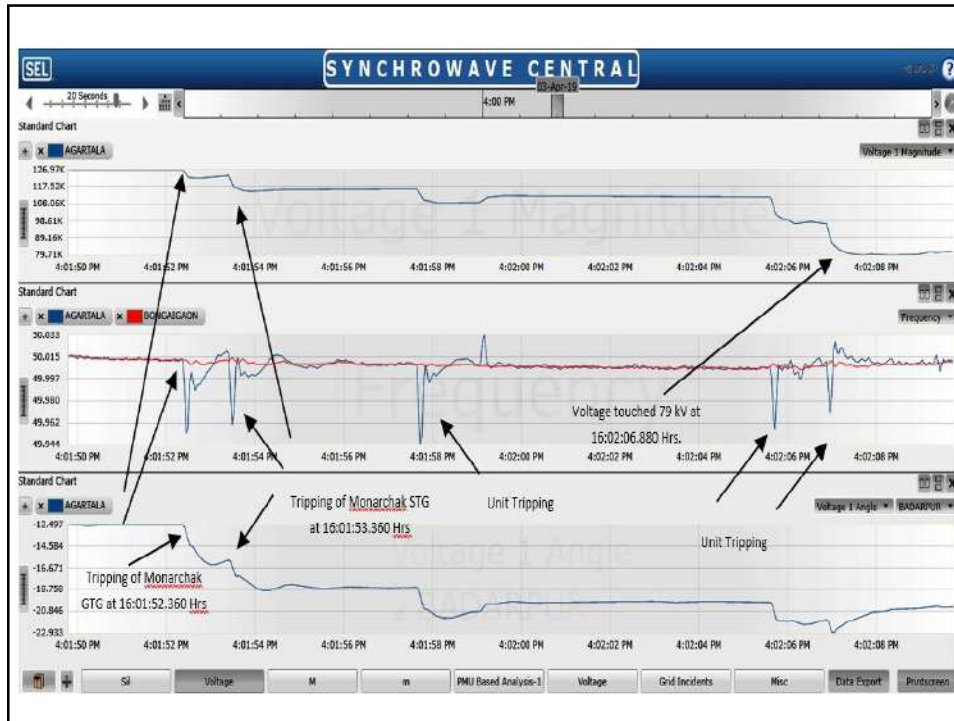

• Sequence of events (time mismatch):

SlNo	Elements (End 1 – End 2)	Tripping Time (DR) End 1	Tripping Time (DR) End 2	Tripping Time (SOE at NERLDC) End 1	Tripping Time (SOE at NERLDC) End 2	Tripping Time (PMU)	Timing of SoE submitted by utilities	Relay Indication at End 1	Relay indication at End 2
01	400 kV Palatana-Silchar-II Line	16:01:40.72 Hrs	16:01:39.48 Hrs	16:01:41.77 Hrs	16:01:39.53 Hrs	16:01:40.68 0 Hrs	Palatana: 16:01:40.782 Hrs; Silchar: Not submitted	DP, Z-II, B-E, 227.30 Kms, Carrier received	DP, Z-1, B-E, F 22.00 Kms.
02	400/132 kV, 125 MVA ICT-1 at Palatana	Not submitted#		16:01:41.016 Hrs (Opening of HV CB)		-	Tie CB: 16:01:40.859 Hrs; Main CB status-not available	SPS-2 operated	
03	400/132 kV 125 MVA ICT-2 at Palatana	Not submitted#		16:01:41.016 Hrs (Opening of HV CB)		-	16:01:40.857 Hrs	SPS-2 operated	
04	GTG-1 at Palatana	16:01:40.890 Hrs		16:01:41.016 Hrs (Opening of Field CB)		-	16:01:40.874 Hrs	Over frequency	
05	GTG-2 at Palatana	16:01:32.428 Hrs		16:01:41.016 Hrs (Opening of Field CB)		-	16:01:40.859 Hrs	Over frequency	
06	STG-1	16:02:40.868 Hrs		16:01:41.016 Hrs (Opening of Field CB)		-	16:01:40.859 Hrs	Trip on GTG	
07	STG-2	16:02:40.875 Hrs		16:01:41.016 Hrs (Opening of Field CB)		-	16:01:40.859 Hrs	Trip on GTG	

• Sequence of events (time mismatch):

SlNo	Elements (End 1 – End 2)	Tripping Time (DR) End 1	Tripping Time (DR) End 2	Tripping Time (SOE at NERLDC) End 1	Tripping Time (SOE at NERLDC) End 2	Tripping Time (PMU)	Timing of SoE submitted by utilities	Relay Indication at End 1	Relay indication at End 2
08	Monarchak GTG	16:01:52.42 Hrs		Not Available*		16:01:52. 360	16:01:52.327 Hrs	Tripped on Gas Booster Compressor#2	
09	Monarchak STG	16:01:55.88 Hrs		Not Available*		16:01:53. 360	16:01:53.349 Hrs	Due to tripping of GTG	
10	AGTCCPP Unit-1	DR not submitted		16:01:41.12 Hrs		-	Not submitted	Detailed report required*	
11	AGTCCPP Unit-2	DR not submitted		16:01:40.97 Hrs		-	Not submitted	Detailed report required*	
12	AGTCCPP STG-1	DR not submitted		Not Available*		-	Not submitted	Detailed report required*	
13	132 kV PK Bari- Kamalpur line	16:03:56.342 Hrs		Not Available *	Not Availabl e*	16:02:39. 680 Hrs	Not submitted	D/P, Z-I, Y-E, 16 Kms.	Broken conductor
14	132 kV Kumarghat- AGTCCPP line	16:07:07.38 Hrs	-	16:03:07 Hrs	-	16:02:44. 640 Hrs	Not submitted	Over current	No tripping

Questions:

- SOE, DR and PMU timings are different. Unless sequence of events are properly constructed, analysis will not be conclusive.

Action: Utilities needs to go for time sync.

- AGTCCPP has not submitted DR yet. Action: To be submitted within 24 hours.
- In the present situation, defence mechanism needs a re-look. Trippings of Monarchak, AGTCCPP generators are not substantiated. Tripping of Generators caused voltage dip and further resulted in isolation/collapse. Action: Investigation and remedy.
- SPS – 2 envisages FSNL of PALATANA which did not happen. What is the percentage probability of FSNL?

Questions:

- SPS – 1 operated partially, 132 kV Silchar – Srikona II & 132 kV Silchar – Hailakandi D/C did not tripped. **Action: Check by CTU.**
- Palatana-Silchar line SIL 515 MW, mid span failure at a loading of SIL raises questions; need thorough checking to avoid restriction in loading.
- TSECL need to specify loading limit of 132 kV PK Bari-Dhalabil-Kamalpur-Agartala line.
- Information to all SLDCs about emergency S/D: **Action: NERLDC to provide information.**