



भारत सरकार Government of India

विद्युत मंत्रालय Ministry of Power

उत्तर पूर्वी क्षेत्रीय विद्युत समिति

North Eastern Regional Power Committee

एन ई आर पी सी कॉम्प्लेक्स, डोंग पारमाओ, लापालाङ, शिल्लोंग-७९३००६, मेघालय
NERPC Complex, Dong Parmaw, Lapalang, Shillong - 793006, Meghalaya

Ph. No: 0364 - 2534039

Fax No: 0364 - 2534040

Website: www.nerpc.nic.in

No. NERPC/SE (O)/OCC/2019/ **3189-3226**

Dated: 29 March, 2019

To,

1. Managing Director, AEGCL, Bijuli Bhawan, Guwahati – 781 001
2. Managing Director, APDCL, Bijuli Bhawan, Guwahati – 781 001
3. Managing Director, APGCL, Bijuli Bhawan, Guwahati – 781 001
4. Director (Generation), Me. PGCL, Lumjingshai, Short Round Road, Shillong – 793 001
5. Director (Distribution), Me. ECL, Lumjingshai, Short Round Road, Shillong – 793 001
6. Director(Transmission), Me. PTCL, Lumjingshai, Short Round Road, Shillong – 793 001
7. Managing Director, MSPDCL, Secure Office Bldg. Complex, South Block, Imphal – 795 001
8. Managing Director, MSPCL, Electricity Complex, Keishampat, Imphal – 795 001
9. Director (Tech.), TSECL, Banamalipur, Agartala -799 001.
10. Director (Generation), TPGCL, Banamalipur, Agartala -799 001.
11. Chief Engineer (WE Zone), Department of Power, Govt. of Arunachal Pradesh, Itanagar- 791111
12. Chief Engineer (EE Zone), Department of Power, Govt. of Arunachal Pradesh, Itanagar- 791111
13. Chief Engineer (TP&MZ), Department of Power, Govt. of Arunachal Pradesh, Itanagar- 791111
14. Engineer-in-Chief (P&E), Department of Power, Govt. of Mizoram, Aizawl – 796 001
15. Chief Engineer (P), Department of Power, Govt. of Nagaland, Kohima – 797 001
16. CGM, (LDC), SLDC Complex, AEGCL, Kahilipara, Guwahati-781 019
17. Group General Manager, NTPC, Bongaigoan Thermal Power Project, P.O. Salakati, Kokrajhar- 783369
18. ED, NERTS, PGCIL, Dongtiah-Lower Nongrah, Lapalang, Shillong -793 006
19. ED (O&M), NEEPCO Ltd., Brookland Compound, Lower New Colony, Shillong-793003
20. ED (Commercial), NEEPCO Ltd., Brookland Compound, Lower New Colony, Shillong-793003
21. ED (O&M), NHPC, NHPC Office Complex, Sector-33, Faridabad, Haryana-121003
22. Vice President (Plant), OTPC, Badarghat Complex, Agartala, Tripura - 799014
23. GM, NERLDC, Dongtiah, Lower Nongrah, Lapalang, Shillong -793 006
24. Member Secretary, ERPC, 14 Golf Club Road, Tollygunge, Kolkata-700033
25. Chief Engineer, GM Division, Central Electricity Authority, New Delhi – 110066
26. Chief Engineer (NPC), NRPC Complex, Katwaria Sarai, SJSS Marg., New Delhi - 110016

Sub: Minutes of 154th OCC Meeting.

Sir/Madam,

Please find enclosed herewith the minutes of 154th OCC Meeting held at Guwahati on the **13th March, 2019** for your kind information and necessary action. The minute is also available on the website of NERPC, www.nerpc.nic.in.

Any comments/observations may kindly be communicated to NERPC Secretariat at the earliest.

Encl: As above

भवदीय / Yours faithfully,

बि. लिंगखोइ / B. Lyngkhoi

निदेशक / Director/ SE

Copy to:

1. □CGM, AEGCL, Bijuli Bhavan, Guwahati - 781001
2. □CGM, APGCL, Bijuli Bhavan, Guwahati - 781001
3. □CGM, DISCOM, Bijuli Bhavan, Guwahati - 781001
4. □Head of SLDC, Me.ECL, Lumjingshai, Short Round Road, Umjarain, Shillong – 793 022
5. □Head of SLDC, Department of Power, Govt. of Arunachal Pradesh, Itanagar- 791 111
6. □Head of SLDC, Department of Power, Dimapur, Nagaland
7. □Head of SLDC, Electricity Department, Govt. of Manipur, Keishampat, Imphal – 795 001
8. □Head of SLDC, Department of Power, Govt. of Mizoram, Aizawl – 796 001
9. □Head of SLDC, TSECL, Agartala – 799 001
10. □Chief Engineer(Elect), Loktak HEP, Vidyut Vihar, Kom Keirap, Manipur- 795124
11. □Addl. GM (EED), NTPC Ltd., Bongaigoan Thermal Power Project, P.O. Salakati, Kokrajhar- 783369
12. □DGM (C&M), OTPC, 6th Floor, A-Wing, IFCI Tower -61, Nehru Place, New Delhi – 110019.



निदेशक / Director/ SE

North Eastern Regional Power Committee

MINUTES OF THE 154th OPERATION COORDINATION

SUB-COMMITTEE MEETING OF NERPC

Date : 13/03/2019 (Wednesday)
Time : 15:00 hrs
Venue : "Hotel Nandan", Guwahati.

The List of Participants in the 154th OCC Meeting is attached at **Annexure – I**

Shri P.K. Mishra, Member Secretary, NERPC welcomed all the participants to the 154th OCC meeting. He mentioned that during the customers' meet of NTPC on 8th & 9th March, 2019, NTPC had informed about the various training program envisaged for the benefit of power sector. He stated that he had requested NTPC to give the training schedules during OCC meeting of NERPC so that members can decide the courses of training. He informed the house that the teams from NTPC are present in the meeting and the presentation will be given by them on training schedules. He also welcomed Shri Jagan Mohan from CDAC & the team from PRDC respectively and hoped that clarifications on CDAC issue and PDMS will be addressed during the meeting. He noted the absence of representatives from Ar. Pradesh & Nagaland for the last two meetings and expressed dissatisfaction as many issues pertaining to these States cannot be updated. He mentioned the forum that NERPC will take up the matter with their managements so that full representations should be there from all Utilities. He requested all to actively participate in the meeting for fruitful deliberations.

Thereafter, Member Secretary requested Shri B. Lyngkhoi, Director (O&P) to take up the agenda for discussion. Director, NERPC informed the forum the various presentations as below:

- a. Training Schedules: By NTPC
- b. TARA Devices & Integration: By CDAC
- c. PDMS Progress: By PRDC

Deliberation of the sub-Committee:

The gist of Customers' Training as presented by NTPC is as below:

- NTPC aspiring to give training to 40% external officers from various utilities
- L&D governance of NTPC
- Various benefits of L&D programs

- Calendar training to be given by NTPC to NERPC - by 31/03/2019 and names to be given by all utilities

MS, NERPC informed that a committee would be formed to discuss the training programs required for engineers of different utilities in NER.

The Sub-Committee noted as above.

Action: All state utilities/NERPC.

A. CONFIRMATION OF MINUTES

CONFIRMATION OF MINUTES OF 153rd MEETING OF OPERATION SUB-COMMITTEE OF NERPC.

The minutes of 153rd meeting of Operation Sub-committee held on 14th February, 2019 at Guwahati were circulated vide letter No. NERPC/SE (O)/OCC/2016/4556-4591 dated 28th February, 2019.

The Sub-committee confirmed the minutes of 153rd OCCM of NERPC as no comments/observations were received from the constituents.

ITEMS FOR DISCUSSION

B.1. ACTION TAKEN:

1. IMPLEMENTATION OF PROJECTS FUNDED FROM PSDF:

The status as informed in 152nd OCC:

| State | R&U scheme | ADMS | Capacitor Installation | SAMAST ** | Line Differential Protection |
|-------------|---|-------------------------------------|---|-------------------------------|--|
| Ar. Pradesh | Pkg-I: OBD completed. By Feb'19 LOA. Pkg-II: Tendering in process. | To submit comments to NIT by 18/02. | - | TESG queries submitted. | - |
| Nagaland | Pack-B: Dec'18 Pack-C: Dec'18 | To submit comments to NIT by 18/02. | To submit re-proposal to NERPC for Study. | TESG queries to be submitted. | Lines identified. Under DPR preparation stage. |

| | | | | | |
|-----------|--|---|--|--------------------------------------|--|
| Mizoram | LOAs issued. Completion by Mar'19. | To submit comments to NIT by 18/02. | To re-submit proposal to NERPC for Study. | TESG queries submitted. | Lines not yet identified. To be taken up in Sub-group. |
| Manipur | LOAs issued. Completion by Nov'18. | To submit comments to NIT by 18/02. | Submitted to NERPC for Study before sending to NPC/NLDC. | TESG queries to be submitted. | Lines not yet identified. To be taken up in Sub-group. |
| Tripura | 90% completed. Remaining by Feb'19 | To submit comments to NIT by 18/02. | To submit proposal to NERPC for Study. | TESG queries submitted. | Lines not yet identified. To be taken up in Sub-group. |
| Assam | Substation auxiliary and diagnostics tools - Tendering in process. LOA by Dec'18. | To submit comments to NIT by 18/02. | - | TESG queries submitted. | Lines identified. Under DPR preparation stage. |
| Meghalaya | MePTCL LOA issued, 95% completed. Remaining LOAs by Feb'19. Commissioning works 60% completed, Total balance works by Jun'19. MePGCL - Erection complete by Mar'19 | Revised DPR submitted. Query referred to DISCOM | - | TESG queries submitted. | DPR already submitted and awaited approval. |

Deliberation of the sub-Committee:

Director, NERPC highlighted the draft NIT of ADMS. The forum discussed the pointwise issue of ADMS and their comments were incorporated in the NIT

documents. The forum also requested SLDCs to forward the amended NIT to their DISCOMs counterpart if they have any comments/observations and if no comments are received by 31.03.2019, the NIT is treated as final.

Further, he mentioned that the SAMAST project of NER will be discussed on 25.03.2019 at Delhi and requested all the NER States to present during the above meeting so that if any clarification required; the same can be resolved.

The Sub-Committee noted as above.

Action: All state utilities/NERPC.

2. Outage of Important Grid Elements:

| Name of the Element | Name of Utility | Status as informed in 154th OCC |
|--|------------------------|--|
| 63MVAR Reactor at Byrnihat to replace with 80MVAR Reactor | MePTCL | NERPC will write to CEA for inclusion in NERSCT's MoM. |
| Outage of 420kV 80MVAR L/R for 400kV Bongaigaon-NSLG-I at Bongaigaon - (out since 04.07.18) | NERTS | By March, 2019 |
| 132kV Dimapur - Imphal (out since 25.07.18) | NERTS | During 154 th OCCM, Sr.GM (AM) NERTS informed that ROW issue for locations under Kohima District are yet to be resolved. In this regard, Power Commissioner of Nagaland has already made communication to Commissioner Home Nagaland on 11.03.19 for early resolution of the issue. Under such circumstances, Sr.GM (AM) informed the forum that the completion of job may scroll to June 2019 only if ROW issues are resolved within March 2019. The main reason of delay is ROW issue and thus extension of availability is due as per initial MOM. |
| 220kV Sonabil-Samaguri-I | AEGCL | LOA by March, 2019 |
| 420kV 63 MVAR Line Reactor at 400 kV Bongaigaon S/S for 400kV Bongaigaon- Azara(out since Nov'18) | NERTS | By March, 2019 Subject to SD approval |

The Sub-Committee noted as above.

Action: All concerned utilities & NERPC.

DIFFERENCE IN ACTUALS VS LGBR:**Energy Requirement:**

| Name of State | Sep 18 (actual) | Sep 18 (LGBR) | Oct 18 (actual) | Oct 18 (LGBR) | Nov 18 (actual) | Nov 18 (LGBR) | Dec 18 (actual) | Dec18 (LGBR) |
|---------------|-----------------|---------------|-----------------|---------------|-----------------|---------------|-----------------|--------------|
| Ar. Pradesh | 74.16 | 71.19 | 70.06 | 77.25 | 67.34 | 77.97 | 75.90 | 72.19 |
| Assam | 950.19 | 934.64 | 815.67 | 885.83 | 707.55 | 707.17 | 691.41 | 719.43 |
| Manipur | 69.88 | 69.64 | 75.80 | 75.56 | 81.80 | 78.59 | 89.09 | 87.43 |
| Meghalaya | 150.14 | 164.00 | 144.61 | 166.00 | 163.83 | 169.00 | 192.05 | 175.00 |
| Mizoram | 58.04 | 39.37 | 70.64 | 44.19 | 67.71 | 47.06 | 53.75 | 56.60 |
| Nagaland | 80.49 | 76.88 | 74.27 | 69.66 | 61.04 | 64.67 | 79.63 | 80.10 |
| Tripura | 192.00 | 125.18 | 187.38 | 132.09 | 164.71 | 98.49 | 165.65 | 96.16 |

Energy Availability:

| Name of State | Sep 18 (actual) | Sep 18 (LGBR) | Oct 18 (actual) | Oct 18 (LGBR) | Nov 18 (actual) | Nov 18 (LGBR) | Dec 18 (actual) | Dec18 (LGBR) |
|---------------|-----------------|---------------|-----------------|---------------|-----------------|---------------|-----------------|--------------|
| Ar. Pradesh | 81.12 | 82.62 | 67.90 | 77.45 | 64.46 | 63.39 | 61.98 | 57.96 |
| Assam | 987.64 | 859.96 | 772.79 | 898.78 | 747.84 | 795.50 | 748.10 | 765.58 |
| Manipur | 177.79 | 110.48 | 105.39 | 117.42 | 85.54 | 106.01 | 101.86 | 87.00 |
| Meghalaya | 276.17 | 308.96 | 200.13 | 274.43 | 175.54 | 206.71 | 206.14 | 194.14 |
| Mizoram | 111.76 | 89.77 | 106.29 | 83.22 | 89.63 | 69.34 | 67.34 | 58.83 |
| Nagaland | 81.24 | 87.96 | 68.17 | 88.06 | 53.51 | 72.04 | 63.19 | 65.59 |
| Tripura | 309.44 | 268.15 | 342.04 | 300.01 | 332.36 | 272.69 | 336.56 | 280.83 |

Demand:

| Name of State | Sep 18 (actual) | Sep 18 (LGBR) | Oct 18 (actual) | Oct 18 (LGBR) | Nov 18 (actual) | Nov 18 (LGBR) | Dec 18 (actual) | Dec18 (LGBR) |
|---------------|-----------------|---------------|-----------------|---------------|-----------------|---------------|-----------------|--------------|
| Ar. Pradesh | 131.92 | 143 | 129.08 | 146.00 | 127.77 | 145.00 | 132.80 | 140.00 |
| Assam | 1865.26 | 1787.60 | 1785.42 | 1840.56 | 1546.54 | 1558.56 | 1440.10 | 1506.61 |
| Manipur | 184.39 | 168.04 | 187.28 | 175.61 | 189.23 | 182.53 | 213.75 | 196.00 |
| Meghalaya | 317.42 | 328.18 | 336.23 | 320.58 | 352.42 | 342.37 | 365.46 | 405.90 |
| Mizoram | 95.47 | 95.23 | 99.18 | 96.76 | 102.12 | 104.38 | 111.57 | 114.40 |
| Nagaland | 142.07 | 148.77 | 133.77 | 138.05 | 139.00 | 133.50 | 135.04 | 156.55 |
| Tripura | 296.01 | 359.46 | 269.32 | 312.39 | 258.54 | 278.62 | 239.53 | 225.23 |

Deliberation of the sub-Committee:

Member Secretary, NERPC stated that the disparities in actual vs LGBR should be taken into account while submitting the LGBR data for 2019-20.

The Sub-committee noted as above.

Action: All SLDCs.

B.2. OPERATIONAL PERFORMANCE AND GRID DISCIPLINE DURING FEBRUARY, 2019

As per the data made available by NERLDC, the grid performance parameters for February, 2019 are given below:

NER PERFORMANCE DURING FEBRUARY, 2019

| States | Energy Met (MU) | | w.r.t. Jan,19 % inc (+) /dec (-) | Energy Reqr. (MU) | | w.r.t. Jan,19 % inc (+) /dec (-) | % inc (+) /dec (-) of energy reqr vs met. In Feb,19 |
|---------------|-----------------|----------------|--|-------------------|----------------|--|---|
| | Feb-19 | Jan-19 | | Feb-19 | Jan-19 | | |
| Ar. Pradesh | 76.93 | 68.24 | 12.73 | 77.28 | 68.59 | 12.67 | -0.45 |
| Assam | 621.73 | 711.61 | -12.63 | 635.00 | 720.73 | -11.89 | -2.09 |
| Manipur | 94.74 | 85.75 | 10.48 | 95.46 | 86.24 | 10.69 | -0.75 |
| Meghalaya | 188.34 | 198.64 | -5.19 | 188.35 | 198.64 | -5.18 | -0.01 |
| Mizoram | 70.46 | 54.55 | 29.17 | 70.98 | 55.05 | 28.94 | -0.73 |
| Nagaland | 77.40 | 64.14 | 20.67 | 85.74 | 72.48 | 18.29 | -9.73 |
| Tripura | 147.46 | 115.91 | 27.22 | 148.35 | 116.00 | 27.89 | -0.60 |
| Region | 1277.05 | 1298.85 | -1.68 | 1301.15 | 1317.74 | -1.26 | -1.85 |

| States | Demand Met (MW) | | w.r.t. Jan,19 % inc (+) /dec (-) | Demand in (MW) | | w.r.t. Jan,19 % inc (+) /dec (-) | % inc (+) /dec (-) of energy reqr vs met. In Feb,19 |
|---------------|-----------------|-------------|--|----------------|-------------|--|---|
| | Feb-19 | Jan-19 | | Feb-19 | Jan-19 | | |
| Ar. Pradesh | 148 | 124 | 19.35 | 138 | 138 | 0.00 | -6.76 |
| Assam | 1440 | 1468 | -1.91 | 1417 | 1491 | -4.96 | -1.60 |
| Manipur | 194 | 216 | -10.19 | 192 | 219 | -12.33 | -1.03 |
| Meghalaya | 356 | 372 | -4.30 | 355 | 372 | -4.57 | -0.28 |
| Mizoram | 109 | 119 | -8.40 | 102 | 121 | -15.70 | -6.42 |
| Nagaland | 132 | 138 | -4.35 | 130 | 140 | -7.14 | -1.52 |
| Tripura | 231 | 223 | 3.59 | 231 | 224 | 3.13 | 0.00 |
| Region | 2514 | 2552 | -1.49 | 2480 | 2575 | -3.69 | -1.35 |

REGIONAL GENERATION & INTER-REGIONAL EXCHANGE IN MU

| Month----> | Feb-19 | Jan-19 |
|---|----------------|---------------|
| Total Generation in NER (Gross) | 1101.311 | 1337.745 |
| Total Central Sector Generation (Gross) | 841.084 | 1048.299 |
| Total State Sector Generation (Gross) | 260.227 | 289.446 |
| Inter-Regional Energy Exchange | | |
| (a) NER-ER | 184.75 | 372.13 |
| (b) ER-NER | 1.07 | 1.15 |
| (c)NER-NR | 4163.00 | 0.00 |
| (d)NR-NER | 45.83 | 433.45 |
| © Net Import | -4300.85 | 62.47 |

AVERAGE FREQUENCY (Hz)

| Month----> | Feb-19 | Jan-19 |
|--------------------------|-----------|-----------|
| | % of Time | % of Time |
| Below 49.9 Hz | 7.23 | 10.69 |
| Between 49.9 to 50.05 Hz | 70.92 | 70.25 |
| Above 50.05 Hz | 21.85 | 19.06 |
| Average | 50.00 | 49.99 |
| Maximum | 50.26 | 50.28 |
| Minimum | 49.68 | 49.58 |

Deliberation of the sub-Committee:

NERLDC gave a presentation on the grid performance for the month of February'19 (**Annexure-B.2-a**). NERLDC also highlighted that Daily, Weekly and Monthly Voltage Deviation Report, Frequency Deviation Report and System Reliability Report for February'19 was already mailed to all the constituents for necessary actions. Further, it was informed that members may access these reports from NERLDC website under the tab CERC KPI Reports. NERLDC informed the forum about the number of lines kept open on high voltage. NERLDC again requested for early restoration of reactors which are under long outage and commissioning of new reactors at the earliest as mentioned in Sl. No. B.1.2 and C.1 and support from Generator to control voltage so that it does not require to open lines for maintaining voltage profile within IEGC band.

The Sub-Committee noted as above.

| |
|-----------------------------|
| ITEMS FOR DISCUSSION |
|-----------------------------|

| |
|---------------------|
| C. OLD ITEMS |
|---------------------|

1. Status of Generating Units, Transmission Lines in NER:

During 154th OCC meeting, the status as informed by different beneficiaries is as follows:

| SN | Items | Status as given in 153 rd OCC Meeting | | Status as given in 154 th OCC Meeting | |
|------------------------|--|--|---------------------------------|--|---------------------------------|
| | | Timeline for completion | Furnishing of detail parameters | Timeline for completion | Furnishing of detail parameters |
| a. New Elements | | | | | |
| 1 | 250 MW BgTPP Unit #III | - | - | By Mar'19 | To be submitted to NERLDC. |
| 2 | 400/220kV, 315 MVA ICT-1 of NTPC at Bongaigaon | By Mar'19 | To be submitted to NERLDC. | By Mar'19 | To be submitted to NERLDC. |
| 3 | Kameng HEP of NEEPCO two units (2 x 150 MW) Next two units (2x150 MW) | To be reviewed | Already submitted. | By July'19 | Already submitted. |

| | | | | | |
|--|--|---|--|---|--|
| 4 | 132kV Monarchak – Surjamaninagar D/C of TSECL | by Jun'19 | To be submitted to NERLDC. | by Jun'19 | To be submitted to NERLDC. |
| 5 | 400/220 kV 315 MVA ICT-II at Bongaigaon | LV side (GIS) is expected to be completed by Mar'19. | LV side separate application to be submitted | LV side (GIS) is expected to be completed by Apr'19. | LV side separate application to be submitted |
| 6 | 220/132 kV, 160MVA ICT-II at Balipara | Not allowed for transit by WB Govt. to factory. Uncertain date. | To be submitted to NERLDC. | Apr'19 | To be submitted to NERLDC. |
| 7 | 220/132 kV, 1x160 MVA ICT with GIS Bay at Kopili | Expected to be completed by Mar'19 | To be submitted to NERLDC. | Apr'19 | To be submitted to NERLDC. |
| 8 | 33kV bay at 220kV Mariani(AS) S/Sn | PG to pay by Jan'19 | Not applicable. | Decided to resolve bilaterally & dropped | Not applicable. |
| 9 | 33kV bay for 132kV Badarpur(PG) S/Sn | To be expedited by APDCL. | Not applicable. | Decided to resolve bilaterally & dropped | Not applicable. |
| 10 | Dedicated 33kV feeder at Khliehriat Substation from Lumshnong. | To be taken up with MePDCL. SLDC to kindly mediate. | Not applicable. | To be taken up with MePDCL. SLDC to kindly mediate. | Not applicable. |
| 11 | Replacement of 2x315 MVA ICTs with 2x500 MVA ICTs at Misa (PG) | ICT-I expected by May'19 and ICT-II by Jun'19 | To be submitted to NERLDC. | <ul style="list-style-type: none"> • ICT-I Expected by March'19 without Tertiary connectivity of 4X25MVAR Tertiary Reactors and • ICT-II Expected by Jun'19 | To be submitted to NERLDC. |
| 12 | 220kV Balipara-Sonabil-2 | | | | AEGCL will intimate the status in next OCC Meeting |
| b. Elements under breakdown/upgradation | | | | | |
| 13 | Up-gradation of 132 kV Lumshnong-Panchgram line | DPR sent to NLDC/NPC | Not applicable. | DPR sent to NLDC/NPC | Not applicable. |

| | | | | | |
|----|--|---|---------------------------|--|---------------------------|
| 14 | Switchable line Reactors at 400 kV Balipara & Bongaigoan Ckt # 1 & 2 | Balipara : CSD tuned for Ckt-1 S/D applied for Ckt-II on 04.02.19 Bongaigaon: Completed | Not applicable | Completed in all aspects & dropped. | Not applicable |
| 15 | PLCC Panels at Loktak end of Ningthoukhong 132 kV feeder and Loktak - Rengpang 132 kV feeder | Panels not supplied at Loktak end. NERPC to write to MD, MSPCL to expedite. | Not applicable. | May'19 | Not applicable. |
| 16 | Replacement of CTs and installation of Bus Bar Protection at 220 kV Misa | Expected Completion : Mar'19 | Not applicable | Expected Completion : Apr'19 | Not applicable |
| 17 | Upgradation of 132 kV Bus Bar at Umiam Stg-III to ACSR Zebra | DPR will be submitted soon. | Not applicable | DPR will be submitted soon. | Not applicable |
| 18 | 220/132 kV 30 MVA ICT at Mokokchung | Mar'19(LOA date) to be reviewed later on. | To be submitted to NERLDC | Mar'19(LOA date) to be reviewed later on. | To be submitted to NERLDC |

The forum expressed concerned about the time frame given by the utilities as the dead line was not adhered to. The forum decided that utilities should give the dead line from the date of LOA and the countdown will start henceforth from the Date of LOA.

The Sub-Committee noted as above.

Action: All state utilities/central utilities/NERPC.

C.2. Update on Real Time Energy Assessment for Effective Grid Management:

In 153rd OCC meeting, it was decided that a Special Meeting would be convened to resolve the issues pertaining to REAL/TARA, SCADA & Communication.

NERTS has been advised to complete installation/replacement of SEMs as per list below –

| SL NO | FEEDER NAME | STATUS | METER TO BE REPLACED/ INSTALLED BY PGCIL | Status |
|-------|-------------|--------|--|--------|
|-------|-------------|--------|--|--------|

| | | | | |
|---|--|---------|---|---|
| 1 | SRIKONA END OF 132kV SILCHAR FDR -1 | REPLACE | 1 | To be done on 15 th March'19 |
| 2 | SRIKONA END OF 132kV SILCHAR FDR -2 | REPLACE | 1 | |
| 3 | DEOMALI END OF 220 KV KATHALGURI FEEDER | REPLACE | 1 | Completed |
| 4 | MOKOK(S) END OF MOKOK- MOKOK-1 | REPLACE | 1 | To be completed by 25 Th March'19 |
| 5 | MOKOK(S) END OF MOKOK- MOKOK-2 | REPLACE | 1 | |
| 6 | KHUPI END OF 132 KV BALIPARA | INSTALL | 1 | Khupi end requested to install the meter after 15 th March because of non- availability of concerned person |
| 7 | KHUPI END OF 132 KV KAMENG | INSTALL | 1 | |
| 8 | LEKHI END OF 132 KV PARE | INSTALL | 1 | Completed |
| 9 | ZUANGTUI END OF MELRIAT | INSTALL | 1 | Letter given to state for providing necessary permissio n for fitting of new meters. Reply awaiting |

Deliberation of the sub-Committee:

CDAC informed all the installation of TARA devices will be completed by 31.03.2019. He mentioned that SAT certificates have to be issued by respective SLDCs and requested them to issue the same. Further, he stated that data from various locations can be retrieved within 10 days (storage time) else the previous data will get erased automatically. Regarding linking the schedule from WBES, CDAC stated that it was not in the scope of the project and for this to be integrated and additional amount of Rs. 8 lakhs are to be paid by the beneficiaries; members agreed in principle, however, the same has to be endorsed in the next TCC/NERPC Meetings.

Review was taken about performance of already installed TARA devices in different States. It was seen that except Manipur, it was less than satisfactory in other States. CDAC mentioned lack of proper GPRS signal as reason. However, as in many places of Tripura, data was not available, CDAC and Tripura were advised to check and ensure correctness. States were advised to take care of the Project as it would help them in tracking ZCV.

Regarding installation of software in Tripura server in addition to NERLDC, CDAC said it would be possible and they would do in coordination with Tripura.

The forum requested CDAC to develop a SMS alert App. CDAC intimated that tentative cost would be Rs.15,000/- for each of the constituents.

Members agreed in principle, however, the same has to be endorsed in the next TCC/NERPC Meetings.

The Sub-Committee noted as above.

Action: All state utilities/central utilities/NERPC.

C.3. Ensuring proper functioning of Under Frequency Relays(UFR) & df/dt Relays:

In 7th NPC meeting held on 08.09.17 it was agreed that mock test is good enough to test the healthiness of the UFR & df/dt relays. The frequency of site inspection was proposed to be upto six months. RPC may carry out periodic inspection, in line with provisions of IEGC and furnish inspection reports to NPC.

Discussions as per previous meetings:

- Inspection for Mawphlang completed.
- Inspection for Baghjap, Sankardevnagar and Sipajhar under Assam would be tentatively done by 1st week of Mar'19.

Deliberation of the sub-Committee:

Director, NERPC informed that due to pre-occupation, NERPC could not finalize the date for inspection and expressed deeply regretted. The inspection will be carried out in the month of April, 2019.

The Sub-Committee noted as above.

Action: NERPC.

C.4. Extended C Band VSAT for power system communications in NER:

As per discussion in previous meetings:

- □ Leased Line Connectivity has been explored by NERTS for Roing, Tezu & Namsai with recurring expenditure amounting to INR 28 lakhs.
- □ VSAT Pilot project to be executed at Byrnihat station. The data would be transmitted from Byrnihat to KPTCL (via satellite) to SRLDC to NLDC to NERLDC. This would be kept in monitoring mode in the interim. Pilot project cost breakup is to be put up for approval in the next TCC/RPC meeting. NERLDC has requested for finalisation of modality for VSAT pilot project. Quotation enclosed as Annexure-21
- □ NERPC to take up with proper authorities for funding of VSAT in NER from suitable sources.
- □ Financial impact for NER states i.r.o. VSAT for Roing, Tezu, Namsai by POWERGRID is to be explored (tentative cost is ₹ 54,653,880.00 for 5 years). matter has been referred to Corporate LD&C.
- □ Technical visit on 10.12.2018 concluded that VSAT for NER is technically feasible.

Deliberation of the sub-Committee:

CGM, NERLDC requested to finalize modalities regarding the pilot project. After detailed deliberation, the OCC decided that since the project is a pilot one, the order may be given to M/s KPTCL.

Director, NERPC requested NERLDC to intimate the exact cost of above pilot project for one year so that the same can be endorsed in the next TCC/NERPC Meetings.

The Sub-Committee noted as above.

Action: NERPC/NERLDC.

C.5. DIMAPUR PG Voice communication and telemetry out since Feb'18.

In 152nd OCCM NERTS informed that Dimapur communication would be restored by March, 2019.

Deliberation of the sub-Committee:

NERTS informed that as per 148th OCC meeting the voice has already been restored on March'18. LOA has been placed to M/s GE which include both supply and installation. To be completed by June'19. However all the analog signals has been made through and also almost 80% digital signals are also reporting.

NERLDC stated that the above status is not correct and hence requested NERPC to conduct the NETeST Meeting on monthly basis as decided so that the issues can be sorted out for the benefit of the region.

The Sub-Committee noted as above.

Action: NERPC.

C.6 Update on PDMS:

As per deliberation in the previous meeting(s) the following status/decisions:

- Operational load flow has been completed and circulated to all constituents for comments. *SLDCs may please update the status.*
- Database building and network modelling for Assam has been completed.
- Server installation at NERPC to commence in March'19.

Deliberation of the sub-Committee:

M/s PRDC informed the forum that job for Pilot State i.e. Assam has been completed and they wanted to go for SAT w.e.f. 25.03.19 to 28.03.19.

NERLDC requested to circulate the verifiable documents to NERPC, NERLDC, NERTS and AEGCL in advance by 15.03.2019. PRDC agreed.

The next state for data collection would be Meghalaya - In Apr'19

It was decided a technical committee would be formed with protection experts from various utilities i.r.o. PDMS project.

The Sub-Committee noted as above.

Action: PRDC.

C.7. Submission of the Annual Load Generation Balance Report (LGBR) for Peak as well as Off-peak scenarios and the Annual outage plan for 2019-20 by 31.12.18 as per IEGC.

As per IEGC, each SLDC shall submit LGBR for its control area, for peak as well as off-peak scenario, by 31st December for the next financial year, to respective RPC Secretariat. The annual plans for managing deficits/surpluses in respective control areas shall clearly be indicated in the LGBR submitted by SLDCs.

As per IEGC, all SEBs/STUs, Transmission Licensees, CTU, ISGS, IPPs, MPPs and other generating stations shall provide to the respective RPC Secretariat their proposed outage plan in writing for the next financial year by 31st October of each year. These shall contain identification of each generating unit/transmission line/ICT

etc., the preferred date for each outage and its duration and where there is flexibility, the earliest start date and latest finishing date.

In 153rd OCC, Director, NERPC stated that the LGBR for 19-20 would be completed by 28.02.19.

Deliberation of the sub-Committee:

NERPC displayed the LGBR for FY 2019-2020. It was requested to all the utilities to go through the Report and give comments if any before 31.03.2019, else the LGBR will be treated as final.

The Sub-Committee noted as above.

Action: All Utilities.

C.8 Non-availability/ Non-functioning of synchronization facility at numerous stations

As per deliberations in the previous the following is the status for synchronization facility at stations of different utilities:

NERTS – All stations synchronization facility available. The same is available at RTAMC. Sync check to be tested for 132kV AGTCCPP-Kumarghat on 16.02.19-
NERTS status Checked and found OK at Kumarghat end.

- AEGCL – Sync check not available for 132kV stations. Procurement of synchronizing trolley and associated equipments (sockets etc.) to be completed by July'19. ***AEGCL may please update status.***
- DoP Ar. Pradesh – Sync check not available at Lekhi and Chimpu. Would be in place by Sep'19. ***DoP Ar. Pradesh may please update the status.***

Deliberation of the sub-Committee:

AGTCCPP – Kumarghat will be tested during the Black Start scheduled to be held in April, 2019.

AEGCL was requested to give the date once LOA is placed as decided earlier.

Regarding check sync of Ar. Pradesh, the status could not be updated due to absence of representative.

The Sub-Committee noted as above.

Action: All concerned Utilities.

C.9 Compliance of CERC Order:

Against compliance of CERC Order dated 14.06.2016(Non-compliance of Commission's direction dated 26.9.2012 in Petition No. 168/MP/2011) in Petition No.09 & 10/SM/2014 Commission directed RPCs Secretariat to examine the cases of delayed clearance of faults on the transmission system during last two years in respective Region and submit an analysis report within six month from the date of issue of order.

The 153rd OCC forum requested NERLDC to compile the cases of delayed clearance of faults on the transmission system for 2016-17 and 2017-18. NERLDC agreed and promised that the report would be compiled latest within two months.

Deliberation of the sub-Committee:

CGM, NERLDC informed that the compilation is in progress and the same will be submitted to NERPC by April, 2019.

NERPC once again thanked NERLDC for their cooperation.

The Sub-Committee noted as above.

Action: NERLDC.

C.10 Phase shift errors in PMU:

In 153rd OCCM Sr.GM, NERTS informed that the 220kV of NER has phase matching with 220kV ER(Birpara). So, at present it is not recommended to change at primary as downstream will be affected. After detailed deliberations, the forum decided that wirings in the secondary may be changed. In this regard, a matrix is to be made for changing the connections. Since PMU is not installed in all ISTS elements, concerned utilities are requested to trigger DR output manually for all ISTS elements and submitted to NERPC/NERLDC for preparation of the matrix. It was decided that a team from NERPC (Sh Srijit Mukherjee), NERTS (Sh. Supriya Paul/Devaprasad Paul), NERLDC (Sh. Zerin Jacob) & AEGCL (Sh. Abhishek Kalita) will identify the exact problem at Silchar, Misa & Sarusajai by Feb'19.

Deliberation of the sub-Committee:

Members agreed that the work will be completed by April, 2019.

The Sub-Committee noted as above.

C.11 Compensation for Heat Rate degradation and Auxiliary Energy Consumption in case of gas based power plants:

In 153rd OCCM it was decided that a Special Meeting would be convened prior to the 153rd OCC to discuss the Heat Rate Degradation and Compensation Calculation for Thermal Power Plants.

Deliberation of the sub-Committee:

It was agreed that the matter would be discussed in a separate meeting as in C 13.

The Sub-Committee noted as above.

C.12 Design & implementation of SPS for Outage of 400 kV Bus

400 kV Bus — I & II at Silchar (PG) and Outage of any one circuit of 400 kV Bongaigaon — BgTPP D/C

In 153rd OCCM, CGM, NERLDC clarified that upon System Study by NERLDC the above SPS has been proposed. After detailed deliberation, it was decided that the matter would be discussed in System Study Meeting separately. NERPC informed that System Study Meeting would be scheduled in the 1st week of Mar'19.

Deliberation of the sub-Committee:

The matter would be discussed in System Study Meeting in April'19 as in C 13.

The Sub-Committee noted as above.

C.13 Schedule for special meeting on review of existing SPSs & devising new SPSs as per present requirement of NER grid

In 153rd OCCM it was decided that the matter would be discussed in System Study Meeting separately.

Deliberation of the sub-Committee:

The forum decided to have a Special meeting on 25.04.2019 for above Items C.11 to C.13. The exact venue will be intimated in due course.

The Sub-Committee noted as above.

Action: NERPC.

C.14 Operation of RHEP units in Synchronous condenser mode

In 153rd OCCM, Sr. Manager, NEEPCO informed that prima-facie it appears that Synchronous Condenser mode operation is not possible. However NEEPCO has written to BHEL(Bhopal) for solution. This item would be reviewed in the next meeting.

Details enclosed as Annexure-C.14

NEEPCO update: M/s BHEL has informed that as per design of turbine and generator the generator can work in synchronous condenser mode. However the embedded pipe, air compressed system, DVR, protection logic etc. as per 2nd stage foundation drawing is not in place. This is in scope of NEEPCO.

Deliberation of the sub-Committee:

NEEPCO informed that the matter has been taken up with BHEL and the reply is awaited by mid April'19. The same will be intimated to the forum accordingly.

The Sub-Committee noted as above.

Action: NEEPCO.

C.15 Providing High speed, reliable internet connection by all ISGS & SLDCs

In 153rd OCCM, CGM, NERLDC stated that in light of the commissioning of WBES it has become very essential for all the ISGSs and SLDCs to have high speed internet connection. The forum noted that the matter has already been taken up in the 19th NERPC meeting for urgent action. The members requested NERLDC to explore the following:

- a. A Lite version of WBES website with less features. This will enable punching requisition/DC even over 2G/EDGE network,
- b. USSD based application for transmission of schedule related information in real time. NERLDC agreed to the same.

Deliberation of the sub-Committee:

Meghalaya SLDC informed that 6Mbps lease line from BSNL is being taken in lieu of 2Mbps link in service.

NERLDC informed that Lite version and USSD application is not feasible.

Considering the fact that States had no issues with Internet, it was agreed to drop the item.

The Sub-Committee noted as above.

C.16 Accurate Load forecasting by SLDCs as per IEGC c1.5.3 for better system operation

In 153rd OCCM NERLDC presented the RMSE for the month of Dec'18:

| % Error with Actual Data (Forecasted by States) | | | | | | | |
|---|------------|----------|----------|-----------|-----------|-----------|----------|
| | Ar Pradesh | Assam | Manipur | Meghalaya | Mizoram | Nagaland | Tripura |
| Median | 16 | 6 | 7 | 10 | 32 | 12 | 8 |

Mizoram & Arunachal Pradesh SLDCs are requested to check the methodology for improving the load forecast.

Deliberation of the sub-Committee:

Mizoram informed that the issue will be intimated in the next OCC. Ar. Pradesh could not be updated due to absence of representative.

The Sub-Committee noted as above.

C.17 Construction of Bay for 132kV Agia-Nongalbibra Line at 220kV Agia Sub Station, Agia, Assam

Stringing of 2nd Circuit 132kV Nongalbibra -Agia Line (SPA Scheme) Rs. 1.11 Cr Deposited by MePTCL by SBI Chq No. 511140 Dt. 15.03.2016 for the above work. Stringing of the Line Completed in 2018.

MePTCL requested AEGCL to kindly intimate the latest status at the earliest.

Deliberation of the sub-Committee:

Meghalaya informed that stringing of line in their portion is almost completed.

AEGCL informed that C&R panels is yet to be installed. For this temporarily Non-SAS compatible panel would be diverted from other site. By Apr'19

The Sub-Committee noted as above.

C.18 Inclusion of OPGW in scope of Reconductoring of lines with OPGW:

In 153rd OCCM, EE, System Protection, MePTCL, informed the Chair on the observations of TESSG on the DPR's for re conductoring of lines with HTLS submitted by MePTCL wherein the observations desires that the OPGW component be excluded from the scope of works in DPR's. He requested the Chair to take up with the matter with NLDC for consideration of the OPGW item in DPR.

Deliberation of the sub-Committee:

Director, NERPC informed that the matter has been taken up with to MoP and same has been shared with MePTCL. Item to be dropped.

The Sub-Committee noted as above.

C. 19 Tentative schedule for Black Start & Restoration Procedure Mock exercise in NER during the year 2019

The 153rd OCC forum requested NERLDC to prepare and circulate the tentative schedule for Black Start & Restoration Procedure Mock exercise. The tentative schedule is as follows:

| | | |
|------------------------------------|---|--|
| AGTCCPP | March 2019---April 2019 | To be shifted to April'2019 as per NEEPCO |
| Loktak | April 2019 | |
| Khandong & Kopili st II | May 2019 | Date feasible |
| Kopili | June 2019 | Date feasible |
| AGBPP | July 2019**no black start facility | No black start facility |
| Ranganadi | August 2019**132kV only 400kV not possible | Dead bus charging possible in 132kV only. Not possible in 400kV. |
| Pare | September 2019 | after COD black start not done OEM contract dead bus charging clause, OEM to demonstrate |
| Doyang | October 2019 | Date feasible |

Respective ISGSs are requested to finalize the dates for the mock exercise as per the tentative schedule.

The draft Procedure for Mock Black Start for AGTCCPP was shared via email dated 06.03.2019 by NERLDC.

Tentative schedule for BSRP workshop in NER- 27 March 2019

Tentative procedure for mock black start exercise for AGTCCPP and synchronising facility testing at Kumarghat Substation (PG). Email copy and Tentative Procedure enclosed in **Annexure -19**.

Deliberation of the sub-Committee:

The mock black start schedule was agreed as below:

AGTCCPP 09-04-19

LOKTAK 12-04-19

Khandong 06-06-19

KOPILI 07-05-19

RHEP 1st week of June'19

DOYANG 2nd week of June'19

The Sub-Committee noted as above.

C. 20 DVAR and PSS at AGTCCPP:

Expected date of commissioning of DVAR and PSS at AGTCCPP. Letter No NERLDC/SO-II/2798 dated 22.02.19 regarding low frequency oscillations observed at Agartala PMU is enclosed as Annexure C.20.a. Oscillation observed in AGTCCPP Bus during low loading and synchronization of Unit 1 (Details are enclosed as Annexure-C.20.b.

DVAR,PSS - at site. rheap full s/d kopili s/d thermal power station s/d not possible

Deliberation of the sub-Committee:

Sr. Manager, NEEPCO informed that the DVAR & PSS have already arrived at site and the same is to be commissioned now. AGTCCPP informed the FORUM that they changed the control system for Unit I. After the return of Unit 4, they will replace old AVR with DVAR along with PSS tentatively by April'19.

The Sub-Committee noted as above.

Action: NEEPCO

C. 21 Metering Status Review:

Procurement of additional 70 Laptops:

POWERGRID intimated that LOA has already been placed to M/s HUE Services however the party has raised query regarding the terms and condition of LOA (which is the standard Terms and condition of POWERGRID). The matter has been taken up with C&M department for early solution of the issue. To be completed by 31st March'19.

Distribution of DCD:

POWERGRID intimated that DCD had been handed over to Chimpu and Pare station. Matter intimated to all SEBs and distribution under progress. To be completed by March'19.

Also matter has already been intimated to RC Nagar from Kumarghat Ss, Kohima and Doyang from Dimapur Ss, Manipur SEB from Imphal Ss but no response has been received yet for collecting the DCD. POWERGRID requested all the utilities to collect the same at the earliest.

Installation/Replacement of SEMs.

POWERGRID intimated that replacement was under progress. To be completed by 15th April'19. NERLDC requested to update status regularly.

Non-receipt of SEM Time Drift Report:

All utilities were requested to provide time drift status regularly.

Error observed in Meter readings:

1. □ Karong end of 132 kV Kohima line, meter no. NP-8373-A, sign reversal observed - Rectified
2. □ 132KV Kopili - Khandong feeder-II (BOTH MAIN & CHECK), meter no NP-9491-A & NP-9462-A, not functioning – Rectified.
3. □ PAILAPOOL END OF 132 kV JIRIBAM FDR, meter no NP-8498-A - Rectified
4. □ D'NGAR END OF DULLAVCHERRA FDR, Meter no NP -6892-B – As confirmed by RE, Dullavcherra at present there is no error.

NERLDC clarified that error was at Dharmanagar and checking would have to be done there.

Spare of SEMs / DCDs :

POWERGRID was requested to furnish latest list of spares.

5 min metering:

POWERGRID intimated that status would be updated in next meeting.

Additional Metering Point

Providing name and address of concerned Engineer in Charge for raising bills against procurement of laptops etc.

It was agreed that bills would be sent to the following for raising all bills and other financial issues regarding reimbursement of payment towards procurement of SEM, Laptop, Software etc. for ISTS:

1. □ CGM(Comml-T), APDCL, Bijuli Bhavan, Paltan Bazar, Guwahati- 781001
2. □ Director(Dist.), MePDCL, Meter Factory Area, Short Round Road, Integrated Office Complex, Shillong- 793001

3. □ Director(Tech.), TSECL, Bidyut Bhavan, North Banamalipur, Agartala-799001.
4. □ Chief Engineer (W. Zone), Dept. of Power, Govt. of Ar. Pradesh, Bidyut Bhavan, Itanagar- 791111.
5. □ Engineer-in-Chief, P & E Dept., Govt. of Mizoram, Khatla, Aizawl-796001.
6. □ Chief Engineer (Power), Dept. of Power, Govt. of Nagaland, Kohima-797001.
7. □ Managing Director, Manipur State Power Distribution Co. Ltd, Keishampat, Imphal- 795001

The Sub-Committee noted as above.

D. NEW ITEMS

D.1 Generation Planning (ongoing and planned outages)

NEEPCO/NHPC may kindly intimate the availability for hydro stations:

- a. Present per day MU and projected number of days of operation.

| Plants | Reservoirs level in meter as on 13-03-19 | MU content | Present DC (in MU) | No of days as per current generation |
|--------------------------|--|------------|--------------------|--------------------------------------|
| Khandong + Kopili stg II | 712.45 | 74.00 | 0.198 | |
| Kopili | 599.74 | 74.00 | 1.104 | |
| Doyang | 308.12 | 34.5 | 0.15275 | |
| Loktak | 768.31 | 34 | 1.097 | |

Thus, for maintaining the generation availability of NER Region it is requested to all hydro generations to judiciously plan the utilization of water and furnish the day ahead declared MU such that NER Region does not face lack of generation availability in the upcoming lean hydro season.

The outage of other generating stations may be approved considering the present water levels in reservoirs.

Deliberation in the Meeting:

The forum felt that in view of large number of shutdown underway for Hydel power stations requested all thermal stations to defer approved shutdown/forced outage till such time, when RHEP is returned to service.

The Committee discussed and approved the proposed shutdown by Generating Stations and the same has already been uploaded in the website of NERPC.

Action: All generating utilities/NERLDC.

D.2 Outage Planning Transmission elements

It was agreed in the 99th OCC meeting that shutdown will be availed only after approval is given by the OCC forum. It was also agreed that deferment/revision of outages elements other than already approved in OCC will be henceforth put/displayed in the website of NERPC (**under Operational Activities/OCC Approved shutdown**) as per CERC regulations/ CEA guidelines etc for ensuring smooth & secure grid operation.

Furnishing request of shut down of the element, which was approved by NERPC, by Indenting Agency (ISTS licensees/STUs/Generating Companies) to NERLDC:

Planned shutdown approved by NERPC shall be considered for implementation by NERLDC on D-3 basis. If an outage is to be availed on say 10th of the month, the shutdown availing agency would reconfirm to NERLDC on 7th of the month by 10:00 Hr. This practice is necessary to ensure optimal capacity utilization and the time required for associated system study/coordination by/amongst RLDC/NLDC.

In 134th OCCM, it was decided that all communication related shutdown be approved in OCC forum only.

In 142nd OCCM, Director (O&P), NERPC suggested that henceforth shutdown list may be prepared under following categories:

- (i) New Construction Related Shut Down
- (ii) Existing System Improvement Related Shut Down.
- (iii) Existing System Normal Maintenance Related Shut Down
- (iv) Communication Related Shutdown
- (v) R&U works Related Shut Down under PSDF

The forum further decided that the modalities of communication related shutdown should be finalized. Members requested NERPC to invite POWERGRID telecom in next

OCCM alongwith with officials (handling communication issues) from all utilities for this purpose.

Deliberation in the Meeting:

NERLDC highlighted that OCC forum approves the S/D after lots of discussion but it is observed that some of the shutdowns are not being availed. Details of Shutdown not availed and shutdowns applied on D-3 basis is as below:

| Total S/D approved | Total S/D availed | Total S/D not availed | Total S/D availed on D-3 basis | Total S/D not applied on D-3 basis |
|--------------------|-------------------|-----------------------|--------------------------------|------------------------------------|
| 136 | 86 | 50 | 61 | 25 |

It was decided that transmission utilities are requested to give copy of the mail for shutdown application on D-3 basis to all the SLDCs in addition to NERLDC.

NERLDC highlighted that the inordinate delay in revival of elements under S/D for ISTS licensees is coming very high which is affecting the secure operation of the grid. Details for the month of January, 2019 are as below:

| Transmission Licensee | Total Delay | Avg. Delay | Max. Delay |
|-----------------------|-------------|------------|------------|
| POWERGRID | 332:52 | 04:41:18 | 95:44 |
| NETC | 00:28 | 00:14 | 00:28 |
| ENICL | - | - | - |

NERLDC requested the forum to restrict the number of non-occ approved shutdown to 5-10%. Forum requested that details of non-occ approved shutdown under construction/PSDF related works may be separately categorized for more clarity.

Regarding non-availing of approved Shut Down, Sr. GM (AM), NERTS requested NERLDC to segregate the shut downs under different category mentioned above. This is pertinent as in many cases of Construction Related approved shut downs the same cannot be availed due to last minute development of ROW issue. Further, the cause of non-availing of approved shut down may please be recorded on real time basis for necessary corrective measures, if any.

Regarding delay in returning Shut Down, Sr. GM (AM), NERTS requested NERLDC to furnish the delay element-wise with cause to be recorded on real time basis. This will help to analyze delay for further corrective measures, if any.

The sub-Committee discussed and approved the proposals received from the constituents regarding transmission elements and generating units for March, 2019-April, 2019 and the same has already been uploaded in website of NERPC.

D.3 Estimated Transmission Availability Certificate (TAC) for the month of November, 2018 to January, 2019:

NETC and POWERGRID have submitted the outage data for the month of November 2018 - January, 2019. So the attributability of outage of the said elements may please be finalized.

NERTS has informed that in order to process the monthly energy billing in time, it is desirable that within 30(thirty) days availability certificate is issued. It is to be deliberated how to issue the availability certificate within 30(thirty) days.

Deliberation in the Meeting:

NERLDC requested NETC & NERTS to submit the data to NERLDC by 5th of the month, so that verification can be completed within 15 days after submission of documents/data as per procedures.

The Sub-Committee noted as above.

Action: Concerned transmission utilities/NERLDC/NERPC

D.4 Joint validation of SCADA data by NERTS & NERLDC

In 153rd OCCM, CGM, NERLDC informed that the data validation has been partially completed. He requested active participation from NERTS so that the same may be completed by Feb'19.

The latest status as intimated by NERLDC: 16 out of 23 stations completed. Details enclosed as **Annexure-D.4**

Deliberation in the Meeting:

The forum requested that the issue may be discussed bilaterally.

The Sub-Committee noted as above.

Action: NERLDC & NERTS

D.5 RGMO performance analysis of instances during January 2019

NERLDC presented a report on RGMO performance for an event on 05th Feb 2019 at 11:57 Hrs when load loss of approx. 869 MW occurred in Northern Region wherein the following generators have not given the desired response:

-Palatana GTG-I -BgTPP Unit – II

And the following generators have given negative response:

-Palatana GTG-II, STG-I/II -Kopili Unit#I

-BgTPP Unit #I

The 153rd OCC forum requested OTPC, NEEPCO and NTPC to analyse the same and revert back. NERLDC requested all ISGS to share unit wise GDAM/ DAS Data for all such events whenever intimation of such events is given by NERLDC via email. If DAS data not submitted by Generators, SCADA data shall be considered for calculation of RGMO response.

Deliberation in the Meeting:

OTPC informed that its operation of plant in RGMO is very difficult and the same has been informed in earlier OCC meeting also. Further, they stated that increasing generation in fraction of second is very difficult as corresponding amount of gas is not supplied automatically. ONGC is operating the pipeline manually and night time is even impossible.

The forum requested OTPC to look into the matter and if not possible, the issue may be informed to NERLDC.

The Sub-Committee noted as above.

Action: OTPC

D.6 Assessment of TTC, TRM & ATC by SLDC on respective Inter-State Transmission Corridor

Deliberation in the meeting:

The forum requested all the SLDCs to carry out the TTC/ATC calculations and decided that SLDC Ar. Pradesh would give presentation in the next OCC.

The Sub-Committee noted as above.

Action: all SLDCs.

D.7 Reliable power supply to Manipur system

For Ensuring reliable power supply to Manipur system, following actions were suggested by NERLDC:

- a. □ 132 kV Jiribam – Jiribam (MA) – Rengpang – Loktak link to be kept in loop
- b. □ Restoration of 132 kV Dimapur – Imphal line
- c. □ Upgradation of 132 kV Kohima – Karong – Imphal (MSPCL) link

Deliberation in the meeting:

Manipur informed the Forum that they would keep in 132 kV Jiribam – Jiribam (MA) – Rengpang – Loktak lin loop after checking the phase sequence. Powergrid informed 132kV Dimapur-Imphal will be restored after June 2019 and regarding Upgradation of 132 kV Kohima – Karong – Imphal (MSPCL) link no discussion due to the absence of Nagaland personnel.

The Sub-Committee noted as above.

D. 8 Scheduling of Unrequisitioned surplus power from ISGS:

In line with CERC Order Dated 17 October 2017 regarding scheduling of unrequisitioned surplus power from the Inter-State Generating Stations and discussions in various forums earlier, URS protocol has been prepared by NERLDC in compliance of the said order. The detailed protocol is available in NERLDC website.

Deliberation in the meeting:

OCC was appraised & for kind information only.

The Sub-Committee noted as above.

D. 9 Instances of non-compliance/violation of IEGC:

Instances of non-compliance of IEGC affecting grid security

- a. Under drawl of States and ISGS during High Frequency (Details are enclosed as **Annexure-D.9.a)**

Deliberation in the meeting:

NERLDC showed list of constituents under-drawing during high frequency and hence requested all the utilities to maintain their drawl as per schedule.

The Sub-Committee noted as above.

Action: All utilities

- b. Non availing of OCC approved shutdown on D-3 basis

Deliberation in the meeting:

NERLDC showed that around 40 percentage of shutdowns are not availed on D-3 basis. NERLDC asked all the utilities to avail shutdown on D-3 basis especially Assam who have been failing to do so lately.

The FORUM advised all concerned to follow the procedure.

Action: All utilities

c. AGBPP schedule and actual generation mismatch.

Deliberation in the meeting:

AGBPP informed the Forum that AGBPP units being small faces problem during the frequent change in schedule. They will look into the matter and try to keep the actual generation same as schedule.

The Sub-Committee noted as above.

Action: NEEPCO

d. Multiple Emergency Shutdowns of Palatana (Details enclosed as **Annexure D.9B**)

Lack of information w.r.t tripping of 132kV Kopili-Khandong-II on 06.03.2019 (Details enclosed as **Annexure D.9C**)

Deliberation in the meeting:

NERLDC showed the incident of 6th March where Palatana requested for Emergency Shutdown and instead of non-confirmation from NERLDC, they reduced day ahead DC. NERLDC also showed other emergency shutdowns availed by Palatana for works which could have been planned in advance. OTPC informed the critical levels for compressor discharge pressure viz: 6mm H₂O column- alarm 8mm- trip shutdown was applied when the level reached 6.2. Since, compressor discharge pressure is critical whose value has reduced drastically, OTPC has to take emergency shutdown. Further, they informed that gas pressure has increase due to pollution.

The forum requested OTPC to apply for shutdown when the level reaches near 6mm i.e. 5.8/5.9. OTPC stated that they will look into the matter and informed accordingly

The Sub-Committee noted as above.

e. Lack of information w.r.t tripping of 132kV Kopili-Khandong-II on 06.03.2019 (Details enclosed as **Annexure D.9C**)

Deliberation in the meeting:

It was observed that at 132kV Kopili-Khandong -II no status was available at local level/NERLDC: After detailed deliberation the forum decided that the availability of data at LDMS/NERLDC to be ensured. Matter was referred to next NeTEST meeting.

The Sub-Committee noted as above.

Action: NERPC

D. 10 Overloading of 132kV Pare-Lekhi line:

To limit the overloading of 132kV Pare-Lekhi line, 132kV Itanagar-Lekhi line has to be kept closed. As reported by SLDC Arunachal Pradesh during real time, they are unable to close the 132kV Itanagar-Lekhi line. Status review of CT ratio of 132kV Itanagar-Lekhi (Study results enclosed as Annexure-D.10)

Deliberation in the meeting:

The issue could not be discussed due to absence of Ar. Pradesh representative.

The Sub-Committee noted as above.

D. 11 Bus Configuration issues for various sub-stations:

Distribution of 132 kV lines in both 132 kV Bus-1 & Bus-2 at Surajmaninagar for reliable operation. Action is to be taken by TSECL.

400kV Bus-A at Ranganadi & 132 kV Transfer Bus at Loktak are not commissioned as per the scheme since inception.

Deliberation in the meeting:

The forum requested TSECL that S.M. Nagar- phase sequence has to be ensured between Bus-2 and transfer Bus. TSECL mentioned that they would revert with timeline.

Regarding 400kV Bus-A at Ranganadi, NEEPCO requested NERPC to write to NEEPCO Management about the non-availability, as it is not proper to operate in single bus.

Regarding transfer bus at Loktak, NHPC informed that the same would be ready by Jun'19. In addition, NERPC informed that they will write a letter for both 400 Bus-A at Ranganadi and 132kV Transfer Bus at Loktak.

NERLDC informed that the difficulties in system operation in case of outage of both buses of critical nodes have been identified and the same is attached as **Annexure-D.11**.

Forum decided that the same will be discussed in detail during the sub-group meeting

The Sub-Committee noted as above.

Action: NERPC, TSECL, NHPC.

D. 12 High voltage in various 400kV nodes:

High voltage of observed in 400 kV nodes of NER grid (Balipara, BNC & RHEP) for 18 minutes w.e.f 23:55 Hrs on 22.02.19 while increasing power order of HVDC BNC – Agra from 500MW to 700MW after de-blocking of Pole-1. Voltage plots of SCADA data

for this period is enclosed as Annexure 10. 400 kV Biswanath Charali - Balipara tripped at 00:07 Hrs on 23.02.19 on Over Voltage in Y-ph at BNC.

High voltage was observed in major 400 kV nodes (phase voltage of 295 kV at Balipara, 303 kV at BNC & 299 kV at RHEP) while tripping of HVDC BNC-APD-Agra pole-1 on 29th Aug'18.-Action plan from NERTS requested with root cause analysis of event on 22.02.19 to avert future incidents

Deliberation in the meeting:

Forum noted the issue and referred to next subgroup meeting for detailed discussion.

Director (O&P), NERPC informed that the next subgroup meeting is scheduled to held on 1st week of Apr'19.

The Sub-Committee noted as above.

Action: NERPC/NERLDC.

D. 13 Reactive power capability/injection of generating stations:

1. □ Tentative schedule for Reactive Power Capability testing of generating units- Tentative date for testing at Pare is 05.04.2019
2. □ Palatana units are not capable of regulating MVAR absorption/injection as the units are in AVR mode. Manual VAR regulation is not possible as informed by Palatana.

Deliberation in the meeting:

The forum requested all generators to strictly follow as per their capability curve and same would be reviewed regularly.

The Sub-Committee noted as above.

Action: All generators.

D. 14 Multiple tripping of 132kV Imphal-Imphal-I:

Multiple tripping of 132kV Imphal-Imphal-I due to downstream fault. Details of tripping are enclosed as **Annexure-D.14.a**

Letter No NERLDC/SO-II/NERTS/2019/2539, Letter No NERLDC/SO-II/NERTS/2019/2818 is enclosed as **Annexure-D.14.b** and **Annexure-D.14.c**-. Action plan from MSPCL requested with root cause analysis to avert future incidents

Deliberation in the meeting:

The forum requested Manipur to follow above suggestions.

The Sub-Committee noted as above.

Action: MSPCL.

D. 15 Improvement of SCADA data availability:

Improvement of SCADA data availability to NERLDC. State wise Comparison of % data availability enclosed as Annexure-D.15, Annexure-D.15.a, Annexure-D.15.b

Deliberation in the meeting:

The forum noted and requested that threadbare will be discussed in next NETeST Meeting.

The Sub-Committee noted as above.

Action: NERPC.

D. 16 Non-availability of relay details at RTAMC:

Full relay details from site is not accessible from RTAMC due to which collection of Relay details after any line tripping are getting delayed for the remotely controlled substation of Powergrid(Details enclosed as Annexure-D.16).

Deliberation in the Meeting:

The forum requested that the issue may be discussed bilaterally.

The Sub-Committee noted as above.

Action: NERLDC & NERTS

D.17 Primary response testing of generators

Deliberation in the Meeting:

- ☐NERLDC informed that the following data w.r.t primary response testing of generators as per format circulated by NLDC is yet to be received from **NHPC & NTPC**.
- ☐**Required Information:** The make, vintage, kind of governor and whether facility for simulated signal input to governor is there or not
- ☐NTPC & NHPC agreed to submit the data by Mar'19.

The Sub-Committee noted as above.

Action: Concerned Utilities

D.18 Operating Procedure for the year 2019

Deliberation in the Meeting:

NERLDC informed that the Draft Operating Procedure for the year 2019 is mailed to all Utilities. It was requested to all utilities to give comments by 30th April'19, if any.

For kind information.

D.19 Nodal officer for Disaster Management

Deliberation in the Meeting:

Updated Contact Details of Disaster Management Nodal Officers of Power Utilities of NER is attached as **Annexure D.19**.

The Sub-Committee noted as above.

D.20 Submission of Data for Wind Turbine Generator:

Submission of ***States Wind Turbine Generator (WTG)-wise data*** pertaining to Low Voltage Ride Through (LVRT) as directed by Hon' CERC vide ROP in Petition no. 237/MP/2017.

Deliberation in the Meeting:

NERLDC informed that forum that format for submission of data was circulated vide letter NERLDC/SO-II/2855 dated 06.03.19. Format for submission of data is attached as **Annexure D.20**. It was requested to all SLDCs to submit data as per format by 30th April'19.

The Sub-Committee noted as above.

Action: Concerned Utilities

Additional Agenda:

D.21 First time Charging of New Elements

Proposal for furnishing technical parameters required for dynamic modelling for start-up power and first-time synchronization of generators in standard formats.

Deliberation in the Meeting:

NERLDC informed that draft standard format for furnishing technical parameters required for dynamic modelling for start-up power and first-time synchronization of generators was circulated to utilities vide email. It was requested to all utilities to give comments by 30th April'19, if any. Standard format for furnishing technical parameters required for dynamic modelling is attached as **Annexure-D.21**.

Date & Venue of next OCC meeting

It is proposed to hold the 155th OCC meeting of NERPC on second week of April, 2019. However, the exact date and venue will be intimated in due course.

The meeting ended with thanks to the Chair.

Annexure-I**List of Participants in the 154th OCC Meeting held on 13rd March, 2019**

| SN | Name & Designation | Organization | Contact No. |
|-----|---|--------------------|-------------|
| | No Representatives | Ar. Pradesh | - |
| 1. | Sh. K.N. Adhikary, CGM, SLDC | Asam | 09954074123 |
| 2. | Sh. Dipesh Ch. Das, AGM (LDC) | Assam | 09954110254 |
| 3. | Sh. Bimal Ch. Borah, AGM, SLDC | Assam | 09475119248 |
| 4. | Sh. N. Hazarika, AGM, HQ | Assam | 09435386310 |
| 5. | Sh. P.K. Baishya, AGM (Com) APDCL | Assam | 09864504749 |
| 6. | Sh. S.P. Rabha, AM (Com) APDCL | Assam | 08402981282 |
| 7. | Sh. R. Das, AM, SLDC | Assam | 09435097009 |
| 8. | Smti. L. Ritu, DGM (SO), SLDC | Manipur | 09612882984 |
| 9. | Smti. K. Steela, DGM (Comml), SLDC | Manipur | 08730831103 |
| 10. | Sh. B. Nikhla, EE (SP) | Meghalaya | 09436314163 |
| 11. | Sh. D.J. Lyngdoh, EE, SLDC | Meghalaya | - |
| 12. | Sh. W. Khyriem, EE, GSPD | Meghalaya | 09856007107 |
| 13. | Sh. D. Kharmawphlang, AE, SLDC | Meghalaya | - |
| 14. | Sh. Marc N. Tariang, JE (System Protection) | Meghalaya | 07005620013 |
| 15. | Sh. F. Lalrinpuia, SE | Mizoram | 09436143080 |
| | No Representatives | Nagaland | - |
| 16. | Sh. Anil Debbarma, DGM, SLDC | Tripura | 09612589250 |
| 17. | Sh. Debabrata Pal, Sr. Manager (Comml.) | Tripura | 09436500244 |
| 18. | Sh. Joypal Roy, Sr. Manager (E/M) | NEEPCO | 09435577726 |
| 19. | Sh. V. Suresh, CGM | NERLDC | 09449599156 |
| 20. | Sh. R. Sutradhar , DGM (MO) | NERLDC | 09436302714 |
| 21. | Sh. Sakal Deep, Engineer | NERLDC | 09774528218 |
| 22. | Sh. Kamal K.Kumar, Dy. Manager | NERLDC | 09402187490 |
| 23. | Sh. Bornali Nath, Engineer | NERLDC | 08414927752 |
| 24. | Sh. Keshab Borah, Engineer | NERLDC | 07002323608 |
| 25. | Sh. Jerin Jacob, Asst. Manager | NERLDC | 09602120113 |
| 26. | Sh. P.Kanungo, Sr. GM (AM) | PGCIL | 09436302823 |

| | | | |
|-----|---|-------|-------------|
| 27. | Sh. Pulak Deka, Manager (M) | NHPC | 09435187838 |
| 28. | Sh. Sanjib Pal, AM (Operation) | OTPC | 09436583737 |
| 29. | Sh. Subhajit Ganguly, Sr. Executive (Elec.) | OTPC | 07980010258 |
| 30. | Sh. Samir Haloi, DGM (Comml.) | NTPC | 09437561689 |
| 31. | Sh. Anoop Kumar, Sr. Manager | NTPC | 09650996026 |
| 32. | Sh. Kangkan Paul, Dy. Manager, BgTPP | NTPC | 09435029230 |
| 33. | Sh. D. Basu | PRDC | - |
| 34. | Sh. Debabrata Paul | PRDC | - |
| 35. | Sh. K. Jagan Mohan, JD | CDAC | 09739109842 |
| 36. | Sh. P.K. Mishra, Member secretary | NERPC | 09968380242 |
| 37. | Sh. B. Lyngkhai, Director (O&P) | NERPC | 09436163419 |
| 38. | Sh. S. Mukherjee, AD | NERPC | 08794277306 |



Annexure-B.2 (a)

उ.पू.क्षे ग्रिड प्रदर्शन

NER GRID PERFORMANCE

For Month: February 2019

NORTH EASTERN REGIONAL LOAD DESPATCH CENTRE

POSOCO, SHILLONG

Contents

Highlights

Frequency
Profile

Voltage
Profile &
Issues

Cross Border
Transaction

Generation
Pattern

Inter
Regional
Exchange

Energy
Availability
of States

Maximum
Demand Met

Drawl
Pattern of
States

Violation
Messages

STOA
Transactions

Water Level
of reservoir

Contents

Energy
Content of
HEPs

GD & GI
counts

Agenda



Highlights for the month of February 2019

- 1. BgTPP Successful completion of Trial run (graph link).**
- 2. Assam LTA from Mouda II.**
- 3.**

[BACK](#)

Some Important Points

1. URS protocol in line with CERC letter dated 21.02.2019 in compliance of order dated 17.10.2017.(scan copy, 2017 order and protocol copy).
2. Frequent oscillation in AGTCCPP. (C.20)
3. Protocol for Reliable operation of NER grid.

Some Important Points

3. Central Electricity Regulatory Commission(Terms and Conditions of Tariff) Regulations, 2019 has been issued. These regulations shall come into force on 01.04.2019 and will be valid from 1.4.2019 to 31.3.2024. Some highlights of the regulations:
- In case of Thermal generating stations rate of return on equity shall be reduced by 0.25% in case of failure to achieve the ramp rate of 1% per minute and an additional rate of return on equity of 0.25% shall be allowed for every incremental ramp rate of 1% per minute
 - The capacity charges for High demand season(period of three months) and low demand season(period of nine months) as well as for peak hours and off-peak hours will be different to be implemented from 01.04.2020.

Frequency Profile for the month of February'19:

% OF FREQUENCY WITHIN & OUT SIDE THE IEGC BAND

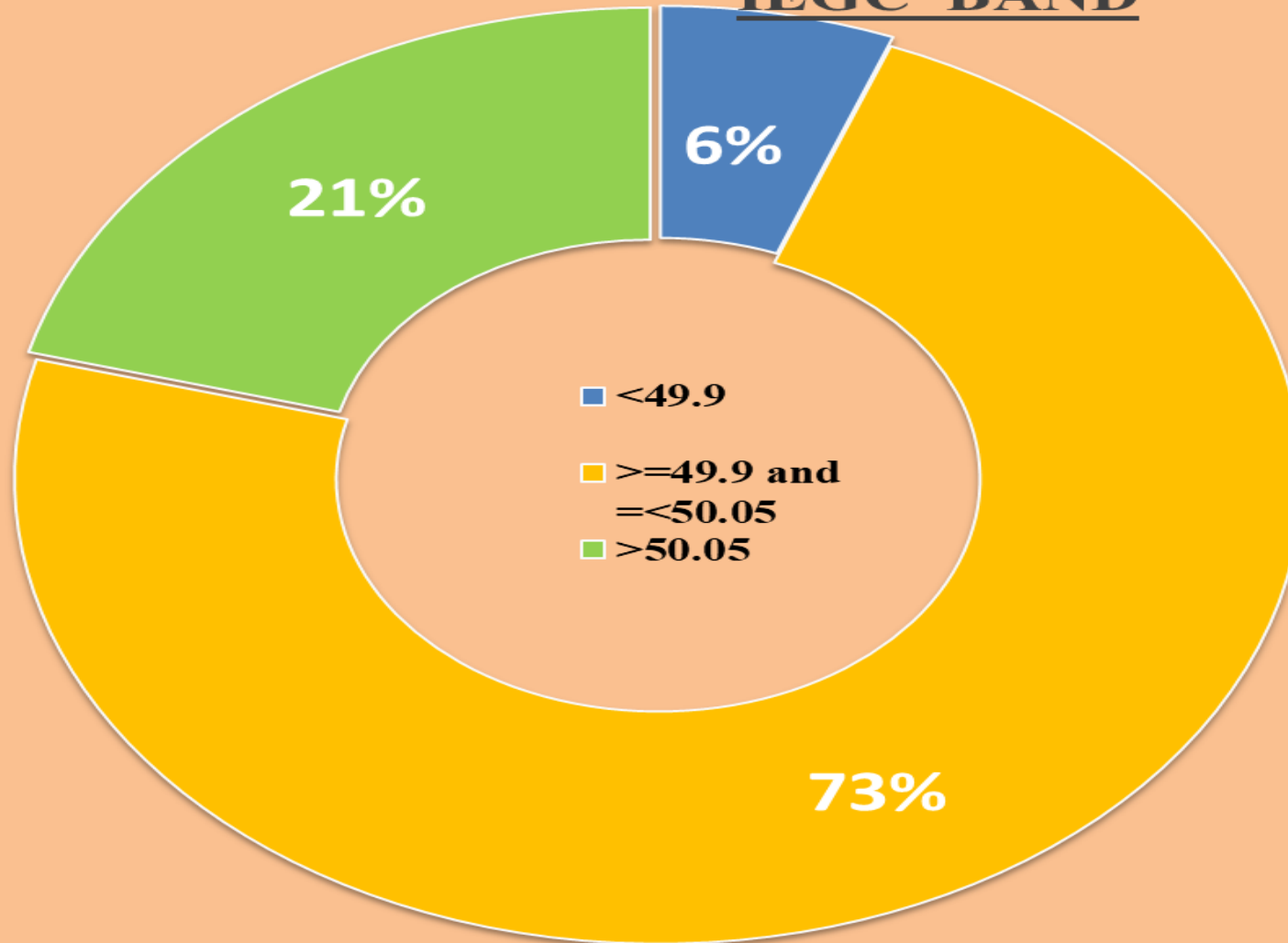

Daily Frequency Profile

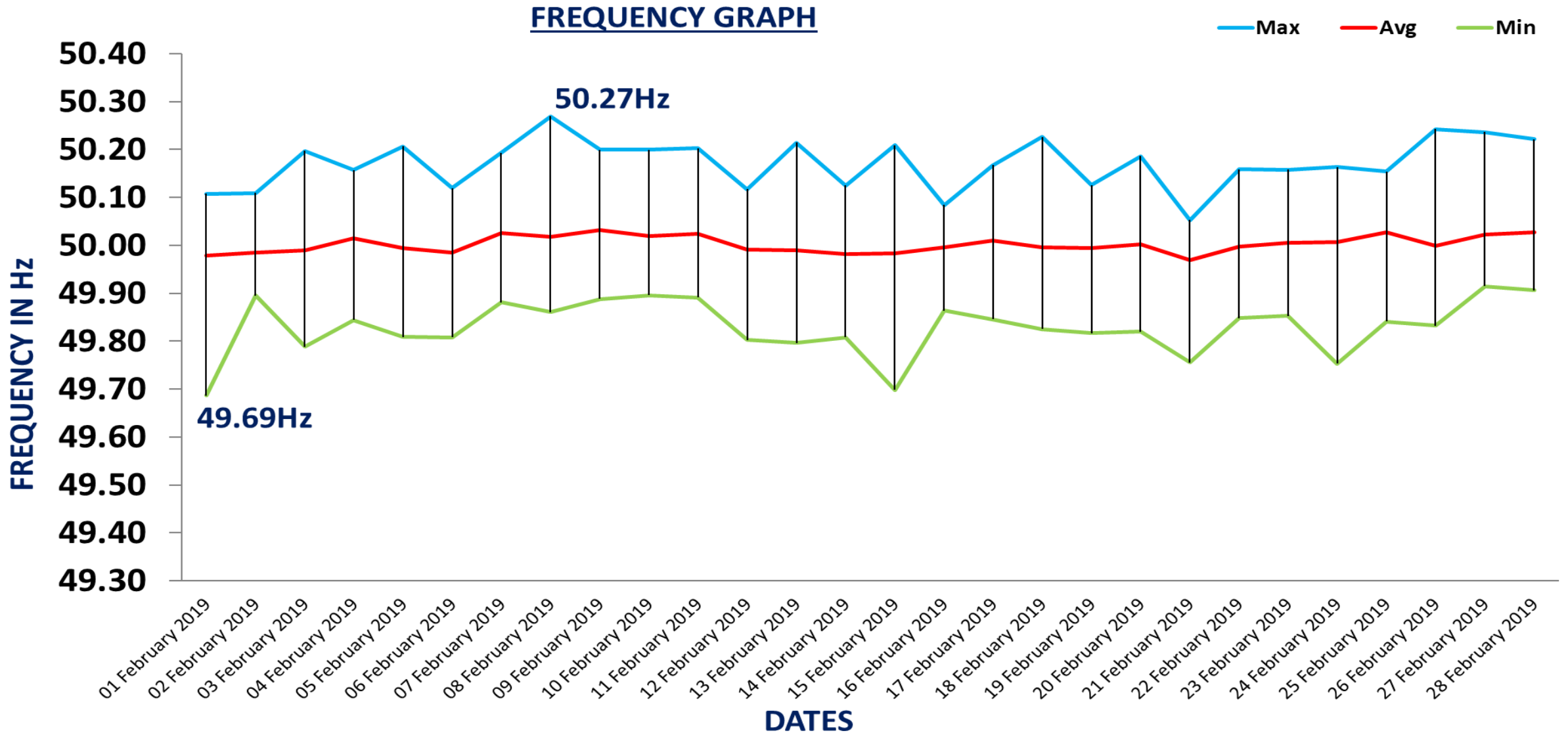

Voltage Profile Issue Voltage Deviation Index (outside IEGC range) in % (Agenda)



| Sl No. | Name of 400 kV Node | Feb'18 | Feb'19 |
|--------|-------------------------|--------|--------|
| 1 | Azara (AEGCL) | 0.000 | 0.000 |
| 2 | Balipara (PG) | 0.000 | 0.003 |
| 3 | BgTPP (NTPC) | 0.000 | 0.004 |
| 4 | Biswanath Chariali (PG) | 0.000 | 0.000 |
| 5 | Bongaigaon (PG) | 0.000 | 0.000 |
| 6 | Byrnihat (MePTCL) | 0.003 | 0.011 |
| 7 | Misa (PG) | 0.011 | 0.115 |
| 8 | Palatana (OTPC) | 0.135 | 0.000 |
| 9 | Ranganadi (NEEPCO) | 0.094 | 0.301 |
| 10 | Silchar (PG) | 0.008 | 0.000 |
| 11 | Imphal (PG) | - | 0.000 |

Number of 400 kV Lines opened on Overvoltage for Feb'19

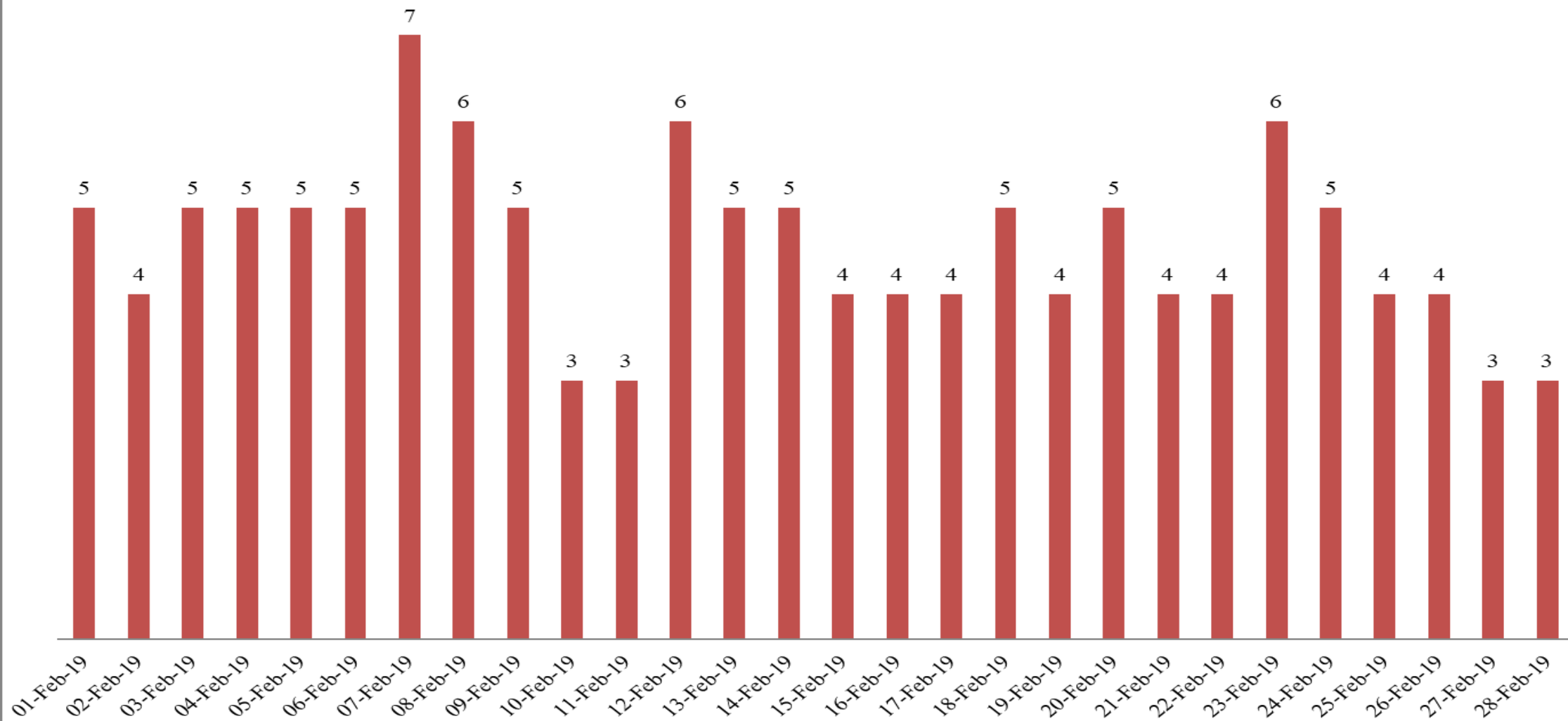

Number of Hours 400 kV Lines kept opened due to Over Voltage during Feb'19

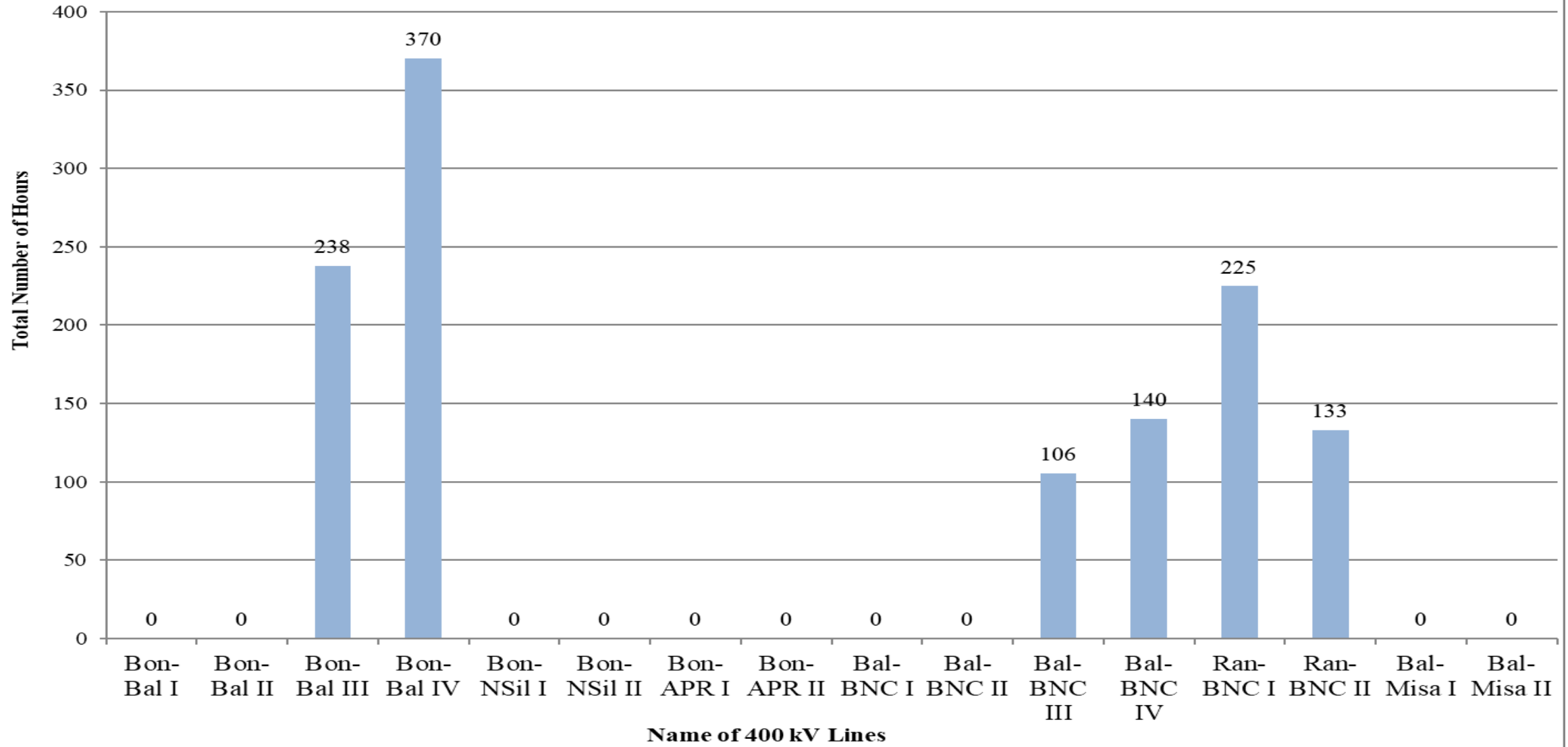

Bon-Bongaigaon, Bal-Balipara, Ran-Ranganadi, BNC-Biswanath Charali, APR-Alipurduar, NSil- NewSilliguri

■ Maximum No. Lines Opened in a Day due to Over Voltage

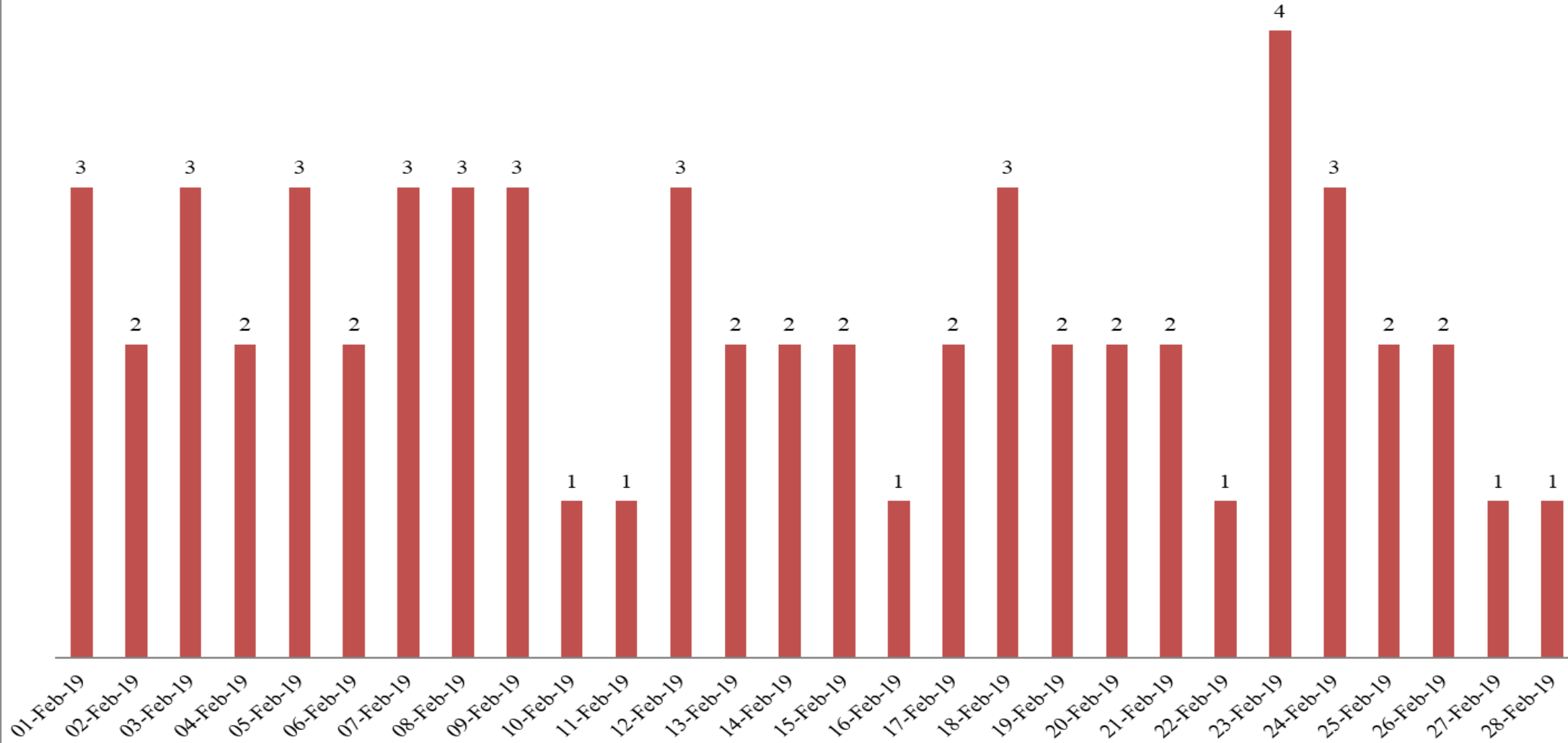

Cross Border Transactions (in MU)

| Net Inter-Country Power Exchange(in MU) | |
|--|-----------|
| Import (+)/ Exp (-) by Bhutan | 11.750 |
| Drawal by Bangladesh | 64 |
| Drawal by Myanmar | 0.5178524 |

Comparison of Generation Pattern (MU)

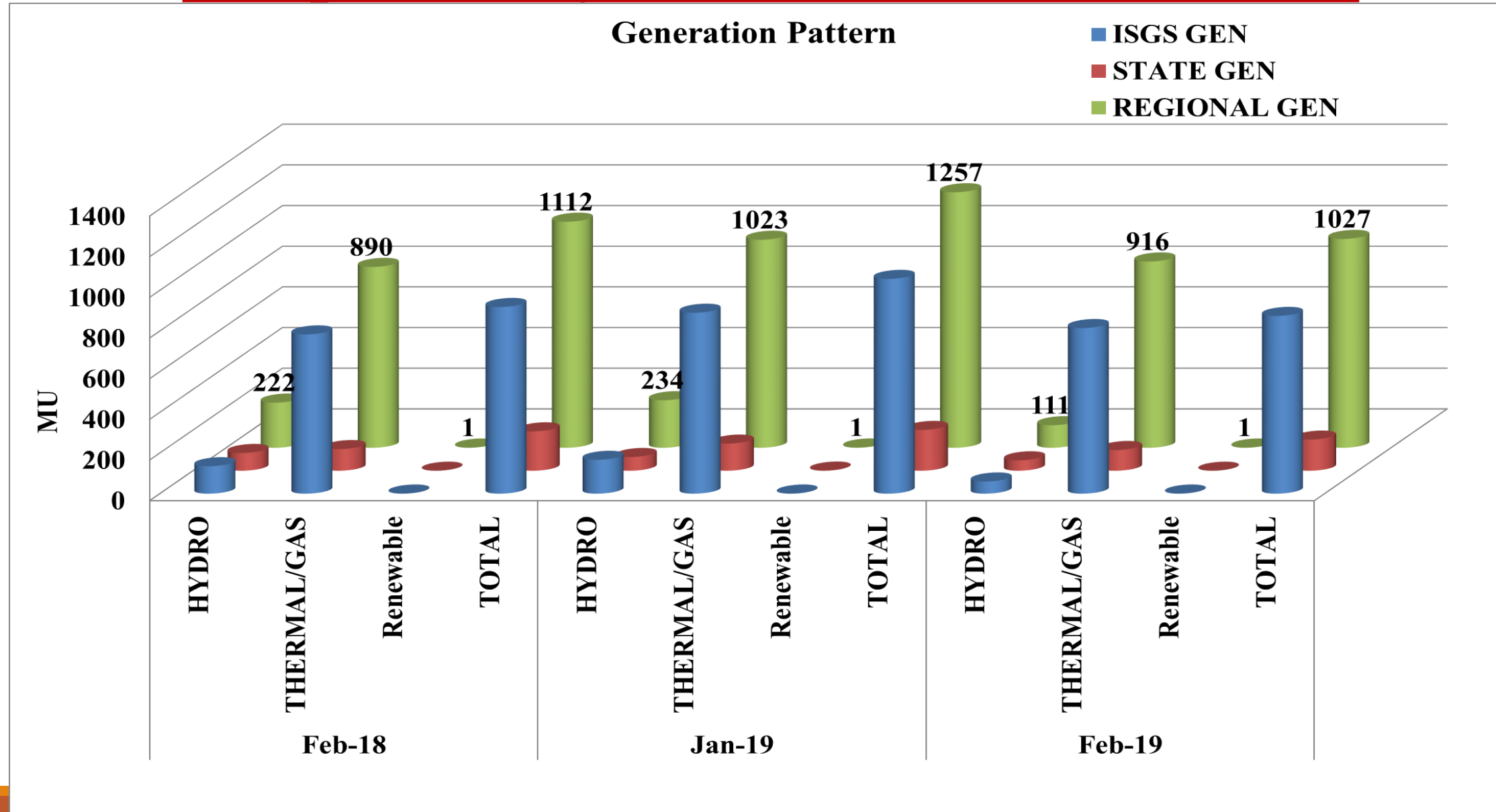

Comparison of Inter – Regional Exchange in MU

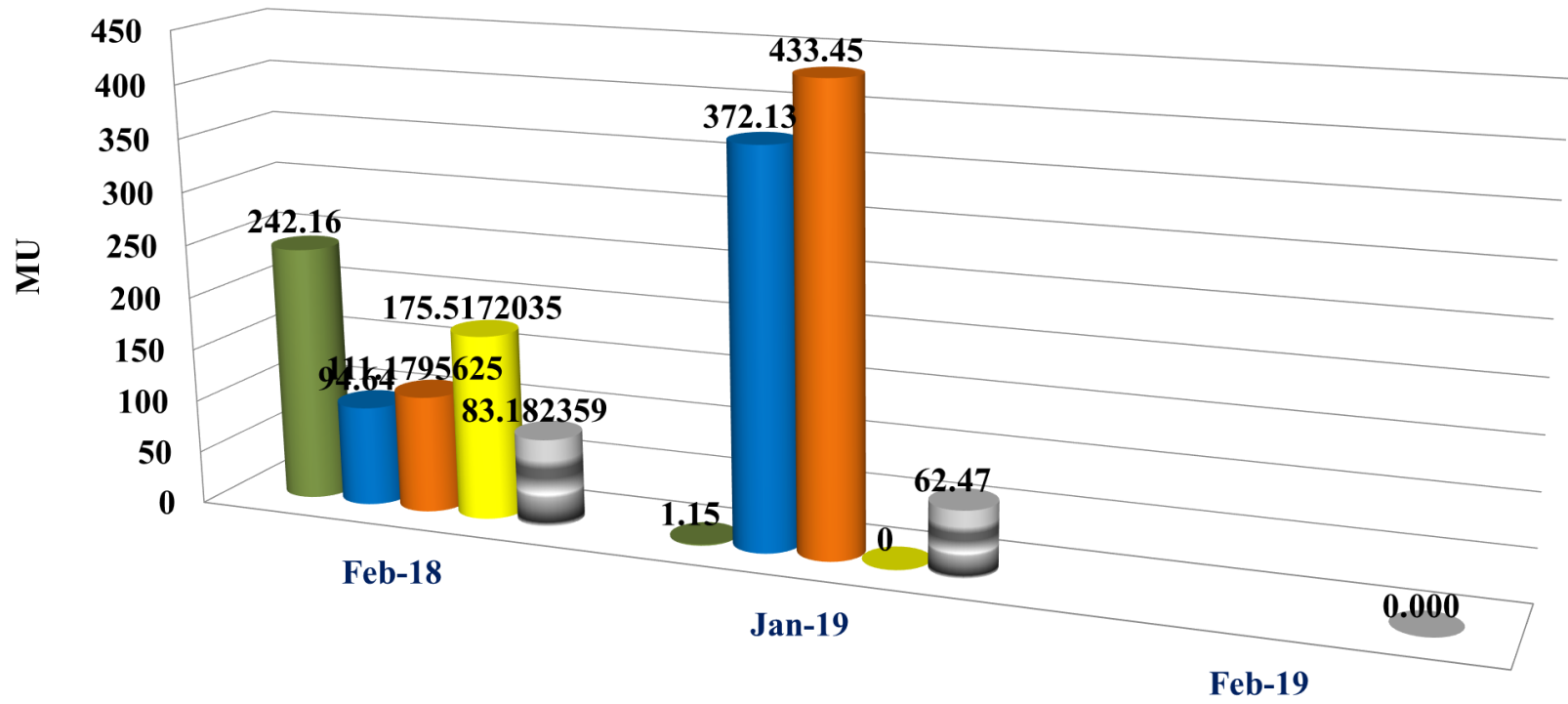

| | Feb-18 | Jan-19 | Feb-19 |
|---------------------------|-------------|--------|--------|
| ■ ER-NER | 242.16 | 1.15 | |
| ■ NR-NER | 111.1795625 | 433.45 | |
| ■ Net Import(+)/Export(-) | 83.182359 | 62.47 | 0.000 |

Maximum Demand Met of states for January'19



| Name of Constituents | Maximum Demand Met (MW) in February'19 | Maximum Demand Met (MW) in January'18 | Maximum Demand Met (MW) in February'18 |
|-------------------------------|--|---------------------------------------|--|
| Ar Pradesh | 148.0 | 124.0 | 128.0 |
| Assam | 1440.0 | 1468.0 | 1481.0 |
| Manipur | 194.0 | 215.9 | 190.7 |
| Meghalaya | 356.0 | 372.2 | 311.0 |
| Mizoram | 109.0 | 118.9 | 94.0 |
| Nagaland | 132.0 | 137.6 | 122.0 |
| Tripura(Excluding Bangladesh) | 231.0 | 222.9 | 237.0 |
| Region(Excluding Bangladesh) | 2514.0 | 2552.0 | 2487.0 |
| Max Drawal by Bangladesh | 155.0 | 173.8 | 153.6 |
| Max Drawal by Myanmar | 4.0 | 1.5 | 1.4 |

Violation Message Summary of January 2019

| Constituents | Deviation Violation Message | | | Frequency Violation Message | | |
|--------------|-----------------------------|-----------|-------|-----------------------------|-----------|-------|
| | Alert | Emergency | Total | Alert | Emergency | Total |
| AP | 0 | 0 | 0 | 9 | 1 | 10 |
| Assam | 9 | 1 | 10 | 25 | 1 | 26 |
| Manipur | 0 | 0 | 0 | 11 | 1 | 12 |
| Meghalaya | 2 | 0 | 2 | 24 | 1 | 25 |
| Mizoram | 0 | 0 | 0 | 16 | 2 | 18 |
| Nagaland | 0 | 0 | 0 | 19 | 2 | 21 |
| Tripura | 2 | 1 | 3 | 17 | 1 | 18 |
| AGBPP | 0 | 0 | 0 | 0 | 0 | 0 |
| AGTCCPP | 0 | 0 | 0 | 0 | 0 | 0 |
| RHEP | 0 | 0 | 0 | 0 | 0 | 0 |
| KOPILI | 0 | 0 | 0 | 0 | 0 | 0 |
| KHANDONG | 0 | 0 | 0 | 0 | 0 | 0 |
| KOPILI –II | 0 | 0 | 0 | 0 | 0 | 0 |
| DHEP | 0 | 0 | 0 | 0 | 0 | 0 |
| LOKTAK | 0 | 0 | 0 | 0 | 0 | 0 |
| BgTPP | 0 | 0 | 0 | 0 | 0 | 0 |
| PALATANA | 0 | 0 | 0 | 2 | 0 | 2 |
| PARE | 0 | 0 | 0 | 0 | 0 | 0 |

STOA Transactions by the States

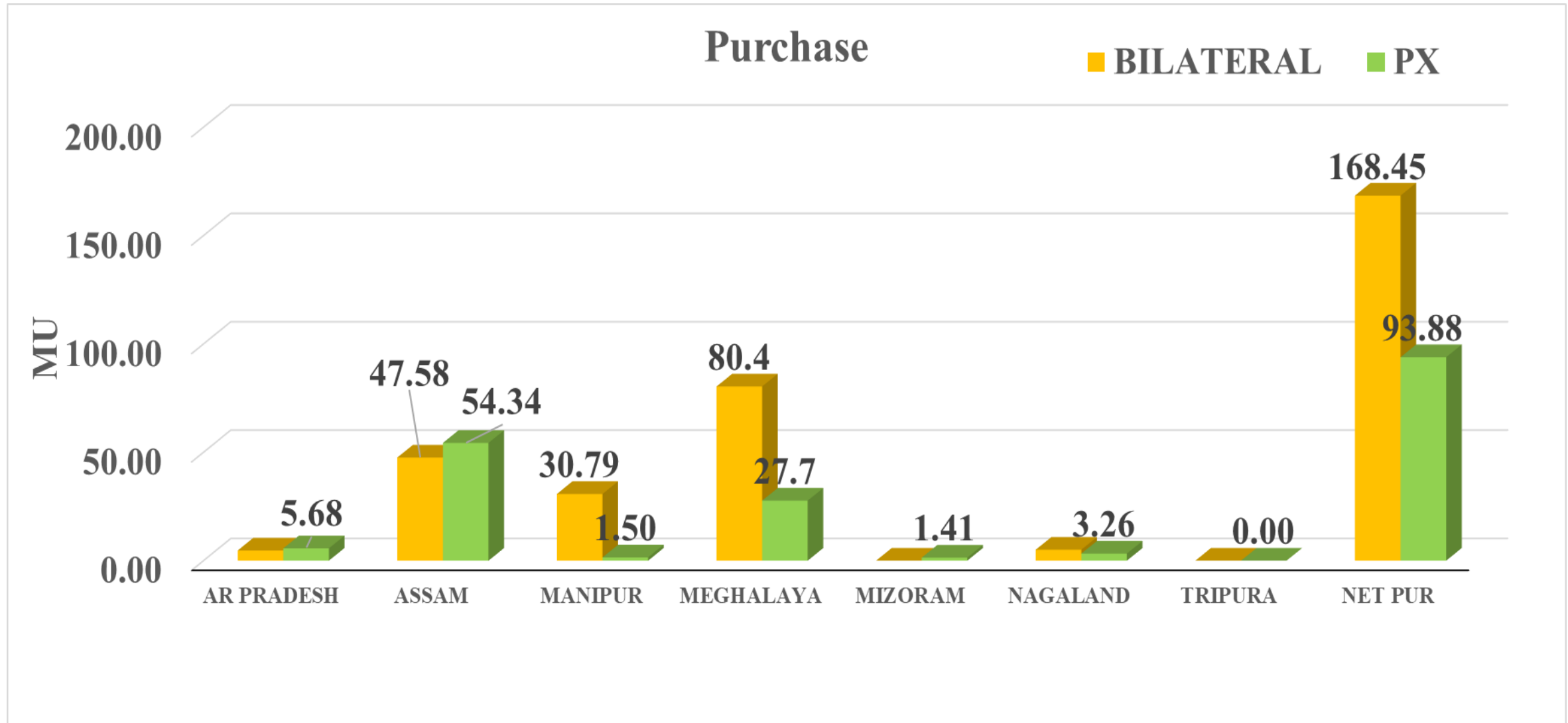

STOA Transactions by the States

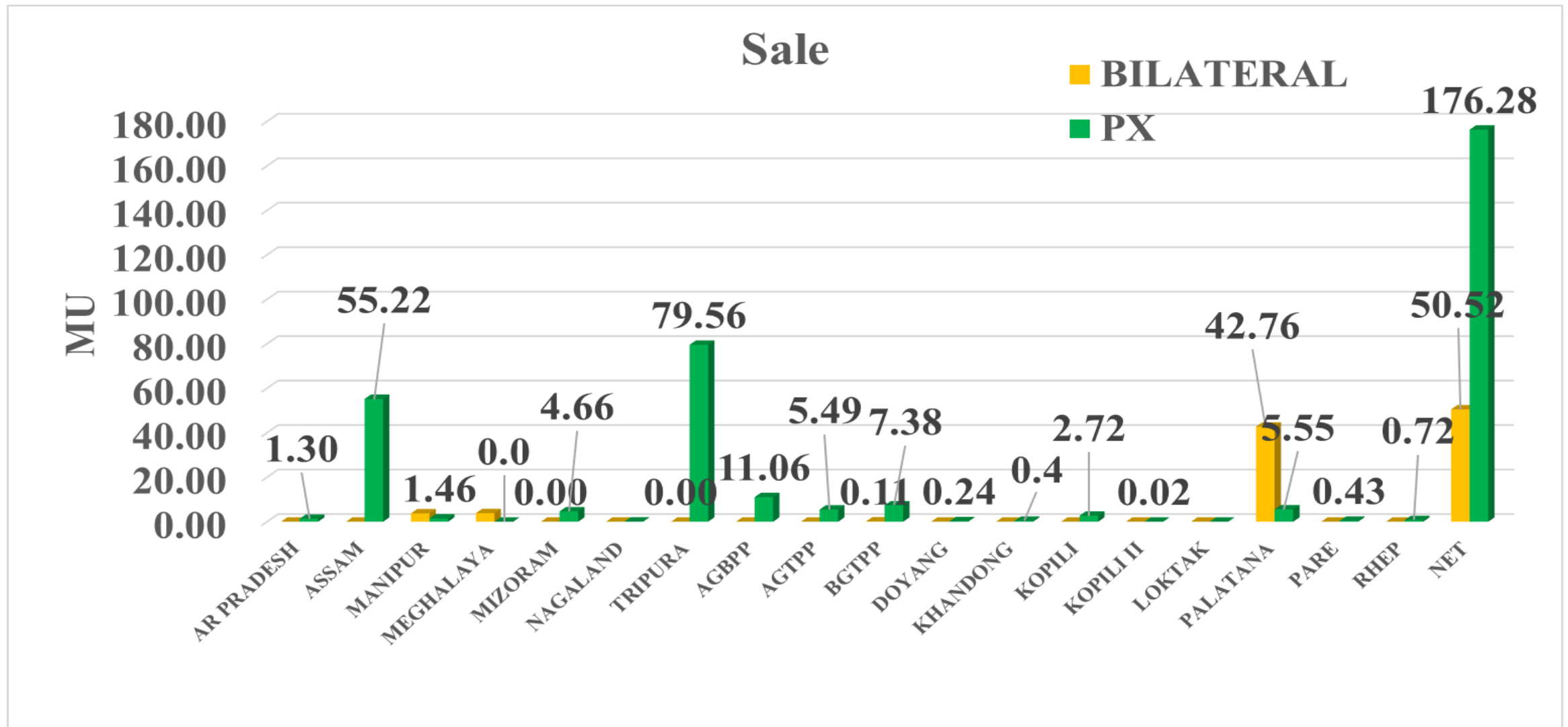

Water Level of Reservoirs in NER

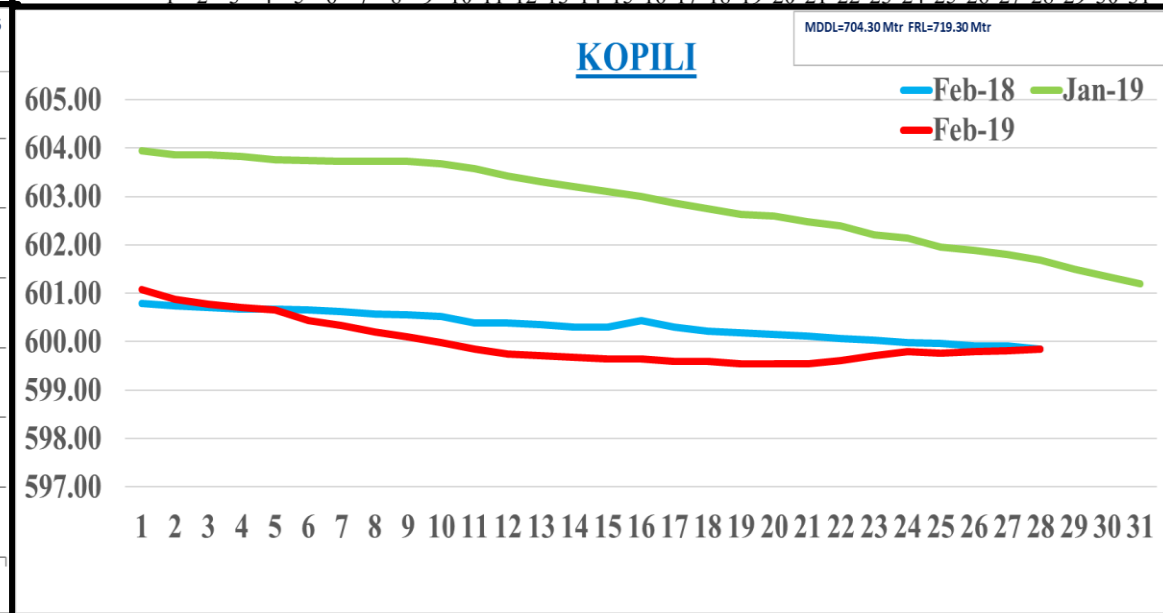
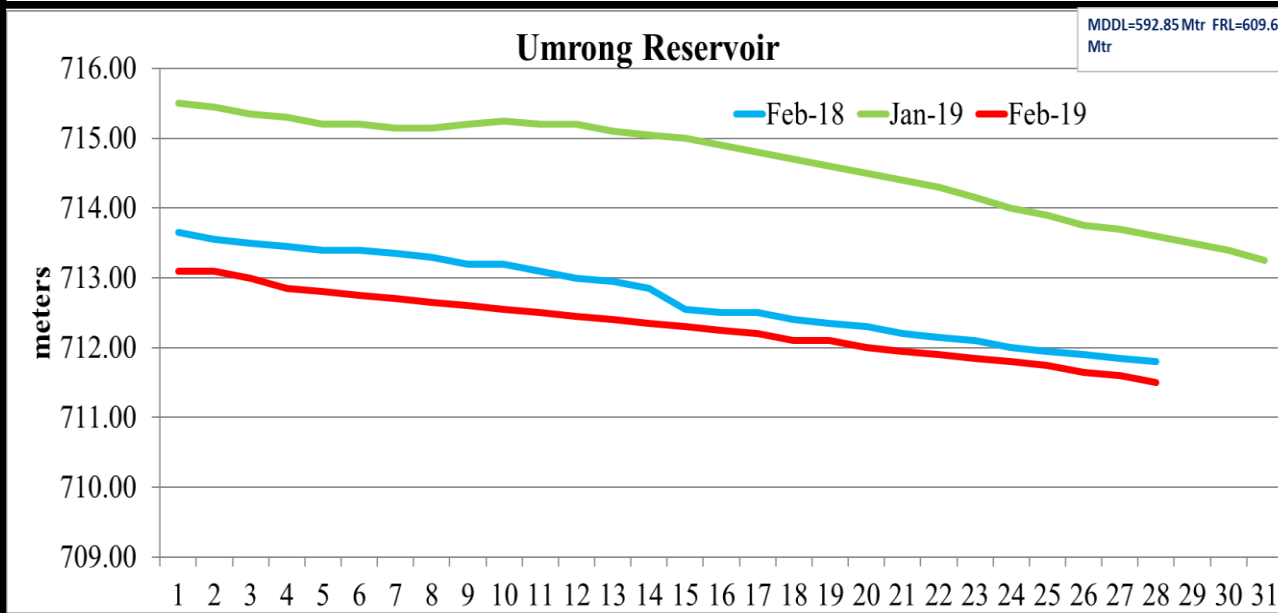
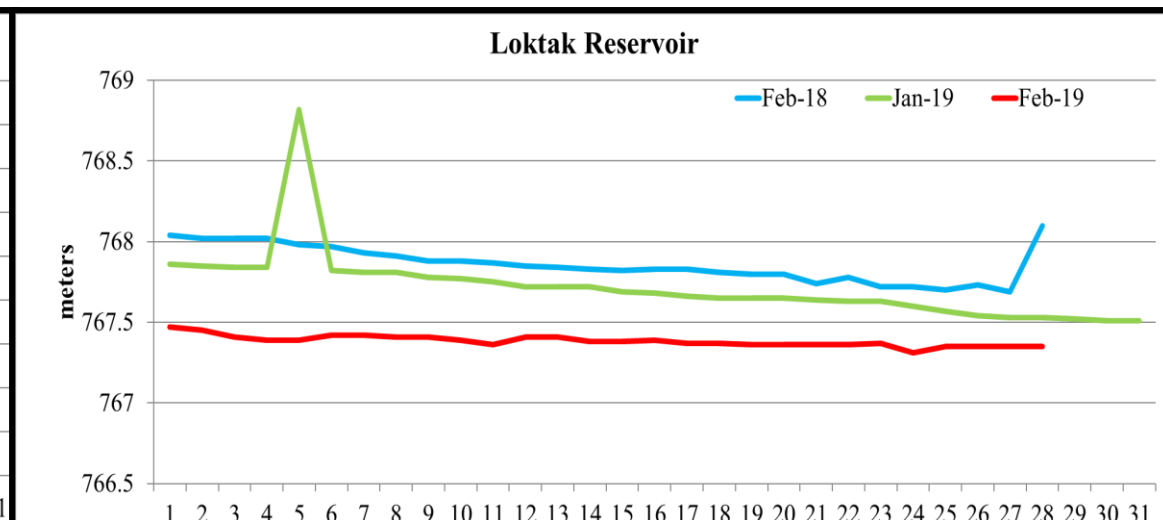
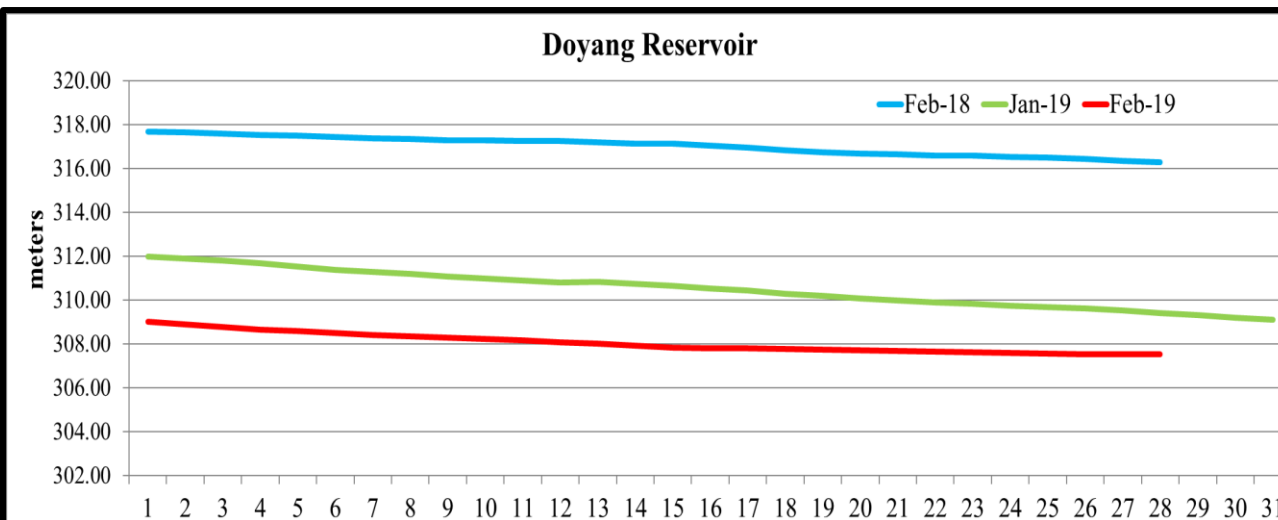

Energy Content of Hydro Plants

| Plants | Reservoir Level in meters | MU Content | Present DC (MU) | No of days as per current Generation |
|---------------------------------|----------------------------------|-----------------------|------------------------|---|
| Khandong + Kopili STG II | 710.4 | 8.03 | .258+0 | 31 |
| | | | 0.258 | |
| Kopili | 599.7 | (28.9+ 4x8.03) | 1.098 | 56 |
| | | 61.02 | | |
| Doyang | 307.341 | 1.3 | 0.048 | 27 |
| Loktak | 768.45 | 240 | 0.244 | 984 |

Details of Grid Disturbance / Grid Incidents

GD & GI Count for February'19

| Sl. No. | Category of GD | Total Counts |
|----------------|-----------------------|---------------------|
| 1 | GI 1 | 2 |
| 2 | GI 2 | 5 |
| 3 | GD 1 | 8 |
| 4 | GD 2 | 0 |
| 5 | GD 3 | 0 |
| 6 | GD 4 | 0 |
| 7 | GD 5 | 0 |

Non receipt of D-3 availing request for 152nd OCCM approved shutdowns

| |
|--|
| Total no. of SD approved |
| 136 |
| Nos. of SD availed on D-3 basis |
| 61 |
| Nos. of SD not availed on D-3 basis |
| 25 |
| Nos. of SD not availed |
| 50 |

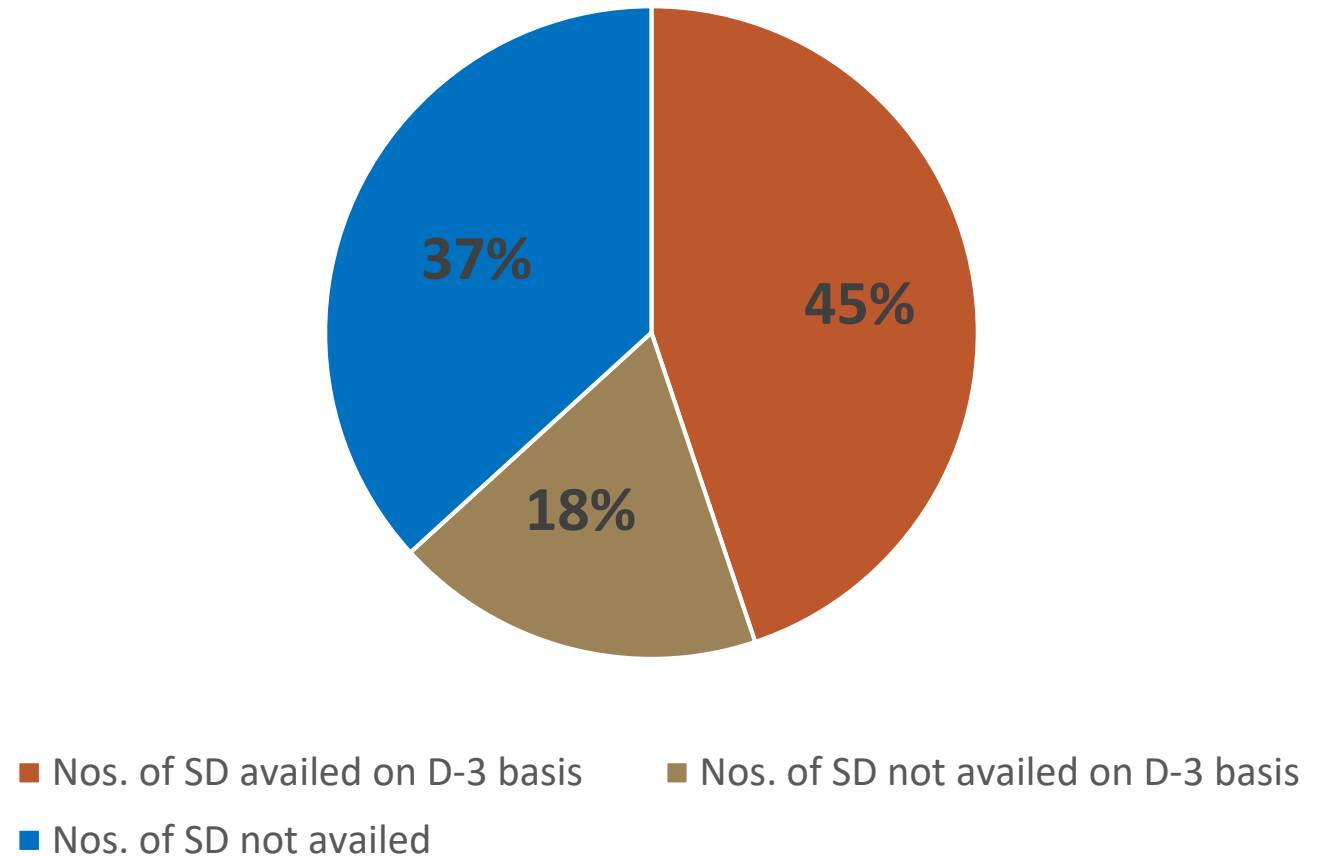

High percentage of non-OCC approved shutdown request

| Total no. of OCC approved SD | Nos. of Non-OCC approved shutdown |
|------------------------------|-----------------------------------|
| 136 | 37 |

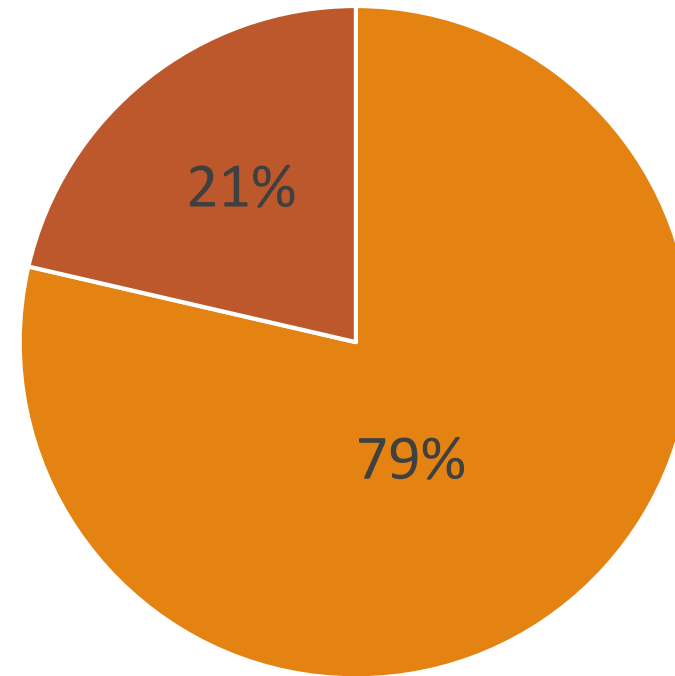

■ Total no. of OCC approved SD ■ Nos. of Non-OCC approved shutdown

Inordinate Delay for January 2019

| Transmission Licensee | Total Delay (in Hrs) | Avg. Delay (in Hrs) | Max. Delay (in Hrs) |
|------------------------------|-----------------------------|----------------------------|----------------------------|
| POWERGRID | 332:52:00 | 04:41:18 | 95:44:00 |
| NETC | 00:28:00 | 00:14:00 | 00:28:00 |
| ENICL | - | - | - |

Agenda 2. a.b.f Progress of activities / decisions of 152nd OCC meeting of NERPC

- **Status Review: Design & implementation of SPS for Outage of 400 kV Bus – I & II at Silchar (PG) and Outage of any one circuit of 400 kV Bongaigaon – BgTPP. Study results in [Annexure SPS](#)**
- **Schedule for special meeting on review of existing SPSs & devising new SPSs as per present requirement of NER grid –**
 - **Action: NERPC & all Regional Entities requested.**
- **Organizing PCC Meeting on Bi-Monthly Basis –**
 - **Tentative date for next meeting**

Agenda 3. Preparedness for secured grid operation during High Wind and Monsoon Season

- Entire NER generally experiences heavy windy weather followed by rain from the month of March onwards resulting tripping of elements due to lightning, Grid disturbances & Grid Incidents, load crash and etc.
- Statistics for the last two years is as follows and Category wise tripping statistics is shown in Table in *next slide*

Last two years category wise tripping

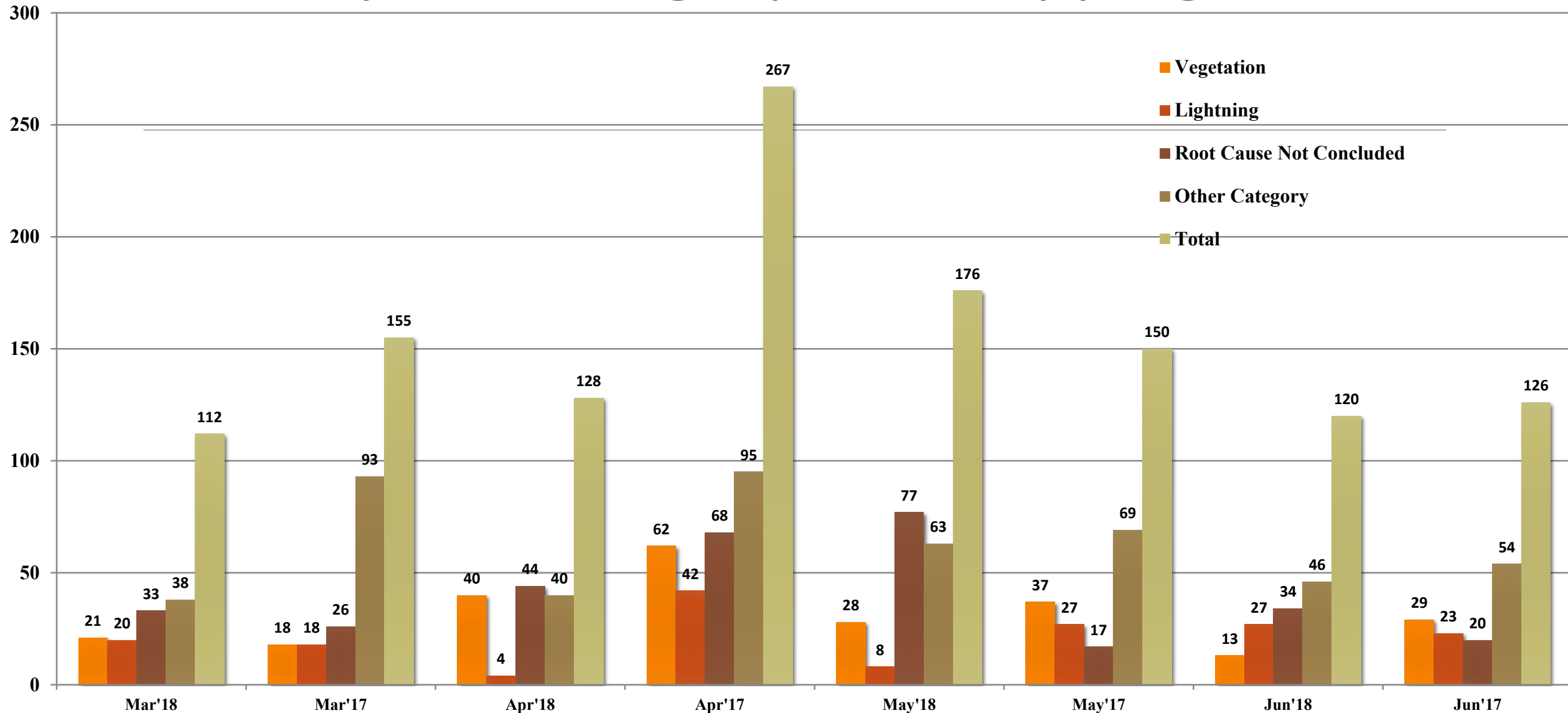

Agenda 3. Preparedness for secured grid operation during High Wind and Monsoon Season – Contd.

- **To minimise such instances, all the transmission utilities requested for thorough patrolling & clearing of vegetation (especially Bamboos) ensuring adequate RoW of all transmission elements.**
- **All utilities are requested to furnish the schedule (say by 25th February'19) facilitating proper monitoring by RPC as per direction of CERC**
- **All substations, generating stations and control centers of state power systems are requested to maintain alert status**

Agenda 3. Preparedness for secured grid operation during High Wind and Monsoon Season – Contd.

- **As a part of this preparedness, following activities are suggested**
 - **Appropriate action for load – generation balance.**
 - **Keep frequency, line loading and voltage within prescribed limit.**
 - **During High Frequency, generation back down of machines within state power system.**
 - **During High Voltage, keep all ‘Capacitors’ out of service and all ‘Bus Reactors’ in service. Use ‘Line Reactors’ as ‘Bus Reactors’ after discharging the line.**
 - **During High Voltage, absorption of ‘Reactive Power’ by generating unit should be according to ‘capability curves’.**
 - **Operation of Synchronous Condenser Mode in Hydro machine, if possible.**
 - **Maintain alertness on all substations, generating stations and control centers of state power systems**

Instances of non-compliance / violation of IEGC

Agenda 4 a. Opportunity SD of 132 kV Salakati – Gelephu on 22.01.19 without prior intimation to NERLDC by NERTS



nerldc shillong <nerldccontrolroom@gmail.com>

132kV Salakati-Gelephu regarding

2 messages

nerldc shillong <nerldccontrolroom@gmail.com>

Tue, Jan 22, 2019 at 4:18 PM

To: nerts cpcc <nerts_cpcc@powergrid.co.in>

Cc: MS NERPC <nerpc@ymail.com>, V Suresh <vsuresh@posoco.in>, kaikhochin valte <kaikhochin@gmail.com>, S C De <scde@posoco.in>, Amresh Mallick <amareshmallick@posoco.in>

Sir,

Planned Shutdown of 132 kV Salakati-Gelephu T/L availed by Bhutan at 09:27 hrs dated 22-01-2019 for general maintenance work. The said S/D was withdrawn by Bhutan at 15:48 hrs vide charging code (Bhutan-136,NLDC-1197). Accordingly RLDC charging code 6150 was issued at 15:49 hrs for charging of line. However, it is come to know that POWERGRID availed opportunity S/D for testing of bay equipment's without intimating NERLDC, Shillong which is the great concern from safety and system security point of view.

Therefore, it is requested not to avail opportunity S/D in future without prior intimation to NERLDC.

You are requested to bring the said line into service at the earliest. **Matter may be treated as most urgent.**

Thanking You.

सादर /Regards,

B.Swagairy

पाली प्रभारी/Shift-In-Charge

उत्तर पूर्वी भार प्रेषण केंद्र शिलांग

North Eastern Load Dispatch Centre Shillong



Agenda 4 b. Attending rectification work of synchronizing circuit of Misa-1 Tie bay at Balipara on 15.01.19 without prior intimation to NERLDC by NERTS

Agenda 4 c. Over Drawal of States during Low Grid Frequency (outside IEGC Band)

| Date | Frequency(Hz) | States | Schedule(MW) | Actual(MW) | Overdrawal MW |
|------------|---------------|-------------------|--------------|------------|---------------|
| 22.01.2019 | 49.68 | Arunachal Pradesh | 82 | 109 | 26.45 |
| | | Assam | 726 | 826 | 100.76 |
| 02.01.2019 | 49.77 | Assam | 725 | 737 | 12.06 |
| | | Meghalaya | 276 | 290 | 14.20 |
| | | Tripura | 42 | 76 | 33.83 |
| | | Manipur | 169 | 184 | 15.22 |
| 05.01.2019 | 49.77 | Arunachal Pradesh | 64 | 82 | 18.03 |
| | | Assam | 644 | 677 | 33.05 |
| | | Tripura | 48 | 60 | 12.31 |
| | | Manipur | 96 | 117 | 20.35 |

Network Issues

Agenda 5.Overloading of inter-state lines to the main NER Grid/ All India Grid

| Sl. No. | Date | Time | Line/ICT | Affected States | Overloading |
|---------|------------|-------|---------------------------|-----------------|-------------|
| 1 | 16/01/2019 | 17:41 | 132 kV Badarpur-Panchgram | Assam | 72 MW |
| 2 | 16/01/2019 | 17:44 | 132 kV Melriat-Zuangtui | Mizoram | 74 MW |
| 3 | 27/07/2018 | 20:17 | 132 kV Kamalpur-Rangia | Assam | 79.5 MW |
| 4 | 16/07/2018 | 15:15 | 125 MVA ICT-I Palatana | Tripura | 123 MW |
| 5 | 25/07/2018 | 18:59 | 125 MVA ICT-I Palatana | Tripura | 121 MW |
| 6 | 25/07/2018 | 18:59 | 125 MVA ICT-II Palatana | Tripura | 115 MW |
| 7 | 30/06/2018 | 18:34 | 132 kV Pare-Lekhi | Assam, AP | 80 MW |
| 8 | 15/06/2018 | 19:11 | 132 kV Pare-Lekhi | Assam, AP | 83 MW |
| 9 | 07/06/2018 | 18:34 | 132 kV Pare-Lekhi | Assam, AP | 81 MW |
| 10 | 06/06/2018 | 19:12 | 132 kV Pare-Lekhi | Assam, AP | 82 MW |

Agenda 6. Intimation of outages in State Power System by SLDCs on real time

Grid disturbance dated 16.01.19 in Meghalaya System

Agenda 7. Ensuring reliable power supply to Manipur system

- **To ensure reliable power supply to Manipur System, the following three steps can be taken:**
 - **132 kV Jiribam – Jiribam (MA) – Rengpang – Loktak link to be kept in loop**
 - **Restoration of 132 kV Dimapur – Imphal line**
 - **Upgradation of 132 kV Kohima – Karong – Imphal (MSPCL) link**

Study Results for the above is Given in [Annexure Manipur](#)

Voltage Profile Issues

Agenda 8. Multiple outage of Reactors and ongoing shutdown of hydro units of RHEP , Doyang, Kopili, Kopili Stg 2, Loktak causing High Voltage Issue

| Utility | Location | Voltage Level | Name of Bus/Line | Capacity(MVAR) | Type | Remarks |
|-----------|------------|---------------|------------------|----------------|------|--|
| POWERGRID | BONGAIGAON | 400 kV | Bus Reactor V | 125 | BUS | CSD(since 17.01.2019) |
| POWERGRID | BONGAIGAON | 400 kV | New Siliguri I | 63 | LINE | Reactor is being replaced with spare reactor available at Bongaigaon. Work under progress.(since 04.07.2018) |
| POWERGRID | BONGAIGAON | 400 kV | Azara | 63 | LINE | From 10/10/18 due to broken lock pin of Y phase lead from 08:10 Hrs(since 10.11.2018) |
| MeECL | BYRNIHAT | 400 kV | Bus | 63 | BUS | since 09.12.14 |

Agenda 11. Restoration / Commissioning of Reactors – Status Review

Agenda 12. Tentative schedule for Reactive Power Capability testing of generating units

Protection issues

Agenda 13. Near miss incidents with multiple Tripping of 400 kV Silchar – Imphal I

- 400 kV Silchar-Imphal Ckt I Tripped multiple times on 24/01/19, 25/01/19, 27/01/19 & 29/01/19.
- The incidents happened after synchronisation of line at 400kV without thorough patrolling & ensuring adequate RoW.
- Even after the first time charging on 26/01/19 , the line tripped on 27/01/19 & 29/01/19.
- Both the trippings were “near miss” incidents for Manipur System
- Action plan from NERTS requested to avert future incidents
- Letter No NERLDC/SO-I/NERTS/2019/2571 is enclosed as [Annexure 13](#)

14. Simultaneous Tripping of 400 kV Bongaigaon – Byrnihat line and 400 kV Bongaigaon – Azara line on 29.01.19

- **List of simultaneous tripping of NETC lines during the past 2 years enclosed as [Annexure-14](#)**
- **Action plan from NETC is requested with root cause analysis to avert future incidents**

Black Start Restoration Procedure

- ❖ **Black start and resoration procedure for NER Region has been published and uploaded in NERLDC website (<http://nerldc.in>) on 31st January, 2019.**
- ❖ **All Constituents are requested to go through the procedure and participate with mock drills, so that successful and speedy restoration is possible when need arises.**

Agenda 15. Tentative schedule for BSRP Mock exercise in NER during the year 2019

Agenda 16. Tentative schedule for BSRP workshop in NER

19. Furnishing technical parameters of the transmission element by CTU / STU in the standard format required for network modelling while requesting permission for first time charging

- **Standard format has been prepared for furnishing of network modelling while requesting permission for first time charging.**
- **It is requested to submit these formats along with the other already approved formats.**
- **Format details are in [Annexure 19a](#) for Transmission Line, [Annexure 19b](#) for Reactor and [Annexure 19c](#) for ICT**

20. Strict compliance of CERC approved schedule for seeking permission & submission of required data formats enabling RLDC / NLDC to accord permission on time for first time charging of elements

- **It is requested to all the constituents to strictly comply with the CERC approved schedule as given in [Annexure 3b](#)**
- **Some of the non-compliances are shown in [Annexure 3c](#)**
- **Transmission Utilities are requested follow the approved procedure and to ensure the following points:**
 - **Submission of formats A1-A6 by Asset Owner with a request for charging of new element to NERLDC at least ten (10) days prior to the anticipated date of first test charging.**
 - **Submission of B1-B5 (format-III) by the asset owner at least three (3) days prior to the date of first time charging**

20. Strict compliance of CERC approved schedule for seeking permission & submission of required data formats enabling RLDC / NLDC to accord permission on time for first time charging of elements

➤ Some of the non-compliance:

| SI No | Name of Elements | Date of Application | Date of Likely Charging | Difference in days between application and charging |
|-------|---|---------------------|-------------------------|---|
| 1 | 400/220/33 kV, 315 MVA ICT# 2 at 400 kV Bongaigaon S/s, POWERGRID | 06.09.18 | 06.09.18 | 0 |
| 2 | 400 kV, 125 MVAR Bus Reactor at Bongaigaon S/s | 12.07.18 | 14.07.18 | 2 |
| 3 | 400/132 kV 315 MVA ICT 3 at Silchar S/s | 26.06.18 | 28.06.18 | 2 |
| 4 | 400 kV, 125 MVAR Bus Reactor at Silchar S/s | 17.12.18 | 17.12.18 | 0 |
| 5 | 245 kV, 31.5 MVAR Bus Reactor at Mokokchung S/s | 16.11.18 | 20.11.18 | 4 |
| 6 | 400 kV, 125 MVAR Bus Reactor 3 at Balipara S/s | 23.07.18 | 25.07.18 | 2 |
| 7 | 315 MVA, 400/132/33 kV ICT 1 at Imphal Substation | 08.01.19 | 10.01.19 | 2 |

21. Proposal for First Time Charging of elements of Intra State Transmission System

- **It is requested to comply with these two requirements for first time charging of Intra State Transmission Systems:-**
 - **Approval from NERLDC as per format and schedule for elements of 400 kV & above voltage level**
 - **Submission of undertaking in respect of Protection System and Telemetry & Communication for elements of 132 kV & above voltage level**

Agenda 22: Scada and communication

Telemetry Availability Status at NERLDC from Constituents (as on 05-02-2019)

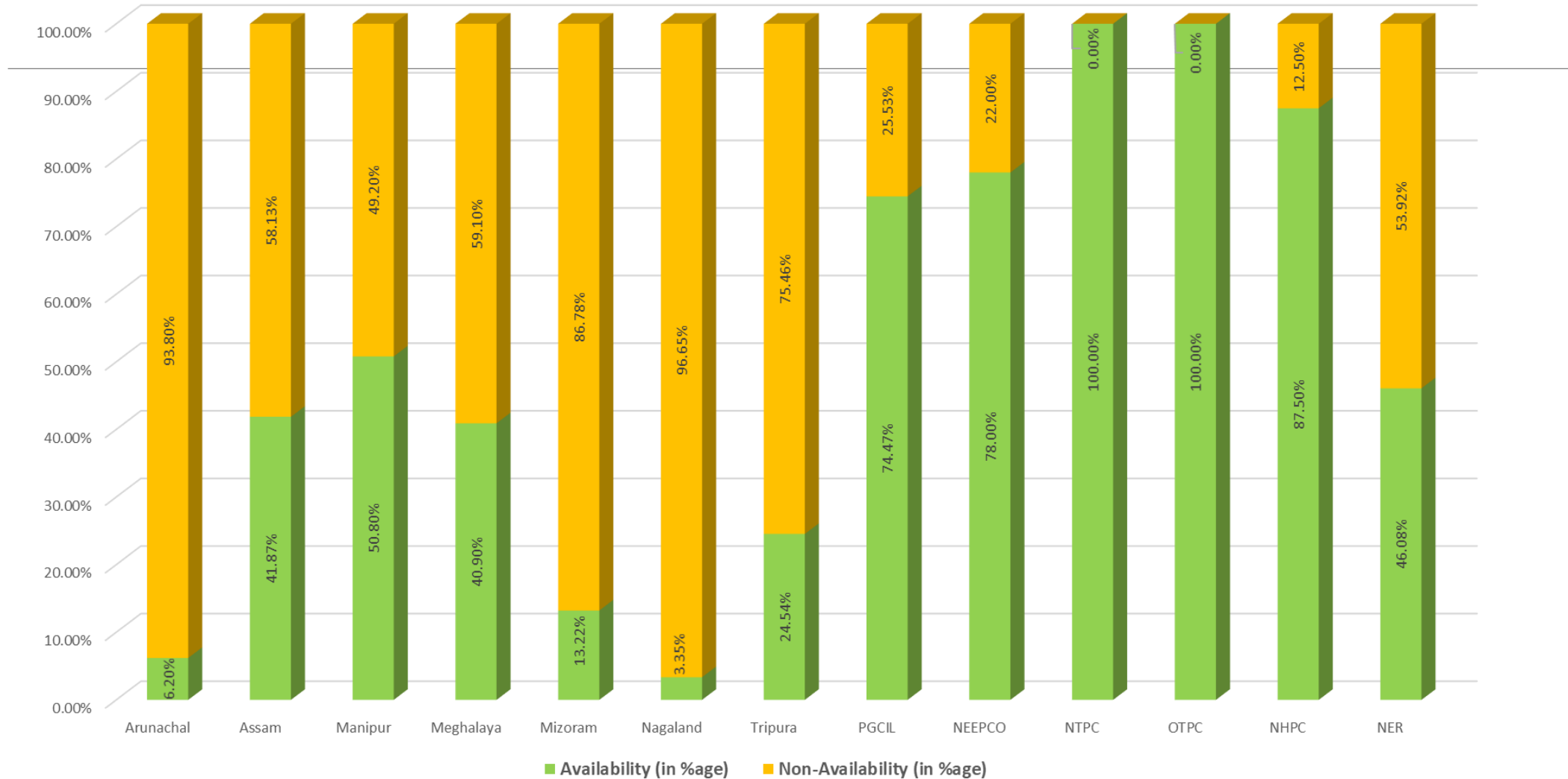

Comparison of Telemetry Availability Statistics

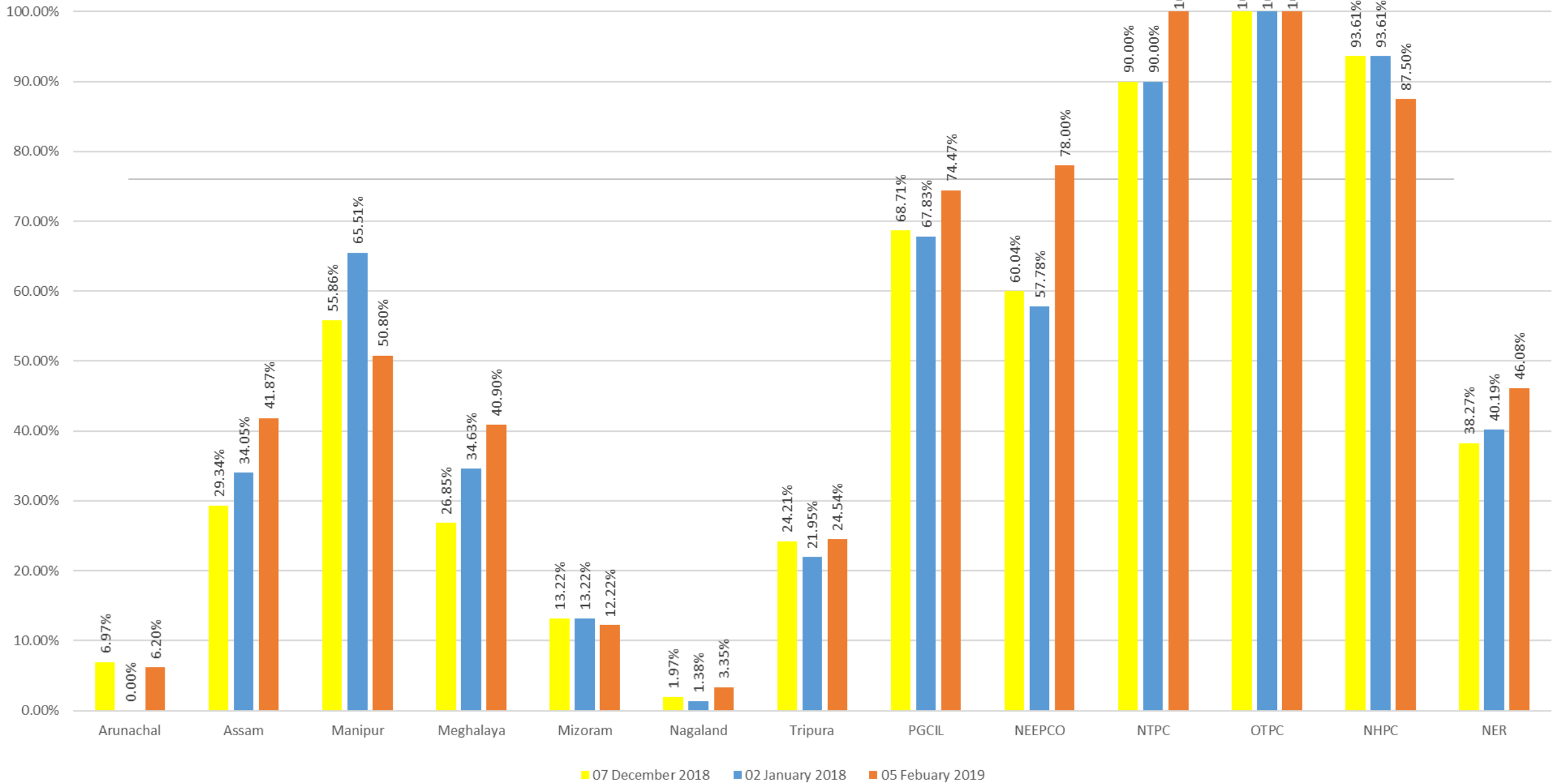

Agenda: Other Issues

28. Bus Configuration changes of Critical Nodes for reliable operation of NER Power System

- For reliable operation of NER Power System, some critical nodes are shown in [Annexure 28](#)
- Action: Date for Joint meeting of NERTS, NERPC & NERLDC is requested

29. Assessment of TTC, TRM & ATC by SLDC

- It is requested to all the SLDCs to assessment of TTC, TRM & ATC on respective Inter-State Transmission Corridor
- It is requested to submit the assessment by 20.02.19.
- The figures obtained by NERLDC is shown in the right

| State Wise TTC/Drawal Figures for 153rd OCCM | | | | |
|--|----------|------|------|------|
| States | Off Peak | | Peak | |
| | N-0 | N-1 | N-0 | N-1 |
| Arunachal | 254 | 224 | 254 | 224 |
| Assam | 1788 | 1638 | 1758 | 1608 |
| Manipur | 343 | 268 | 343 | 268 |
| Meghalaya | 270 | 200 | 249 | 153 |
| Mizoram | 132 | 120 | 132 | 120 |
| Nagaland | 204 | 189 | 204 | 189 |
| Tripura (including Bangladesh) | 278 | 88 | 299 | 131 |

30. Ratification of Technical and Commercial data for computation of PoC Charges and Losses for April to June'19 (Q1 of 2019-20)

- **All SLDCs have submitted except Arunachal Pradesh**
- **The data for ratification is in [Annexure 7](#)**

31. Accurate Load forecasting by SLDCs as per IEGC cl.5.3 for better system operation

- All the SLDCs are requested to improve the load forecast
- Letter from NERLDC on RMSE of load forecasting for the month of January 2019 enclosed as [Annexure-31](#)

| % Error with Actual Data (Forecasted by States) | | | | | | | |
|---|-------------------|-------|---------|-----------|---------|----------|---------|
| | Arunachal Pradesh | Assam | Manipur | Meghalaya | Mizoram | Nagaland | Tripura |
| Median | 16 | 6 | 7 | 10 | 32 | 12 | 8 |

32. Charging of 400 kV Silchar (PG) – Melriat (PG) I (Future) Main Bay for completing GIS Dia of 420 kV, 125 MVAR Bus Reactor at 400/132 kV Silchar Substation

- **Approval from Standing Committee is to be taken by NERTS, POWERGRID regarding charging of 400 kV Silchar – Melriat D/C (GIS) along with associated bays**

33. Updating the List of Important Grid Elements of NER

- **As per inputs received from utilities, List of Important Grid Elements of NER is updated till 31st Dec'18**
- **All the Utilities are requested to update the excel file circulated vide email dated 06.02.19.**
- **34. Implementation of Security Constrained Economic Dispatch (SCED) of Inter-State Generating Stations Pan-India on pilot basis w.e.f 01.04.2019 – Presentation by NERLDC**

(Ref: <http://cercind.gov.in/2019/orders/02-SM-2019.pdf>.)

35. Primary Response Testing:

Thank You

पावर सिस्टम ऑपरेशन कारपोरेशन लिमिटेड
(भारत सरकार का उद्यम)
POWER SYSTEM OPERATION CORPORATION LIMITED
(A Government of India Enterprise)



उत्तर पूर्वी क्षेत्रीय भार प्रेषण केंद्र : लोअर नोंग्राह, लापालांग, शिलांग - 793 006, (मेघालय)
North Eastern Regional Load Despatch Centre : Lower Nongrah , Lapalang, Shillong - 793 006, (Meghalaya)
Ph : 0364 2537470, 2537427, fax - 2537486 Website : www.nerlhc.org, Email- nerlhc@posoco.in, CIN : U40105DL2009GOI188682

संदर्भ/Ref: NERLDC/RHEP/2019/2882

दिनांक/Date : 08-03-2019

To,
The General Manager (IC) (O&M),
NEEPCO
Brookland Compound
Lower New Colony
Shillong-793 003, Meghalaya.

विषय/SUB: Operation of RHEP units in Synchronous condenser mode

Sir,

This is to inform you that persistent high voltage is being observed at 400 kV Ranganadi bus and as per VDI report published by NERLDC, the voltage at 400 kV Ranganadi has been above IEGC voltage limit of 420 kV in 30.08 % of time in the month of February 2019. Apart from Ranganadi, High voltage situation is observed in almost all the 400 kV nodes in northern part of NER Grid in the off-peak hours.

In order to maintain voltage inside IEGC band, an average of 2-3 400 kV lines have to be kept in open condition in the off-peak hours on daily basis, which reduces reliability and security of the NER Grid. The operation of RHEP units in Synchronous Condenser mode shall help in controlling the voltage in Ranganadi bus in particular and northern part of NER Grid in general without compromising the security and reliability of the grid.

As per the agenda in sl. no. D 23 of the Minutes of 153rd OCC Meeting of NERPC, it was informed by NEEPCO to the forum that NEEPCO has written to BHEL(Bhopal) for solution. In view of the above mentioned concerns, you are requested to kindly look into the matter and expedite the process, so that the RHEP units can be operated in synchronous condenser mode to take care of the above mentioned concerns.

This is for your kind information and necessary action at your end please.

Yours sincerely,

(Handwritten signature)
08/03/2019
(वी. सुरेश / V Suresh)

Copy To:

1) सदस्य सचिव, उपक्षेत्रीय/
MS, NERPC

मुख्य महाप्रबंधक (प्रभारी) / Chief G.M. (IC)

उ.पू.क्षे.भा.प्रे.के/NERLDC

Tentative Procedure for Mock Black Start exercise at AGTCCPP & synch facility test at Kumarghat S/S

Sourav Mandal (सौरव मंडल)

Sent: 06 March 2019 14:13:31**To:** sldcitanagar@gmail.com; sldcaseb@gmail.com; sldcmanipur@gmail.com; sldcshg@gmail.com; sldc.ngl@gmail.com; tsecl_sldc@rediffmail.com; mzsldc@gmail.com; agbpb_cr@yahoo.com; agtpcr@gmail.com; dhep_doyang@rediffmail.com; khandong_cr@rediffmail.com; kopiliph@gmail.com; khandong_cr@rediffmail.com; loktakphop@gmail.com; parepowerstation@rediffmail.com; rhep.powerhouse@gmail.com; prasantakanungo@powergridindia.com; nerts_rtamc@powergridindia.com; h.talukdar@powergridindia.com; s.k.singh@powergridindia.com; nk.gupta@otpcindia.in; operationteam@otpcindia.in; ntpcbgtpp250@gmail.com; suranjan.sarkar@gmail.com; mrinalpaulnit@gmail.com
Cc: V Suresh (वी सुरेश); R Sutradhar (आर सुत्रधर); SYSTEM OPERATION NERLDC; brieflee.lyngkholi@gmail.com; pkmishra.y31@gmail.com; mukherjeesrijit2010@gmail.com; ms-nerpc@gov.in**Attachments:** Tentative Procedure for Mo~1.pdf (209 KB)

Madam/Sir,

In line with sl. no. D. 49 of Minutes of 153rd OCC Meeting, Mock Black Start Excercise at AGTCCPP is tentatively scheduled in March, 2019. The Tentative procedure for the said mock excercise is attched herewith for your valuable comments please. Kindly give your comments by 8th March, 2019 in order to finalize the procedure at the earliest.

Also, as mentioned in sl. no. D. 49 of Minutes of 153rd OCC Meeting, respective ISGSs are requested to finalize the dates for the mock exercise as per the tentative schedule.

Regards,

सौरव मंडल/ Sourav Mandal

उप प्रबंधक/ Deputy Manager (S.0-1),

उ.पु.क्षे.भा.प्रे.के., शिलांग/ NERLDC, Shillong

Tentative Procedure for mock black start exercise at AGTCCPP (NEEPCO) and synchronization facility testing at Kumarghat S/S (Powergrid)

R. C. Nagar (AGTCCPP) is a gas-based thermal generating station of NEEPCO having IC of 134 MW. It has (4 X 21) MW GTG and (2 X 25) MW STG. It is connected to the main grid through 132 kV D/C AGTCCPP – Agartala TLs, 132 kV AGTCCPP - Kumarghat TL.

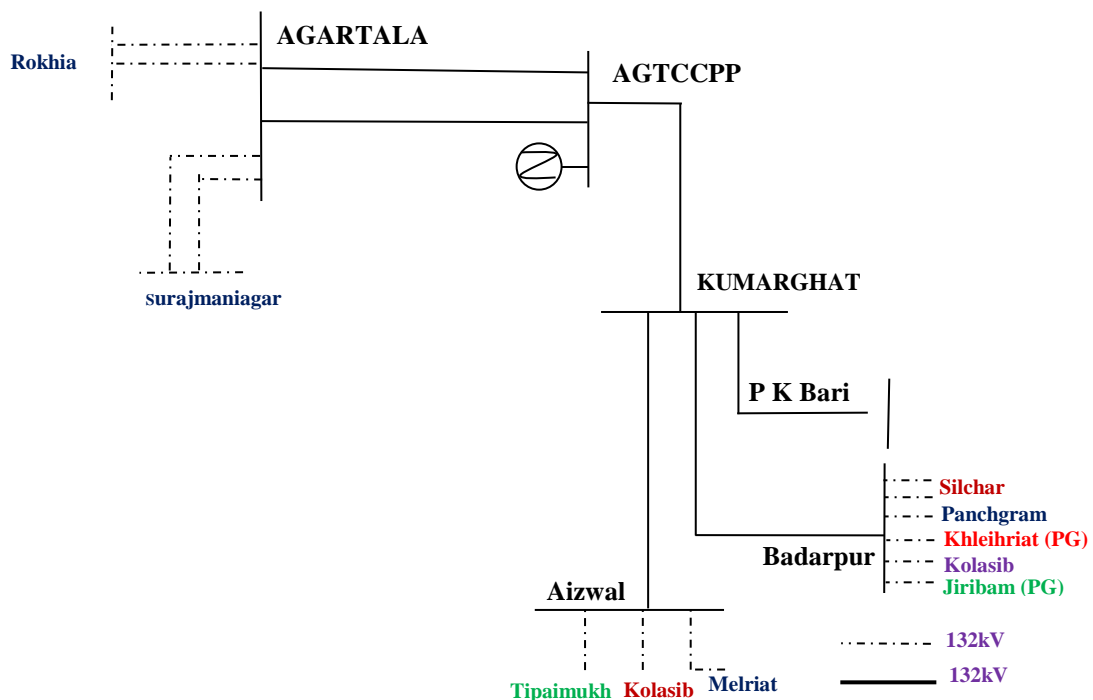

An exercise has been devised to do mock black start of Unit 1 at AGTCCPP, charging the 132kV AGTCCPP – Kumarghat line and synchronization of the same at Kumarghat S/S in order to supply the load of southern NER grid in an event of Grid Disturbance.

Pre-requisites

1. Unit 1 of AGTCCPP shall be shifted to Bus 1 from Bus 2 (as per present configuration given in Annex I)
2. 132kV AGTCCPP – Kumarghat line shall be shifted to Bus 1 from Bus 2 (as per present configuration given in Annex I)
3. 132kV AGTCCPP – Agartala line II shall be shifted to Bus 2 from Bus 1 (as per present configuration given in Annex I)
4. SPS – 9 to be kept in OFF condition at AGTCCPP.

Procedure

Preparation

1. AGTCCPP Unit 1 breaker to be opened.
2. Schedule generation of AGTCCPP to be maintained with all remaining generating units available.
3. Both end breakers of 132 kV AGTCCPP - Kumarghat to be opened.
4. Bus Coupler breaker at 132 kV AGTCCPP S/S to be tripped. The 132kV AGTCCPP Bus 1 is dead.

Mock Black Start

5. Black Start AGTCCPP Unit 1 using 500 kVA DG and charge the 132kV AGTCCPP Bus 1.
6. 132kV AGTCCPP – Kumarghat line shall be charged from AGTCCPP and line shall be synchronized at Kumarghat with Grid frequency.
7. Bus Coupler breaker at 132 kV AGTCCPP S/S to be closed.
8. Schedule generation of AGTCCPP to be maintained.

The Second Phase of the exercise shall be to black start an unit at AGTCCPP and extend start-up power to OTPC Palatana, via. 132 kV AGTCCPP – Agartala line 1 (say), 132 kV Agartala – Surajmaninagar 1 (say) & 132 kV Surajmaninagar – Palatana.

19-Feb-2019 15:28:46

AGART_NO
AGARTALTA

| | |
|-----------------------|--------------------|
| STN. TOTAL LOAD | 1.0MW 0.2MVAR |
| STN. TOTAL GENERATION | 86.1MW 15.7MVAR |

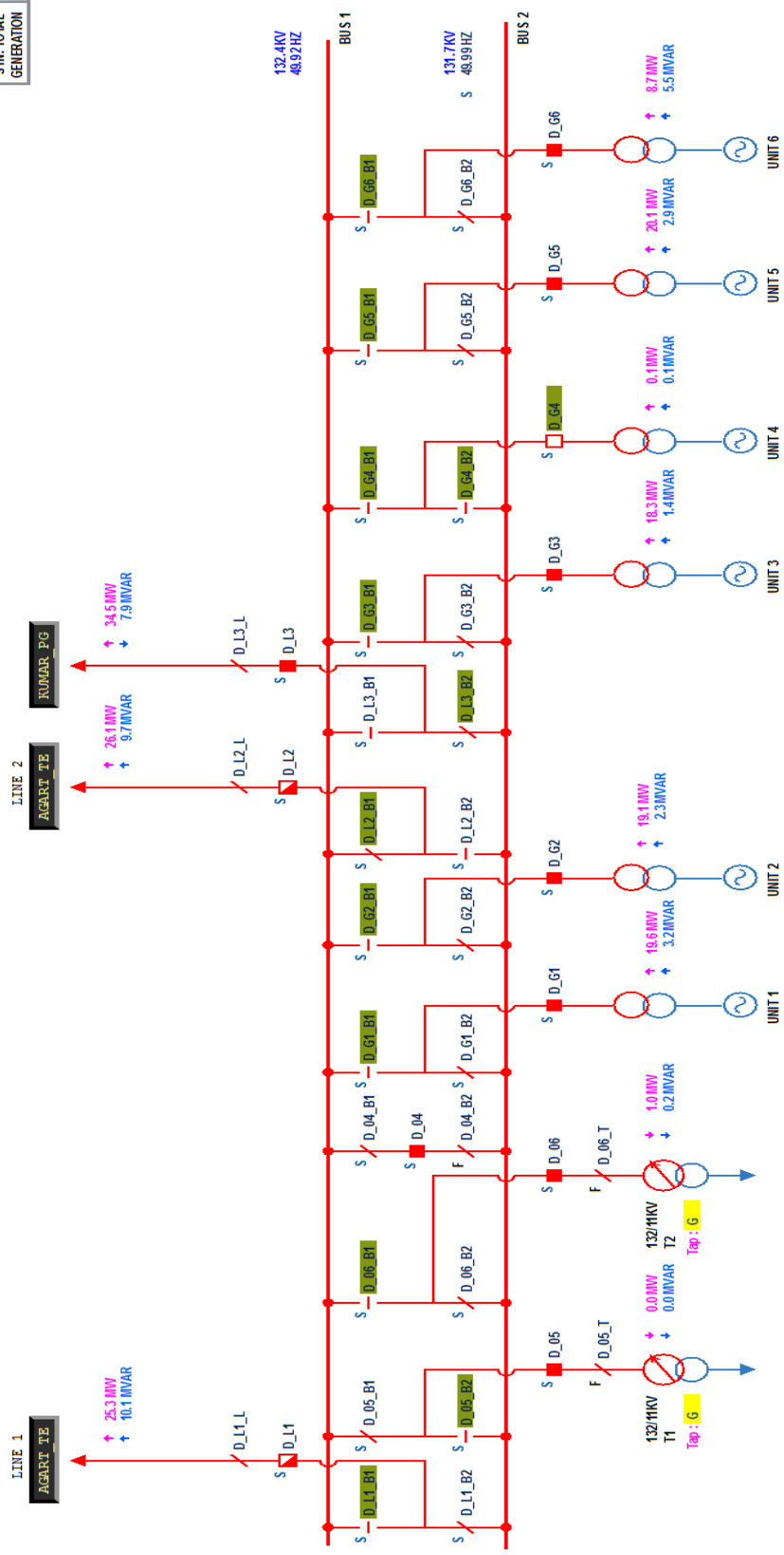

पावर सिस्टम ऑपरेशन करपोरेशन लिमिटेड
(भारत सरकार का उद्यम)
POWER SYSTEM OPERATION CORPORATION LIMITED
(A Government of India Enterprise)



उत्तर पूर्वी क्षेत्रीय भार प्रेषण केंद्र : लोअर नंगरा, लापालांग, शिलांग-793006, (मेघालय)
North Eastern Regional Load Despatch Centre: Lower Nongrah, Lapalang, Shillong - 793006, (Meghalaya)
Ph : 0364-2537470, 2537427, Fax - 2537486 Website : www.nerldc.org, Email - nerldc@posoco.in, CIN : U40105DL2009GOI188682

संदर्भ : उपक्षेत्रीय/एस.ओ-II/ 2798
Ref : NERLDC/SOII/ 2798

दिनांक/Date: 22.02.19

सेवा में/To: General Manager
AGTCCPP (NEEPCO)
Laxmipur, Tripura - 799210

प्रतिलिपि/Copy to: General Manager (I/C) (O&M),
NEEPCO Ltd, Brookland Compound,
Lower New Colony, Shillong - 793003.

विषय/Sub: Low Frequency Oscillations at Agartala PMU

महोदय,

It is for your kind information that low frequency oscillations in Voltage have been observed at Agartala PMU on 21st Feb 2019. Similar oscillations have been observed earlier and same had been communicated as well.

Low frequency oscillations of about 0.3 Hz were observed in the voltage of Agartala PMU on 21st Feb 2019. Such kind of oscillations, if undamped, pose a threat to system stability and this can result in large scale disturbances. The units of AGTCCPP were identified in earlier cases as the source of these oscillations. Also it was decided to install DAVR to mitigate the issue of such oscillations.

It is requested to intimate which machines are causing the oscillations.

Also, it is requested to mention whether new DAVR have been installed in all the units of AGTCCPP by 26.02.19.

धन्यवाद एवं सादर सहित।

अमरेश 22.02.19

भवदीय /Yours Sincerely

अ.मल्लिक / A. Mallick)

व. महाप्रबंधक (एस.ओ-2) Sr.G.M. (S.O.-II)

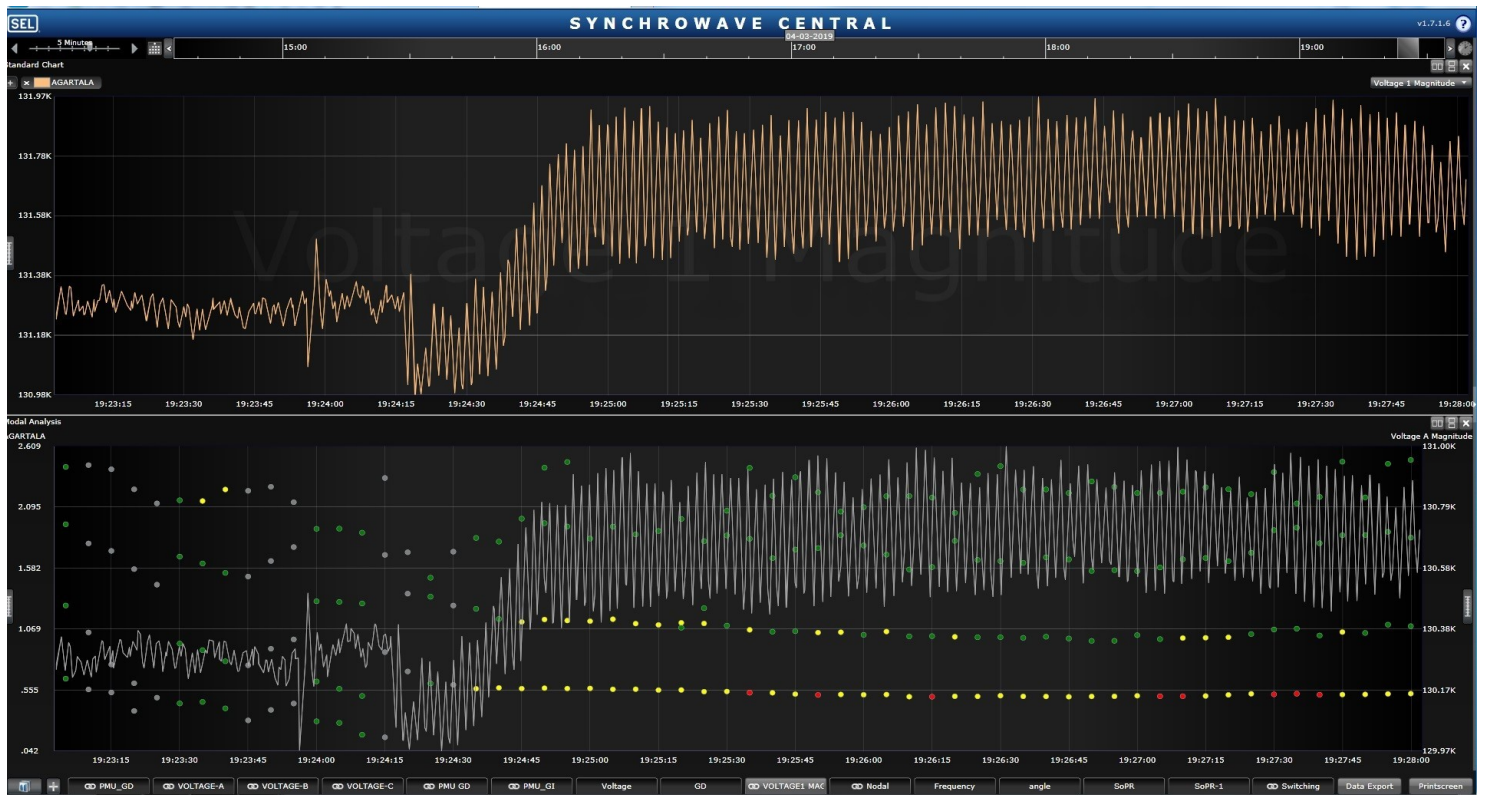

STATUS OF DATA VALIDATION OF NERTS STATIONS AS PER 12TH NeTEST MEETING

| Sl. No. | Name of RTU | Status of Data validation | Date of Validation |
|---------|-------------------|--|--------------------|
| 1 | Aizawl | Joint Verification done; Missing Address to be implemented in Site | 21-02-2019 |
| 2 | Badarpur | Joint Verification done; Missing Address to be implemented in Site | 25-02-2019 |
| 3 | Balipara | Joint Verification done; Missing Address to be implemented in Site | 08-01-2019 |
| 4 | BNCHVDC | Not done | NA |
| 5 | Bongaigoan | Joint Verification done; Missing Address to be implemented in Site | 09-02-2019 |
| 6 | Dimapur | Joint Verification done; Missing Address to be implemented in Site | 28-02-2019 |
| 7 | Haflong | Joint Verification done; Missing Address to be implemented in Site | 26-02-2019 |
| 8 | Imphal | Completed | 28-02-2019 |
| 9 | Itanagar(Nirjuli) | Joint Verification done; Missing Address to be implemented in Site | 25-02-2019 |
| 10 | Jiribam | Joint Verification done; Missing Address to be implemented in Site | 26-02-2019 |
| 11 | Khleiriat | Joint Verification done; Missing Address to be implemented in Site | 27-02-2019 |
| 12 | Kopili-Ex | Not done | NA |
| 13 | Kumarghat | Joint Verification done; Missing Address to be implemented in Site | 27-02-2019 |
| 14 | Mariani | Joint Verification done; Missing Address to be implemented in Site | 28-02-2019 |
| 15 | Melriat | Completed | 26-02-2019 |
| 16 | Misa | Joint Verification done; Missing Address to be implemented in Site | 08-01-2019 |
| 17 | Mokokchung | Joint Verification done; Missing Address to be implemented in Site | 28-02-2019 |
| 18 | Namsai | Not done | NA |
| 19 | Roing | Not done | NA |
| 20 | Salakati | Not done | NA |
| 21 | Silchar | Not done | NA |
| 22 | Tezu | Not done | NA |
| 23 | Ziro | Completed | 27-02-2019 |

Annexure 3 (a):

Underdrawal of States and Over Injection of ISGS during High Frequency:

| Date | Frequency Violation no. | Regional Entity | Frequency (Hz) | Drawal Schedule (MW) | Actual Schedule (MW) | Actual Deviation (MW) |
|----------|-------------------------|-----------------|----------------|----------------------|----------------------|-----------------------|
| 24-02-19 | 6729 | MEGHALAYA | 50.16 | 232 | 220 | -12 |
| | | TRIPURA | | 106 | 43 | -63 |
| | | MIZORAM | | 61 | 54 | -7 |
| 24-02-19 | 6727 | AP | 50.18 | 100 | 89 | -11 |
| | | NAGALAND | | 97 | 90 | -7 |
| 17-02-19 | 6715 | AP | 50.17 | 101 | 86 | -15 |
| | | ASSAM | | 610 | 579 | -31 |
| | | TRIPURA | | 54 | 28 | -26 |
| | | MANIPUR | | 79 | 70 | -9 |
| | | MIZORAM | | 53 | 38 | -15 |
| | | NAGALAND | | 63 | 53 | -10 |
| 15-02-19 | 6708 | TRIPURA | 50.10 | 58 | 30 | -28 |
| | | MANIPUR | | 91 | 81 | -10 |
| | | MIZORAM | | 66 | 56 | -10 |
| 15-02-19 | 6707 | AP | 50.20 | 90 | 78 | -12 |
| | | MEGHALAYA | | 191 | 175 | -16 |
| | | TRIPURA | | 49 | 39 | -11 |
| | | MANIPUR | | 85 | 79 | -6 |
| | | MIZORAM | | 65 | 55 | -10 |
| | | NAGALAND | | 77 | 69 | -8 |
| 11-02-19 | 6698 | BgTPP | 50.22 | 250 | 285 | 35 |
| 11-02-19 | 50.22 | ASSAM | 50.22 | 608 | 556 | -52 |
| | | MEGHALAYA | | 221 | 208 | -13 |
| 10-02-19 | 6692 | TRIPURA | 50.08 | 46 | 25 | -21 |
| | | AP | | 96 | 65 | -33 |
| | | MANIPUR | | 96 | 79 | -17 |
| | | MIZORAM | | 38 | 36 | -2 |
| | | NAGALAND | | 57 | 50 | -7 |
| 09-02-19 | 6690 | BgTPP | 50.18 | 250 | 285 | 35 |
| | | AP | | 88 | 82 | -6 |
| | | MEGHALAYA | | 221 | 211 | -10 |
| | | MANIPUR | | 146 | 137 | -9 |
| | | MIZORAM | | 65 | 39 | -26 |
| 08-02-19 | 6689 | NAGALAND | 50.20 | 96 | 75 | -21 |
| | | MIZORAM | | 62 | 49 | -13 |
| 07-02-19 | 6687 | ASSAM | 50.11 | 790 | 742 | -48 |
| | | | | 78 | 55 | -23 |

पावर सिस्टम ऑपरेशन कारपोरेशन लिमिटेड
(भारत सरकार का उद्यम)
POWER SYSTEM OPERATION CORPORATION LIMITED
(A Government of India Enterprise)



उत्तर पूर्वी क्षेत्रीय भार प्रेषण केंद्र : लोअर नोंग्राह, लापालांग, शिलांग - 793 006, (मेघालय)
North Eastern Regional Load Despatch Centre : Lower Nongrah , Lapalang, Shillong - 793 006, (Meghalaya)
Ph : 0364 2537470, 2537427, fax - 2537486 Website : www.nerlhc.org, Email- nerlhc@posoco.in, CIN : U40105DL2009GOI188682

संदर्भ/Ref: NERLDC/SO-I/OTPC/2019/2846

दिनांक/Date : 07-03-2019

To,
The Head of the Project,
OTPC Power Plant
Udaipur-Kakraban Road, Palatana P.O.,
District Gomati, Tripura-799105

विषय/SUB: Multiple Emergency Shutdown availed by OTPC Palatana ISGS.

Sir,

This is to bring to your notice that OTPC Palatana has availed emergency shutdown of Module II since 23:28 hrs of 06-03-2019. Following points may kindly be noted regarding the said shutdown:

- It was informed that GT#2 Axial compressor efficiency degradation has happened more than 6% and OEM GE has recommended to immediately go for off-line compressor washing as a statutory requirement, failing which compressor surge can occur, damaging the compressor blades. From the above, it appears that the process of degradation has taken place over a period of time and hence, work mentioned is that of planned nature and Palatana could have planned the shutdown in 153rd OCC meeting.
- The request for emergency shutdown was received via email by NERLDC on 19:51 Hrs of 05/03/19. OTPC Palatana had given day-ahead DC w.r.t. only one module for 07/03/19, before receiving approval for the said shutdown, which is not a right practice.
- Also, in last two months, OTPC Palatana has availed emergency shutdown of Module I twice for works which could have been planned in advance and availed as planned shutdown in OCC. Details of the emergency shutdown are as follows:

| Sl. no. | Name of Unit | Outage | | Restoration | | Reasons |
|---------|----------------|-----------|-------|-------------|-------|---|
| 1 | Palatana GTG I | 06-Jan-19 | 23:26 | 09-Jan-19 | 18:41 | ESD for replacement of gas turbine inlet air filters. |
| 2 | Palatana STG I | 06-Jan-19 | 23:26 | 09-Jan-19 | 22:47 | ESD for replacement of gas turbine inlet air filters. |
| 3 | Palatana GTG I | 10-Feb-19 | 23:28 | 12-Feb-19 | 12:34 | ESD for replacement of gas turbine inlet air filters. |
| 4 | Palatana STG I | 10-Feb-19 | 23:27 | 12-Feb-19 | 16:13 | ESD for replacement of gas turbine inlet air filters. |

OTPC Palatana is requested to avail planned shutdown of the units after due discussion in OCC Meetings before the parameters reach emergency condition. Planned shutdown of the units shall help the NER constituent states in arrangement of power from elsewhere and maintain the Load-Generation balance of the region.

This is for your kind information and necessary action at your end please.

Yours sincerely,

04/3/2019

(आर. सूत्रधार /R. Sutradhar)

व. महाप्रबंधक (एस.ओ-1)/Sr. GM (S.O-1)

उ.पू.क्षे.भा.प्रे.के/NERLDC.

Copy To:

1) सदस्य सचिव, उपक्षेविस/ MS, NERPC

2) मुख्य महाप्रबंधक (उ.पू.क्षे.भा.प्रे.के)

/ CGM (NERLDC)

पावर सिस्टम ऑपरेशन कर्पोरेशन लिमिटेड
(भारत सरकार का उद्यम)
POWER SYSTEM OPERATION CORPORATION LIMITED
(A Government of India Enterprise)



उत्तर पूर्वी क्षेत्रीय भार प्रेषण केंद्र : लोअर नंगरा, लापालांग, शिलांग-793006, (मेघालय)
North Eastern Regional Load Despatch Centre: Lower Nongrah, Lapalang, Shillong - 793006, (Meghalaya)
Ph : 0364-2537470, 2537427, Fax - 2537486 Website : www.nerlhc.org, Email - nerlhc@posoco.in, CIN : U40105DL2009GOI188682

Ref: NERLDC/ GM /33/ 2878

Dt. 07.03.2019

To
The General Manager
KHEP, NEEPCO Ltd., Umrangso

Copy to:

1. The General Manager (I/C) (O&M), NEEPCO, Lower New Colony, Shillong-3
2. The Chief General Manager (I/C), NERTS, POWERGRID, Shillong-6
3. The Member Secretary, North Eastern Regional Power Committee, NERPC Complex, Shillong - 6
4. CGM (I/C), NERLDC, POSOCO, Shillong - 6

Sub : Lack of information w.r.t. tripping of 132 kV Kopili - Khandong-II on 06.03.19

Dear Sir(s),

This is to inform you that, the following misoperation has been observed at our end w.r.t. 132kV Kopili - Khandong - II transmission line on 06.03.19:

1. At around 1900 Hrs it had been observed by our Evening Shift personnel that there was no power flow through the 132kV Kopili - Khandong - line II implying that the line might be in open condition. However, no information was available with NERLDC regarding tripping/ outage of the same.
2. The matter communicated to both end substation shift-in-charges; but it was initially denied that the line was in open condition. Subsequently it was informed that the line was in idle charge condition from Khandong end.
3. Following which, since there was no information available with either end substations regarding any reasons for outage/ faulty condition; in view of overall optimum grid functioning, instruction/ code was issued by NERLDC for initially opening from Khandong end (since, as informed by them, no synchronizing facility is available at Kopili end) at 19:10 hrs; following which code for charging from Kopili end and synchronizing at Khandong end was issued by NERLDC at 19:13 hrs. However, while charging from Kopili end, the said line tripped and it was informed by Kopili that the reason of tripping was due to SOTF (Details as sought is still awaited).

Now, as per the CEA (Grid Standards) Regulations, 2010; discrepancy/ violation of Grid Standard has been observed w.r.t. the following clauses of the standard; which may please be noted:

1. As per Cl. No. 6(1), **Coordination in Operations:** Quote: No Entity shall introduce or take out the element of the grid without the concurrence of the Appropriate Load Despatch Centre except in case of imminent risk of safety of plant and personnel in which case it must intimate Appropriate Load Despatch Centre giving reasons therefore. Unquote
2. Further, as per Cl. No. 12(1), **Reporting of events affecting grid operation:** Quote: (1) Any tripping of generating unit or transmission element, along with relay indications, shall be promptly reported by the respective Entity to the Appropriate Load Despatch Centre in the reporting formats as devised by the Appropriate Load Despatch Centre.

Therefore, in view of safety and security of the interconnected Grid and co-ordinated operation, it is hereby requested immediate follow-up may please be carried out w.r.t. the said discrepancy and such event shall be avoided in future.

This is for your kind information and further necessary action please.

Thanking you.

Yours faithfully



07/3/2019
(राजिब सूत्रधर)

वरिष्ठ महाप्रबंधक (एस.ओ-1)

उ.पू.क्षे.भा.प्रे.के, शिलांग

Study for Connection of 132 kV Itanagar – Lekhi (Naharlagun) S/C

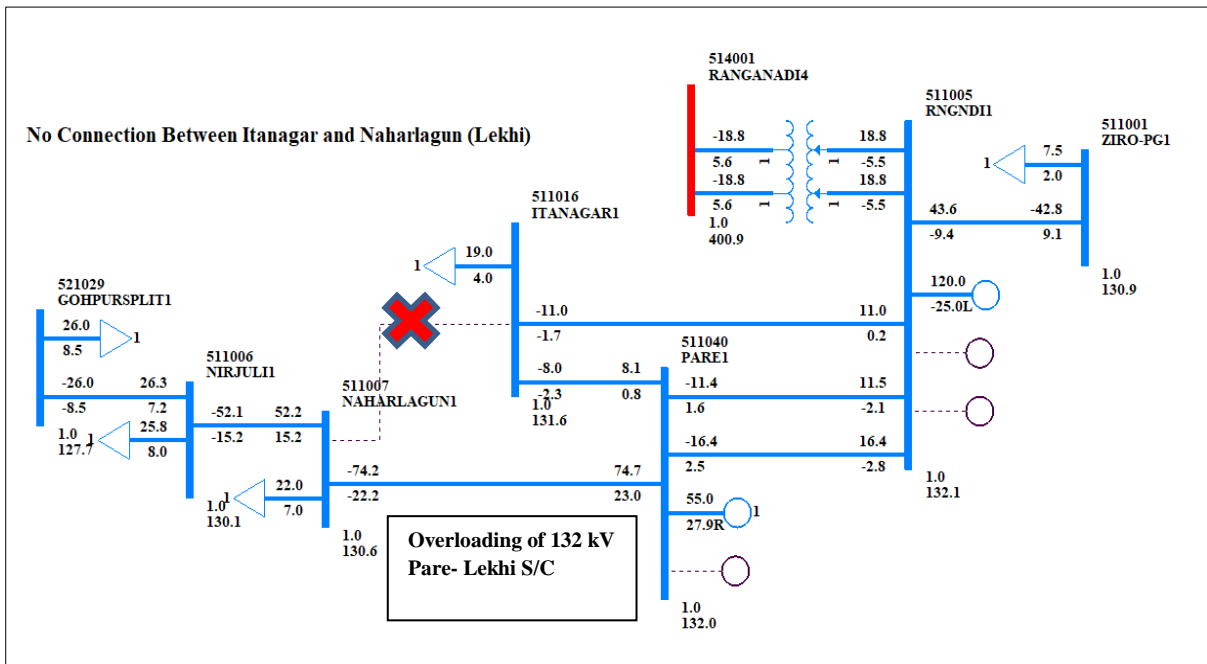
132 kV Itanagar – Lekhi (Naharlagun) S/C is kept open which leads to overloading of 132 kV Pare- Lekhi S/C under various conditions.



Connecting 132 kV Itanagar – Lekhi (Naharlagun) S/C leads to decrease in loading of 132 kV Pare – Lekhi by about 11 MW, the same power being transferred from 132 kV Itanagar to 132 kV Lekhi.

Also, in case of tripping of 132 kV Pare – Lekhi S/C, 132 kV Itanagar – Lekhi will act as an alternate path for power supply to Lekhi Area of AP Power system, thereby increasing the reliability of the grid.

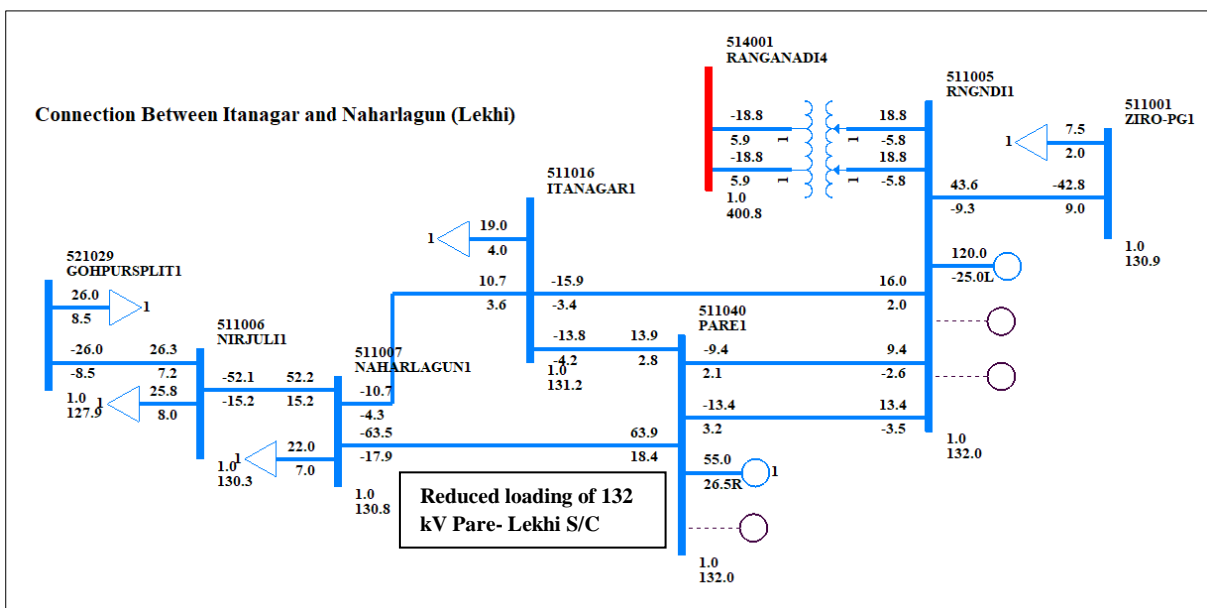

It is therefore desired to kept the link 132 kV Itanagar – Lekhi (Naharlagun) closed in all conditions

List of Dias in North Eastern Regional Grid

| Sl. No. | Name of Substation | Name of Dia | Issues | Possible Solution |
|---|----------------------------------|--|---|-------------------|
| 1 | 400/220/33 kV Azara | Silchar I and 80 MVAR Bus Reactor | When both Buses of Azara trip, power flow in Azara - Silchar I and ICT I is zero | |
| | | Bongaigaon I and 400/220/33 kV 315 MVA ICT-2 | | |
| | | 400/220/33 kV 315 MVA ICT-1 connected to 400 kV Bus 1 & Bus-2 | | |
| 2 | 400/220/33 kV Balipara | Bongaigaon I & Biswanath Chariali III | When both 400 kV Buses of Balipara trip, power flow in both the ICT I and II is zero. Also, there is no connectivity between Bongaigaon and Misa. | |
| | | Bongaigaon II & Biswanath Chariali IV | | |
| | | Biswanath Chariali I & Misa I | | |
| | | Biswanath Chariali II & Misa II | | |
| | | 315 MVA ICT I & 50 MVAR Bus Reactor | | |
| | | 315 MVA ICT II & 80 MVAR Bus Reactor | | |
| | | Bongaigaon III & Kameng I (future) | | |
| Bongaigaon IV & Kameng I (Future) | | | | |
| 3 | 400 kV BgTPP | 125 MVA Bus Reactor connected to 400 kV Bus | | |
| | | All elements are connected via Double Main and and Transfer Scheme | | |
| 4 | 400/132/33 kV Biswanath Chariali | 400/132 kV 200MVA ICT 1 and 400/132 kV 200 MVA ICT 2 | When both the buses of Biswanath Chariali trip, power flow in Ranganadi I and Balipara 4 is zero | |
| | | Lower Subansiri 1 and Lower Subansiri 2 | | |
| | | Lower Subansiri 3 and Lower Subansiri 4 | | |
| | | Filter Bank 3 connected to both Buses via Double Bus Scheme | | |
| | | 800 kV Converter Pole 1 connected to both Buses via Double Bus Scheme | | |
| | | 800 kV Converter Pole 2 connected to both Buses via Double Bus Scheme | | |
| | | Filter Bank 1 and Filter Bank 2 | | |
| | | Ranganadi 1 and Bus Reactor 1 | | |
| | | Ranganadi 2 and Balipara 2 | | |
| Balipara 1 and Balipara 3 | | | | |
| 5 | 400/220/33 kV Bongaigaon | Balipara 4 and 80 MVAR Bus Reactor II | When both buses of Bongaigaon trip, power flow in New Siliguri II, Balipara II, BTPS II and ICT II is zero as all these elements share dias with Bus Reactors | |
| | | New Siliguri I & 315 MVA ICT I | | |
| | | New Siliguri II & 50 MVAR Bus Reactor I | | |
| | | Balipara II & 50 MVAR Bus Reactor II | | |
| | | Balipara I & Alipurduar I | | |
| | | Balipara IV & Alipurduar II | | |
| | | Balipara III & Azara | | |
| | | BTPS I & Byrnihat | | |
| BTPS II & 2x 80 MVAR Bus Reactor III and IV | | | | |
| 125 MVAR Bus Reactor V and 315 MVA ICT II | | | | |
| 6 | 400/220/132 kV Byrnihat | All elements are connected via Double Main Cum Transfer Scheme | | |
| 7 | 400/220/33 kV Misa | 50 MVAR Bus Reactor (individual switchable) & Balipara I (Now both elements directly connected to both bus(s)) | When both buses of Misa Trip, power flow in ICT II and Balipara I is zero | |
| | | Balipara II & 315 MVA ICT I | | |
| | | 315 MVA ICT II directly connected to both bus | | |
| 8 | 400/132 kV Palatana | STG I & 125 MVA ICT I | | |
| | | GTG I & Silchar I | | |
| | | STG II & Silchar II | | |
| | | GTG II & 125 MVA ICT II | | |
| | | 80 MVAR Bus Reactor connected to both the Buses | | |
| 9 | 400 kV Ranganadi | 360 MVA ICT I (directly connected to 400 kV Bus) | All elements are connected to 400 kV Bus B via Double Bus Scheme (Bus-A is not in service) | |
| | | 360 MVA ICT II (directly connected to 400 kV Bus) | | |
| | | Balipara I (directly connected to 400 kV Bus) | | |
| | | Balipara II (directly connected to 400 kV Bus) | | |
| 10 | 400/132/33 kV Silchar | Palatana II & 200 MVA ICT II | When both buses of Silchar trip, power flow in Palatana I and Byrnihat line is zero as both the lines share dia with Bus Reactor | |
| | | Palatana I & 63 MVAR Bus Reactor II | | |
| | | Azara & 200 MVA ICT I | | |
| | | Byrnihat & 63 MVAR Bus Reactor I | | |
| | | ICT III (connected to both the 400 kV Buses) | | |
| | | 125 MVAR Bus Reactor (connectd to both the 400 kV Buses) | | |
| | | Imphal I and P K Bari I (Future) | | |
| Imphal II and P K Bari II (Future) | | | | |

Red color indicates problem
 Green color indicates no problem

Tripping details of 132Kv Imphal (PG) – Imphal (MA):

| Sl. no. | Element Name | Outage Date | Outage Time | Revival Date | Revival Time | Reason End 1 | Reason End 1 |
|---------|-------------------------------------|-------------|-------------|--------------|--------------|---|-------------------------------------|
| 1. | Imphal (Manipur) - Imphal (PG) – II | 26-Jan-19 | 05:37:00 | 26-Jan-19 | 06:08:00 | Tripping is in Yurembam end only due to fault in 132/33 kV Transformer-I at Kongba SS | No Tripping |
| 2. | Imphal (Manipur) - Imphal (PG) – I | 26-Jan-19 | 05:37:00 | 26-Jan-19 | 06:08:00 | Tripping is in Yurembam end only due to fault in 132/33 kV Transformer-I at Kongba SS | No Tripping |
| 3. | Imphal (Manipur) - Imphal (PG) – I | 29-Jan-19 | 17:43:00 | 29-Jan-19 | 17:51:00 | No tripping | Over current |
| 4. | Imphal (Manipur) - Imphal (PG) – II | 29-Jan-19 | 17:43:00 | 29-Jan-19 | 17:52:00 | No Tripping | Over current |
| 5. | Imphal (Manipur) - Imphal (PG) – II | 08-Feb-19 | 18:25:00 | 08-Feb-19 | 18:58:00 | Details awaited | No Tripping |
| 6. | Imphal (Manipur) - Imphal (PG) – I | 08-Feb-19 | 18:25:00 | 08-Feb-19 | 19:36:00 | Details awaited | No Tripping |
| 7. | Imphal (Manipur) - Imphal (PG) - I | 19-Feb-19 | 13:45:00 | 19-Feb-19 | 14:02:00 | No trip | fault at 33 kV end, Details awaited |
| 8. | Imphal (Manipur) - Imphal (PG) - I | 19-Feb-19 | 13:45:00 | 19-Feb-19 | 13:51:00 | fault at 33 kV side , Details awaited | No trip |
| 9. | Imphal (Manipur) - Imphal (PG) - I | 23-Feb-19 | 19:39:00 | 23-Feb-19 | 20:02:00 | Details awaited | No tripping |
| 10. | Imphal (Manipur) - Imphal (PG) - I | 23-Feb-19 | 19:39:00 | 23-Feb-19 | 20:02:00 | Details awaited | No tripping |

पावर सिस्टम ऑपरेशन करपोरेशन लिमिटेड
(भारत सरकार का उद्यम)
POWER SYSTEM OPERATION CORPORATION LIMITED
(A Government of India Enterprise)



उत्तर पूर्वी क्षेत्रीय भार प्रेषण केंद्र : लोअर नंगरा, लापालांग, शिलांग-793006, (मेघालय)
North Eastern Regional Load Despatch Centre: Lower Nongrah, Lapalang, Shillong - 793006, (Meghalaya)
Ph : 0364-2537470, 2537427, Fax - 2537486 Website : www.nerldc.org, Email - nerldc@posoco.in, CIN : U40105DL2009GOI188682

संदर्भ : उपक्षेत्रीय/एस.ओ-11/ 2539
Ref : NERLDC/SOII/2539

दिनांक/Date: 30.01.19

सेवा में/To:

1. General Manager, SLDC, MSPCL, Imphal, Manipur – 795001
2. General Manager, Substation Circle, MSPCL, Imphal, Manipur – 795001

प्रतिलिपि/Copy to:

1. Member Secretary, NERPC, Shillong- 793006

विषय/Sub: Detailed Analysis & Furnishing Event information for disturbance in Capital & Ningthoukhong areas of Manipur Power System.

महोदया / महोदय,

As you are aware that disturbance of Category GD-1 occurred in Capital area of Manipur Power System at 05:37 Hrs on 26.01.19 and at 17:43 Hrs on 29.01.19 due to tripping of 132 Imphal (MSPCL) – Imphal (PG) D/C only at 132 Imphal (MSPCL).

Disturbance of Category GD-1 occurred in Ningthoukhong area of Manipur Power System 07:13 Hrs on 26.12.18 and at 14:06 Hrs on 27.01.19 due to tripping of 132 Loktak – Ningthoukhong line only at 132 kV Ningthoukhong.

You are requested to find out the root cause of the events and take appropriate action to resolve the issue at the earliest. It is also requested to intimate the root cause and action(s) taken at your end.

For analysis purpose, it is requested to upload Disturbance Recorder (DR), Event Logger (EL) outputs of 132 kV Imphal (MSPCL) and 132 kV Ningthoukhong for the events mentioned above along with a First Information Report (FIR) in Tripping Monitoring Portal (<http://103.7.131.234/Trippingnew/Account/Login.aspx>).

धन्यवाद एवं सादर सहित

भवदीय / Yours sincerely,

अमरेश 30.01.19

(अ.मल्लिक / A. Mallick)

व. महाप्रबंधक (एस.ओ-2) Sr. G.M. (S.O.-II)

पावर सिस्टम ऑपरेशन करपोरेशन लिमिटेड
(भारत सरकार का उद्यम)
POWER SYSTEM OPERATION CORPORATION LIMITED
(A Government of India Enterprise)



उत्तर पूर्वी क्षेत्रीय भार प्रेषण केंद्र : लोअर नंगरा, लापालांग, शिलांग-793006, (मेघालय)
North Eastern Regional Load Despatch Centre: Lower Nongrah, Lapalang, Shillong - 793006, (Meghalaya)
Ph : 0364-2537470, 2537427, Fax - 2537486 Website : www.nerldc.org, Email - nerldc@posoco.in, CIN : U40105DL2009GOI188682

संदर्भ : उपक्षेत्रीय/एस.ओ-II/ 2818
Ref : NERLDC/SOII/ 2818

दिनांक/Date: 28.02.19

सेवा में/To:

1. General Manager, SLDC, MSPCL, Imphal, Manipur – 795001
2. General Manager, Substation Circle, MSPCL, Imphal, Manipur – 795001

प्रतिलिपि/Copy to:

1. Member Secretary, NERPC, Shillong- 793006

विषय/Sub: Detailed Analysis & Furnishing Event information for disturbance in Capital area of Manipur Power System.

Ref: Letter No NERLDC/SO-II/2539

महोदया / महोदय,

Please refer the letter no NERLDC/SO-II/2539 dated 30.01.19. We have not received any reply from your end.

As you are aware that 3 nos. of disturbance of Category GD-1 in the month of Feb'19 and 2 nos. of disturbance of Category GD-1 in the month of Jan'19 occurred in Capital area of Manipur Power System due to tripping of 132 Imphal (MSPCL) – Imphal (PG) D/C only at 132 Imphal (MSPCL). Details received from site are as follows:

1. At 18:25 Hrs on 8th Feb'19 – Suspected downstream fault
2. At 13:45 Hrs on 19th Feb'19 – Fault in 33 kV side
3. At 19:39 Hrs on 23rd Feb'19 – Suspected downstream fault

You are requested to find out the root cause of the events and take appropriate action to resolve the issue at the earliest. It is also requested to intimate the root cause and action(s) taken at your end & the schedule for the maintenance activities to reduce the downstream faults due to cable faults, CT blast etc.

For analysis purpose, it is requested to upload Disturbance Recorder (DR), Event Logger (EL) outputs of 132 kV Imphal (MSPCL) for the events mentioned above & events mentioned in the previous letter along with a First Information Report (FIR) in Tripping Monitoring Portal (<http://103.7.131.234/Trippingnew/Account/Login.aspx>).

धन्यवाद एवं सादर सहित

भवदीय / Yours sincerely,

अमरेश 28.02.19
(अ.मल्लिक / A. Mallick)

व. महाप्रबंधक (एस.ओ-2) Sr. G.M. (S.O.-II)

Telemetry Availability Status at NERLDC from Constituents (as on 07-03-**2019): To Be Presented in 154th OCC Meeting**

| Sl. No. | Name of the Constituents | Total Analogue Data points | Total Digital Data points | Total Data Points | Analogue Data points Reporting | Digital Data Points Reporting | Total Reporting | Total %age of data Availability | Remarks |
|---------|--------------------------|----------------------------|---------------------------|-------------------|--------------------------------|-------------------------------|-----------------|---------------------------------|---|
| 1 | Arunachal Pradesh | 106 | 152 | 258 | 7 | 9 | 16 | 6.20% | 01 nos. of RTU reporting partially out of 09 nos. SIMs have been provided by DOP,AP |
| 2 | Assam | 1337 | 1954 | 3291 | 581 | 785 | 1339 | 40.67% | 38 nos. of RTU reporting partially out of 67 nos. Refer Annexure A and B |
| 3 | Manipur | 180 | 255 | 435 | 94 | 169 | 263 | 60.46% | 08 nos. of RTU reporting partially out of 11 nos. SIMs as provided has been commissioned. Nodes are reporting |
| 4 | Meghalaya | 409 | 388 | 797 | 237 | 92 | 329 | 41.28% | 17 nos. of RTU reporting partially out of 23 nos. |
| 5 | Mizoram | 71 | 50 | 121 | 9 | 7 | 16 | 13.22% | 01 nos. of RTU reporting partially out of 05 nos. Mizoram is yet to provide the SIMs. |
| 6 | Nagaland | 237 | 270 | 507 | 12 | 17 | 29 | 5.72% | 02 nos. of RTU reporting partially out of 17 nos. SIMs provided by DOP, Nagaland |
| 7 | Tripura | 524 | 715 | 1239 | 101 | 116 | 217 | 17.51% | 07 nos. of RTU reporting partially out of 23 nos. Only one SIM is provided by TSECL. - TSECL to provide remaining |
| 8 | PGCIL | 616 | 1111 | 1727 | 444 | 880 | 1324 | 76.66% | 20 nos. of RTU reporting partially out of 23 nos. |
| 9 | NEEPCO | 205 | 295 | 500 | 168 | 247 | 415 | 83% | Doyang RTU is not reporting consistently |
| 10 | NTPC | 28 | 51 | 79 | 28 | 51 | 79 | 100% | No issues |
| 11 | OTPC | 41 | 78 | 119 | 41 | 78 | 119 | 100% | No issues |
| 12 | NHPC | 20 | 36 | 56 | 17 | 30 | 47 | 83.93% | Data of station transformer are not reporting |
| | NER | 3754 | 5319 | 9073 | 1722 | 2424 | 4146 | 45.70% | |

ANNEXURE

| PHASE I APPROACH TO SOLVE THE TELEMETRY OF ASSAM | | | | |
|--|-------------------|---------------------|-------------|------------------------------|
| Sl. No. | Substation | Status | Target | Issue |
| 1 | Agia | Partially Reporting | March-19 | |
| 2 | APM | Not Reporting | March-19 | |
| 3 | Behiating | Not Reporting | February-19 | |
| 4 | Bongaigaon (BTPS) | Partially Reporting | March-19 | SAS Upgradation in progress |
| 5 | Bordubi | Not Reporting | March-19 | SAS Upgradation in progress |
| 6 | Bornagar | Not Reporting | March-19 | SAS Upgradation in progress |
| 7 | Dullavcherra | Not Reporting | February-19 | |
| 8 | Gauripur | Not Reporting | February-19 | |
| 9 | Gossaigaon | Not Reporting | March-19 | |
| 10 | Lanka | Partially Reporting | March-19 | |
| 11 | Mariani | Partially Reporting | February-19 | |
| 12 | Nagaon | Not Reporting | March-19 | |
| 13 | Nazira | Not Reporting | March-19 | |
| 14 | Pailapool | Not Reporting | February-19 | |
| 15 | Rupia | Not Reporting | March-19 | |
| 16 | Sibsagar | Not Reporting | March-19 | SAS Upgradation in progress |
| 17 | Sipajhar | Partially Reporting | February-19 | SCADA Database to be checked |
| 18 | Tinsukia | Partially Reporting | March-19 | |
| 19 | Sonari | Not Reporting | March-19 | |
| 20 | Matia | Not Reporting | January-19 | AEGCL & PGCIL |
| 21 | Umrangsho | Partially Reporting | February-19 | |

| PHASE II APPROACH TO SOLVE THE TELEMETRY OF ASSAM | | | | |
|---|---------------------|---------------------|---|-----------------------------|
| Sl. No. | Substation | Status | Target | Issue |
| 1 | Badarpur(Panchgram) | Not Reporting | July-19 | |
| 2 | Biswanath Chariyali | Not Reporting | July-19 | SAS Upgradation in progress |
| 3 | Depota | Not Reporting | August-19 | |
| 4 | Dhemaji | Not Reporting | October-19 | PLCC & RTU issue |
| 5 | Haflong | Not Reporting | April-19 | |
| 6 | Hailakandi | Not Reporting | April-19 | |
| 7 | North Lakhimpur | Not Reporting | October-19 | |
| 8 | Lakwa (LTPS) | Not Reporting | NA to be taken with generation company | |
| 9 | Majuli | Not Reporting | NERPSIP should take the N.Lakhi-Gohpur Link on priority | |
| 10 | Margherita | Not Reporting | July-19 | |
| 11 | Namrup | Partially Reporting | NA to be taken with generation company | |
| 12 | Namrup PS1 | Not Reporting | NA to be taken with generation company | |
| 13 | Umrangsho | Partially Reporting | February-19 | |

Note PDH to be commissioned at Gohpur, Lakwa, Mariani and Namrup by Feb'19 by PGCIL

Gist of Discussions of Meeting on 24/01/2019

The meeting on preparation and joint verification of communication system in NER was attended by the following officers/executives:

| NERTS, POWERGRID | NERPSIP, PGCIL | AEGCL | NERLDC |
|---------------------------------|-------------------------------------|---|--|
| Shri. Rohitesh Kumar, AM (ULDC) | Shri. Himangshu Choudhury, Engineer | Shri. N Sharma, DGM Shri. P. Saha, AGM Shri. A Sarmah, DM | Shri. M K Ramesh, GM Shri. T Paul, AM Shri. Sakal Deep, Engineer |

The following has been discussed.

- The members studied and analysed detailed map of 18th RPC/TCC, NERPSIP and AEGCL map.
- 66 RTUs of AEGCL communication link to the respective SLDC was analysed for path diversification, existing single path issues with various communication media like PLCC and FO.
- The representative from NERPSIP has stated that work has started of links under NERPSIP Assam for the link between N. Lakhimpur and Gohpur.

The following are the observations:

- BTPS (AS)-Agia has only one link under MW vacation project.
 - There is a path diversification under AEGCL FO network.
 - Target is March'19.
 - BTPS (AS), Agia, Boko, Mirza, Amingaon, Rangia, Bornagar, Dhaligaon will be covered.
- Badarpur- Silchar link is completed.
 - Badarpur to Panchgram is connected in FO.
 - Badarpur (AS) → STM4 with 4 ethernet ports , each 100 mbps, 3 spare ports available.
- Srikona- Badarpur link is completed.
 - Badarpur- Kolasib completed, STM 4(Badarpur)
 - There is no alternate path for Badarpur (AEGCL) now.
 - KOLASIB to AIZWL completed
 - Srikona Panchgram link is not working due to tower collapse.
 - Panchgram is reporting through Badarpur.
 - Srikona reporting through Silchar.
- BTPS (AS) – SALAKATI (PG) completed.
 - BTPS (AS) is connected via Agia , BOKO , Mirza, Sarusajai, Kahilipara.
 - BADARPUR (AS), SRIKONA, PAILAPUR has STM 4 installed.
- MISA- SAMGURI is completed (MISA – STM 4, SAMAGURI- STM 4,)
 - Nagaon will be connected to SAMGURI or via STM1 of AEGCL.

Gist of Discussions of Meeting on 24/01/2019

- SAMGURI- MARIANI is completed (Mariani – STM 4)
 - Golaghat connected to mariani through plcc
 - Jorhat (Garmur) connected to Mariani through PLCC
 - Jorhat West connected to JORHAT through PLCC
 - Mariani is Wideband.
 - NAZIRA no RTU available. Target mentioned in the Annexure.

- Mariani- Lakwa completed
 - Old RTU- C264(SCT) in Lakwa, Namrup . Target mentioned in the Annexure.
 - Lakwa s/s data not coming- rtu issue- station data to be available after sas commissioning. Target mentioned in the Annexure.
 - Generating stations LTPS and LRPP will get wideband access from nearest AEGCL node i.e. Lakwa for their generation data. Target mentioned in the Annexure.

- Lakwa-Namrup link completed
 - NTPS and NRPP will get wideband access from nearest AEGCL i.e. Namrup node for their generation data.

- Namrup-Tinsukia completed
 - Tinsukia partially reporting – to be taken up with substation. Target mentioned in the Annexure.

- NERTS mentioned Mariani-Mariani(PG) link is not completed.
 - Target as per NETeST meeting.

- Balipara-Gohpur link is completed
 - BNC(AS) / Pavoil to Gohpur to be completed by July 19.
 - BNC(AS) / Pavoil- Lakhimpur-Dhemaji will get wideband access through Gohpur till NERPSIP for Lakhimpur-Dhemaji & Lakhimpur- Gohpur is completed. NERPSIP noted the same to complete the link on priority.
 - BNC(AS) / Pavoil RTU failure, card was burnt. Target of Apr 2019.

- Pilapool –Srikona completed
 - Pilapool gateway to be configured & connected.
 - Srikona two nos. bays of Silchar S/s (PG) are old and not in SAS.
 - AEGCL will go for alternate solution.

- Jiribam - Pilapool link is completed. Pilapool will be completed as per annexure.

- Jiribam- Badarpur link is not completed. Target as per NETeST meeting.
 - Pailapool and Srikona redundant path will be ensured with completion of the link.

- As per NERTS, STM16-Fibcom at SLDC Kahelipara is also under NER-FO project scope.
 - Early completion will help in better connectivity between control centres.

Gist of Discussions of Meeting on 24/01/2019

- PDH to be commissioned and configured for Gohpur, Mariani, Lakwa & Nampur by Feb' 2019 by NERTS, POWERGRID. This will help AEGCL for interfacing PLCC data and voice.
- Umrangshu is LILO b/w Khandong & Haflong
 - Not covered in any project.
 - At present Umrangshu is reporting via PLCC to Khandong (Wide Band).
- Betbari/Sibsagar, Nazira to be connected to Lakwa by February'2019.
- Based on the Maps given by NERPSIP and maps of 18th RPC communication Map, NERLDC has prepared a communication Map of NER. The prepared map has been verified by the members.
- Assam communication map given by the Assam executives is also to be superimposed with the current amalgamated map of NERTS and NERPSIP.
- Tail-ends stations, with no alternate path, are identified for Assam:
 - Halflong(AS), Lanka, Povai, Nazira, Nalbari and Rupai.
- Target dates for Assam RTUs/SAS are mentioned in the annexure.
- The committee members will review data availability by 1st week of April for Phase 1.

Rohitesh Kumar, AM
(ULDC)

Himangshu Choudhury,
Engineer

N Sharma, DGM

M K Ramesh, GM

P. Saha, AGM

T Paul, AM

A Sarmah, DM

Sakal Deep, Engineer



nerldc shillong <nerldccontrolroom@gmail.com>

Delay in collection of relay details of remotely controlled S/Ss

1 message

nerldc shillong <nerldccontrolroom@gmail.com>

Sun, Feb 24, 2019 at 1:52 PM

To: nerts cpcc <nerts_cpcc@powergrid.co.in>, nerts_rtamc@powergrid.co.in

Cc: V Suresh <vsuresh@posoco.in>, kaikhochin valte <kaikhochin@gmail.com>, R Sutradhar <rajibsutradhar@posoco.in>, S C De <scde@posoco.in>, Amresh Mallick <amareshmallick@posoco.in>

Sir,

This is to bring to you kind notice that relay details from site is not fully accessible from RTAMC, due to which collection of relay details after any line tripping are getting delayed for the remotely controlled S/Ss of POWERGRID. Which results delay in issue of closing code from NERLDC and hampers system security. As example

Today on 24.02.19 132kV Nirjuli - Lekhi line tripped at 11:05 Hrs but due to the delay in collection of tripping detail from Nirjuli, code for closing the line was issued at 11:20 Hrs only.

Hence necessary action may kindly be taken to reduce such delay.

सादर /Regards,

पाली प्रभारी/Shift-In-Charge
उत्तर पूर्वी भार प्रेषण केंद्र शिलांग
North Eastern Load Dispatch Centre Shillong



दूरभाष / Contact No- 0364-2537481/2537427/8415900659/ 8415900660

यू एल डी सी फोन नम्बर/ ULDC PH NO- 23640028/23640059

शेड्यूलिंग डेस्क/ Scheduling desk: 0374-2537470/ 23640027(ULDC)

फैक्स नम्बर /Fax- 0364- 2537486/2537470

**DISASTER MANAGEMENT - LIST OF CONTACT DETAILS OF NODAL OFFICERS/SECOND IN COMMAND UPDATED
ON 05/03/2019**

| Region/SLDC | Name | Designation | Tel. Nos. | Mobile No. | Fax No. | E-mail Address |
|-------------------------------|---------------------------|---|--------------|------------|--------------|--|
| NERLDC | | | | | | |
| Nodal Officer | R. Sutradhar | Sr. GM(SO -I) | 0364-2535710 | 9436302714 | 0364-2537470 | rajibsutradhar@posoco.in |
| Second in Command | A Mallick | Sr. GM(SO-2) | 0364-2535481 | 9436302720 | 0364-2537470 | amareshmallick@posoco.in |
| Arunachal Pradesh SLDC | | | | | | |
| Nodal Officer | N. Perme, | EE, SLDC | - | 9436288643 | - | sldcitnagar@gmail.com |
| Second in Command | Domo Kamduk | A.E (E) | 0360-2292160 | 9436671717 | 0360-2214358 | sldcitanagar@gmail.com |
| Assam/ AEGCL SLDC | | | | | | |
| Nodal Officer | Khireswar Gogoi | DGM, LDC | 0361-2381287 | 9435360066 | 0361-2387929 | kgogoi59@gmail.com |
| Second in Command | Bimal Chandra Borah | AGM, LDC | 0361-2381287 | 9435119248 | 0361-2387929 | bimalchandraborah@gmail.com |
| Manipur SLDC | | | | | | |
| Nodal Officer | L Dinesh Kumar Singh | GM (SLDC) | 0385-2436177 | 9862464974 | - | gmsldcmanipur@gmail.com |
| Second in Command | Liashram Ritu | DGM (System Operation), SLDC | 0385-2436192 | 9612882984 | - | redrit03@gmail.com |
| Meghalaya/ MeSEB SLDC | | | | | | |
| Nodal Officer | Shri F.E.Kharshiing | Superintending Engineer(SLDC) | - | 9863066960 | - | frederickek@gmail.com |
| Second in Command | Shri T.Gidon | Executive Engineer | - | 9774479956 | - | gidon@rediffmail.com |
| Mizoram SLDC | | | | | | |
| Nodal Officer | Lalbiaksanga | Superintending Engineer, SLDC | 0389 2311397 | 9436140932 | - | mSLDC.circle@gmail.com |
| Second in Command | Benjamin L. Tlumtea | Sr. Executive Engineer, SLDC | 0389 2328322 | 9436151424 | - | bltlumtea@yahoo.com |
| Nagaland SLDC | | | | | | |
| Nodal Officer | Er. Nitovi A Wotsa | Executive Engineer (Transmission & SLDC) | - | 9436004928 | - | nitoviv@gmail.com |
| Second in Command | Er. Debabrata Chakraborty | Sub-Divisional Officer (SLDC) | - | 7577950317 | - | chakra2500@gmail.com |

**DISASTER MANAGEMENT - LIST OF CONTACT DETAILS OF NODAL OFFICERS/SECOND IN COMMAND UPDATED
ON 05/03/2019**

| Region/SLDC | Name | Designation | Tel. Nos. | Mobile No. | Fax No. | E-mail Address |
|---------------------|-------------------------|------------------------------|------------------|----------------------------|--------------|--|
| Tripura SLDC | | | | | | |
| Nodal Officer | Er. Anil Debbarma | DGM, Electrical | 0381-2356470 | 7005709452 | 0381-2350795 | anildebbarma123@gmail.com |
| Second in Command | Er. Mrinal Pal | Manager, Electrical | 0381-2356470 | 9436137022 | - | mrinalpaulnit@gmail.com |
| NERTS | | | | | | |
| Nodal Officer | U. Katak | Sr. GM | - | 9435505418 | - | u.katak@powergridindia.com |
| Second in Command | P. Kanungo | Sr. GM | 0364-2537328 | 9436302823 | Nil | kanungo_p@yahoo.com |
| NEEPCO | | | | | | |
| Nodal Officer | B. Goswami | Sr. Mgr. | 0364-2504355 | 9436163983 | 0364-2221789 | bhaskargoswami@rediffmail.com |
| Second in Command | Joypaul | Sr. Mgr. | 0364-2226707 | 943557772 | 0364-2221789 | joypal_roy@rediffmail.com |
| NHPC | | | | | | |
| Nodal Officer | K. T. Rajah Pandian | General Manager(Electrical) | 03879-261739 | 7085057135 | - | ktrajahpandian@yahoo.co.in |
| Second in Command | N. Yugandhar | Senior Manager (E & C) | 03879-261237 | 9800003819 | - | loktakphop@gmail.com |
| NETC | | | | | | |
| Nodal Officer | Sh. D.K. Sarma | Sr. Consultant, Guwahati. | - | 9471001032 / 8638481689 | - | dkarma@netcindia.in |
| Second in Command | Ratan Singh Basnet | Assistant Manager, Guwahati. | - | 8811072489 / 7002809257 | - | ratansinghasnet@netcindia.in |
| NTPC | | | | | | |
| Nodal Officer | Sri Chandan Chakraborty | Chief General Manager | 03661 282754/ 34 | 9650994355 | 03661 282726 | chandanchakraborty@ntpc.co.in |
| Second in Command | Sri Rakesh Kumar | General Manager (O&M) | 03661 282712 | 9431011344 | - | rakeshkumar12@ntpc.co.in |
| OTPC | | | | | | |
| Nodal Officer | Bibek Roy | Plant In-Charge | 0381 2363875 | 8794006803 | 3812363714 | bibek.roy@otpcindia.in |
| Second in Command | Narendra Kumar Gupta | Sr. Manager - Operation | 0381 2363806 | 9774233426 | 3812363714 | nk.gupta@otpcindia.in |

**DISASTER MANAGEMENT - LIST OF CONTACT DETAILS OF NODAL OFFICERS/SECOND IN COMMAND UPDATED
ON 05/03/2019**

| Region/SLDC | Name | Designation | Tel. Nos. | Mobile No. | Fax No. | E-mail Address |
|--------------------|--------------|--------------------|------------------|-------------------|----------------|--|
| NERPC | | | | | | |
| Nodal Officer | B. Lyngkhoi | Director/SE | | 9436163419 | | b_lyngkhoi@yahoo.com |
| Second in Command | S. Mukherjee | AD-I/AEE | | 8794277306 | | nerpc@ymail.com |

पावर सिस्टम ऑपरेशन करपोरेशन लिमिटेड
(भारत सरकार का उद्यम)
POWER SYSTEM OPERATION CORPORATION LIMITED
(A Government of India Enterprise)



उत्तर पूर्वी क्षेत्रीय भार प्रेषण केंद्र : लोअर नंगरा, लापालांग, शिलांग-793006, (मेघालय)
North Eastern Regional Load Despatch Centre: Lower Nongrah, Lapalang, Shillong - 793006, (Meghalaya)
Ph : 0364-2537470, 2537427, Fax - 2537486 Website : www.nerlhc.org, Email - nerlhc@posoco.in, CIN : U40105DL2009GOI188682

संदर्भ : उपक्षेभाप्रेके/एस.ओ-11/2855

दिनांक/Date: 06.03.19

सेवा में,

1. As per distribution list

प्रतिलिपि:

1. Member Secretary, NERPC, Shillong- 793006

विषय: POSOCO Compliance_ROP in Petition No 237/MP/2017 along with IA No 11/2018

संदर्भ: POSOCO/NLDC/LVRT/2019/02 dated 28.02.19

महोदय,

The Record of Proceedings (ROP) in Petition no. 237/MP/2017 along with IA no. 11/2018 enclosed at **Annexure- 1** was issued by Hon'ble Commission and was posted on its website on 08th Feb 2019. As per Para (4) of the ROP, Commission has directed POSOCO to submit the States Wind Turbine Generator (WTG)-wise data containing

- (i) Population of wind turbines as per models, make and voltage levels, and
- (ii) Details of Low Voltage Ride Through (LVRT) enabled, LVRT design supported and LVRT to be retrofitted.

As per Para (7) of ROP, Hon'ble Commission directed POSOCO to coordinate with the RPCs for taking up a consolidated case for funding from PSDF/Green Fund for retrofitting WTGs with LVRT in terms of order dated 5.1.2016 in Petition No. 420/MP/2014. Further as per Para (8) of ROP the information needs to be submitted within one month from the issue of the ROP.

A format has been drafted to obtain the WTGs details in line with requirement mentioned at Para (4) of the ROP which is enclosed as **Annexure-2**. It is requested that the details may kindly be submitted within 07.03.19 for onward submission to Hon'ble Commission.

धन्यवाद एवं सादर सहित।

Enclosure: As mentioned above.

भवदीय / Yours sincerely

(समर चन्द्र डे / Samar Chandra Dey)

महाप्रबंधक (एस.ओ-2) G.M. (S.O.-II)

उपक्षेभाप्रेके, शिलांग / NERLDC, Shillong

Distribution List:

1. Executive Engineer, SLDC and Transmission Division Itanagar, Raj Bhawan Power House, Itanagar, Arunachal Pradesh- 791111
2. CGM, SLDC Assam, AEGCL, Near 132 kV Grid Substation, Kahilipara, Guwahati – 781019
3. General Manager, SLDC, MSPCL, Imphal, Manipur – 795001
4. Superintending Engineer, SLDC Meghalaya, NEHU Substation, Shillong - 793022
5. Superintending Engineer, SLDC Mizoram, Power House, Electric Veng, Aizawl, Mizoram – 796001
6. Executive Engineer (Transmission), SLDC Nagaland, DoP Nagaland, Electricity Colony, Full Nagarjan, Dimapur, Nagaland – 797112
7. DGM (System Operation), SLDC Agartala, TSECL, 79-Tilla, Tripura (West), Agartala – 799006

CENTRAL ELECTRICITY REGULATORY COMMISSION NEW DELHI

Petition No.237/MP/2017 Along with I.A. No. 11/2018

- Subject : Petition preferred under Section 94 (1)(f) of the Electricity Act, 2003 for seeking extension of time prescribed for implementation of the Central Electricity Regulatory Commissions Order dated 5 January, 2016 in Petition No. 420/MP/2014 in the matter of Endangering grid security due to non-implementation of contingency demand disconnection scheme for sudden loss of wind generation, non-availability of LVRT protection, non scheduling of wind generation as per CERC (Indian Electricity Grid Code) Regulations, 2010 (IEGC) 6.5.23 (i), lack of necessary demand estimation as per IEGC Regulation 5.3 and not providing real time SCADA data to LDC., and for seeking relief to specific provisions of the aforementioned Order. (Interlocutory application seeking extension of timeline for implementation of the order dated 5.1.2016 in Petition No. 420/MP/2014
- Date of hearing : 31.1.2019
- Coram : Shri P.K. Pujari, Chairperson
Dr. M.K. Iyer, Member
Shri I.S.Jha, Member
- Petitioner : Suzlon Energy Limited (SEL)
- Respondents : Southern Regional Load Despatch Centre and Others
- Parties present : Ms. Shikha Ohri, Advocate, SEL
Shri Nishant Kumar, Advocate, SEL
Shri N.K. Deo, SEL
Shri Shatrajit Banerjee, SLDC & POSOCO
Shri Aman Senghama, SLDC & POSOCO
Shri G. Chakraborty, POSOCO
Shri T. Kalanithy, SRLDC & POSOCO
Shri Venkateshan.M, SRLDC & POSOCO

Record of Proceedings

At the outset, learned counsel for the Petitioner submitted that the Petitioner is willing to implement the LVRT solution. However, certain clarity is required on technical aspects. Learned counsel further submitted that as per the Commission's order dated 5.1.2016 in Petition No. 420/MP/2014, Regional Power Committees made a proposal for funding from PSDF and NCEF Green fund for retrofitting wind turbines with LVRT. However, there is no development in this regard. Learned counsel for the Petitioner

submitted that the Petitioner has approached the RERC for tariff adjustment and the matter is under consideration.

2. The Representative of the POSOCO submitted that funding can be provided only to such generators who are supplying power to the distribution companies. The representative of POSOCO submitted that in terms of the order dated 5.1.2016 in Petition No. 420/MP/2014, RPCs are required to make proposal for arrangement of funding for PSDF/NCEF/Green Fund for retrofitting of WTGS with LVRT.

3. After hearing the learned counsel for the Petitioner and the Representatives of the Respondents, the Commission directed the Petitioner to approach all the State Commissions for tariff adjustment proposal.

4. The Commission further directed the POSOCO to submit the States WTG-wise data containing (i) population of wind turbines as per models, make and voltage levels, and (ii) details of LVRT enabled, LVRT design supported and fitted to be enabled, LVRT design supported but to be fitted and LVRT to be retrofitted.

5. The Commission directed the CEA to submit the study regarding technical feasibility of installation of LVRT in WTG in terms of the order dated 5.1.2016 in Petition No.420/MP/2014.

6. The Commission observed that the Wind Power Developers should approach the concerned SERCs for allowing the cost of retrofitting, WTGs-wise LVRT in terms of the applicable regulations of the SERCs and the PPAs.

7. The Commission directed POSOCO to coordinate with the RPCs for taking up a consolidated case for funding from PSDF/Green Fund for retrofitting WTGs with LVRT in terms of order dated 5.1.2016 in Petition No. 420/MP/2014.

8. The Commission directed the parties to file the above information within one month from the issue of the ROP.

9. The Commission directed that the interim direction dated 10.4.2018 shall be continued till the disposal of the Petition.

10. Subject to the above, the Commission reserved order in the Petition.

By order of the Commission

**Sd/-
(T. Rout)
Chief (Law)**

STANDARD FORMAT FOR
FURNISHING TECHNICAL PARAMETERS REQUIRED FOR DYNAMIC
MODELLING FOR START-UP POWER AND FIRST TIME SYNCHRONIZATION OF
GENERATORS

1. Synchronous Machine Details

| Sl No. | ID | Information | Enter Values or use as Checklist (Yes/No/Submitted etc) |
|---------------|--|---|--|
| 1 | Generator Nameplate | Rated apparent Power in MVA | |
| | | Rated terminal Voltage | |
| | | Rated power factor | |
| | | Rated speed (in RPM) | |
| | | Rated excitation (in Amperes and Volts) | |
| 2 | Generator Datasheets | To be submitted | |
| 3 | Type of synchronous Machine | Round rotor or salient pole. Determines what type of synchronous machine model to use (for example GENROE is for a round rotor machine and GENSAL is for a salient pole machine) | |
| 4 | Generator capability curve | The generator capability curve shows the reactive capability of the machine and should include any restrictions on the real or reactive power range like under/over excitation limits, stability limits, etc. | |
| 5 | Generator Open Circuit and Short Circuit Characteristic | Graph of excitation current versus terminal voltage and stator current | |
| 6 | Generator vee-curves | Otherwise referred to as “V-curve”. | |
| | | The generating unit V-curve is a plot of the terminal (armature) current versus the generating unit field voltage. | |
| 7 | Unbalanced Load-Time Curve | To be submitted (if available) | |

| | | | |
|----|--|---|--|
| 8 | Asynchronous Capability Curve | To be submitted (if available) | |
| 9 | Resistance values | Resistance measurements of field winding and stator winding to a known temperature (Please mention value of T) [Used to derive per unit value for excitation voltage and stator resistance (Ra)] | |
| 10 | Generator step up transformer (GSUT) | Nameplate Rated primary and secondary voltages – Vector group – Impedance – Tap changer details- | |
| 11 | Generator Transformer Data Sheet | Datasheet is to be furnished. If not available, photograph of name plate is to be furnished | |
| 12 | Auxiliary power (i.e. active and reactive auxiliary load) | Value of auxiliary load (MW and Mvar) at rated power of the generating unit. Whether or not the load trips if the generating unit trips. | |

2. Synchronous Machine Parameters

The parameters shown in this Table are used to represent and model a synchronous machine:

| Sl No | Parameter | Description | Unit | Remark | Value |
|-------|-----------|--|--------------|-----------------------------------|-------|
| 1 | Xd | Direct axis synchronous reactance | pu | Unsaturated or saturated | |
| 2 | Xd' | Direct axis transient synchronous reactance | pu | Unsaturated or saturated | |
| 3 | Xd'' | Direct axis sub-transient synchronous reactance | pu | Unsaturated or saturated | |
| 4 | Xa | Stator leakage reactance | pu | Unsaturated or saturated | |
| 5 | Xq | Quadrature axis synchronous reactance | pu | Unsaturated or saturated | |
| 6 | Xq' | Quadrature axis transient synchronous reactance | pu | Unsaturated or saturated | |
| 7 | Xq'' | Quadrature axis sub-transient synchronous reactance | pu | Unsaturated or saturated | |
| 8 | Tdo' | Direct axis open circuit transient time constant | s | | |
| 9 | Tdo'' | Direct axis open circuit sub-transient time constant | s | | |
| 10 | Tqo' | Quadrature axis open circuit transient time constant | s | | |
| 11 | Tqo'' | Quadrature axis open circuit sub-transient time constant | s | | |
| 12 | H | Inertia Constant | MW.s/ MVA | Total rotating mass | |
| 13 | S(1.0) | Saturation Constant | pu | Can be calculated from OCC Curves | |
| 14 | S(1.2) | Saturation Constant | pu | | |

3. Site Load

Loads used for steady-state (i.e. load flow) simulations for representing the Power Station

| | Low Output | | | High Output | | |
|-----------|------------|------|-----|-------------|------|-----|
| | kW | kVAR | kVA | kW | kVAR | kVA |
| Auxiliary | | | | | | |

4. Protection Systems

| SI No | Equipment Name | Information | Furnished (Yes/No) |
|-------|----------------------------|--|--------------------|
| 1 | Generator | Please furnish the list of Electrical and Mechanical Protection Functions (as per list in CEA Regulation) and settings in available format | |
| 2 | Generator Transformer | | |
| 3 | Unit Auxiliary Transformer | | |
| 4 | Station Transformer | | |

5. Excitation System Details

| SI No | ID | Information | Enter Values or use as Checklist (Yes/ No/ Submitted etc.) |
|-------|--|--|--|
| 1 | Type of Automatic Voltage Regulator (AVR) | <p>Manufacturer and product details (for example ABB UNITROL)</p> <p>Analogue or digital control system</p> <p>Year of commissioning</p> <p>Present settings (obtained either from HMI or downloaded from controller in digital systems)</p> | |
| 2 | Transfer Function of AVR | IEEE Model with all parameters & Control Block Diagram to be submitted | |
| 3 | Schematics of Excitation System and AVR Scheme | <p>Drawings of excitation system, typically prepared and supplied by the OEM</p> <p>Single line diagram (i.e. one-line diagram) for the excitation system</p> | |
| 4 | Operating Instructions of AVR | Please furnish (if available) | |
| 5 | Test Instruction and Test Report of AVR | Please furnish (if available) | |
| 6 | Type of excitation system | <p>Static excitation system OR Indirect excitation system (i.e. rotating exciter)</p> <ul style="list-style-type: none"> - AC exciter, or - DC exciter | |
| 7 | Details of AVR | Rated excitation current (converter rating in | |

| | | | |
|-----------|---|---|--|
| | converter | Amperes) Six pulse thyristor bridge or PWM converter | |
| 8 | Source of excitation supply | Excitation transformer or auxiliary supply If excitation transformer, please furnish nameplate information and protection functions and settings | |
| 9 | PSS | Is the AVR equipped with a PSS? How many input Channels does the PSS have? If the PSS uses speed, is this a derived speed signal or measured directly? PSS settings | |
| 10 | Schematic Diagram and Transfer Function of PSS | If PSS is available, please furnish the schematic diagram and Transfer Function with control block of PSS along with all parameters | |
| 11 | Excitation limiters | What excitation limiters are commissioned? UEL OEL V/f limiter Stator current limiter Minimum excitation current limiter Others | |

6. Turbine Governor Details – (For Thermal & Gas) Machines

| Sl No | ID | Information | Enter Values or use as Checklist (Yes/No/Submitted etc) |
|-------|---|--|---|
| 1 | Turbine – Governor Transfer Function Model | IEEE Model with all parameters & Control Block Diagram to be submitted | |
| 2 | Turbine – Governor Schematic Diagram | Schematic Diagram showing the installations and flow is to be submitted | |
| 3 | Turbine- Governor Operation Manual | Please furnish (if available) | |
| 4 | Type of prime mover | Mention the type of prime mover: Steam turbine Open cycle gas turbine Aero-derivative (twin shaft) gas turbine Combined cycle plant Other | |
| 5 | Manufacturer of turbine | Please include name of Manufacturer | |
| 6 | Type of fuel | Coal (brown or black) Gas Diesel (liquid fuel) Other | |
| 7 | Governor | Whether- Electro-mechanical governor Digital electric governor Any Other | |
| 8 | Ramp rates | How fast can the turbine increase and/or decrease load, specified in MW/min | |
| 9 | RGMO/FGMO Settings | <p>Droop setting (% on machine base)</p> <p>Frequency influence limiters</p> <ul style="list-style-type: none"> • Maximum frequency deviation limiter (eg +/-2 Hz) • Maximum influence limiter (eg 10% of rating) <p>Ripple Factor</p> <p>Operating Frequency Range</p> <p>Under Frequency/Over Frequency Values</p> <p>Under Speed/ Over Speed Values</p> | |

| | | | |
|----|-----------------------------|---|--|
| 10 | Dead-band | Details of frequency dead-band (typically in Hz or RPM) | |
| 11 | Technology | Coal: <ul style="list-style-type: none"> • Sub-critical (Steam pressure = x MPa) • Super-critical (Steam pressure = x MPa) Gas/distillate: <ul style="list-style-type: none"> • Open cycle • Combined cycle • Engine Any other:- | |
| 12 | Steam turbine | Please mention which of the following are available:- Tandem compound: all sections on one shaft with a single generator Cross compound: consists of two shafts, each connected to a generator and driven by one or more turbine sections Turbine sections: High pressure (HP), intermediate pressure (IP) and low pressure (LP) Reheat or non-reheat: In a reheat, steam upon leaving HP section returns to boiler where it is passed through re-heater before entering IP section | |
| 13 | Gas turbine | Type of gas turbine: open cycle heavy duty, aero derivative twin shaft gas turbine Does turbine operate in dual fuel (gas and liquid fuel) Inlet guide vane characteristic Limit for exhaust gas temperature (EGT) Base load / frequency control | |
| 14 | Combined cycle plant | Details on heat recovery steam generator (HRSG) Size of steam turbine (MW) Frequency control of ST Time lag and relationship of GT and ST Is the combined cycle plant a single-shaft plant – i.e. the gas and steam turbine are on same shaft and drive same generator | |

7. Turbine Governor Details – (For Hydro) Machines

| Sl No | ID | Information | Enter Values or use as Checklist (Yes/No/Submitted etc) |
|-------|---|--|---|
| 1 | Turbine – Governor Transfer Function Model | IEEE Model with all parameters & Control Block Diagram to be submitted | |
| 2 | Turbine – Governor Schematic Diagram | Schematic Diagram showing the installations and flow is to be submitted | |
| 3 | Turbine- Governor Operation Manual | Please furnish (if available) | |
| 4 | Type of prime mover | Hydro Electric Turbine Other (Pumped Storage) | |
| 5 | Manufacturer of turbine | Please include name of Manufacturer | |
| 6 | Modes of operation | Types of modes of operation capable: - Generator - Pump - Synchronous condenser -Any Other Modes | |
| 7 | Governor | -Electro-mechanical governor (including settings and drawings) -Digital electric governor (including settings and drawings) -PID governor details and settings -Transient droop (Dashpot) governor details and settings -Tacho- accelerometric governor details and settings Input transducer details | |
| 8 | Ramp rates | How fast can the turbine increase and/or decrease load, specified in MW/min | |
| 9 | RGMO/FGMO Settings | Droop setting (% on machine base) Frequency influence limiters <ul style="list-style-type: none"> • Maximum frequency deviation limiter (eg +/-2 Hz) • Maximum influence limiter (eg 10% of rating) Ripple Factor Operating Frequency Range | |

| | | | |
|-----------|-------------------------------|---|--|
| | | Under Frequency/Over Frequency Values Under Speed/ Over Speed Values | |
| 10 | Dead-band | Details of frequency dead-band (typically in Hz or RPM) | |
| 11 | Hydro-electric turbine | Type of hydro turbine -Impulse turbines – typical with high-head plants (Pelton wheel) -Reaction turbine – typical with low- and medium-head plants (such as Francis and Kaplan turbine) Water flow, velocity and pressure (e.g. intake and outtake/draft tube) | |
| 12 | Penstock | -Length (m) -Area (m ²) -Internal penstock diameter -Pipe thickness, material or other characteristics (such as tapering) -Non-elastic or elastic -Linear or non-linear model (with or without relief valve) or Kaplan model -Flow of water through turbine (m ³ /s) – with gates fully open -Number of penstocks supplied from common tunnel | |
| 13 | Pressure relief valve | Drawings/schematics Settings Operational descriptions | |
| 14 | Pipe and Tunnel | Diameter of pipe Thickness Material Length | |

| | | | |
|-----------|---|---|--|
| | | Linear or non-linear model | |
| 15 | Surge tank, reservoir and tail water (i.e. Head) | <p>Vertical distance between the upper reservoir and level of turbine (in meters)</p> <p>Head at turbine admission (lake head minus tailrace head) – (in meters)</p> <p>Head loss due to friction in conduit (in metres)</p> <p>Surge tank height, diameter and other characteristics (e.g. restricted inlet orifice)</p> | |
| 16 | Other | <p>Details of protection schemes that could influence dynamics (if any)</p> <p>Details of resonance chambers for pipes (if any)</p> <p>Temperature (e.g. water, ambient, unit)</p> | |

-----XXXXXXXXXXXXXXXXXXXX-----