



भारत सरकार Government of India

विद्युत मंत्रालय Ministry of Power

उत्तर पूर्वी क्षेत्रीय विद्युत समिति

North Eastern Regional Power Committee

एन ई आर पी सी कॉम्प्लेक्स, डोंग पारमाओ, लापालाङ, शिल्लोंग-७९३००६, मेघालय
NERPC Complex, Dong Parmaw, Lapalang, Shillong - 793006, Meghalaya

Ph. No: 0364 - 2534039

Fax No: 0364 - 2534040

Website: www.nerpc.nic.in

No. NERPC/SE (O)/OCC/2019/2685-2722

Dated: February 28, 2019

To,

1. Managing Director, AEGCL, Bijuli Bhawan, Guwahati – 781 001
2. Managing Director, APDCL, Bijuli Bhawan, Guwahati – 781 001
3. Managing Director, APGCL, Bijuli Bhawan, Guwahati – 781 001
4. Director (Generation), Me. PGCL, Lumjingshai, Short Round Road, Shillong – 793 001
5. Director (Distribution), Me. ECL, Lumjingshai, Short Round Road, Shillong – 793 001
6. Director(Transmission), Me. PTCL, Lumjingshai, Short Round Road, Shillong – 793 001
7. Managing Director, MSPDCL, Secure Office Bldg. Complex, South Block, Imphal – 795 001
8. Managing Director, MSPCL, Electricity Complex, Keishampat, Imphal – 795 001
9. Director (Tech.), TSECL, Banamalipur, Agartala -799 001.
10. Director (Generation), TPGCL, Banamalipur, Agartala -799 001.
11. Chief Engineer (WE Zone), Department of Power, Govt. of Arunachal Pradesh, Itanagar- 791111
12. Chief Engineer (EE Zone), Department of Power, Govt. of Arunachal Pradesh, Itanagar- 791111
13. Chief Engineer (TP&MZ), Department of Power, Govt. of Arunachal Pradesh, Itanagar- 791111
14. Engineer-in-Chief (P&E), Department of Power, Govt. of Mizoram, Aizawl – 796 001
15. Chief Engineer (P), Department of Power, Govt. of Nagaland, Kohima – 797 001
16. CGM, (LDC), SLDC Complex, AEGCL, Kahilipara, Guwahati-781 019
17. Group General Manager, NTPC, Bongaigoan Thermal Power Project, P.O. Salakati, Kokrajhar- 783369
18. ED, NERTS, PGCIL, Dongtiah-Lower Nongrah, Lapalang, Shillong -793 006
19. ED (O&M), NEEPCO Ltd., Brookland Compound, Lower New Colony, Shillong-793003
20. ED (Commercial), NEEPCO Ltd., Brookland Compound, Lower New Colony, Shillong-793003
21. ED (O&M), NHPC, NHPC Office Complex, Sector-33, Faridabad, Haryana-121003
22. Vice President (Plant), OTPC, Badarghat Complex, Agartala, Tripura - 799014
23. GM, NERLDC, Dongtiah, Lower Nongrah, Lapalang, Shillong -793 006
24. Member Secretary, ERPC, 14 Golf Club Road, Tollygunge, Kolkata-700033
25. Chief Engineer, GM Division, Central Electricity Authority, New Delhi – 110066
26. Chief Engineer (NPC), NRPC Complex, Katwaria Sarai, SJSS Marg., New Delhi - 110016

Sub: Minutes of 153rd OCC Meeting.

Sir/Madam,

Please find enclosed herewith the minutes of 153rd OCC Meeting held at Agartala on the **14th February, 2019** for your kind information and necessary action. The minute is also available on the website of NERPC, www.nerpc.nic.in.

Any comments/observations may kindly be communicated to NERPC Secretariat at the earliest.

Encl: As above

भवदीय / Yours faithfully,

बि. लिंगखोइ / B. Lyngkhoi

निदेशक / Director/ SE

Copy to:

1. CGM, AEGCL, Bijuli Bhavan, Guwahati - 781001
2. CGM, APGCL, Bijuli Bhavan, Guwahati - 781001
3. CGM, DISCOM, Bijuli Bhavan, Guwahati - 781001
4. Head of SLDC, Me.ECL, Lumjingshai, Short Round Road, Umjarain, Shillong – 793 022
5. Head of SLDC, Department of Power, Govt. of Arunachal Pradesh, Itanagar- 791 111
6. Head of SLDC, Department of Power, Dimapur, Nagaland
7. Head of SLDC, Electricity Department, Govt. of Manipur, Keishampat, Imphal – 795 001
8. Head of SLDC, Department of Power, Govt. of Mizoram, Aizawl – 796 001
9. Head of SLDC, TSECL, Agartala – 799 001
10. Chief Engineer(Elect), Loktak HEP, Vidyut Vihar, Kom Keirap, Manipur- 795124
11. Addl. GM (EED), NTPC Ltd., Bongaigoan Thermal Power Project, P.O. Salakati, Kokrajhar- 783369
12. DGM (C&M), OTPC, 6th Floor, A-Wing, IFCI Tower -61, Nehru Place, New Delhi – 110019.



निदेशक / Director/ SE

North Eastern Regional Power Committee

MINUTES OF THE 153rd OPERATION COORDINATION

SUB-COMMITTEE MEETING OF NERPC

Date : 14/02/2019 (Thursday)
Time : 12:00 hrs
Venue : "State Guest House", Agartala.

The List of Participants in the 153rd OCC Meeting is attached at **Annexure – I**

Shri P.K. Mishra, Member Secretary, NERPC welcomed all the participants to the 153rd OCC meeting. He mentioned that OCC Meetings are usually held in Guwahati to enable large participation from all NER Constituents. However, due to Milaap – 2.0 of OTPC, the 153rd OCC is being held in Agartala for successful conclave of OTPC. He expressed satisfaction about large number of participation and thanked all the members for their enthusiastic participation. He also thanked TSECL and their teams for hosting the meeting. He requested all to actively participate in the meeting for fruitful deliberations.

Thereafter, Member Secretary requested Shri B. Lyngkhoi, Director (O&P) to take up the agenda for discussion. Director, NERPC informed the forum that a presentation on Security Constrained Economic Despatch(SCED) will be given by POSOCO.

A. CONFIRMATION OF MINUTES

CONFIRMATION OF MINUTES OF 152nd MEETING OF OPERATION SUB-COMMITTEE OF NERPC.

The minutes of 152nd meeting of Operation Sub-committee held on 11th January, 2019 at Guwahati were circulated vide letter No. NERPC/SE (O)/OCC/2016/4556-4591 dated 21st January, 2019.

MeECL vide mail dated. 22.01.2019 has requested for amendment to item No. **D.18** as follows:

The Executive Engineer, SLDC, Meghalaya, pointed out the following:

- a. He expressed concerned of late information and the matter could have been informed to the forum in the previous OCC meetings just after the monsoon recedes so as to find out ways to meet the expenditure thus involved.
- b. Further, since the landslide and soil erosion was due to excessive and unprecedented heavy rainfall during the last monsoon, NETC may first approach the Government for obtaining fund under National Disaster Response Fund. Therefore, NETC may approach the Government for the same.
- c. Adding the expenditure to POC Charges will put additional burden on the consumers. It is therefore, requested to the forum to find other alternatives source to meet the expenditure and to consider payment from POC charges as the last option.
- d. SLDC, Arunachal Pradesh supported the views and request made by SLDC, Meghalaya

The Sub-committee confirmed the minutes of 152nd OCCM of NERPC with above Amendments as no other comments/observations were received from the constituents.

ITEMS FOR DISCUSSION

B.1. ACTION TAKEN:

1. IMPLEMENTATION OF PROJECTS FUNDED FROM PSDF:

The status as informed in 152nd OCC:

State	R&U scheme	ADMS	Capacitor Installation	SAMAST **	Line Differential Protection
Ar. Pradesh	Pkg-I: OBD completed. By Feb'19 LOA. Pkg-II: Tendering in process.	To submit comments to NIT by 18/02.	-	TESG queries submitted.	-
Nagaland	Pack-B: Dec'18 Pack-C: Dec'18	To submit comments to NIT by 18/02.	To submit re-proposal to NERPC for Study.	TESG queries to be submitted.	Lines identified. Under DPR preparation stage.

Mizoram	LOAs issued. Completion by Mar'19.	To submit comments to NIT by 18/02.	To re-submit proposal to NERPC for Study.	TESG queries submitted.	Lines not yet identified. To be taken up in Sub-group.
Manipur	LOAs issued. Completion by Nov'18.	To submit comments to NIT by 18/02.	Submitted to NERPC for Study before sending to NPC/NLDC.	TESG queries to be submitted.	Lines not yet identified. To be taken up in Sub-group.
Tripura	90% completed. Remaining by Feb'19	To submit comments to NIT by 18/02.	To submit proposal to NERPC for Study.	TESG queries submitted.	Lines not yet identified. To be taken up in Sub-group.
Assam	Substation auxiliary and diagnostics tools - Tendering in process. LOA by Dec'18.	To submit comments to NIT by 18/02.	-	TESG queries submitted.	Lines identified. Under DPR preparation stage.
Meghalaya	MePTCL LOA issued, 95% completed. Remaining LOAs by Feb'19. Commissioning works 60% completed, Total balance works by Jun'19. MePGCL - Erection complete by Mar'19	Revised DPR submitted. Query referred to DISCOM	-	TESG queries submitted.	DPR already submitted and awaited approval.

Deliberation of the sub-Committee:

Sr. GM(MO), NERLDC intimated that queries of TSEG pertaining to SAMAST has been replied by all NER States and approval of grant from PSDF is awaited. It was decided

by the forum to initiate modalities for Tendering in the meantime and complete by 1st. week of March'19.

The Sub-Committee noted as above.

Action: All state utilities/NERPC.

2. Outage of Important Grid Elements:

Name of the Element	Name of Utility	Status as informed in 152 nd OCC
63MVAR Reactor at Byrnihat to replace with 80MVAR Reactor	MePTCL	To be updated in MoM. PGCIL agreed to share the sample bid document to MePTCL within March 2019.
Outage of 420kV 80MVAR L/R for 400kV Bongaigaon-NSLG-I at Bongaigaon - (out since 04.07.18)	NERTS	By February, 2019
132kV Dimapur - Imphal (out since 25.07.18)	NERTS	By March, 2019
220kV Sonabil-Samaguri-I	AEGCL	Tender by March, 2019
420kV 80 MVAR Bus Reactor at 400 kV Imphal S/S (out since 21:05 Hrs of 25.12.18)	NERTS	Charged on 26.01.2019. Issue may be dropped.
420kV 63 MVAR Line Reactor at 400 kV Bongaigaon S/S for 400kV Bongaigaon- Azara (out since Nov'18)	NERTS	After 9th March'19 due to outage of ICT # 1 at Misa and 220kV Bus # 1 & 2 at Kopili

The Sub-Committee noted as above.

Action: All concerned utilities & NERPC.

DIFFERENCE IN ACTUALS VS LGBR:

Energy Requirement:

Name of State	Sep 18 (actual)	Sep 18 (LGBR)	Oct 18 (actual)	Oct 18 (LGBR)	Nov 18 (actual)	Nov 18 (LGBR)	Dec 18 (actual)	Dec18 (LGBR)
Ar. Pradesh	74.16	71.19	70.06	77.25	67.34	77.97	75.90	72.19
Assam	950.19	934.64	815.67	885.83	707.55	707.17	691.41	719.43
Manipur	69.88	69.64	75.80	75.56	81.80	78.59	89.09	87.43
Meghalaya	150.14	164.00	144.61	166.00	163.83	169.00	192.05	175.00
Mizoram	58.04	39.37	70.64	44.19	67.71	47.06	53.75	56.60
Nagaland	80.49	76.88	74.27	69.66	61.04	64.67	79.63	80.10
Tripura	192.00	125.18	187.38	132.09	164.71	98.49	165.65	96.16

Energy Availability:

Name of State	Sep 18 (actual)	Sep 18 (LGBR)	Oct 18 (actual)	Oct 18 (LGBR)	Nov 18 (actual)	Nov 18 (LGBR)	Dec 18 (actual)	Dec18 (LGBR)
Ar. Pradesh	81.12	82.62	67.90	77.45	64.46	63.39	61.98	57.96
Assam	987.64	859.96	772.79	898.78	747.84	795.50	748.10	765.58
Manipur	177.79	110.48	105.39	117.42	85.54	106.01	101.86	87.00
Meghalaya	276.17	308.96	200.13	274.43	175.54	206.71	206.14	194.14
Mizoram	111.76	89.77	106.29	83.22	89.63	69.34	67.34	58.83
Nagaland	81.24	87.96	68.17	88.06	53.51	72.04	63.19	65.59
Tripura	309.44	268.15	342.04	300.01	332.36	272.69	336.56	280.83

Demand:

Name of State	Sep 18 (actual)	Sep 18 (LGBR)	Oct 18 (actual)	Oct 18 (LGBR)	Nov 18 (actual)	Nov 18 (LGBR)	Dec 18 (actual)	Dec18 (LGBR)
Ar. Pradesh	131.92	143	129.08	146.00	127.77	145.00	132.80	140.00
Assam	1865.26	1787.60	1785.42	1840.56	1546.54	1558.56	1440.10	1506.61
Manipur	184.39	168.04	187.28	175.61	189.23	182.53	213.75	196.00
Meghalaya	317.42	328.18	336.23	320.58	352.42	342.37	365.46	405.90
Mizoram	95.47	95.23	99.18	96.76	102.12	104.38	111.57	114.40
Nagaland	142.07	148.77	133.77	138.05	139.00	133.50	135.04	156.55
Tripura	296.01	359.46	269.32	312.39	258.54	278.62	239.53	225.23

Deliberation of the sub-Committee:

Member Secretary, NERPC stated that the disparities in actual vs LGBR should be taken into account while submitting the LGBR data for 2019-20.

The Sub-committee noted as above.

Action: All SLDCs.

B.2. OPERATIONAL PERFORMANCE AND GRID DISCIPLINE DURING JANUARY, 2019

As per the data made available by NERLDC, the grid performance parameters for January, 2019 are given below:

NER PERFORMANCE DURING JANUARY, 2019

States	Energy Met (MU)		w.r.t. Dec,18 % inc (+) /dec (-)	Energy Reqr. (MU)		w.r.t. Dec,18 % inc (+) /dec (-)	% inc (+) /dec (-) of energy reqr vs met. In Jan,19
	Jan-19	Dec-18		Jan-19	Dec-18		
Ar. Pradesh	68.24	66.39	2.79	68.59	66.92	2.50	-0.51
Assam	711.61	717.65	-0.84	720.73	731.54	-1.48	-1.27
Manipur	85.75	82.72	3.66	86.24	83.20	3.65	-0.57
Meghalaya	198.64	194.31	2.23	198.64	194.31	2.23	0.00
Mizoram	54.55	61.52	-11.33	55.05	61.82	-10.95	-0.91
Nagaland	64.14	64.05	0.14	72.48	72.39	0.12	-11.51
Tripura	115.91	111.63	3.83	116.00	111.84	3.72	-0.08
Region	1298.85	1298.27	0.04	1317.74	1322.02	-0.32	-1.43

States	Demand Met (MW)		w.r.t. Dec,18 % inc (+) /dec (-)	Demand in (MW)		w.r.t. Dec,18 % inc (+) /dec (-)	% inc (+) /dec (-) of energy reqr vs met. In Jan,19
	Jan-19	Dec-18		Jan-19	Dec-18		
Ar. Pradesh	124	131	-5.34	138	138	0.00	-10.14
Assam	1468	1418	3.53	1491	1440	3.54	-1.54
Manipur	216	211	2.37	219	214	2.34	-1.37
Meghalaya	372	366	1.64	372	365	1.92	0.00
Mizoram	119	111	7.21	121	112	8.04	-1.65
Nagaland	138	133	3.76	140	135	3.70	-1.43
Tripura	223	228	-2.19	224	240	-6.67	-0.45
Region	2552	2511	1.63	2575	2541	1.34	-0.89

**REGIONAL GENERATION & INTER-REGIONAL
EXCHANGE IN MU**

Month---->	Jan-19	Dec-18
Total Generation in NER (Gross)	1337.745	1342.003
Total Central Sector Generation (Gross)	1048.299	1016.068
Total State Sector Generation (Gross)	289.446	325.935
Inter-Regional Energy Exchange		
(a) NER-ER	372.13	246.21
(b) ER-NER	1.15	99.54
(c)NER-NR	0.00	76.18
(d)NR-NER	433.45	275.56
© Net Import	62.47	52.71

AVERAGE FREQUENCY (Hz)

Month---->	Jan-19	Dec-18
	% of Time	% of Time
Below 49.9 Hz	10.69	12.60
Between 49.9 to 50.05 Hz	70.25	76.96
Above 50.05 Hz	19.06	10.43
Average	49.99	49.98
Maximum	50.28	50.25
Minimum	49.58	49.67

Deliberation of the sub-Committee:

NERLDC gave a presentation on the grid performance for the month of January'19 (**Annexure-B.2-a**). NERLDC also highlighted that Daily, Weekly and Monthly Voltage Deviation Report, Frequency Deviation Report and System Reliability Report for January'19 was already mailed to all the constituents for necessary actions. Further, it was informed that members may access these reports from NERLDC website under the tab CERC KPI Reports. NERLDC informed the forum about the number of lines kept open on high voltage. NERLDC again requested for early restoration of reactors which are under long outage and commissioning of new reactors at the earliest as mentioned in Sl. No. B.1.2 and C.1 and support from Generator to control voltage so that it does not require to open lines for maintaining voltage profile within IEGC band. NERLDC informed that presently Arunachal Pradesh has power allocation from Unchahar STPP(7.14%) w.e.f. 01.02.19 and from Myntrah Wind Power(128.7 MW w.e.f. 30.01.19) in addition to normal allocation from ER&NER.

The Sub-Committee noted as above.

ITEMS FOR DISCUSSION

C. OLD ITEMS

1. Status of Generating Units, Transmission Lines in NER:

During 153rd OCC meeting, the status as informed by different beneficiaries is as follows:

SN	Items	Status as given in 152 nd OCC Meeting		Status as given in 153 rd OCC Meeting	
		Timeline for completion	Furnishing of detail parameters	Timeline for completion	Furnishing of detail parameters
a. New Elements					
1	400/220kV, 315 MVA ICT-1 of NTPC at Bongaigaon	By Mar'19	To be submitted to NERLDC.	By Mar'19	To be submitted to NERLDC.
2	Kameng HEP of NEEPCO two units (2 x 150 MW) Next two units (2x150 MW)	To be reviewed	Already submitted.	By Mar'19	Already submitted.
3	132kV Monarchak – Surjamaninagar D/C of TSECL	by Jun'19	To be submitted to NERLDC.	by Jun'19	To be submitted to NERLDC.
4	400/220 kV 315 MVA ICT-II at Bongaigaon	LV side (GIS) is expected to be completed by Mar'19.	LV side separate application to be submitted	LV side (GIS) is expected to be completed by Mar'19.	LV side separate application to be submitted
5	220/132 kV, 160MVA ICT-II at Balipara	Not allowed for transit by WB Govt. to factory. Uncertain date.	To be submitted to NERLDC.	Not allowed for transit by WB Govt. to factory. Uncertain date.	To be submitted to NERLDC.
6	220/132 kV, 1x160 MVA ICT with GIS Bay at Kopili	Expected to be completed by Mar'19	To be submitted to NERLDC.	Expected to be completed by Mar'19	To be submitted to NERLDC.

7	33kV bay at 220kV Mariani(AS) S/Sn	PG to pay by Jan'19	Not applicable.	Payment done. APDCL to expedite.	Not applicable.
8	33kV bay for 132kV Badarpur(PG) S/Sn	To be expedited by APDCL.	Not applicable.	To be expedited by APDCL.	Not applicable.
9	Dedicated 33kV feeder at Khliehriat Substation from Lumshnong.	To be taken up with MePDCL. SLDC to kindly mediate.	Not applicable.	To be taken up with MePDCL. SLDC to kindly mediate.	Not applicable.
10	Replacement of 2x315 MVA ICTs with 2x500 MVA ICTs at Misa (PG)	ICT-I expected by May'19 and ICT-II by Jun'19	To be submitted to NERLDC.	<ul style="list-style-type: none"> • ICT-I Expected by March'19 without Tertiary connectivity of 4X25MVAR Tertiary Reactors and • ICT-II Expected by Jun'19 	To be submitted to NERLDC.
11	400kV Transfer Bus at BgTPP	By 21.01.19	Not applicable.	completed	Not applicable.
b. Elements under breakdown/upgradation					
12	Up-gradation of 132 kV Lumshnong-Panchgram line	DPR sent to NLDC/NPC	Not applicable.	DPR sent to NLDC/NPC	Not applicable.
13	Switchable line Reactors at 400 kV Balipara & Bongaigoan Ckt # 1 & 2	Balipara : CSD tuned for Ckt-1 S/D applied for Ckt-II on 04.02.19 Bongaigaon: Completed	Not applicable	Completed in all aspects	Not applicable
14	PLCC Panels at Loktak end of Loktak - Ningthoukhong 132 kV feeder and Loktak - Rengpang 132 kV feeder	Panels not supplied at Loktak end. NERPC to write to MD, MSPCL to expedite.	Not applicable.	Panels not supplied at Loktak end. NERPC to write to MD, MSPCL to expedite.	Not applicable.
15	Upgradation of 132 kV Silchar-Imphal to 400 kV	Ckt#II-upgraded on 25.12.18 Ckt#I: By Jan'19	To be submitted to NERLDC	Completed for both circuits	submitted to NERLDC. Issue may be dropped

16	Replacement of CTs and installation of Bus Bar Protection at 220 kV Misa	Expected Completion : Mar'19	Not applicable	Expected Completion : Mar'19	Not applicable
17	Upgradation of 132 kV Bus Bar at Umiam Stg-III to ACSR Zebra	DPR will be submitted soon.	Not applicable	DPR will be submitted soon.	Not applicable
18	Integration of existing bays with C264 RTU at RHEP by NEEPCO	By Jan'19	Not applicable	Completed on 06.02.2019	Not applicable
19	220/132 kV 30 MVA ICT at Mokochung	Mar'19(LOA date) to be reviewed later on.	To be submitted to NERLDC	Mar'19(LOA date) to be reviewed later on.	To be submitted to NERLDC
20	Upgradation of 400kV Silchar-Imphal Ckt#I	By Jan'19	Already submitted to NERLDC	Completed. to be dropped.	Already submitted to NERLDC

The Sub-Committee noted as above.

Action: All state utilities/central utilities/NERPC.

D. NEW ITEMS

D.1 Generation Planning (ongoing and planned outages)

NEEPCO/NHPC may kindly intimate the availability for hydro stations:

- a. Present per day MU and projected number of days of operation.

Plants	Reservoirs level in meter as on 13-02-19	MU content	Present DC (in MU)	No of days as per current generation
Khandong + Kopili stg II	712.45	74.00	0.198	
Kopili	599.74	74.00	1.104	
Doyang	308.12	34.5	0.15275	
Loktak	768.31	34	1.097	

Thus, for maintaining the generation availability of NER Region it is requested to all hydro generations to judiciously plan the utilization of water and furnish the day ahead declared MU such that NER Region does not face lack of generation availability in the upcoming lean hydro season.

The outage of other generating stations may be approved considering the present water levels in reservoirs.

Deliberation in the Meeting:

The forum felt that in view of large number of shutdown underway for Hydel power stations requested all thermal stations to defer approved shutdown/forced outage till such time, when RHEP is returned to service.

The forum approved the shutdown of Kopili Unit #II w.e.f. 19.02.19 to 09.03.19 and Kopili Unit #I w.e.f. 11.03.19 to 31.03.19.

The Committee discussed and approved the proposed shutdown by Generating Stations and the same has already been uploaded in the website of NERPC.

Action: All generating utilities/NERLDC.

D.2 Outage Planning Transmission elements

It was agreed in the 99th OCC meeting that shutdown will be availed only after approval is given by the OCC forum. It was also agreed that deferment/revision of outages elements other than already approved in OCC will be henceforth put/displayed in the website of NERPC (**under Operational Activities/OCC Approved shutdown**) as per CERC regulations/ CEA guidelines etc for ensuring smooth & secure grid operation.

Furnishing request of shut down of the element, which was approved by NERPC, by Indenting Agency (ISTS licensees/STUs/Generating Companies) to NERLDC:

Planned shutdown approved by NERPC shall be considered for implementation by NERLDC on D-3 basis. If an outage is to be availed on say 10th of the month, the shutdown availing agency would reconfirm to NERLDC on 7th of the month by 10:00 Hr. This practice is necessary to ensure optimal capacity utilization and the time required for associated system study/coordination by/amongst RLDC/NLDC.

In 134th OCCM, it was decided that all communication related shutdown be approved in OCC forum only.

In 142nd OCCM, Director (O&P), NERPC suggested that henceforth shutdown list may be prepared under following categories:

- (i) New Construction Related Shut Down
- (ii) Existing System Improvement Related Shut Down.
- (iii) Existing System Normal Maintenance Related Shut Down
- (iv) Communication Related Shutdown
- (v) R&U works Related Shut Down under PSDF

The forum further decided that the modalities of communication related shutdown should be finalized. Members requested NERPC to invite POWERGRID telecom in next OCCM alongwith with officials (handling communication issues) from all utilities for this purpose.

Deliberation in the Meeting:

NERLDC highlighted that OCC forum approves the S/D after lots of discussion but it is observed that some of the shutdowns are not being availed. Details of Shutdown not availed and shutdowns applied on D-3 basis is as below:

Total S/D approved	Total S/D availed	Total S/D not availed	Total S/D availed on D-3 basis	Total S/D not applied on D-3 basis
136	86	50	61	25

It was decided that transmission utilities are requested to give copy of the mail for shutdown application on D-3 basis to all the SLDCs in addition to NERLDC.

NERLDC highlighted that the inordinate delay in revival of elements under S/D for ISTS licensees is coming very high which is affecting the secure operation of the grid.

Details for the month of December, 2018 are as below:

Transmission Licensee	Total Delay	Avg. Delay	Max. Delay
POWERGRID	332:52	04:41:18	95:44
NETC	00:28	00:14	00:28
ENICL	-	-	-

NERLDC requested the forum to restrict the number of non-occ approved shutdown to 5-10%. Forum requested that details of non-occ approved shutdown under construction/PSDF related works may be separately categorized for more clarity.

Regarding non-availing of approved Shut Down, Sr. GM (AM), NERTS requested NERLDC to segregate the shut downs under different category mentioned above. This is pertinent as in many cases of Construction Related approved shut downs the same cannot be availed due to last minute development of ROW issue. Further, the cause of non-availing of approved shut down may please be recorded on real time basis for necessary corrective measures, if any.

Regarding delay in returning Shut Down, Sr. GM (AM), NERTS requested NERLDC to furnish the delay element-wise with cause to be recorded on real time basis. This will help to analyze delay for further corrective measures, if any.

The sub-Committee discussed and approved the proposals received from the constituents regarding transmission elements and generating units for February, 2019-March, 2019 and the same has already been uploaded in website of NERPC.

D.3 Estimated Transmission Availability Certificate (TAC) for the month of October, 2018 to December, 2018:

NETC and POWERGRID have submitted the outage data for the month of October 2018 - December, 2018. So the attributability of outage of the said elements may please be finalized.

NERTS has informed that in order to process the monthly energy billing in time, it is desirable that within 30(thirty) days availability certificate is issued. It is to be deliberated how to issue the availability certificate within 30(thirty) days.

Deliberation in the Meeting:

NERLDC requested NETC & NERTS to submit the data to NERLDC by 5th of the month, so that verification can be completed within 15 days after submission of documents/data as per procedures.

The Sub-Committee noted as above.

Action: Concerned transmission utilities/NERLDC/NERPC

D.4. Update on Real Time Energy Assessment for Effective Grid Management:

NERLDC has provided public IP of its server.

b) Following list of location for meters replacement / installation were submitted for the CDAC project:

SI. No	Feeder's Name	Status	Meter to be replaced/Installed by PGCIL
1	Srikona End of 132kV Silchar FDR-1	Replace	1
2	Srikona End of 132kV Silchar FDR-2	Replace	1
3	Deomali End of 220kV Kathalhuri Fdr	Replace	1
4	PK Bari-I End of 132kV Silchar-1	Replace	1
5	PK Bari-I End of 132kV Silchar-2	Replace	1
6	Pavoi End of 132kV BNC-1	Replace	1
7	Mokok (S) End of Doyang	Replace	1
8	Mokok (S) End of Mokok-Mokok-1	Replace	1
9	Mokok (S) End of Mokok-Mokok-2	Replace	1
10	Khupi End of 132kV Balipara	Install	1
11	Lekhi End of 132kV Pare	Install	1
12	Khupi End of 132kV Kameng	Install	1
13	Zuangtui End of Melriat	Install	1
14	Luangmual End of Aizawl	Install	1

In 151st OCC meeting M/s CDAC informed the following:

- SRS, SAT has been approved.
- Beta version of software REALver1.0 has been installed at NERLDC.
- 8 locations of Assam meter data is reporting including one proprietary L&T meter at Azara. Reporting interval is 15min.
- Last 35 days data is being stored.
- 8 hardware servers have been delivered and 120 TARA devices has also been delivered.
- 79 location TARA remaining to be installed. The schedule of completion against each control area/states was finalised with overall target being Jan'19.
- The cables required in the respective sub-stations for connecting meter to the TARA devices shall be provided by the concerned utilities.

The forum decided that the following shall be the nodal officer for installation of TARA devices and configuration of software at SLDC premises:

1. Sh. D. Kamduk, SLDC, DoP Ar. Pradesh
2. Smt L. Ritu, SLDC, MSPCL
3. Sh. D. Das, SLDC, AEGCL
4. Sh. A. Koch, SLDC, MeECL
5. Sh. B. Tlumtea, SLDC, DoP Mizoram

6. Sh. R. Iralu, SLDC, DoP Nagaland

7. Sh. M. Paul, SLDC, TSECL

Deliberation in the meeting

Director, NERPC regretted the absence of CDAC representative in the 153rd OCCM.

AGM, SLDC, AEGCL informed that at present REAL project is giving the average drawal in the last 15min time block. This is having little utility w.r.t. grid operation under the present regime of DSM(4th amendment).

Sr. Manager, SLDC, Tripura stated the following:

- Though server has been installed at SLDC, HMI software has not been installed on the same.
- Data is being accessed by SLDC through web access.
- Majority of TARA devices are not reporting.
- OA consumers provision is absent.

After detailed deliberation, it was decided that a Special Meeting would be convened to resolve the issues pertaining to REAL/TARA, SCADA & Communicatio.

The Sub-Committee noted as above.

Action: All utilities/NERPC.

D.5. Ensuring proper functioning of Under Frequency Relays(UFR) & df/dt Relays:

In 7th NPC meeting held on 08.09.17 it was agreed that mock test is good enough to test the healthiness of the UFR & df/dt relays. The frequency of site inspection was proposed to be upto six months. RPC may carry out periodic inspection, in line with provisions of IEGC and furnish inspection reports to NPC.

Discussions as per previous meetings:-

- Inspection for Mawphlang completed.
- Inspection for Baghjap, Sankardevnagar and Sipajhar under Assam would be tentatively done in the first week of January 2019.

Deliberation in the meeting

Director (O&P), NERPC informed for the Assam stations as above UFR inspection is envisaged to be done on first week of March, 2019. He requested the support of AEGCL, NERTS and NERLDC for the same.

The Sub-Committee noted as above.

Action: NERPC/NERTS/NERLDC/AEGCL.

D.6. Extended C Band VSAT for power system communications in NER:

As per discussion in 10th NETeST meeting it was decided that VSAT for remote station connectivity would be explored. NERTS was requested to prepare DPR and present in 147th OCC.

In 151st OCCM Members of the group which visited Bangalore on 10.12.18 updated the forum of the technical aspects of the visit:

- Extended C Band Technology is being used by KPTCL. Same technology has to be replicated for NER.
- Minimum hardware is required at the remote stations and easy to install with only 3 units (modem, switch and antenna).
- Delay in receipt of data & voice is minimum and negligible.
- Voice communication is reliable and clear.

The team has confirmed that they are convinced about the performance of VSAT Communication Technology and that it is more suitable for NER Region.

The forum thanked the members for undertaking this visit and agreed to the implementation of Pilot Project. The forum requested the members for finalizing the modalities for implementation of pilot project. Members took cognizance of the view and referred the matter to the next NETeST meeting of NERPC for further discussion.

In 152nd OCCM Director, NERPC informed that the financial impact for NER states i.r.o. VSAT for Roing, Tezu, Namsai by POWERGRID is to be explored (tentative cost is • 54,653,880.00 for 5 years).

Further, he apprised the forum of the deliberations of the 12th NETeST meeting on 10.01.19 regarding pilot project of VSAT at Byrnihat. The tentative cost of • 5 lakhs is to be shared amongst all utilities. Members agreed in-principle for Pilot Project of VSAT for NER and requested NERPC to write to concerned authorities detailing the tentative cost etc.

Deliberation in the meeting

Sr.GM, NERTS informed that for cost breakup of VSAT for 3 locations, the matter has been referred to Corporate LD&C. Director, NERPC informed that the pilot project cost breakup amongst all the utilities would be put up for approval of TCC/RPC. The forum concurred.

The Sub-Committee noted as above.

Action: NERTS/NERLDC/NERPC.

D.7. DIMAPUR_PG Voice communication and telemetry out since Feb'18.

In 148th OCCM DGM(AM), NERTS informed that Dimapur substation phone is working OK since March'18 (VOIP number 23640213). The same was restored along with power system restoration. Under urgency in March18, NERTS had collected one telephone from SLDC end and same was later replenished. For data, he informed that the same would be corrected by Nov'18.

In 151st OCCM NERTS informed that Dimapur voice communication has been restored and data would be restored by Feb'19.

Deliberation in the meeting

NERTS informed that voice communication already restored. Restoration of Telemetry Data is expected by Mar'19.

The Sub-Committee noted as above.

Action: NERTS

D.8 Update on PDMS:

The following were decided as per deliberation in the previous meeting(s):-

- All utilities to inform the name and details of SPOC (Single Point of Contact).
- Assam would be the Pilot state.
- M/s PRDC would organise a training program on PSCT tentatively on the first week of December, 2018. AEGC/ APDCL would host the same.

In 151st OCCM PRDC representative informed the following status:

- Data has been collected from 30 locations of Assam.
- For 12 out of 30 locations relay setting has been obtained.
- Network modelling in PSCT has been initiated.
- Server is to be installed. In the interim data would be backed in PC based Server.
- Operational load flow date may be fixed.

After detailed deliberation it was decided that the date for operational load flow would be 19.12.2018(at 19:00 hrs). The forum requested all the utilities to submit the following data:

- MW and MVAR flows for all station incomers and outgoing lines, transformers, reactors, cap banks and load points till 132 kV or 66 kV. SCADA snapshot for that particular time stamp from NERLDC and state wise SLDCs.

- Voltage at all buses or nodes.
- Transformer tap positions.

It was decided that PRDC along with the help of NERPC & NERLDC would circulate formats to the respective utilities by 17.12.18.

M/s PRDC has submitted the Operational Load Flow vide letter dated. 24/01/19 is attached at **Annexure-D.8**

Deliberation in the meeting

Director, NERPC requested the utilities to submit their comments i.r.o. Operational Load Flow at the earliest. He also informed that the database building and network modeling for Assam System has been completed and physical server installation at NERPC is about to start.

The Sub-Committee noted as above.

Action: All utilities.

D.9 Non Reporting of RTU at RHEP:

In 151st OCCM NEEPCO informed the following status:

- Bays to be shifted on C264 by Dec'18
- Data to be extended upto nearest broadband i.e. BNC by Dec'18

In 152nd OCCM NEEPCO informed that shifting on C264 would be completed by Jan'19. NERTS informed that wideband would be extended upto RHEP through OPGW latest by Mar'19

Deliberation in the meeting

Sr. Manager, NEEPCO informed that works related to transition to C264 has been completed and RHEP RTU is reporting w.e.f. 06.02.19. Members unanimously congratulated NEEPCO for the completion of the long awaited works and hoped that in future also NEEPCO would adhere to such deadlines.

Regarding Wideband upto RHEP, the forum decided that the matter may be pursued in NETeST forum.

The forum decided to drop the agenda item.

The Sub-Committee noted as above.

Action: NERTS

D.10 Utilization Certificate for Deposit Work of Construction of 33kV Transmission Line and Associated Bay from 220kV Mariani S/S(ASEB) to 220kV New Mariani S/S of POWERGRID

An amount of Rs.100,34,749.00 was deposited to ASEB (vide DD N.o. 059528 Dated 04.08.2015 of Rs.7,81,032.00 + DD No. 914008 Dated 06.01.2014 for Rs.92,53,717.00 both Axis Bank) for the deposit work. As on date POWERGRID have received provisional utilization of Rs.59, 34,884.00 as detailed below:

- i) Rs. 45, 47,620.00 from DGM, APDCL.
- ii) Rs.13, 87,264.00 from AGM, 22kV Gid S/S AEGCL.

Balance utilization to be Received: Rs.40, 99,865.00

The above work has been completed long back, but final utilization certificate has not been issued till date inspite of repeated requests by POWERGRID. ASEB to resolve the issue at the earliest for issue of final utilization certificate.

In 150th OCCM APDCL was requested to issue the utilization certificate at the earliest. In 151st OCCM GM(AM), NERTS informed that APDCL has submitted the utilization certificate but AEGCL has yet to submit. The forum requested AEGCL to expedite.

Deliberation in the meeting:

AEGCL informed that UC has been submitted to PGCIL subject to verification.

The Sub-Committee noted as above.

Action: AEGCL.

D.11. Submission of the Annual Load Generation Balance Report (LGBR) for Peak as well as Off-peak scenarios and the Annual outage plan for 2019-20 by 31.12.18 as per IEGC

As per IEGC, each SLDC shall submit LGBR for its control area, for peak as well as off-peak scenario, **by 31st December for the next financial year**, to respective RPC Secretariat. The annual plans for managing deficits/surpluses in respective control areas shall clearly be indicated in the LGBR submitted by SLDCs.

As per IEGC, all SEBs/STUs, Transmission Licensees, CTU, ISGS, IPPs, MPPs and other generating stations shall provide to the respective RPC Secretariat their proposed outage plan in writing for **the next financial year by 31st October of each year**. These shall contain identification of each generating unit/transmission line/ICT etc., the preferred date for each outage and its duration and where there is flexibility, the earliest start date and latest finishing date.

Deliberation in the meeting:

Director, NERPC stated that the LGBR for 19-20 would be completed by 28.02.19.

The Sub-Committee noted as above.

Action: NERPC.

D.12 Full schedule for PG Test:

It is required to conduct PG test of C&I system of our plant NTPC BgTPP. Full schedule is required for atleast 12 hours per day for 2 to 3 days in order to conduct the PG Test.

The 152nd OCC forum decided that during RHEP plant shutdown 01.02.2019 onwards, the PG test may be done. However coal stock is to be ensured by BgTPP five(5) days in advance before the commencement of PG test.

Deliberation in the meeting:

AGM, NTPC informed that the PG test of C&I system was completed in 2hrs. The full schedule for 12hours per day for 2 to 3days was not required. The forum noted and advised NTPC-BgTPP to inform in advance before commencement of any such testing activities and to intimate to NERLDC on real time.

The Sub-Committee noted as above.

D.13 Non-availability/ Non-functioning of synchronization facility at the following stations

- | | |
|-------------------|-------------------------|
| a) Kumarghat (PG) | d) Itanagar/Chimpu (AP) |
| b) Mariani (AS) | e) Nirjuli (PG) |
| c) Lekhi (AP) | f) Gohpur (AS) |

In 152nd OCC meeting NERTS informed that synchronization facility is available at RTAMC for the POWERGRID stations. After detailed deliberation, it was decided that utilities should identify the 132 kV and above voltage level stations where synchronization facility is not available by Jan'19 and take necessary actions to procure synchronization facility.

Deliberation in the meeting:

AEGCL informed that sync check is not available for 132kV Mariani(AS), Gohpur, Rangia, Agia and other 132kV stations. Procurement of synchronizing trolley and

associated equipments(sockets etc.) is being taken up and same is expected to be completed by 6 months. DoP Ar.Pradesh informed that the sync check facility is not available at Lekhi and Chimpu, and would be in place by Sep'19.

TSECL & AGTCCPP expressed the concerns on non-synchronization of 132 kV AGTCCPP – Kumarghat line at Kumarghat by NERTS. Forum requested NERTS to check the same and intimate the details in the next OCCM. It was decided that Kumarghat sync check would be tested on 16.02.19.

The Sub-Committee noted as above.

Action: NERTS, AEGCL, DoP Ar. Pradesh.

D.14 Compliance of CERC Order:

Against compliance of CERC Order dated 14.06.2016(Non-compliance of Commission's direction dated 26.9.2012 in Petition No. 168/MP/2011) in Petition No.09 & 10/SM/2014 Commission directed RPCs Secretariat to examine the cases of delayed clearance of faults on the transmission system during last two years in respective Region and submit an analysis report within six month from the date of issue of order.

Deliberation in the meeting:

The forum requested NERLDC to compile the cases of delayed clearance of faults on the transmission system for 2016-17 and 2017-18. NERLDC agreed and promised that the report would be compiled latest within two months.

The Sub-Committee noted as above.

Action: NERLDC.

D.15 Signing of TSA for NERSS-IX:

Scope of NERSS-IX:

- 132kV Pare-N.Lakhimpur D/C (with ACSR Zebra conductor) alongwith 2 nos 132kV Line bays at N.Lakhimpur End.
- LILO of one circuit of 132kV Pare-N.Lakhimpur D/C line at Nirjuli S/S.

Till date NER constituents have not signed the TSA.

Letter from PFC in this regard is attached at **Annex D.15**

Deliberation in the meeting:

Director, NERPC requested all the transmission utilities to sign the TSA for NERSS-IX at the earliest.

The Sub-Committee noted as above.

Action: all STUs.

D.16 Phase shift errors in PMU:

In 12th NETeST meeting it was decided that physical (primary) matching of phases to be done, wherever anomaly is present. To figure out the detailed action plan and schedule the matter was referred to Sub-group of PCC.

In Sub-group meeting on 17.01.19 NERLDC informed that the following PMUs are having phase shift errors:

- Kopili
- Misa
- Samaguri
- Tinsukia
- Mariani(AS)
- Silchar

Sr. DGM, NERTS informed that the matter had been discussed previously, the gist of which is:

1. Misa ICT primary/secondary not matching
2. Agia/BTPS has to be matched with Sarusajai and Samaguri
3. For this AEGCL has to change connections from dead end tower to gantry at identified locations.

Deliberation in the meeting:

Sr.GM, NERTS informed that the 220kV of NER has phase matching with 220kV ER(Birpara). So, at present it is not recommended to change at primary as downstream will be affected. After detailed deliberations, the forum decided that wirings in the secondary may be changed. In this regard, a matrix is to be made for changing the connections. Since PMU is not installed in all ISTS elements, concerned utilities are requested to trigger DR output manually for all ISTS elements and submitted to NERPC/NERLDC for preparation of the matrix. It was decided that a team from NERPC (Sh Srijit Mukherjee), NERTS (Sh. Supriya Paul/Devaprasad Paul), NERLDC (Sh. Zerin Jacob) & AEGCL (Sh. Abhishek Kalita) will identify the exact problem at Silchar, Misa & Sarusajai by Feb'19.

The Sub-Committee noted as above.

Action: NERTS, AEGCL, NERLDC & NERPC.

D.17 Compliance of CPCB directions under Section-5 of Environmental Protection Act, 1986 for BgTPP:

NTPC vide letter dated. 19.01.2019(details attached at **Annex.D.17**) has intimated the following:

- FGD plant was already awarded and under installation at Bongaigaon, so it was not included in the Phasing plan prepared by CEA.
- Construction of FGD plant not completed within stipulated time due to various project implementation issues.
- A unit wise phasing plan for FGD implementation has been made and the tentative shutdown schedule is given below:

Unit-I	December, 2021
Unit-II	September,2022
Unit-III	December,2022

Deliberation in the meeting:

AGM, NTPC informed that alongwith the tentative shutdown schedule given above, APM would be combined. The forum approved and recommended for CEA approval.

The Sub-Committee noted as above.

Action: NERPC, NTPC.

D.18 Compensation for Heat Rate degradation and Auxiliary Energy Consumption

With reference to clause 3 of regulation 6.3(B), Where the CGS or ISGS, whose tariff is either determined or adopted by the Commission, is directed by the concerned RLDC to operate below normative plant availability factor but at or above technical minimum, the CGS or ISGS may be compensated depending on the average unit loading duly taking into account the forced outages,planned outages,PLF, generation at generator terminal, energy sent out ex-bus, number of start-stop, secondary fuel oil consumption and auxiliary energy consumption, in due consideration of actual and normative operating parameters of station heat rate, auxiliary energy consumption and secondary fuel oil consumption etc. on monthly basis duly supported by relevant data verified by RLDC or SLDC, as the case may be.

Proviso (vi) of clause 3 of regulation 6.3 (B) says that "The compensation so computed shall be borne by the entity who has caused the plant to be operated at schedule

lower than corresponding to Normative Plant Availability Factor up to technical minimum based on the compensation mechanism finalized by the RPCs.

Right now we are submitting the RSD Annexure as per RSD mechanism for reserve S/D on monthly bases (RSD data sheet is attached for reference), NERPC may give compensation mechanism for compensation for Heat Rate degradation and Auxiliary

Energy Consumption depending on the average unit loading duly taking into account the forced outages, planned outages, PLF, generation at generator terminal, energy sent out ex-bus, number of start-stop, secondary fuel oil consumption and auxiliary energy consumption, in due consideration of actual and normative operating parameters of station heat rate, auxiliary energy consumption and secondary fuel oil consumption etc. to operate below normative plant availability factor but at or above technical minimum.

Deliberation in the meeting:

After detailed deliberation, it was decided that a Special Meeting would be convened prior to the 154th OCC to discuss the Heat Rate Degradation and Compensation Calculation for Thermal Power Plants.

The Sub-Committee noted as above.

Action: NERPC.

D.19 DSM Data Sheet Calculation as per DSM 4th Amendment

DSM 4th Amendment is applicable wef 1st Jan 2019, DSM Data sheet calculation understanding is required for reconciliation, also un cleared issues need to be addressed, like no under injection below 49.85 Hz and no over injection on or above 50.05 Hz but in case of sign change is mandatory below 49.85 Hz or above 50.05 Hz which clause will supersede etc.

Deliberation in the meeting:

Director, NERPC informed that Data Sheet for DSM would be made available in website of NERPC shortly. Regarding difficulties in implementation OTPC was requested to submit in writing to NERPC ASAP.

The Sub-Committee noted as above.

Action: NERPC/OTPC.

D.20 Transfer of ownership of two 220kV bays at Mariani GSS of AEGCL from PGCIL to AEGCL:

Consequent upon the LILO connection of 400kv (charged at 220kv) Missa line & 220kv Kathalguri line at PGCIL's New Mariani S/S, the present connection of AEGCL's 220kv Mariani SIS with these two lines will cease to exist. This will render five nos. of double circuit towers (designed for 400kv) of PGCIL redundant. AEGCL intends to utilize these towers for connecting its Mariani GSS with New Mariani GSS of PGCIL to reinforce the reliability and security of 220kv system at our Mariani GSS. The 18th TCC & 18th NERPC Meeting on 10th & 11th October, 2017, deliberated on this issue and necessary approval was accorded for utilization of the five redundant towers by AEGCL. However, the two 220kv bays at Mariani GSS of AEGCL (presently utilized for Missa & Kathalguri connection) will also become redundant. These bays are currently owned and maintained by PGCIL. AEGCL, therefore, intends to utilize these two bays for connection of the proposed double circuit link from Mariani (AEGCL) to New Mariani (PGCIL). The modus operandi for such an utilization of these towers may be sorted out through discussion and on mutually agreeable terms between AEGCL and PGCIL

Deliberation in the meeting:

Sr.GM, NERTS informed that during 18th NERPC Meeting, POWERGRID agreed in-principle to allow utilization of 5 nos. of 400kV towers of PGCIL by AEGCL which will become redundant upon shifting of existing 220KV LILO of Misa – Kathalguri line from 220/132kV Mariani (AEGCL) SS to 220kV Mariani (PGCIL) SS which will be upgraded to 400KV Station under NERSS-VI Scheme as approved in 5th SCM and 15th NERPC Meeting. POWERGRID further stated that financial implications if any as per CERC direction will have to be borne by AEGCL and Assam agreed. Thereafter, TCC & NERPC approved the decision.

In similar line, he suggested that utilization of two nos. of 220kV bays of POWERGRID at Mariani (AEGCL) by AEGCL upon implementation of NERSS – VI Scheme may be regularized in next TCC/RPC Meeting. Forum agreed and requested NERPC to put up in next TCC/RPC Meetings.

The Sub-Committee noted as above.

Action: NERPC/OTPC.

D.21 Design & implementation of SPS for Outage of 400 kV Bus

400 kV Bus — I & II at Silchar (PG) and Outage of any one circuit of 400 kV Bongaigaon — BgTPP D/C

Deliberation in the meeting:

CGM, NERLDC clarified that upon System Study by NERLDC the above SPS has been proposed. After detailed deliberation, it was decided that the matter would be discussed in System Study Meeting separately. NERPC informed that System Study Meeting would be scheduled in the 1st week of Mar'19.

The Sub-Committee noted as above.

Actions: All concerned utilities/NERPC

D.22 Schedule for special meeting on review of existing SPSs & devising new SPSs as per present requirement of NER grid

Deliberation in the meeting:

After detailed deliberation, it was decided that the matter would be discussed in System Study Meeting separately.

The Sub-Committee noted as above.

Actions: All concerned utilities

D.23 Operation of RHEP units in Synchronous condenser mode

Deliberation in the meeting:

Sr. Manager, NEEPCO informed that prima-facie it appears that Synchronous Condenser mode operation is not possible. However NEEPCO has written to BHEL(Bhopal) for solution. This item would be reviewed in the next meeting.

The Sub-Committee noted as above.

Actions: NEEPCO.

D.24 Joint validation of SCADA data by NERTS & NERLDC

Deliberation in the meeting:

CGM, NERLDC informed that the data validation has been partially completed. He requested active participation from NERTS so that the same may be completed by Feb'19.

The Sub-Committee noted as above.

Actions: NERTS, NERLDC

D.25 Development of Consolidated communication path map for NER

Deliberation in the meeting:

NERLDC informed that Assam, Meghalaya map has been validated. For other state(s) the following status:

- Tripura - Submitted
- Ar. Pradesh - Being prepared
- Nagaland - Data to be submitted
- Mizoram - Data to be submitted

The forum decided that the item is to be monitored in detail in the NETeST forum.

The Sub-Committee noted as above.

Actions: NERLDC

D.26 Organizing PCC Meeting on Bi-Monthly Basis

Deliberation in the meeting:

Member Secretary once again reiterated that the PCC meetings were previously held on monthly basis. However, due to below par attendance from the member utilities, it is being convened on a quarterly basis. CGM, NERLDC persuaded that the meeting be held monthly. Sr. Manager, TSECL stated that presently R&U works are going on in full swing. For this all the protection engineers are busy and it is difficult to depute personnel for monthly Sub-group/PCC meetings. EE, System Protection MePTCL agreed with the opinion of TSECL.

Director, NERPC concluded that at present due to severe paucity of officials due to R&U works, it would not be possible to convene PCC meetings monthly. This item will be reviewed after Jun'19. However Sub-group meetings would be convened at the minimum frequency of once a month and senior officials from NERPC, NERTS, NERLDC would attend this meeting. Agenda of subgroup meeting will be circulated 5 days in advance to all concerned utilities by NERPC.

The Sub-Committee noted as above.

D.27 Commissioning of 400 kV Transfer Bus at BgTPP

Deliberation in the meeting:

NTPC informed that as on date the 400kV Transfer Bus at BgTPP will be in-service by Feb'19.

The Sub-Committee noted as above.

D.28 Availing opportunity shutdown of 132kV Salakati-Gelephu:

Availing opportunity shutdown of Salakati - Gelephu 132 kV line on 22.01.19 without prior intimation to NERLDC by NERTS

Deliberation in the meeting:

NERTS informed that new personnel has been posted in the Salakati station. Being unaware of the protocols, he availed shutdown without prior intimation. The same would not recur. NERLDC requested all constituents to take prior permission for availing any opportunity shutdown.

The Sub-Committee noted as above.

Action: NERTS

D.29 Attending rectification work of synchronizing circuit of Misa-1 Tie bay at Balipara

Attending rectification work of synchronizing circuit of Misa-1 Tie bay at Balipara on 15.01.19 without prior intimation to NERLDC by NERTS

Deliberation in the meeting:

NERTS assured that such type of incident would not recur in the future. NERLDC requested all constituents to give prior intimation before doing any such works.

The Sub-Committee noted as above.

Action: NERTS

D.30 Over drawl of States during Low Frequency

NERLDC highlighted the overdrawal of almost all states during low frequency in the grid.

Deliberation in the meeting:

The forum deliberated that in the present DSM(4th amendment) regime scheduling the peak hours in negative i.e. under-drawal mode is difficult because of the following reasons:-

- Most of the states are managing ZC by tinkering with the requisition. In peak hours even though full requisition is given it is far short of demand.
- buying from the market to be in underdrawal is an expensive proposition.

The forum unanimously requested NERPC to vent the concerns of the states, generating utilities to CERC at appropriate forum.

NERLDC requested all constituents to strictly adhere to their schedules during low frequency in the grid.

The Sub-Committee noted as above.

Action: NERPC/All SLDCs

D.31 Protection issues

- Near miss incidents with multiple tripping of 400 kV Silchar — Imphal I line on 26.01.19, 27.01.19 & 29.01.19 due to synchronization of line at 400 kV level without thorough patrolling & ensuring adequate RoW — Action plan from NERTS requested to avert future incidents. Letter No NERLDC/SO-I/NERTS/2019/2571 is enclosed as Annexure-13.
- Simultaneous Tripping of 400 kV Bongaigaon — Byrnihat line and 400 kV Bongaigaon — Azara line on 29.01.19 (list of simultaneous tripping of NETC lines during the past 2 years enclosed as Annexure-14) — Action plan from NETC requested with root cause analysis to avert future incidents

Deliberation in the meeting:

After detailed deliberation, the forum referred the matter to the next Sub-group meeting for further discussion and RCA.

The Sub-Committee noted as above.

Action: NERPC

D.32 RGMO performance analysis of instances during January 2019

NERLDC presented a report on RGMO performance for an event on 05th Feb 2019 at 11:57 Hrs when load loss of approx. 869 MW occurred in Northern Region wherein the following generators have not given the desired response:

-Palatana GTG-I -BgTPP Unit – II

And the following generators have given negative response:

-Palatana GTG-II, STG-I/II -Kopili Unit#I

-BgTPP Unit #I

Deliberation in the meeting:

The forum requested OTPC, NEEPCO and NTPC to analyse the same and revert back. NERLDC requested all ISGS to share unit wise GDAM/ DAS Data for all such events whenever intimation of such events is given by NERLDC via email. If DAS data not submitted by Generators, SCADA data shall be considered for calculation of RGMO response.

The Sub-Committee noted as above.

Action: OTPC, NEEPCO, NTPC

D.33 Review of feeder details for AUFR & df/dt in NER grid

Deliberation in the meeting:

Director, NERPC stated that there are no df/dt relays in NER. For UFR the feeder details viz. name, average loading, possible expected relief etc. are being tabulated during the Inspection process.

The Sub-Committee noted as above.

D.34 First time Charging of New Elements

- Furnishing technical parameters of the transmission element by CTU / STU in the standard format required for network modelling while requesting permission for first time charging (Format enclosed as *Annexure-19*)
- Strict compliance of CERC approved schedule for seeking permission & submission of required data formats enabling RLDC / NLDC to accord permission on time for first time charging of elements
- Proposal for First Time Charging of elements of Intra State Transmission System:
- Approval from NERLDC for elements of 400 kV & above voltage level
- Submission of undertaking in respect of Protection System and Telemetry & Communication for elements of 132 kV & above voltage level

Deliberation in the meeting:

Forum agreed the proposal by NERLDC (SI.No.1 & SI.No.3) and requested utilities to follow the same. Procedure for interconnection of a new Transmission Element of 400 kV and above voltage level connected to node of Intra STS is attached as **Annexure-D.34a**. Procedure for interconnection of a new Transmission Element of 132 kV and above voltage level connected to node of Intra STS is attached as **Annexure-D.34b**. Format for furnishing technical parameters is attached as **Annexure-D**.

Forum requested all Transmission utilities to follow the schedule as well as submit all relevant formats to NERLDC as per approved procedure to accord permission on time for first time charging of elements.

The Sub-Committee noted as above.

Action: All utilities

D.35 Improvement of SCADA data availability:

Deliberation in the meeting:

The forum noted the requirement of 100% data availability at NERLDC and referred the matter to the next NETeST for further deliberation

The Sub-Committee noted as above.

D.36 Providing High speed, reliable internet connection by all ISGS & SLDCs

Deliberation in the meeting:

CGM, NERLDC stated that in light of the commissioning of WBES it has become very essential for all the ISGSs and SLDCs to have high speed internet connection. The forum noted that the matter has already been taken up in the 19th NERPC meeting for urgent action. The members requested NERLDC to explore the following:

- a. A Lite version of WBES website with less features. This will enable punching requisition/DC even over 2G/EDGE network,
- b. USSD based application for transmission of schedule related information in real time. NERLDC agreed to the same.

The Sub-Committee noted as above.

Action: all ISGSs, SLDCs, NERLDC.

D.37 Bus Configuration changes of Critical Nodes

Bus Configuration changes of Critical Nodes for reliable operation of NER Power System

Deliberation in the meeting:

NERLDC highlighted the backdrop of the item. The incident of Bus outage at Silchar with no interruption in supply on 15.12.18 was discussed. The forum felt that bus configuration of Silchar may be reviewed in light of the above incident. It requested the Sub-group to make suitable recommendations so that the same may be referred to CEA/CTU for resolution.

The Sub-Committee noted as above.

Action: NERTS, NERLDC, NERPC..

D.38 Assessment of TTC, TRM & ATC by SLDC on respective Inter-State Transmission Corridor and submission by 20.02.2019 positively

Deliberation in the meeting:

The forum requested all the SLDCs to carry out the TTC/ATC calculations and decided that SLDC Ar. Pradesh would give presentation in the next OCC.

The Sub-Committee noted as above.

Action: all SLDCs.

D.39 Ratification of Technical and Commercial data for computation of PoC Charges and Losses for April to June'19 (Q1 of 2019-20)

The Sub-Committee ratified the demand and generation data for Q1 of 2019-20.

The final figures are as follows:

Sl No	State	Ratified Demand figures in MW
1	Arunachal Pradesh	127
2	Assam	1770
3	Manipur	186
4	Meghalaya	317
5	Mizoram	99
6	Nagaland	130
7	Tripura	341

Sl. No.	Entities	Region	Ratified Generation figures in MW
1	AGTPP, NEEPCO	NER	101
2	Doyang, NEEPCO	NER	56
3	Kopili, NEEPCO	NER	184
4	Kopili 2, NEEPCO	NER	22
5	Khandong, NEEPCO	NER	48
6	Ranganadi, NEEPCO	NER	401
7	AGBPP_Kathalguri	NER	231
8	Loktak, NHPC	NER	105
9	Palatana GBPP	NER	680
10	Bongaigaon_NTPC	NER	560
11	Pare	NER	110
12	Tuirial HEP	NER	56
13	Arunachal Pradesh	NER	No Generation
14	Assam	NER	254
15	Manipur	NER	No Generation
16	Meghalaya	NER	261
17	Mizoram	NER	8
18	Nagaland	NER	12
19	Tripura	NER	166

NERLDC informed that if data is not submitted on time, projected data will be considered. Members agreed to the same.

The Sub-Committee noted as above.

D.40 Accurate Load forecasting by SLDCs as per IEGC c1.5.3 for better system operation

Deliberation in the meeting:

RMSE for the month of Dec'18 is as follows:

% Error with Actual Data (Forecasted by States)							
	Ar Pradesh	Assam	Manipur	Meghalaya	Mizoram	Nagaland	Tripura
Median	16	6	7	10	32	12	8

Mizoram & Arunachal Pradesh SLDCs are requested to check the methodology for improving the load forecast.

The Sub-Committee noted as above.

Action: all SLDCs.

D.41 Reliable power supply to Manipur system

For Ensuring reliable power supply to Manipur system, following actions were suggested by NERLDC:

- a. 132 kV Jiribam – Jiribam (MA) – Rengpang – Loktak link to be kept in loop
- b. Restoration of 132 kV Dimapur – Imphal line
- c. Upgradation of 132 kV Kohima – Karong – Imphal (MSPCL) link

This will be reviewed in the next OCC Meeting due to absence of member from MSPCL.

The Sub-Committee noted as above.

Action: NERLDC, MSPCL.

D.42 Charging of 400 kV Silchar (PG) — Melriat (PG) I (Future) Main Bay for completing GIS Dia of 420 kV, 125 MVAR Bus Reactor at 400/132 kV Silchar Substation

Deliberation in the meeting:

The forum requested NERTS to complete the dia at the earliest and referred to next SCM.

The Sub-Committee noted as above.

Action: NERTS.

D.43 Updating the List of Important Grid Elements of NER

As per inputs received from utilities, List of Important Grid Elements of NER is updated till 31st Dec' 18. All the Utilities are requested to update the excel file circulated vide email dated 06.02.19.

The Sub-Committee noted as above.

D.44 Implementation of Security Constrained Economic Dispatch (SCED)

Implementation of Security Constrained Economic Dispatch (SCED) of Inter-State Generating Stations Pan-India on pilot basis w.e.f. 01.04.2019 was presented by NLDC(attached at **Annexure-D.44**)

The Sub-Committee noted as above.

D.45 Installation of TARA device:

Installation of TARA device in Tripura is completed. Access ID & Password provided by CDAC TO Tripura. But since after installation details not updating at the website. Issues were communicated to CDAC engineer but not taken any initiative to restore. Moreover, Server has been delivered to SLDC but HMI software is not installed. Needs CDAC response in this issue .

Deliberation in the meeting:

Pls refer to discussion in item No. **D.4.**

The Sub-Committee noted as above.

D.46 Construction of Bay for 132kV Agia-Nongalbibra Line at 220kV Agia Sub Station, Agia, Assam

Stringing of 2nd Circuit 132kV Nongalbibra -Agia Line (SPA Scheme) Rs. 1.11 Cr Deposited by MePTCL by SBI Chq No. 511140 Dt. 15.03.2016 for the above work. Stringing of the Line Completed in 2018.

Deliberation in the meeting:

MePTCL requested AEGCL to kindly intimate the latest status at the earliest. EE, System Protection, MePTCL, informed the Chair on the observations of TESSG on the DPR's for re conductoring of lines with HTLS submitted by MePTCL wherein the observations desires that the OPGW component be excluded from the scope of works in DPR's. He requested the Chair to take up with the matter with NLDC for consideration of the OPGW item in DPR.

EE, System Protection, MePTCL, also pointed on the recent TESSG observations on the DPR for Reliable Communication seeking Board's approval for 50 % funding and requested the Chair to take up the matter with POSOCO NLDC.

Director NERPC informed the issue has been taken up with MoP GOI and assure to share MePTCL with a copy of the correspondence.

The Sub-Committee noted as above.

Action: AEGCL

D.47 Preparedness for secured grid operation during High Wind and Monsoon Season:

Entire NER generally experiences heavy windy weather followed by rain from the month of March onwards resulting tripping of elements due to lightning, Grid disturbances & Grid Incidents, load crash, etc.

Deliberation in the meeting:

It was decided that all transmission utilities should submit the schedule to NERPC by 25th Feb'19.

For safe and secure operation of grid during High Wind and Monsoon Season, following actions are suggested by NERLDC:

- a. All substations, generating stations and control centers of state power systems are requested to maintain alert status
- b. Ensure appropriate action for proper load – generation balance of respective systems by SLDCs
- c. MVAR injection / absorption according to machine capability curve as per system requirement & operation synchronous condenser mode as per machine design ensuring frequency by Generators
- d. Appropriate action to keep Line loading and voltage within prescribed limit by SLDCs

The Sub-Committee noted as above.

Action: All regional utilities

D.48 Intimation of outages in State Power System by SLDCs on real time

Deliberation in the meeting:

NERLDC referred the Grid disturbance dated 16.01.19 in Meghalaya System where information of R&M works in 132 kV EPIP-II substation of MePTCL was not intimated to NERLDC on real time. Grid disturbance occurred while charging the 132 kV EPIP 2 – EPIP 1 line-2 after completion of the works.

After deliberations, it was decided that outage of elements of 132 kV and above voltage level in the state power system is to be intimated to NERLDC just before taking the shutdown by SLDCs.

The Sub-Committee noted as above.

Action: All regional utilities

D. 49 Tentative schedule for Black Start & Restoration Procedure Mock exercise in NER during the year 2019

Deliberation in the meeting:

The forum requested NERLDC to prepare and circulate the tentative schedule for Black Start & Restoration Procedure Mock exercise. The tentative schedule is as follows:

AGTCCPP	March 2019
Loktak	April 2019
Khandong & Kopili st II	May 2019
Kopili	June 2019
AGBPP	July 2019
Ranganadi	August 2019
Pare	September 2019
Doyang	October 2019

Respective ISGSs are requested to finalize the dates for the mock exercise as per the tentative schedule.

The Sub-Committee noted as above.

Action: NERLDC

D.50. Procurement of additional 70 Laptops:

Deliberation in the meeting:

NERTS intimated that LOA for software would be issued by Feb'19 and Laptops would be distributed by March'19.

The Sub-Committee noted as above.

Action: NERTS

D.51. Procurement of DCD:

Deliberation in the meeting:

NERTS intimated that the DCDs would be distributed as per the list given by NERLDC. NERLDC would give the list within a week.

The Sub-Committee noted as above.

Action: NERTS

D.52. Time drift in SEMs.

Deliberation in the meeting:

It was agreed that the meters drifted by more than 10 minutes would be identified and replaced. For remaining meters, regular time correction command would be provided by respective utility. NERLDC would issue advice to NERTS for replacement of drifted meters.

The Sub-Committee noted as above.

Action: NERTS

D.53. Non-receipt of SEM / Time Drift data:

Deliberation in the meeting:

It was mentioned that many locations not having DCD could not send readings. It was agreed that NERLDC in its list as D.56 would include priority locations for DCD.

The Sub-Committee noted as above.

Action: NERTS

D.54. Error observed in Meter readings:

Deliberation in the meeting:

- a. Panchgram end of 132 kV Badarpur feeder, Meter no. 6872 reading half of other end, meter 6872 data is suspect.

NERTS stated that the minimum CT ratio available in the newly installed CT at Panchgram end is 600A as such it shows half of the value.

The Sub-Committee noted as above.

Action: NERTS

- b. Karong end of 132 kV Kohima line, meter no. NP-8373-A, sign reversal observed.

NERTS stated that CT polarity shall be reversed. To be completed by 20.02.19 (It was decided to rectify the issue immediately but the same could not be done due to critical Law & Order situation in Imphal).

The Sub-Committee noted as above.

Action: NERTS

ADDITIONAL AGENDA ITEM:

D.55 Monthly NETeST meeting:

Members unanimously requested NERPC to hold NETeST meeting on a monthly basis for frequent monitoring of communication links.

The Sub-Committee noted as above.

Action: NERPC

D.56 MATLAB training at NERLDC:

NERLDC informed that Basic level Training on MATLAB is scheduled to be held at NERLDC, Shillong w.e.f 15.03.2019 to 17.03.2019 as a commitment of POSOCO for Capacity Building of SLDCs. SLDCs are requested to nominate 1 (one) official for this training program.

The Sub-Committee noted as above.

Action: NERLDC, SLDCs

Date & Venue of next OCC meeting

It is proposed to hold the 154th OCC meeting of NERPC on second week of March, 2019. However, the exact date and venue will be intimated in due course.

The meeting ended with thanks to the Chair.

Annexure-I

List of Participants in the 153rd OCC Meeting held on 14th February, 2019

SN	Name & Designation	Organization	Contact No.
1.	Sh. Domo Kamduk, A.E, SLDC	Ar. Pradesh	09436671717
2.	Sh. K.Goswami, Consultant, APDCL	Assam	09864020019
3.	Sh. Dipesh Ch. Das, AGM (LDC)	Assam	09954110254
4.	Sh. Bimal Ch. Borah, AGM, SLDC	Assam	09475119248
5.	Sh. Santosh Sharma, Manager, MSPDCL	Manipur	08119044134
6.	Sh. F.E Kharshiing, SE, SLDC	Meghalaya	09863066960
7.	Sh. B.Nikhla, EE (SP)	Meghalaya	09436314163
8.	Sh. W.Khyriem, EE, GSPD	Meghalaya	09856007107
9.	Sh. R.G.L. Mawlong, EE, EM	Meghalaya	09436998350
10.	Sh. Marc N.Tariang, JE (System Protection)	Meghalaya	07005620013
11.	Lalrinmawia, SE	Mizoram	09436140764
12.	Sh. Benjamin L.Tlumtea, Sr. E.E, SLDC	Mizoram	09436151424
13.	Sh. J.H.Laithangliana, Sr.EE (Comml.)	Mizoram	09436151424
14.	Sh. Nitovi Wotsa, EE, SLDC	Nagaland	09436004928
15.	Sh. Anil Debbarma, DGM, SOD, SLDC	Tripura	09612589250
16.	Sh. Mrinal Paul, Manager	Tripura	09436137022
17.	Sh. Debabrata Pal, Sr. Manager	Tripura	09436500244
18.	Sh. Joypal Roy, Sr. Manager (E/M)	NEEPCO	09435577726
19.	Sh. Suranjan Sarkar, Sr. Manager (E/M)	NEEPCO	08974009294
20.	Sh. V.Suresh, CGM	NERLDC	09449599156
21.	Sh. R. Sutradhar , DGM (MO)	NERLDC	09436302714
22.	Sh. Sourav Mondal, Dy.Manager	NERLDC	09402102354
23.	Sh. Ankit Jain, Dy. Manager	NERLDC	0943633538
24.	Sh. Sumit Kumar,Asst.Manager	NERLDC	-
25.	Sh. Jerin Jacob, Asst. Manager	NERLDC	09602120113
26.	Sh. Samir Saxena, Sr.GM	NLDC	-

27.	Sh. P.Kanungo, Sr. GM	PGCIL	09436302823
28.	Sh.Deva Prasad Paul, Manager	PGCIL	09435382360
29.	Sh. Pulak Deka, Manager (M)	NHPC	09435187838
30.	Sh. Bibek Roy, DGM (O&M)/Plant)	OTPC	08794006803
31.	Sh. Narendra Gupta, Sr.Manager	OTPC	09774233426
32.	Sh. S.R. Das, Sr. Mgr. (Elect)	OTPC	09612400784
33.	Sh. A.K.Mishra, AGM (OS), ER-II-HQ	NTPC	09437966528
34.	Sh. B.Choudhury, AGM(EEMG), BgTPP	NTPC	09435503167
35.	Sh. Sistla Madhukar, Dy. Manager	Sterlite Power	09977585032
36.	Sh. Hardeep Singh, Dy.Manager	Sterlite Power	08116444616
37.	Sh. Abhijit Das, AM	Sterlite Power	09070041145
38.	Sh. P.K. Mishra, Member secretary	NERPC	09968380242
39.	Sh. B. Lyngkhoi, Director (O&P)	NERPC	09436163419
40.	Sh. S.M.Aimol, Dy.Director	NERPC	08974002106
41.	Sh. S. Mukherjee, AD	NERPC	08794277306



उ.पू.क्षे गिड प्रदर्शन

NER GRID PERFORMANCE

For Month: January 2019

NORTH EASTERN REGIONAL LOAD DESPATCH CENTRE

POSOCO, SHILLONG

1

Contents



Highlights

Frequency
Profile

Voltage
Profile &
Issues

Cross Border
Transaction

Generation
Pattern

Inter
Regional
Exchange

Energy
Availability
of States

Maximum
Demand Met

Drawl
Pattern of
States

Violation
Messages

STOA
Transactions

Water Level
of reservoir

2

Contents



[Energy
Content of
HEPs](#)

[GD & GI
counts](#)

[Agenda](#)

3

Highlights for the month of January 2019



- 1. First Wind Power LTA in NER region by Assam:**
Scheduling of Mytrah wind power project (Southern Region) which has been part commissioned with 128.7 MW has been started w.e.f 00:00 hrs of 30-01- 19. Assam has 25.74 MW LTA with the same.
- 2. BgTPP Unit III trial run operation started on 11-02-19**
- 3. Arunachal Pradesh has been allocated 7.14 % share from Unchahar-I (IC- 420 MW) in Northern Region and the scheduling of same has commenced w.e.f. 00:00 hrs. of 01/02/19**

[BACK](#)

4

Blockwise Average wind LTA schedule for Assam

Maximum Wind Schedule	16.22	12-02-2019
Minimum Wind Schedule	0	09-02-2019

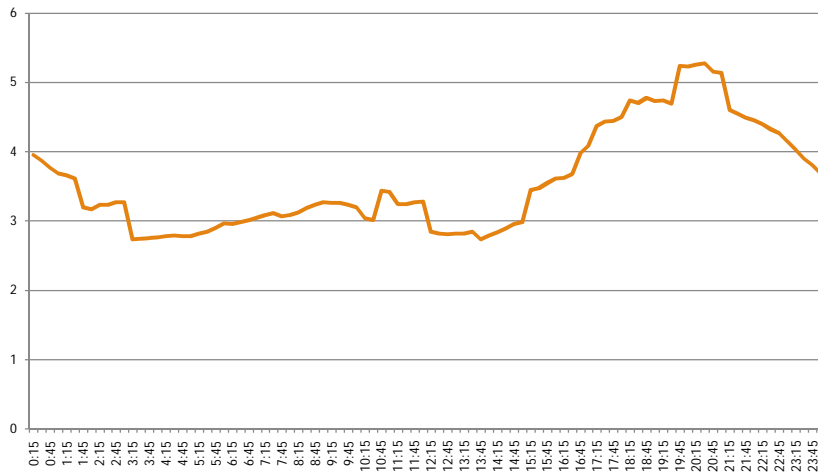

Frequency Profile for the month of January'19:

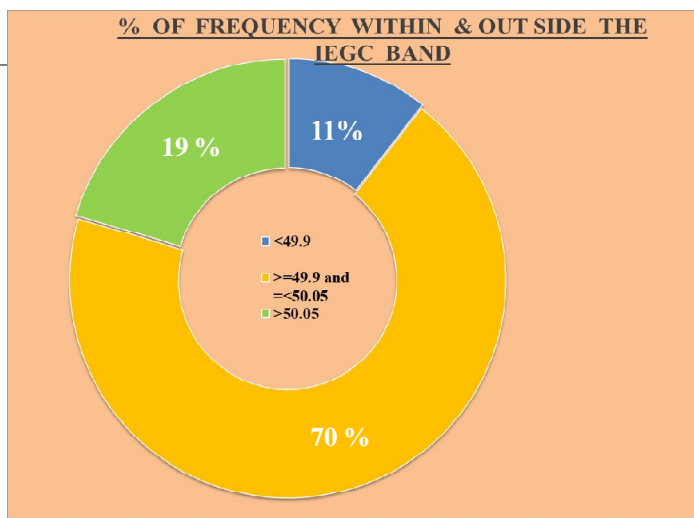

FDI for the month of January			
Sl No.		Jan'18	Jan'19
1	FDI	0.221	0.298

Daily Frequency Profile

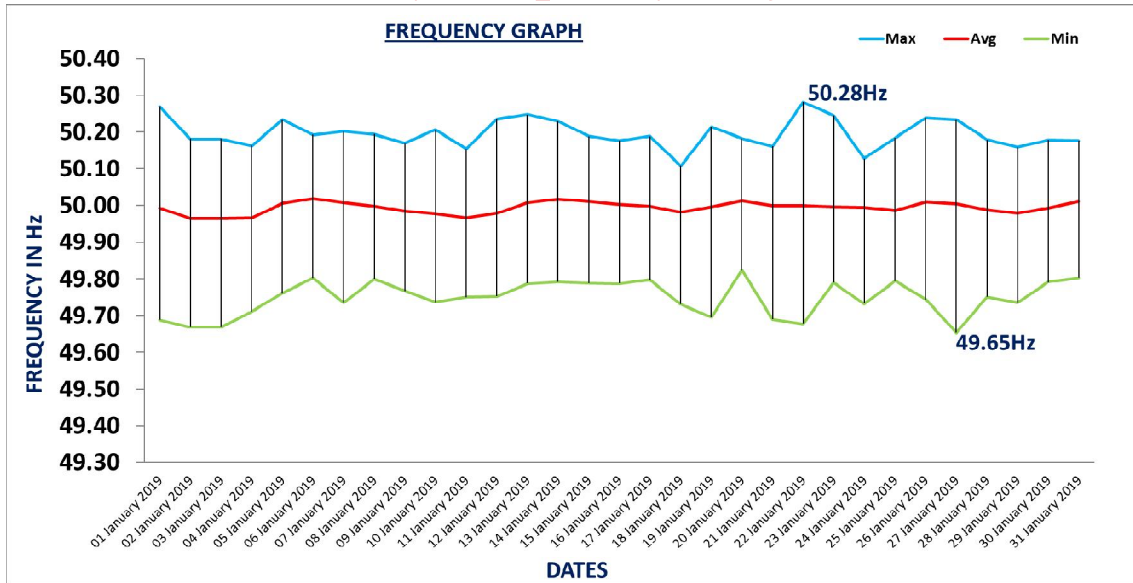

[BACK](#)

Voltage Profile Issue Voltage Deviation Index (outside IEGC range) in % (Agenda)



VDI for the month of January			
SI No.	Name of 400 kV Node	Jan'18	Jan'19
1	Azara (AEGCL)	0.000	0.000
2	Balipara (PG)	0.001	0.001
3	BgTPP (NTPC)	0.001	0.001
4	Biswanath Chariali (PG)	0.000	0.000
5	Bongaigaon (PG)	0.000	0.000
6	Byrnihat (MePTCL)	0.003	0.001
7	Misa (PG)	0.026	0.069
8	Palatana (OTPC)	0.002	0.000
9	Ranganadi (NEEPCO)	0.064	0.212
10	Silchar (PG)	0.002	0.000



Number of 400 kV Lines opened on Overvoltage for Jan'19

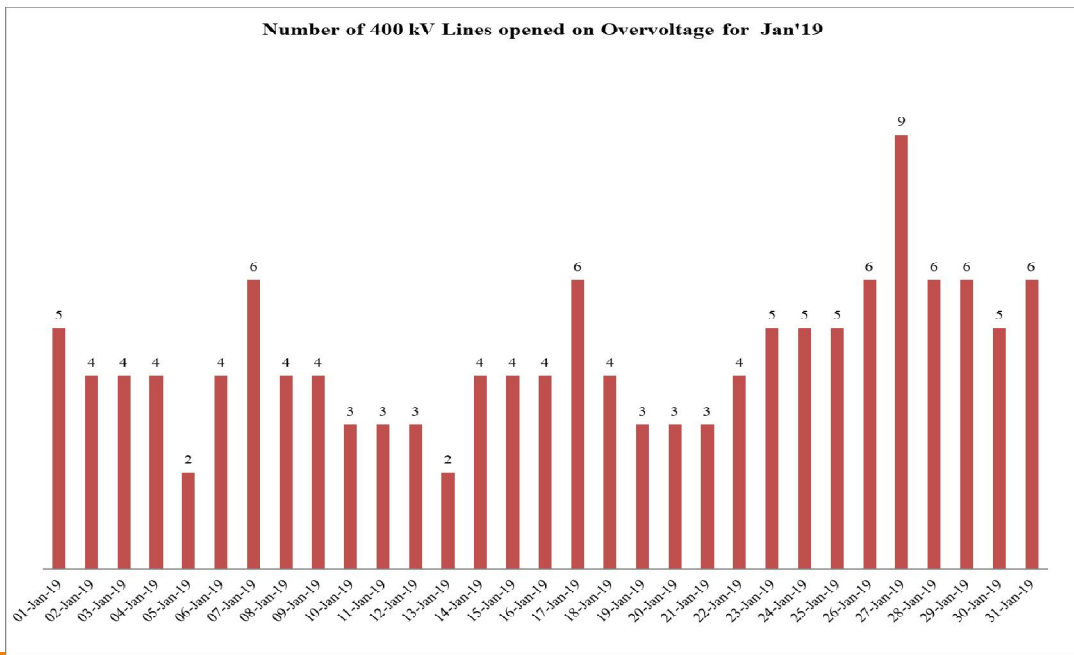

Number of Hours 400 kV Lines kept opened due to Over Voltage during Jan'19

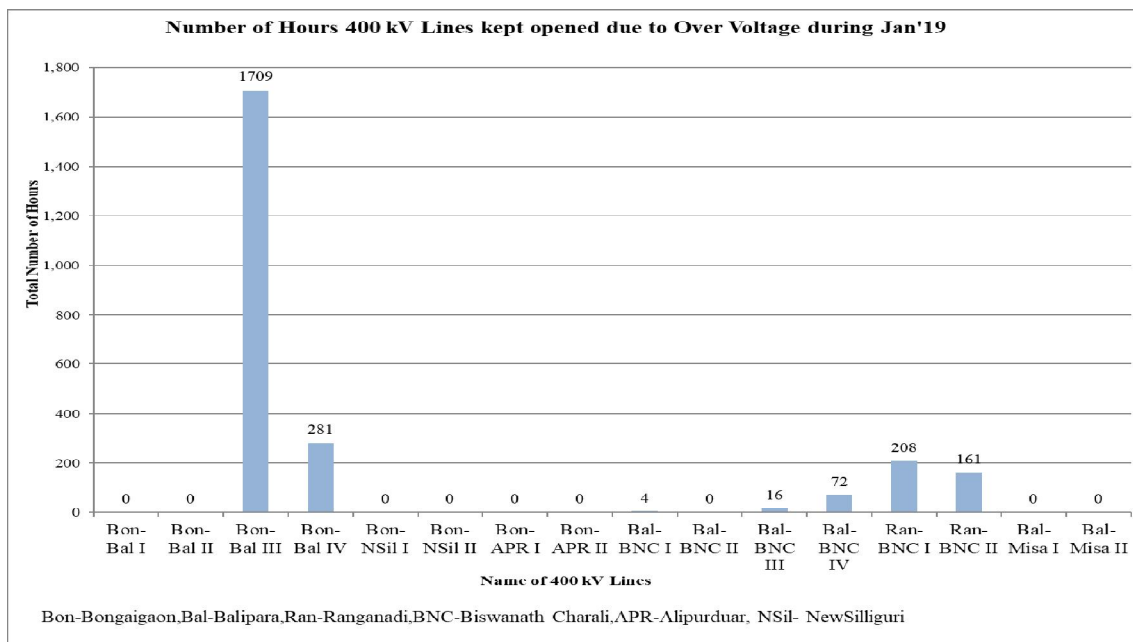



■ Maximum No. Lines Opened in a Day due to Over Voltage

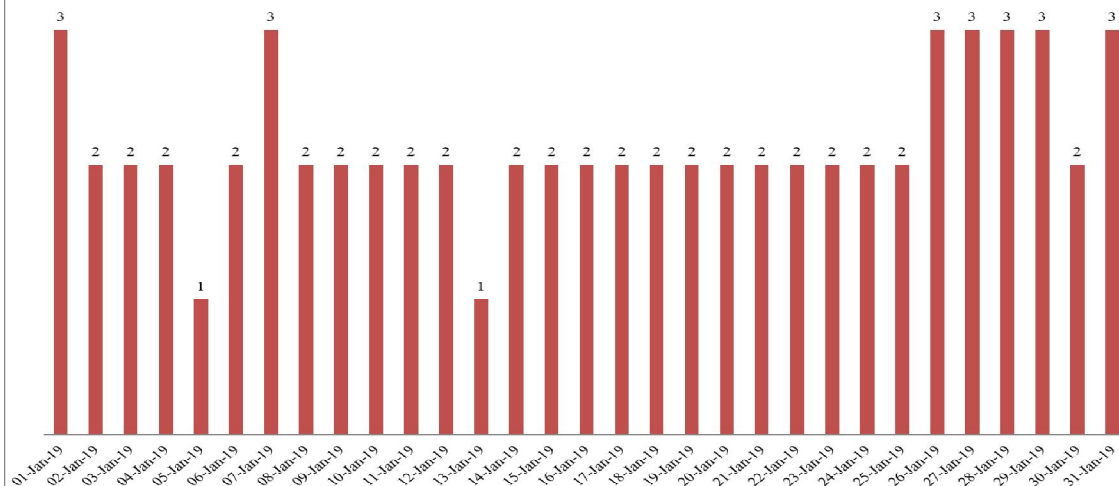

[BACK](#)



Cross Border Transactions (in MU)

Net Inter-Country Power Exchange(in MU)	
Import (+)/ Exp (-) by Bhutan	3.343
Drawal by Bangladesh	65
Drawal by Myanmar	0.453

[BACK](#)

Comparison of Generation Pattern (MU)

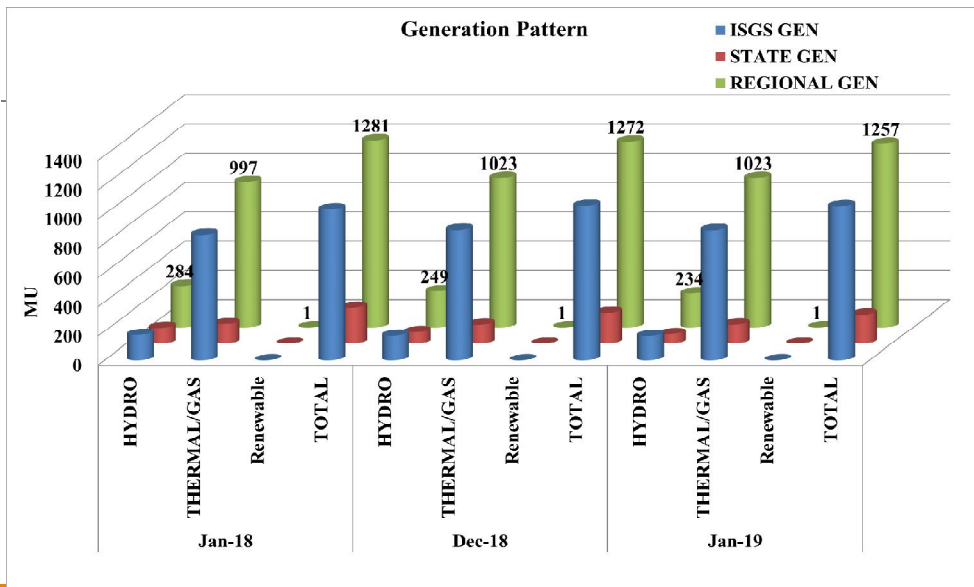

[BACK](#)

Comparison of Inter – Regional Exchange in MU

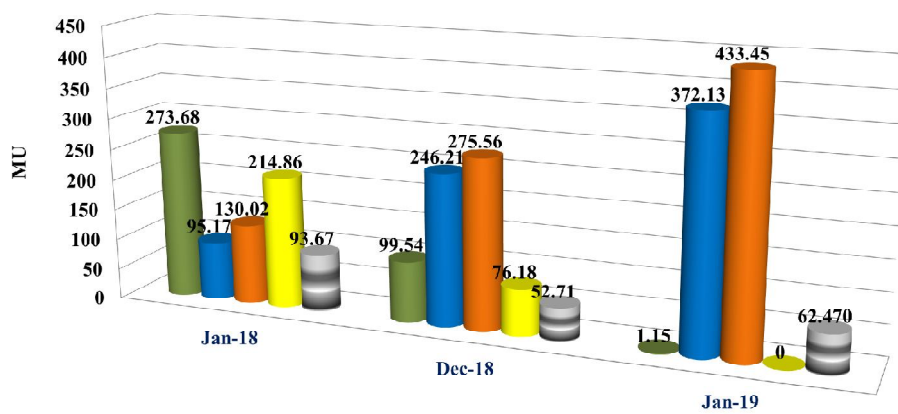

	Jan-18	Dec-18	Jan-19
ER-NER	273.68	99.54	1.15
NER-NER	95.17	246.21	372.13
NR-NER	130.02	275.56	433.45
NER-NR	214.86	76.18	0
Net Import(+)/Export(-)	93.67	52.71	62.470



SRI for the month of January

Sl No.		Jan'18	Jan'19
1	ER-NER Import TTC Violation	0.00%	0.00%
	NER-ER Export TTC Violation	0.00%	0.00%
2	ER-NER Import ATC Violation	0.00%	0.00%
	NER-ER Export ATC Violation	0.00%	0.00%
3	400 kV Bongaigaon wrt Balipara (Max angular diff between buses)	8.9	6.1
	400 kV Balipara wrt Misa (Max angular diff between buses)	5.1	1.4
	400 kV Binaguri wrt Bongaigaon (Max angular diff between buses)	7.2	4.2

[BACK](#)



Comparison of Energy Availability (in MU)

Constituents	Energy Met (MU)		Difference	% Difference	Energy Met (MU) per Day	
	Jan-18	Jan-19			Jan-18	Jan-19
Arunachal	67.09	68.24	1.15	1.71	2.24	2.27
Assam	703.02	711.61	8.60	1.22	23.43	23.72
Manipur	83.57	85.75	2.18	2.61	2.79	2.86
Meghalaya	188.00	198.64	10.65	5.66	6.27	6.62
Mizoram	59.65	54.55	-5.11	-8.56	1.99	1.82
Nagaland	63.09	64.14	1.05	1.66	2.10	2.14
Tripura(Excluding Bangladesh)	107.48	115.91	8.44	7.85	3.58	3.86
Region(Excluding Bangladesh)	1271.90	1298.85	26.95	2.12	42.40	43.29

[BACK](#)

Maximum Demand Met of states for January'19



Name of Constituents	Maximum Demand Met (MW) in January'19	Maximum Demand Met (MW) in December'18	Maximum Demand Met (MW) in January'18
Ar Pradesh	124.0	131.0	133.9
Assam	1468.0	1418.0	1510.0
Manipur	215.9	211.0	195.0
Meghalaya	372.2	366.0	331.0
Mizoram	118.9	111.0	96.0
Nagaland	137.6	133.0	124.0
Tripura(Excluding Bangladesh)	222.9	228.0	226.0
Region(Excluding Bangladesh)	2552.0	2511.0	2491.0
Max Drawal by Bangladesh	173.8	134.3	137.6
Max Drawal by Myanmar	1.5	2.1	1.8

[BACK](#)

Actual drawl against Schedule in MWh

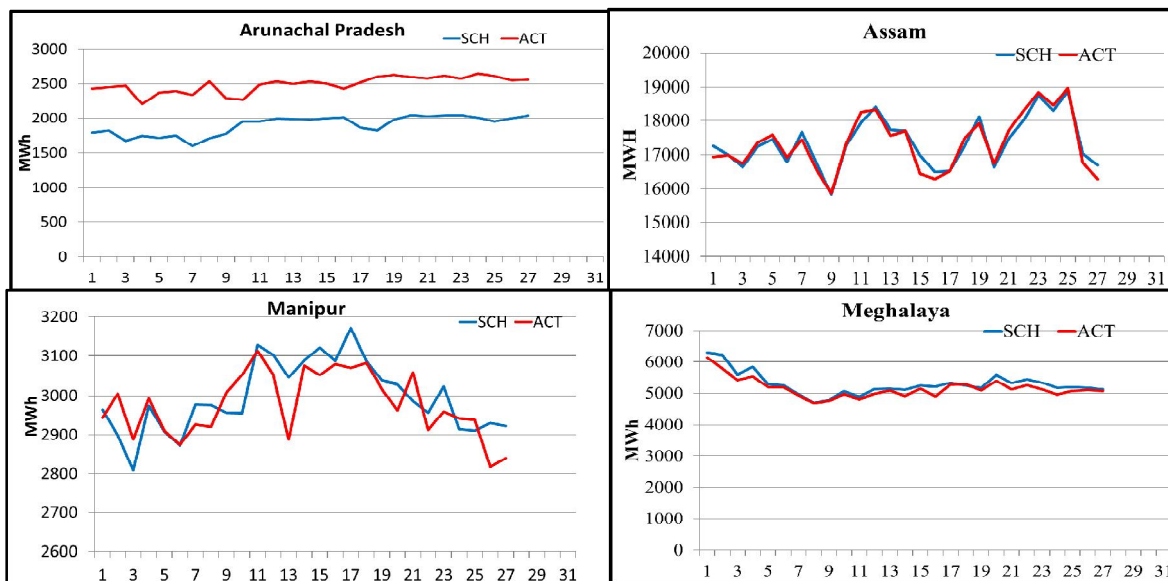

Actual drawl against Schedule in MWh

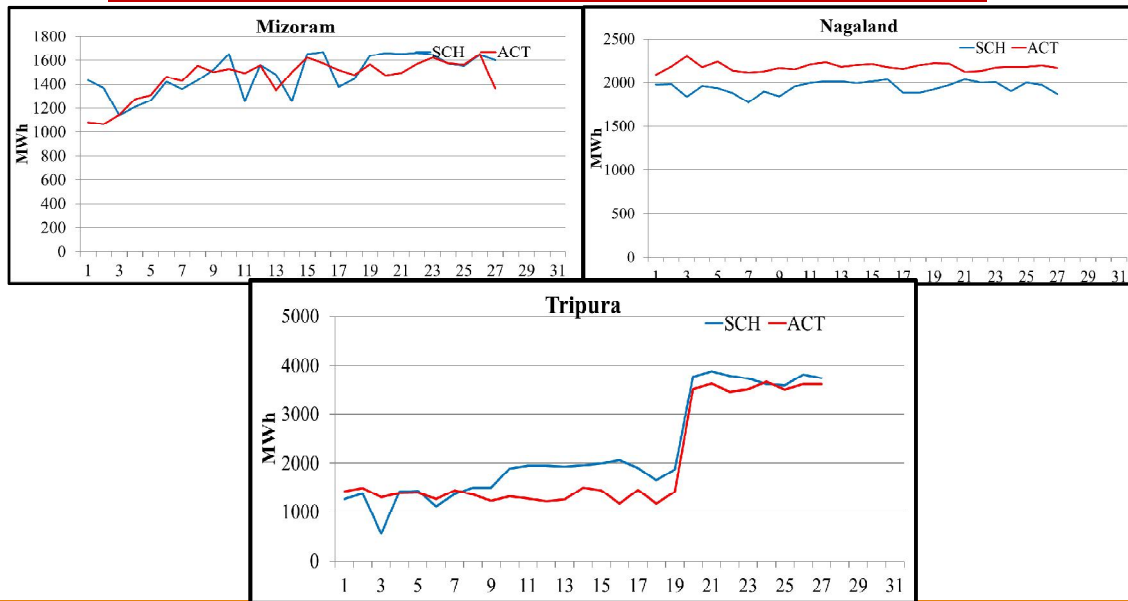

[BACK](#)

Violation Message Summary of January 2019



Constituents	Deviation Violation Message			Frequency Violation Message		
	Alert	Emergency	Total	Alert	Emergency	Total
AP	0	0	0	26	8	34
Assam	17	2	19	39	9	48
Manipur	0	0	0	30	7	37
Meghalaya	0	0	0	26	4	30
Mizoram	0	0	0	23	4	27
Nagaland	0	0	0	28	4	32
Tripura	8	3	11	34	9	43

[BACK](#)

STOA Transactions by the States

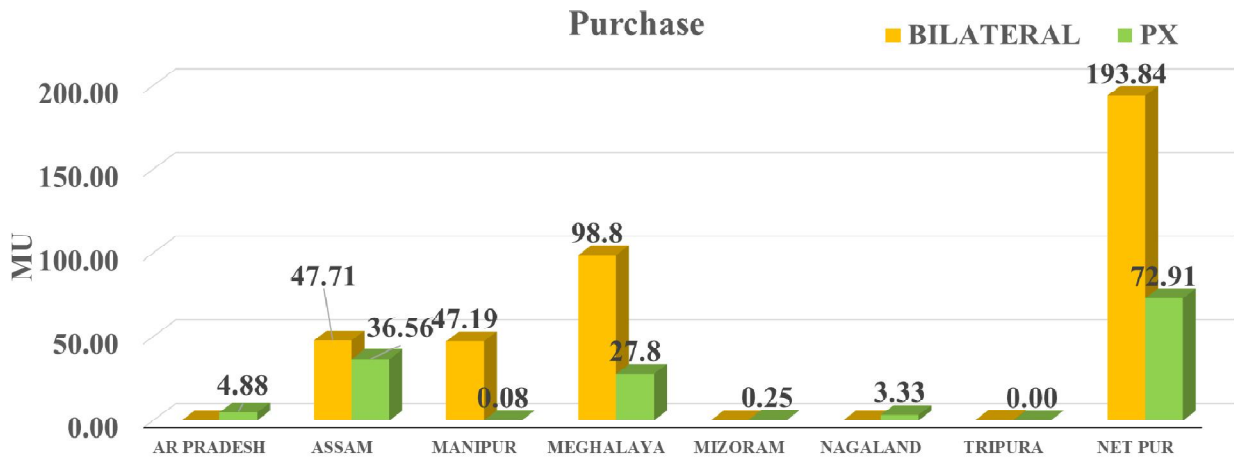

21

STOA Transactions by the States

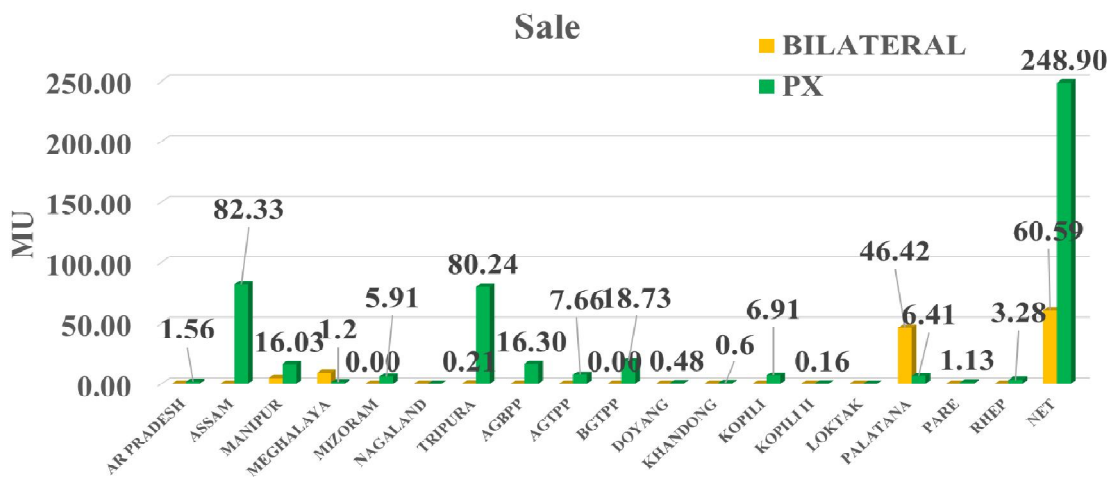

[BACK](#)

Water Level of Reservoirs in NER

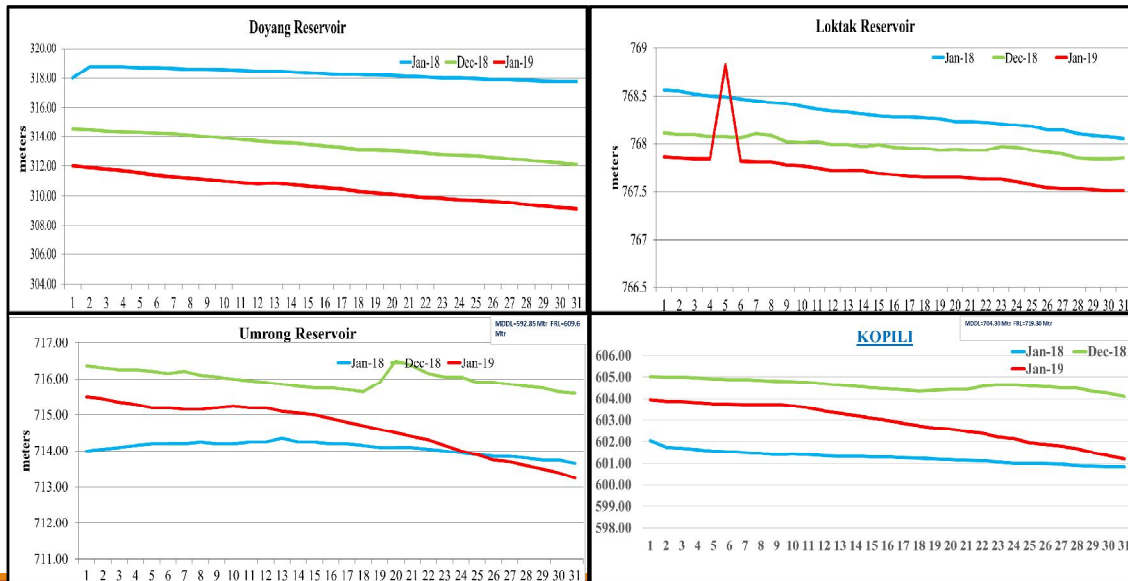

[BACK](#)

Energy Content of Hydro Plants



Plants	Reservoir Level in meters (as on 13/02/19)	MU Content	Present DC (MU)	No of days as per current Generation
Khandong + Kopili STG II	712.45	11	0.169	65
Kopili	599.74	74	0.504	147
Doyang	308.12	3	0.99	3.03
Loktak	768.31	203	0.244	832

[BACK](#)

Details of Grid Disturbance / Grid Incidents



GD & GI Count for January'19

Sl. No.	Category of GD	Total Counts
1	GI 1	2
2	GI 2	2
3	GD 1	5
4	GD 2	1
5	GD 3	0
6	GD 4	0
7	GD 5	0

[BACK](#)

Non receipt of D-3 availing request for 152nd OCCM approved shutdowns

Total no. of SD approved	136
Nos. of SD availed on D-3 basis	61
Nos. of SD not availed on D-3 basis	25
Nos. of SD not availed	50

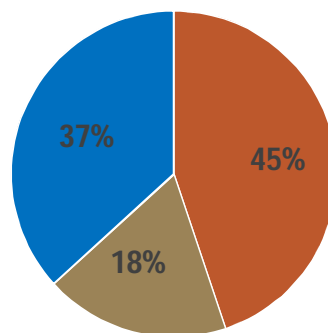

■ Nos. of SD availed on D-3 basis
 ■ Nos. of SD not availed on D-3 basis
■ Nos. of SD not availed

High percentage of non-OCC approved shutdown request

Total no. of OCC approved SD	Nos. of Non-OCC approved shutdown
136	37

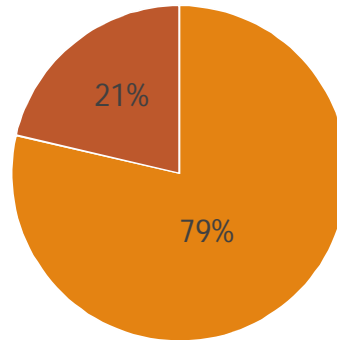

■ Total no. of OCC approved SD ■ Nos. of Non-OCC approved shutdown

27

Inordinate Delay for January 2019

Transmission Licensee	Total Delay (in Hrs)	Avg. Delay (in Hrs)	Max. Delay (in Hrs)
POWERGRID	332:52:00	04:41:18	95:44:00
NETC	00:28:00	00:14:00	00:28:00
ENICL	-	-	-

28

Agenda 2. a.b.f Progress of activities / decisions of 152nd OCC meeting of NERPC

- **Status Review: Design & implementation of SPS for Outage of 400 kV Bus – I & II at Silchar (PG) and Outage of any one circuit of 400 kV Bongaigaon – BgTPP. Study results in [Annexure SPS](#)**
- **Schedule for special meeting on review of existing SPSs & devising new SPSs as per present requirement of NER grid –**
 - **Action: NERPC & all Regional Entities requested.**
- **Operation of RHEP in Synchronous Condenser Mode: NEEPCO taking up with BHEL**
- **Joint Validation of SCADA data by NERTS & NERLDC**
- **Organizing PCC Meeting on Bi-Monthly Basis – Tentative date for next meeting**

29

Agenda 2. a.b.f Progress of activities / decisions of 152nd OCC meeting of NERPC

- **Development of consolidated Communication Path Map for NER**
- **Commissioning of 400 kV Transfer Bus at BgTPP**

30

Agenda 3. Preparedness for secured grid operation during High Wind and Monsoon Season

- Entire NER generally experiences heavy windy weather followed by rain from the month of March onwards resulting tripping of elements due to lightning, Grid disturbances & Grid Incidents, load crash and etc.
- Statistics for the last two years is as follows and Category wise tripping statistics is shown in Table in next slide

Last two years category wise tripping

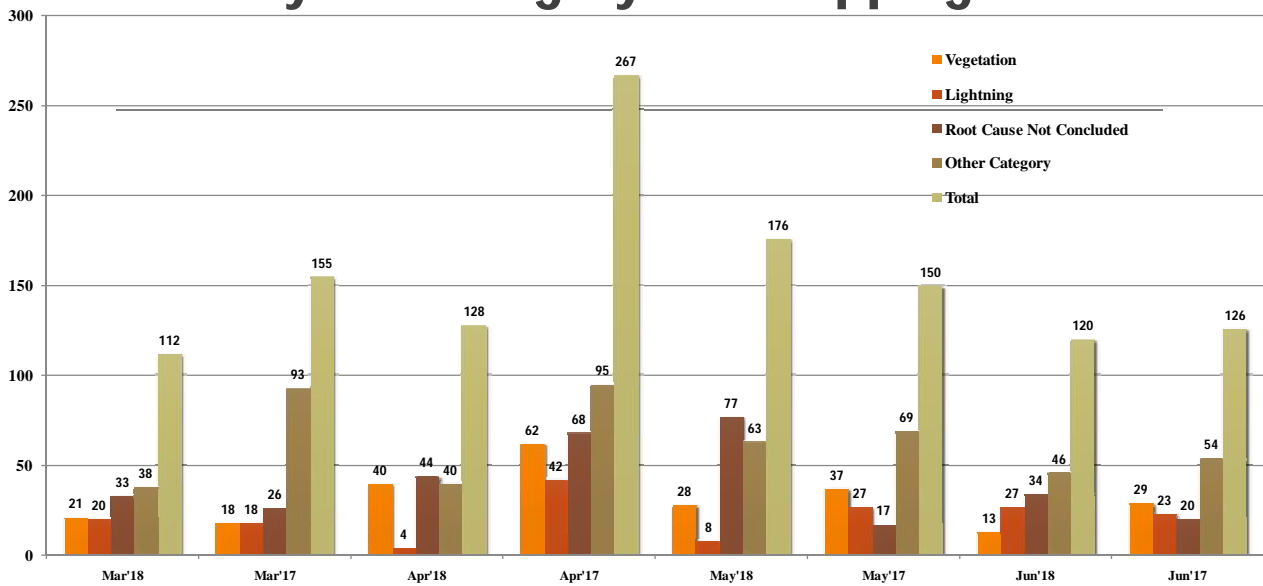

Agenda 3. Preparedness for secured grid operation during High Wind and Monsoon Season – Contd.

- To minimise such instances, all the transmission utilities requested for thorough patrolling & clearing of vegetation (especially Bamboos) ensuring adequate RoW of all transmission elements.
- All utilities are requested to furnish the schedule (say by 25th February'19) facilitating proper monitoring by RPC as per direction of CERC
- All substations, generating stations and control centers of state power systems are requested to maintain alert status

33

Agenda 3. Preparedness for secured grid operation during High Wind and Monsoon Season – Contd.

- As a part of this preparedness, following activities are suggested
 - Appropriate action for load – generation balance.
 - Keep frequency, line loading and voltage within prescribed limit.
 - During High Frequency, generation back down of machines within state power system.
 - During High Voltage, keep all 'Capacitors' out of service and all 'Bus Reactors' in service. Use 'Line Reactors' as 'Bus Reactors' after discharging the line.
 - During High Voltage, absorption of 'Reactive Power' by generating unit should be according to 'capability curves'.
 - Operation of Synchronous Condenser Mode in Hydro machine, if possible.
 - Maintain alertness on all substations, generating stations and control centers of state power systems

34

Instances of non-compliance / violation of IEGC

Agenda 4 a. Opportunity SD of 132 kV Salakati – Gelephu on 22.01.19 without prior intimation to NERLDC by NERTS



nerldc shillong <nerldccontrolroom@gmail.com>

132kV Salakati-Gelephu regarding

2 messages

nerldc shillong <nerldccontrolroom@gmail.com>
 To: nerts_cpcc <nerts_cpcc@powergrid.co.in>
 Cc: MS NERPC <nerpc@gmail.com>, V Suresh <vsuresh@posoco.in>, kaikhochin valte <kaikhochin@gmail.com>, S C De <scde@posoco.in>, Amresh Mallick <amreshmallick@posoco.in>

Tue, Jan 22, 2019 at 4:18 PM

Sir,
 Planned Shutdown of 132 kV Salakati-Gelephu T/L availed by Bhutan at 09:27 hrs dated 22-01-2019 for general maintenance work. The said S/D was withdrawn by Bhutan at 15:48 hrs vide charging code (Bhutan-136,NLDC-1197). Accordingly RLDC charging code 6150 was issued at 15:49 hrs for charging of line. However, it is come to know that POWERGRID availed opportunity S/D for testing of bay equipment's without intimating NERLDC, Shillong which is the great concern from safety and system security point of view.
 Therefore, it is requested not to avail opportunity S/D in future without prior intimation to NERLDC.
 You are requested to bring the said line into service at the earliest. **Matter may be treated as most urgent.**
 Thanking You.

सादर /Regards,
B Swagaly
 पाली प्रभारी/Shift-In-Charge
 उत्तर पूर्वी भार प्रेषण केंद्र शिलांग
 North Eastern Load Dispatch Centre Shillong



Agenda 4 b. Attending rectification work of synchronizing circuit of Misa-1 Tie bay at Balipara on 15.01.19 without prior intimation to NERLDC by NERTS

35

Agenda 4 c. Over Drawal of States during Low Grid Frequency (outside IEGC Band)

Date	Frequency(Hz)	States	Schedule(MW)	Actual(MW)	Overdrawal MW
22.01.2019	49.68	Arunachal Pradesh	82	109	26.45
		Assam	726	826	100.76
02.01.2019	49.77	Assam	725	737	12.06
		Meghalaya	276	290	14.20
		Tripura	42	76	33.83
05.01.2019	49.77	Manipur	169	184	15.22
		Arunachal Pradesh	64	82	18.03
		Assam	644	677	33.05
		Tripura	48	60	12.31
		Manipur	96	117	20.35

36

Network Issues
**Agenda 5.Overloading of inter-state lines to the main NER
 Grid/ All India Grid**

Sl. No.	Date	Time	Line/ICT	Affected States	Overloading
1	16/01/2019	17:41	132 kV Badarpur-Panchgram	Assam	72 MW
2	16/01/2019	17:44	132 kV Melriat-Zuangtui	Mizoram	74 MW
3	27/07/2018	20:17	132 kV Kamalpur-Rangia	Assam	79.5 MW
4	16/07/2018	15:15	125 MVA ICT-I Palatana	Tripura	123 MW
5	25/07/2018	18:59	125 MVA ICT-I Palatana	Tripura	121 MW
6	25/07/2018	18:59	125 MVA ICT-II Palatana	Tripura	115 MW
7	30/06/2018	18:34	132 kV Pare-Lekhi	Assam, AP	80 MW
8	15/06/2018	19:11	132 kV Pare-Lekhi	Assam, AP	83 MW
9	07/06/2018	18:34	132 kV Pare-Lekhi	Assam, AP	81 MW
10	06/06/2018	19:12	132 kV Pare-Lekhi	Assam, AP	82 MW

37

**Agenda 6. Intimation of outages in State Power System by
 SLDCs on real time**

Grid disturbance dated 16.01.19 in Meghalaya System

38

Agenda 7. Ensuring reliable power supply to Manipur system

- To ensure reliable power supply to Manipur System, the following three steps can be taken:
- 132 kV Jiribam – Jiribam (MA) – Rengpang – Loktak link to be kept in loop
 - Restoration of 132 kV Dimapur – Imphal line
 - Upgradation of 132 kV Kohima – Karong – Imphal (MSPCL) link

Study Results for the above is Given in [Annexure Manipur](#)

39

Voltage Profile Issues

Agenda 8. Multiple outage of Reactors and ongoing shutdown of hydro units of RHEP , Doyang, Kopili, Kopili Stg 2, Loktak causing High Voltage Issue

Utility	Location	Voltage Level	Name of Bus/Line	Capacity(MVAR)	Type	Remarks
POWERGRID	BONGAIGAON	400 kV	Bus Reactor V	125	BUS	CSD(since 17.01.2019)
POWERGRID	BONGAIGAON	400 kV	New Siliguri I	63	LINE	Reactor is being replaced with spare reactor available at Bongaigaon. Work under progress.(since 04.07.2018)
POWERGRID	BONGAIGAON	400 kV	Azara	63	LINE	From 10/10/18 due to broken lock pin of Y phase lead from 08:10 Hrs(since 10.11.2018)
MeECL	BYRNIHAT	400 kV	Bus	63	BUS	since 09.12.14

40

Agenda 11. Restoration / Commissioning of Reactors – Status Review

Agenda 12. Tentative schedule for Reactive Power Capability testing of generating units

41

Protection issues

Agenda 13. Near miss incidents with multiple Tripping of 400 kV Silchar – Imphal I

- 400 kV Silchar-Imphal Ckt I Tripped multiple times on 24/01/19, 25/01/19, 27/01/19 & 29/01/19.
- The incidents happened after synchronisation of line at 400kV without thorough patrolling & ensuring adequate RoW.
- Even after the first time charging on 26/01/19, the line tripped on 27/01/19 & 29/01/19.
- Both the trippings were “near miss” incidents for Manipur System
- Action plan from NERTS requested to avert future incidents
- Letter No NERLDC/SO-I/NERTS/2019/2571 is enclosed as [Annexure 13](#)

42

14. Simultaneous Tripping of 400 kV Bongaigaon – Byrnihat line and 400 kV Bongaigaon – Azara line on 29.01.19

- **List of simultaneous tripping of NETC lines during the past 2 years enclosed as [Annexure-14](#)**
- **Action plan from NETC is requested with root cause analysis to avert future incidents**

43

Black Start Restoration Procedure

- ❖ **Black start and resoration procedure for NER Region has been published and uploaded in NERLDC website (<http://nerlhc.in>) on 31st January, 2019.**
- ❖ **All Constituents are requested to go through the procedure and participate in mock drills, so that successful and speedy restoration is possible when need arises.**

Agenda 15. Tentative schedule for BSRP Mock exercise in NER during the year 2019

Agenda 16. Tentative schedule for BSRP workshop in NER

44

Agenda 17. RGMO Performance Analysis

Event :On 05th Feb 2019, at 11:57 Hrs load loss of approx. 869 MW occurred in Northern Region (Delhi-226 MW, Haryana -152 MW, Rajasthan- 400 MW, UP - 91 MW)

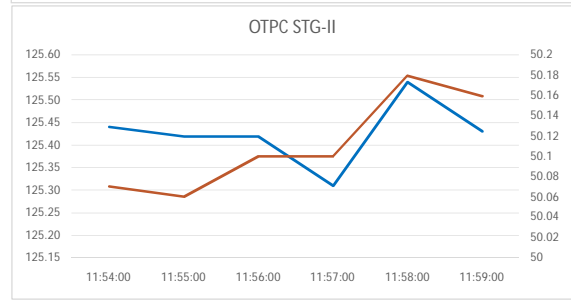
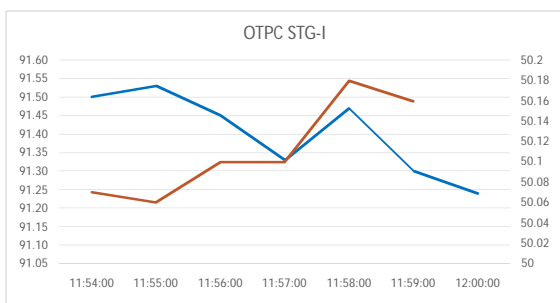
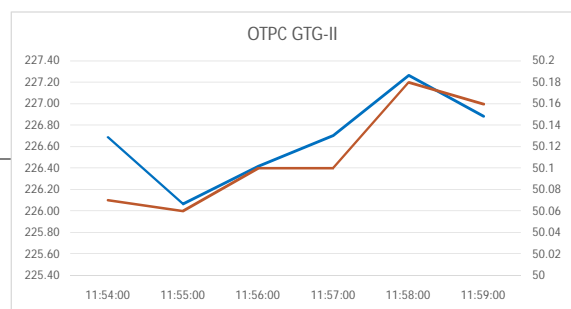
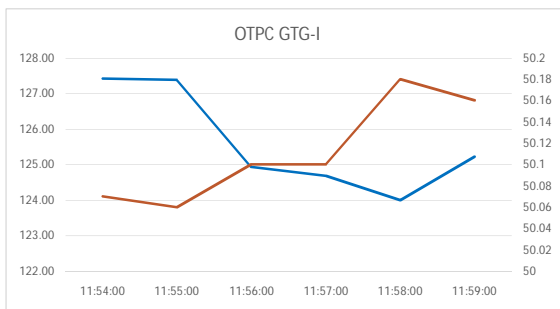
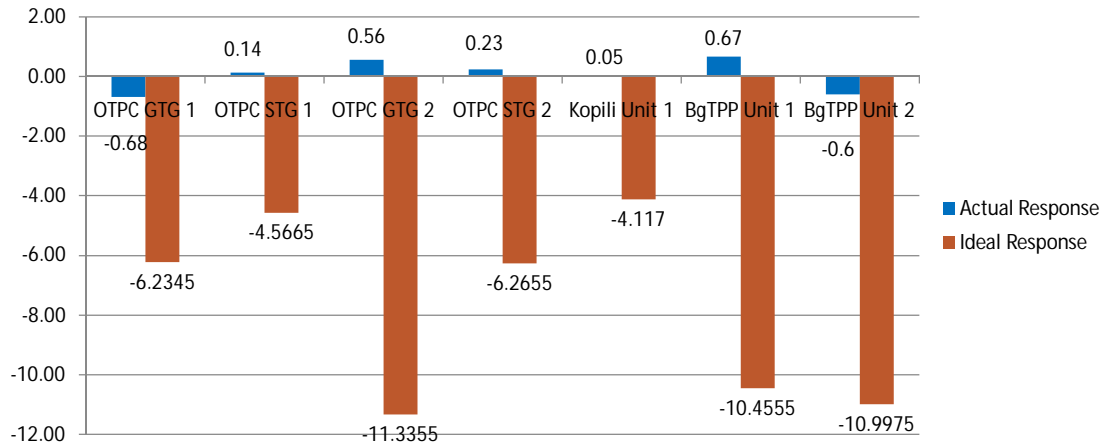

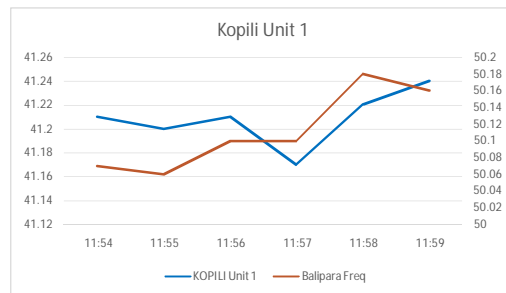
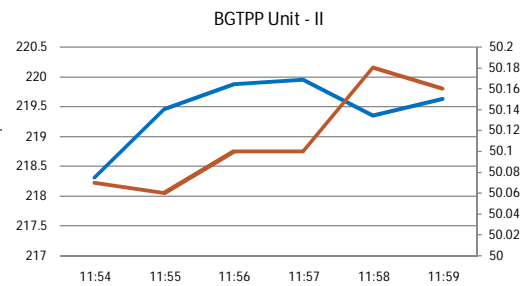
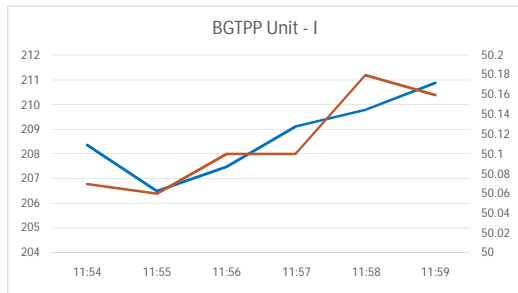

47

19. Furnishing technical parameters of the transmission element by CTU / STU in the standard format required for network modelling while requesting permission for first time charging

- Standard format has been prepared for furnishing of network modelling while requesting permission for first time charging.
- It is requested to submit these formats along with the other already approved formats.
- Format details are in [Annexure 19a](#) for Transmission Line, [Annexure 19b](#) for Reactor and [Annexure 19c](#) for ICT

48

20. Strict compliance of CERC approved schedule for seeking permission & submission of required data formats enabling RLDC / NLDC to accord permission on time for first time charging of elements

- It is requested to all the constituents to strictly comply with the CERC approved schedule as given in [Annexure 3b](#)
- Some of the non-compliances are shown in [Annexure 3c](#)
- Transmission Utilities are requested follow the approved procedure and to ensure the following points:
 - Submission of formats A1-A6 by Asset Owner with a request for charging of new element to NERLDC at least ten (10) days prior to the anticipated date of first test charging.
 - Submission of B1-B5 (format-III) by the asset owner at least three (3) days prior to the date of first time charging

49

20. Strict compliance of CERC approved schedule for seeking permission & submission of required data formats enabling RLDC / NLDC to accord permission on time for first time charging of elements

- **Some of the non-compliance:**

Sl No	Name of Elements	Date of Application	Date of Likely Charging	Difference in days between application and charging
1	400/220/33 kV, 315 MVA ICT# 2 at 400 kV Bongaigaon S/s, POWERGRID	06.09.18	06.09.18	0
2	400 kV, 125 MVAR Bus Reactor at Bongaigaon S/s	12.07.18	14.07.18	2
3	400/132 kV 315 MVA ICT 3 at Silchar S/s	26.06.18	28.06.18	2
4	400 kV, 125 MVAR Bus Reactor at Silchar S/s	17.12.18	17.12.18	0
5	245 kV, 31.5 MVAR Bus Reactor at Mokochung S/s	16.11.18	20.11.18	4
6	400 kV, 125 MVAR Bus Reactor 3 at Balipara S/s	23.07.18	25.07.18	2
7	315 MVA, 400/132/33 kV ICT 1 at Imphal Substation	08.01.19	10.01.19	2

50

21. Proposal for First Time Charging of elements of Intra State Transmission System

- It is requested to comply with these two requirements for first time charging of Intra State Transmission Systems:-
 - Approval from NERLDC as per format and schedule for elements of 400 kV & above voltage level
 - Submission of undertaking in respect of Protection System and Telemetry & Communication for elements of 132 kV & above voltage level

Agenda 22: Scada and communication Telemetry Availability Status at NERLDC from Constituents (as on 05-02-2019)

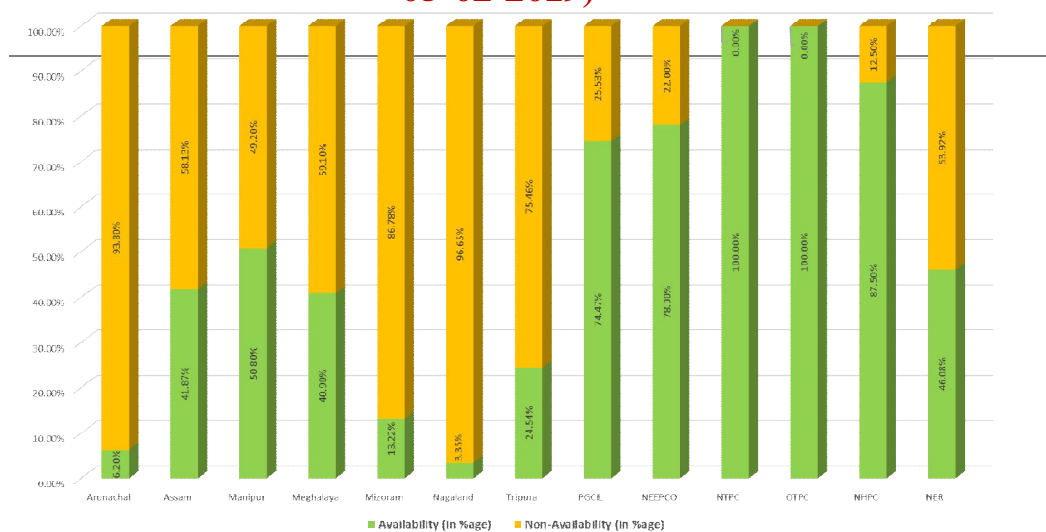

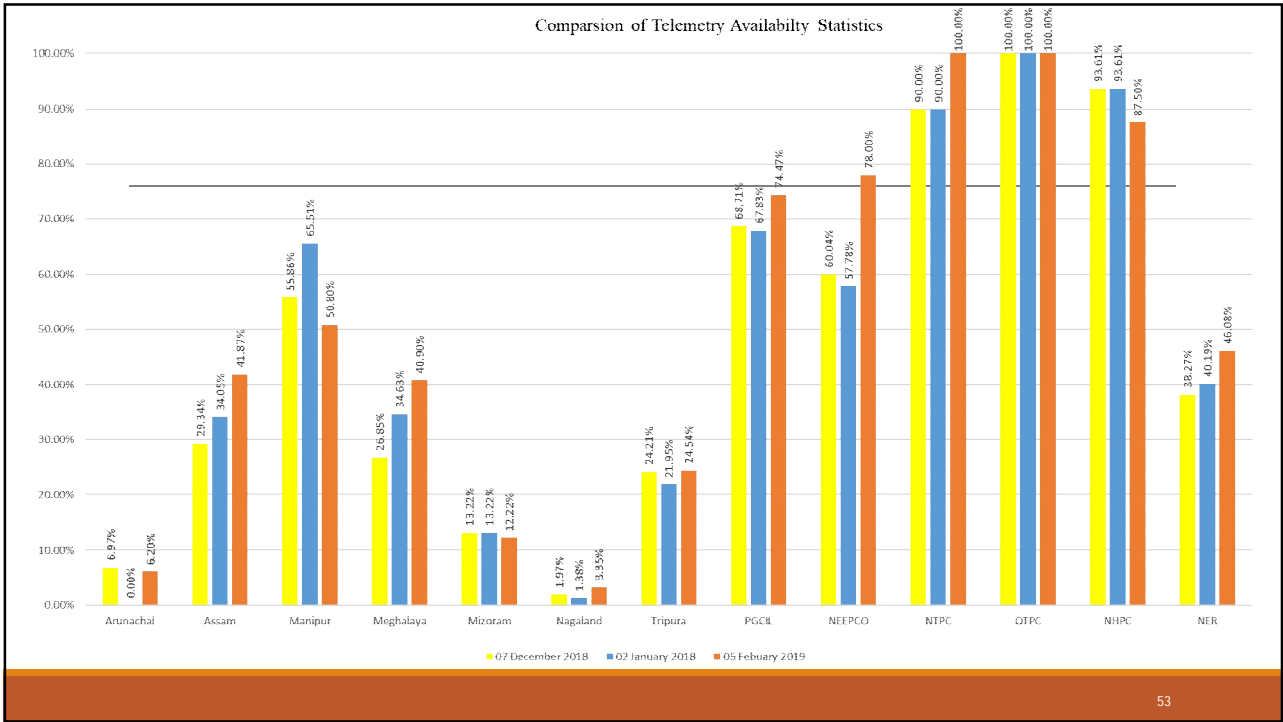

Metering & Meter Data

24. Non-Furnishing of weekly SEM data and Time Drift report

- List of locations enclosed as [Annexure-24](#)

55

25. Replacement of high time drift SEMs

- Location wise time drift details enclosed as [Annexure-25](#)
- Action : Respective Regional Entities

56

26. Rectification of SEM error / configuration at Panchgram & Karong 132 kV S/S

57

27. Status Review:

- a. Installation of TARA devices in Assam & Meghalaya
- b. Installation / Replacement of SEMs by NERTS
- c. Tendering of S/W for the additional Laptops (70 Nos)
- d. Procurement & Disbursement of DCDs by NERTS
- e. Spare SEM / DCDs procurement

58

Agenda: Other Issues

28. Bus Configuration changes of Critical Nodes for reliable operation of NER Power System

- For reliable operation of NER Power System, some critical nodes are shown in [Annexure 28](#)
- Action: Date for Joint meeting of NERTS, NERPC & NERLDC is requested

59

29. Assessment of TTC, TRM & ATC by SLDC

- It is requested to all the SLDCs to assessment of TTC, TRM & ATC on respective Inter-State Transmission Corridor
- It is requested to submit the assessment by 20.02.19.
- The figures obtained by NERLDC is shown in the right

State Wise TTC/Drawal Figures for 153rd OCCM				
States	Off Peak		Peak	
	N-0	N-1	N-0	N-1
Arunachal	254	224	254	224
Assam	1788	1638	1758	1608
Manipur	343	268	343	268
Meghalaya	270	200	249	153
Mizoram	132	120	132	120
Nagaland	204	189	204	189
Tripura (including Bangladesh)	278	88	299	131

60

30. Ratification of Technical and Commercial data for computation of PoC Charges and Losses for April to June'19 (Q1 of 2019-20)

- All SLDCs have submitted except Arunachal Pradesh
- The data for ratification is in [Annexure 7](#)

61

31. Accurate Load forecasting by SLDCs as per IEGC cl.5.3 for better system operation

- All the SLDCs are requested to improve the load forecast
- Letter from NERLDC on RMSE of load forecasting for the month of January 2019 enclosed as [Annexure-31](#)

% Error with Actual Data (Forecasted by States)							
	Arunachal Pradesh	Assam	Manipur	Meghalaya	Mizoram	Nagaland	Tripura
Median	16	6	7	10	32	12	8

62

32. Charging of 400 kV Silchar (PG) – Melriat (PG) I (Future) Main Bay for completing GIS Dia of 420 kV, 125 MVAR Bus Reactor at 400/132 kV Silchar Substation

- Approval from Standing Committee is to be taken by NERTS, POWERGRID regarding charging of 400 kV Silchar – Melriat D/C (GIS) along with associated bays

63

33. Updating the List of Important Grid Elements of NER

- As per inputs received from utilities, List of Important Grid Elements of NER is updated till 31st Dec'18
- All the Utilities are requested to update the excel file circulated vide email dated 06.02.19.
- **34. Implementation of Security Constrained Economic Dispatch (SCED) of Inter-State Generating Stations Pan-India on pilot basis w.e.f 01.04.2019 – Presentation by NERLDC**

(Ref: <http://cercind.gov.in/2019/orders/02-SM-2019.pdf>.)

35. Primary Response Testing:

64

Additional Agenda

MATLAB training at NERLDC, Shillong w.e.f 21st Feb'19 to 23rd Feb'19

65

Thank You

66

Annexure-D (Reactor)

TECHNICAL PARAMETERS OF REACTOR			
SN	Details	Unit	Value
1	Type of Reactor (Bus Reactor/ Line Reactor)		
2	Whether Three Phase Unit/ Single Phase Units/ Single Phase Unit with spare unit		
3	Whether Switchable or Convertible		
4	Whether Bus Reactor can be taken as Line Reactor	Yes/No	
5	Rating	MVAR	
6	Make		
7	Owner		
8	Rated System Voltage	kV	
9	Maximum Operating Voltage	kV	
10	Winding Connection (3 phase)	Star/Delta	
11	Type of Neutral Earthing	Whether NGR Connected/ Other	
12	NGR Rating		
13	Xo/X1 ratio		
14	Ambient Temperature	deg C	
15	Percentage Impedance		
	positive sequence	% R, % X	
	zero sequence	% R, % X	
16	Service	Outdoor/ Indoor	
17	Reactor Bushing	-	-
	Type	-	-
	HV	Eg. Oil Filled condenser/resin impregnated paper	
	Neutral		
	Rated Voltage		
	HV	kV	

	Neutral	kV	
	Rated Current		
	HV	A (which standard followed)	
	Neutral	A (which standard followed)	
18	Bushing CT	-	-
	No of Cores		
	Details of Cores	-	-
	Core 1	A	
	Core 2	A	
	Core 3 (if available)	A	
	Core 4 (if available)	A	

TECHNICAL PARAMETERS OF BUS BAR
--

SN	Details	Unit	Value
1	Substation Name	Name	
2	Voltage Level	kV	
3	Rated Capacity of the Bus	A	
4	Type of Bus Bar	(Al Pip or conductor etc)	
5	Bus Bar Scheme showing the element connected submitted	Yes/No	

TECHNICAL PARAMETERS OF SURGE ARRESTOR

SN	Details	Unit	Value
1	Make		
2	Rated System Voltage	kV	
3	Highest System Voltage	kV	
4	Rated Arrester Voltage	kV	
5	Continuous Operating Voltage (COV) at 50 deg C	kVrms	
6	Minimum Discharge Capability	kJ/kV	
7	Discharge Current (8/20 us wave):		
	Nominal Discharge current	kAp	
	Discharge Current at which insulation co-ordination will be done	kAp	

If the parameters for the three phases differ, please submit the information in multiple formats for different phases. Else, only one copy of this format is sufficient.

TECHNICAL PARAMETERS OF WAVE TRAP

SN	Details	Unit	Value
1	Type of Wave Trap	Outdoor/Indoor	
2	Type of Wave Trap	Post Insulator/CVT/Suspension Type	
3	Voltage Level		
4	Resistive Component of Impedance	Ohm	
5	Tolerable Short Circuit Current	kA	
	PLCC	-	-
6	Make		
7	Model		
8	No of Panels		
9	No of Codes		
10	Availability of Digital Protection Coupler		
11	Mode of Transmission		
12	No of Channels		
13	HF Channel	kHz	
14	Normal Continuous Current Rating	A	
15	Supply Voltage (DC)	V	

If the parameters for the three phases differ, please submit the information in multiple formats for different phases. Else, only one copy of this format is sufficient.

TECHNICAL PARAMETERS OF VOLTAGE TRANSFORMER

SN	Details	Unit	Value
1	Nominal/Rated Voltage	kV	
2	Highest System Voltage	kV	
3	Fault Current and Duration	kA and sec	
4	Cooling Mechanism		
5	Burden		
6	No of Cores	No	
7	CVT core details diagram marking the metering and protection details used.	Whether Submitted (Yes/No)	
8	Rated Primary Voltage	kV	
9	Rated Secondary Voltage	V	
10	Accuracy Class		
	:- Protection		
	:- Metering		
	:- Any Other		
11	Rated Capacitance	pF	
12	No of CVTs	Whether in every phase or two or one	
13	Rated Voltage Factor		
	:- continuous		
	:- for 30 seconds		

If the parameters for the three phases differ, please submit the information in multiple formats for different phases. Else, only one copy of this format is sufficient.

TECHNICAL PARAMETERS OF CURRENT TRANSFORMER
--

SN	Details	Unit	Value
1	Nominal/Rated Voltage	kV	
2	Highest System Voltage	kV	
3	No of Cores	Nos	
4	Cooling Mechanism		
5	Burden		
6	Rated Primary Current	A	
7	CT core details diagram marking the metering and protection details used.	Whether Submitted (Yes/No)	
8	Rated Transformation Ratio Used	-	-
9a	Protection	-	-
	Bus Differential	A	
	Other Protection Details	A	
	Other Protection Details	A	
	Other Protection Details	A	
	Other Protection Details	A	
	Other Protection Details	A	
9b	Metering	A	
10	Rated Fault current & its duration	kA	
11	Rated dynamic short circuit current	kAp	
12	Available CT Ratio		
13	Rated CT Ratio		

If the parameters for the three phases differ, please submit the information in multiple formats for different phases. Else, only one copy of this format is sufficient.

TECHNICAL PARAMETERS OF CIRCUIT BREAKER

SN	Details	Unit	Value
1	Nominal/Rated Voltage	kV	
2	Rated Current	A	
4	Operating Mechanism	Whether Pneumatic/ Spring/ hydraulic or its combination	
5	Quenching Medium		
5	Rated Fault current & its duration	kA & sec	
6	Rated short circuit making current	kAp	
7	No of Trip Coils		
8	No of Sources for Trip Coils		
9	Rated Operating duty cycle:		
	for auto-reclosing type	Eg: O-0.3 sec- CO- 3 min- CO	
	for non-auto reclosing type	Eg: O-0.3 sec- CO- 3 min- CO	
	for non-auto reclosing type (Generator Transformer CB of hydro projects)	Eg: O-0.3 sec- CO- 3 min- CO	
10	Auto Reclose	Single Phase/ Three Phase	
11	Whether ganged operated or single phase operation		
12	PIR Details		

If the parameters for the three phases differ, please submit the information in multiple formats for different phases. Else, only one copy of this format is sufficient.

TECHNICAL PARAMETERS OF DISCONNECTOR AND EARTH SWITCHES			
--	--	--	--

SN	Details	Unit	Value
1	Nominal/Rated Voltage	kV	
2	Highest System Voltage	kV	
3	Rated Current	A	
4	Operating Mechanism	Eg: AC motor operated & manual	
5	Rated Fault current & its duration	kA	
6	Rated short circuit making current	kAp	
7	Operating Time	Sec	
8	DC Control Voltage	V	

If the parameters for the three phases differ, please submit the information in multiple formats for different phases. Else, only one copy of this format is sufficient.

PROTECTION DATA OF REACTOR

SN	Details	Unit	Value
1	Whether Manual Trigger DR and EL outputs (cfg and dat file) of the numerical relays and of other relays (if download possible) for the element submitted.	Yes/No	
2	List of DR Channels and EL Channels configured.		
3	Standalone/In-built in relay		
4	Standalone/Configured in BCU or SCADA		
<i>Electrical Protection</i>			
5	Differential Relay		
	Type		
	Model		
	Make		
6	REF		
	Type		
	Model		
	Make		
7	Over Current		
	Type		
	Model		
	Make		
	TMS		
	PSM		
	Operating Curve Type		
8	Earth Fault		
	Type		
	Model		

	Make		
	TMS		
	PSM		
	Operating Curve Type		
9	TEED		
	Type		
	Model		
	Make		
10	Back up Impedance		
	Type		
	Model		
	Make		
	<i>Mechanical Protection</i>		
11	Buchholz		
	Alarm		
	Trip		
12	WTI		
	Temperature Settings for Alarm		
	Temperature Settings for Trip		
13	OTI		
	Temperature Settings for Alarm		
	Temperature Settings for Trip		
14	PRD		
	Make		
	Model		
	Operating Pressure		
15	LBB		
	Type		
	Model		
	Make		

16	Any Other Protection Details		
17	Time Sync of Relay	Yes/No	
18	Controlled Switching Device (CSD)	Yes/No	
19	Master Trip and Auxiliary Trip Relay Details		

Annexure-D (Transformer)

TECHNICAL PARAMETERS OF TRANSFORMER			
SN	Details	Unit	Value
1	Rating (HV/IV/LV)	MVA	
2	Single phase/ Three Phase Units		
3	Type of Cooling		
4	Rating at different cooling	%	
5	Voltage Ratio	kV	
6	Vector Group		
7	Percentage Impedance		
	positive sequence		
	HV and IV	% R, % X	
	HV and LV	% R, % X	
	IV and LV	% R, % X	
	zero sequence		
	HV and IV	% R, % X	
	HV and LV	% R, % X	
	IV and LV	% R, % X	
8	Service	Outdoor/Indoor	
9	Over load Capacity	Which standard followed	
10	Ambient Temperature	Deg Celsius	
11	Winding Connection		
	HV	Star/Delta	
	IV	Star/Delta	
	LV	Star/Delta	
12	Neutral Connection		
	HV	Grounded/ Ungrounded	
	IV	Grounded/ Ungrounded	
	LV	Grounded/ Ungrounded	
13	Transformer Bushing	-	-
	Type	-	-
	HV	Eg. Oil Filled	

	IV	condenser/resin impregnated paper	
	Neutral		
	LV		
14	Rated Voltage		
	HV	kV	
	IV	kV	
	Neutral	kV	
	LV	kV	
15	Rated Current		
	HV	A (which standard followed)	
	IV	A (which standard followed)	
	LV	A (which standard followed)	
16	Bushing CT	-	-
	No of Cores		
	Details of Cores	-	-
	Core 1	A	
	Core 2	A	
	Core 3 (if available)	A	
	Core 4 (if available)	A	
17	Tap Details		
	Type of Tap Changer	On Load/Off Load	
	% change per step	%	
	No of Taps	No	

TECHNICAL PARAMETERS OF BUS BAR
--

SN	Details	Unit	Value
1	Substation Name	Name	
2	Voltage Level	kV	
3	Rated Capacity of the Bus	A	
4	Type of Bus Bar	(Al Pip or conductor etc)	
5	Bus Bar Scheme showing the element connected submitted	Yes/No	

TECHNICAL PARAMETERS OF SURGE ARRESTOR

SN	Details	Unit	Value
1	Make		
2	Rated System Voltage	kV	
3	Highest System Voltage	kV	
4	Rated Arrester Voltage	kV	
5	Continuous Operating Voltage (COV) at 50 deg C	kVrms	
6	Minimum Discharge Capability	kJ/kV	
7	Discharge Current (8/20 us wave):		
	Nominal Discharge current	kAp	
	Discharge Current at which insulation co-ordination will be done	kAp	

If the parameters for the three phases differ, please submit the information in multiple formats for different phases. Else, only one copy of this format is sufficient.

TECHNICAL PARAMETERS OF WAVE TRAP

SN	Details	Unit	Value
1	Type of Wave Trap	Outdoor/Indoor	
2	Type of Wave Trap	Post Insulator/CVT/Suspension Type	
3	Voltage Level		
4	Resistive Component of Impedance	Ohm	
5	Tolerable Short Circuit Current	kA	
	PLCC	-	-
6	Make		
7	Model		
8	No of Panels		
9	No of Codes		
10	Availability of Digital Protection Coupler		
11	Mode of Transmission		
12	No of Channels		
13	HF Channel	kHz	
14	Normal Continuous Current Rating	A	
15	Supply Voltage (DC)	V	

If the parameters for the three phases differ, please submit the information in multiple formats for different phases. Else, only one copy of this format is sufficient.

TECHNICAL PARAMETERS OF VOLTAGE TRANSFORMER

SN	Details	Unit	Value
1	Nominal/Rated Voltage	kV	
2	Highest System Voltage	kV	
3	Fault Current and Duration	kA and sec	
4	Cooling Mechanism		
5	Burden		
6	No of Cores	No	
7	CVT core details diagram marking the metering and protection details used.	Whether Submitted (Yes/No)	
8	Rated Primary Voltage	kV	
9	Rated Secondary Voltage	V	
10	Accuracy Class		
	:- Protection		
	:- Metering		
	:- Any Other		
11	Rated Capacitance	pF	
12	No of CVTs	Whether in every phase or two or one	
13	Rated Voltage Factor		
	:- continuous		
	:- for 30 seconds		

If the parameters for the three phases differ, please submit the information in multiple formats for different phases. Else, only one copy of this format is sufficient.

TECHNICAL PARAMETERS OF CURRENT TRANSFORMER
--

SN	Details	Unit	Value
1	Nominal/Rated Voltage	kV	
2	Highest System Voltage	kV	
3	No of Cores	Nos	
4	Cooling Mechanism		
5	Burden		
6	Rated Primary Current	A	
7	CT core details diagram marking the metering and protection details used.	Whether Submitted (Yes/No)	
8	Rated Transformation Ratio Used	-	-
9a	Protection	-	-
	Bus Differential	A	
	Other Protection Details	A	
	Other Protection Details	A	
	Other Protection Details	A	
	Other Protection Details	A	
	Other Protection Details	A	
9b	Metering	A	
10	Rated Fault current & its duration	kA	
11	Rated dynamic short circuit current	kAp	
12	Available CT Ratio		
13	Rated CT Ratio		

If the parameters for the three phases differ, please submit the information in multiple formats for different phases. Else, only one copy of this format is sufficient.

TECHNICAL PARAMETERS OF CIRCUIT BREAKER

SN	Details	Unit	Value
1	Nominal/Rated Voltage	kV	
2	Rated Current	A	
4	Operating Mechanism	Whether Pneumatic/ Spring/ hydraulic or its combination	
5	Quenching Medium		
5	Rated Fault current & its duration	kA & sec	
6	Rated short circuit making current	kAp	
7	No of Trip Coils		
8	No of Sources for Trip Coils		
9	Rated Operating duty cycle:		
	for auto-reclosing type	Eg: O-0.3 sec- CO- 3 min- CO	
	for non-auto reclosing type	Eg: O-0.3 sec- CO- 3 min- CO	
	for non-auto reclosing type (Generator Transformer CB of hydro projects)	Eg: O-0.3 sec- CO- 3 min- CO	
10	Auto Reclose	Single Phase/ Three Phase	
11	Whether ganged operated or single phase operation		
12	PIR Details		

If the parameters for the three phases differ, please submit the information in multiple formats for different phases. Else, only one copy of this format is sufficient.

TECHNICAL PARAMETERS OF DISCONNECTOR AND EARTH SWITCHES
--

SN	Details	Unit	Value
1	Nominal/Rated Voltage	kV	
2	Highest System Voltage	kV	
3	Rated Current	A	
4	Operating Mechanism	Eg: AC motor operated & manual	
5	Rated Fault current & its duration	kA	
6	Rated short circuit making current	kAp	
7	Operating Time	Sec	
8	DC Control Voltage	V	

If the parameters for the three phases differ, please submit the information in multiple formats for different phases. Else, only one copy of this format is sufficient.

PROTECTION DATA OF TRANSFORMER			
SN	Details	Unit	Value
1	Whether Manual Trigger DR and EL outputs (cfg and dat file) of the numerical relays and of other relays (if download possible) for the element submitted.	Yes/No	
2	List of DR Channels and EL Channels configured		
3	Standalone/In-built in relay		
4	Standalone/Configured in BCU or SCADA		
	<i>Electrical Protection</i>		
5	Differential Relay		
	Type		
	Model		
	Make		
6	REF		
	Type		
	Model		
	Make		
7	Overflow		
	Type		
	Model		
	Make		
8	LBB		
	Type		
	Model		
	Make		
9	Directional Over -Current (HV side)		
	Type		
	Model		

	Make		
	TMS		
	PMS		
	Operating Curve		
10	Directional Over -Current (LV side)		
	Type		
	Model		
	Make		
	TMS		
	PMS		
	Operating Curve		
11	Directional Earth Fault (HV side)		
	Type		
	Model		
	Make		
	TMS		
	PMS		
	Operating Curve		
12	Directional Earth Fault (LV side)		
	Type		
	Model		
	Make		
	TMS		
	PMS		
	Operating Curve		
13	Back up Impedance		
	Type		
	Model		
	Make		
	<i>Mechanical Protection</i>		

14	Buchholz		
	Alarm		
	Trip		
15	WTI		
	Temperature Settings for Alarm		
	Temperature Settings for Trip		
16	OTI		
	Temperature Settings for Alarm		
	Temperature Settings for Trip		
17	OSR		
	Alarm		
	Trip		
18	PRD		
	Model		
	Make		
	Operating pressure		
19	MOG(Low oil level alarm)		
20	Overload Alarm		
21	Any Other Protection Details		
22	Time Sync of Relay	Yes/No	
23	Controlled Switching Device (CSD)	Yes/No	
24	Installation of Online DGA	Yes/No	

Annexure-D (Transmission Line)

TECHNICAL PARAMETERS OF LINE			
SN	Details	Unit	Value
1	From Substation	Name	
2	To Substation	Name	
3	Voltage Level	kV	
4	Line Length	km	
5	Type of conductor Used		
6	No of Sub conductors	No	
7	Type of Insulator		
8	Positive Sequence		
	R (Resistance)	ohm/km	
	X (Reactance)	ohm/km	
	B (Susceptance)	mho/km	
9	Zero Sequence		
	R (Resistance)	ohm/km	
	X (Reactance)	ohm/km	
	B (Susceptance)	mho/km	
10	Ampacity	A	
11	Temperature related Ampacity Values, if available	A & Temp	
		A & Temp	
		A & Temp	
		A & Temp	
12	Transposition Details		
	No of Transposition Towers in the line	No	
	Distance of the Transposition Towers from From End	location nos, km	
13	Dropper from Line to Bus Details		
	Sending End Name	Name	
	Type of conductor used	Type	
	No of conductors	No	
	Capacity	A	
	To Substation	Name	

	Type of conductor used	Type	
	No of conductors	No	
	Capacity	A	

TECHNICAL PARAMETERS OF BUS BAR
--

SN	Details	Unit	Value
1	Substation Name	Name	
2	Voltage Level	kV	
3	Rated Capacity of the Bus	A	
4	Type of Bus Bar	(Al Pip or conductor etc)	
5	Bus Bar Scheme showing the element connected submitted	Yes/No	

TECHNICAL PARAMETERS OF SURGE ARRESTOR

SN	Details	Unit	Value
1	Make		
2	Rated System Voltage	kV	
3	Highest System Voltage	kV	
4	Rated Arrester Voltage	kV	
5	Continuous Operating Voltage (COV) at 50 deg C	kVrms	
6	Minimum Discharge Capability	kJ/kV	
7	Discharge Current (8/20 us wave):		
	Nominal Discharge current	kAp	
	Discharge Current at which insulation co-ordination will be done	kAp	

If the parameters for the three phases differ, please submit the information in multiple formats for different phases. Else, only one copy of this format is sufficient.

TECHNICAL PARAMETERS OF WAVE TRAP

SN	Details	Unit	Value
1	Type of Wave Trap	Outdoor/Indoor	
2	Type of Wave Trap	Post Insulator/CVT/Suspension Type	
3	Voltage Level		
4	Resistive Component of Impedance	Ohm	
5	Tolerable Short Circuit Current	kA	
	PLCC	-	-
6	Make		
7	Model		
8	No of Panels		
9	No of Codes		
10	Availability of Digital Protection Coupler		
11	Mode of Transmission		
12	No of Channels		
13	HF Channel	kHz	
14	Normal Continuous Current Rating	A	
15	Supply Voltage (DC)	V	

If the parameters for the three phases differ, please submit the information in multiple formats for different phases. Else, only one copy of this format is sufficient.

TECHNICAL PARAMETERS OF VOLTAGE TRANSFORMER

SN	Details	Unit	Value
1	Nominal/Rated Voltage	kV	
2	Highest System Voltage	kV	
3	Fault Current and Duration	kA and sec	
4	Cooling Mechanism		
5	Burden		
6	No of Cores	No	
7	CVT core details diagram marking the metering and protection details used.	Whether Submitted (Yes/No)	
8	Rated Primary Voltage	kV	
9	Rated Secondary Voltage	V	
10	Accuracy Class		
	:- Protection		
	:- Metering		
	:- Any Other		
11	Rated Capacitance	pF	
12	No of CVTs	Whether in every phase or two or one	
13	Rated Voltage Factor		
	:- continuous		
	:- for 30 seconds		

If the parameters for the three phases differ, please submit the information in multiple formats for different phases. Else, only one copy of this format is sufficient.

TECHNICAL PARAMETERS OF CURRENT TRANSFORMER
--

SN	Details	Unit	Value
1	Nominal/Rated Voltage	kV	
2	Highest System Voltage	kV	
3	No of Cores	Nos	
4	Cooling Mechanism		
5	Burden		
6	Rated Primary Current	A	
7	CT core details diagram marking the metering and protection details used.	Whether Submitted (Yes/No)	
8	Rated Transformation Ratio Used	-	-
9a	Protection	-	-
	Bus Differential	A	
	Other Protection Details	A	
	Other Protection Details	A	
	Other Protection Details	A	
	Other Protection Details	A	
	Other Protection Details	A	
9b	Metering	A	
10	Rated Fault current & its duration	kA	
11	Rated dynamic short circuit current	kAp	
12	Available CT Ratio		
13	Rated CT Ratio		

If the parameters for the three phases differ, please submit the information in multiple formats for different phases. Else, only one copy of this format is sufficient.

TECHNICAL PARAMETERS OF CIRCUIT BREAKER

SN	Details	Unit	Value
1	Nominal/Rated Voltage	kV	
2	Rated Current	A	
4	Operating Mechanism	Whether Pneumatic/ Spring/ hydraulic or its combination	
5	Quenching Medium		
5	Rated Fault current & its duration	kA & sec	
6	Rated short circuit making current	kAp	
7	No of Trip Coils		
8	No of Sources for Trip Coils		
9	Rated Operating duty cycle:		
	for auto-reclosing type	Eg: O-0.3 sec- CO- 3 min- CO	
	for non-auto reclosing type	Eg: O-0.3 sec- CO- 3 min- CO	
	for non-auto reclosing type (Generator Transformer CB of hydro projects)	Eg: O-0.3 sec- CO- 3 min- CO	
10	Auto Reclose	Single Phase/ Three Phase	
11	Whether ganged operated or single phase operation		
12	PIR Details		

If the parameters for the three phases differ, please submit the information in multiple formats for different phases. Else, only one copy of this format is sufficient.

TECHNICAL PARAMETERS OF DISCONNECTOR AND EARTH SWITCHES			
--	--	--	--

SN	Details	Unit	Value
1	Nominal/Rated Voltage	kV	
2	Highest System Voltage	kV	
3	Rated Current	A	
4	Operating Mechanism	Eg: AC motor operated & manual	
5	Rated Fault current & its duration	kA	
6	Rated short circuit making current	kAp	
7	Operating Time	Sec	
8	DC Control Voltage	V	

If the parameters for the three phases differ, please submit the information in multiple formats for different phases. Else, only one copy of this format is sufficient.

PROTECTION DATA OF TRANSMISSION LINE			
SN	Details	Unit	Value
1	Whether Manual Trigger DR and EL outputs (cfg and dat file) of the numerical relays and of other relays (if download possible) for the element submitted.	Yes/No	
2	List of DR Channels and EL Channels configured		
3	Standalone/In-built in relay		
4	Standalone/Configured in BCU or SCADA		
5	Installation of TLSA	Yes/No, If Yes, Location	
6	Line Differential Protection	-	-
	Available	Yes/No	
	Make		
	Model		
7	Main I Protection	-	-
	Type	Numerical/ EM/ Static	
	Make		
	Model		
	Whether DEF enabled	Yes/No	
8	Main II Protection	-	-
	Type	Numerical/ EM/ Static	
	Make		
	Model		
	Whether DEF enabled	Yes/No	
9	Over Voltage Stage I	-	-
	External Relay/Enabled in (Main-I / Main-II) or both Main-I & Main-II		
	Type	Numerical/ EM/ Static	
	Make		
	Model		
	Settings	Voltage and Time	

10	Over Voltage Stage II	-	-
	External Relay/Enabled in (Main-I / Main-II) or both Main-I & Main-II		
	Type	Numerical/ EM/ Static	
	Make		
	Model		
	Settings	Voltage and Time	
11	Direct Trip	-	-
	Handtrip	(Yes/No)	
	LBB	(Yes/No)	
	DEF	(Yes/No)	
	Reactor protection	(Yes/No)	
	Over-voltage	(Yes/No)	
	Busbar	(Yes/No)	
12	Carrier Aided Trip	-	-
	Availability	(Yes/No)	
	POR/PUR		
13	Over Current	-	-
	Type		
	Model		
	Make		
	TMS		
	PMS		
	Operating Curve Type		
14	Earth Fault	-	-
	Type		
	Model		
	Make		
	TMS		
	PMS		
	Operating Curve Types		
15	Broken Conductor Alarm	Yes/No	
16	Stub protection	(Yes/No/NA)	
17	TEED Protection	(Yes/No)	
	Type		
	Model		
	Make		
18	DEF	-	-
	Type		
	Model		
	Make		

19	LBB	-	-
	Type		
	Model		
	Make		
	Setting		
20	Check Synchronisation/ Dead Line Charging	Yes /No	
21	Time Sync of Relay	Yes/ No	
22	Fault Locator		
23	DR		
	Installed	Yes/ No	
	Activated	Yes/ No	
	Standardised	Yes/ No	
	No of Digital Channels Assigned		
24	EL		
	Installed	Yes/ No	
	Activated	Yes/ No	
	Standardised	Yes/ No	
25	Any Other Protection Details		

Procurement of Web Based Protection Database Management Software and Protection Setting Calculation Tool for North Eastern Region



सत्यमेव जयते

North Eastern Regional Power Committee

NERPC Complex, Dong Parmaw, Lapalang, Shillong – 793006

OPERATIONAL LOAD FLOW STUDIES UNDER WINTER OFF PEAK LOADING CONDITIONS

January 2019



**Power Research and Development Consultants
Private Limited**

5, 11th cross, 2nd stage, west of chord road,

Bangalore - 560 086, Karnataka

Tel: +91- 80-23192159 / 23192168

E-mail – prdc@vsnl.com

Web site: www.prdcinfotech.com

Document reference details:

LOA No : NERPC/SE(O)/PDMS/2018/4135

Document Reference No : PRDC/2018-2019/NERPC/1439

Revision Index

Revision	Description	Date	Remarks
R0	Winter-Off peak Load Flow Report	21.01.2019	Initial version

Internal Approval

Prepared by	Mr. Sanjit Guhathakurta	21.01.2019	
	Mr. Anirban Banerjee		
	Ms. Suman Kumari		
Reviewed by	Mrs. Debarati Basu	22.01.2019	
	Mr. Debabrata Paul	23.01.2019	
Approved by	Mrs. Debarati Basu	24.01.2019	

TABLE OF CONTENTS

1	INTRODUCTION	11
2	PROJECT SCOPE	12
2.1	Database Building Activities for Operational Studies.....	12
3	SYSTEM OPERATIONAL DATA	14
3.1	Methodology adopted for performing the load flow analysis	16
3.1.1	Data Collection Procedure.....	16
3.2	December 19, 2018 Off-peak system demand condition	18
3.3	Salient points of CEA planning criteria referred for system analysis	18
3.3.1	Transmission line parameters	18
3.4	Transformer parameters	20
3.4.1	Voltage limits	20
3.5	Network element statistics for NER Grid.....	20
3.5.1	Substation details.....	20
3.5.2	Transmission line details	21
3.5.3	Transformer details.....	21
3.5.4	Generation details.....	21
3.5.5	HVDC details	22
3.5.6	Reactor details	22
3.5.7	Load details	23
3.6	Generation schedule details for operational load flow	24
4	OPERATIONAL LOAD FLOW STUDY	25
4.1	Introduction to Load flow analysis.....	25
4.2	Load Generation Balance from the results of operational load flow analysis	27
4.3	Line loading conditions	31
4.4	Transformer loading conditions	33
4.5	Voltage profile	35
4.6	Synopsis of Load Flow Study Results.....	40
5	SHORT CIRCUIT STUDIES	41
5.1	Short circuit study result analysis.....	42
6	MAJOR OBSERVATIONS & CONCLUSION	43

LIST OF FIGURES

Figure 3.1: Constituents of North Eastern Regional grid 15
Figure 3.2: Scheduled generation, Import and Export of North Eastern Regional grid 25
Figure 4.1: Block diagram of load generation balance of NER 30

LIST OF TABLES

Table 3.1: Data availability status	16
Table 3.2: NER loading details.....	18
Table 3.3: Source of the data considered for the study.....	18
Table 3.4: Details of transmission line parameters.....	19
Table 3.5: Details of transformer parameters	20
Table 3.6: Voltage limits at different voltage levels prescribed in CEA’s “Transmission.. Planning Criteria”	20
Table 3.7: Existing number of sub-station in the NER.....	20
Table 3.8: Summary of transmission line data in the NER	21
Table 3.9: Summary of transformers capacity in the NER.....	21
Table 3.10: Summary of Generator installed capacity in the NER	22
Table 3.11: HVDC BI Pole in the NER.....	22
Table 3.12: HVDC Link in the NER	22
Table 3.13: Substation wise total reactive power compensation details	23
Table 3.14: Load Details of NER	23
Table 3.15: Generation schedule Details of NER.....	24
Table 4.1: Load generation balance Details of NER	27
Table 4.2: Load generation balance details of Arunachal Pradesh.....	27
Table 4.3: Load generation balance details of Assam	28
Table 4.4: Load generation balance details of Manipur	28
Table 4.5: Load generation balance details of Meghalaya	28
Table 4.6: Load generation balance details of Mizoram	28
Table 4.7: Load generation balance details of Nagaland.....	29
Table 4.8: Load generation balance details of Tripura	29
Table 4.09: Percentage loading details of lines of North Eastern Region	31
Table 4.10: Percentage loading details of lines of Arunachal Pradesh.....	31
Table 4.11: Percentage loading details of lines of Assam	31
Table 4.12: Percentage loading details of lines of Manipur	31
Table 4.13: Percentage loading details of lines of Meghalaya	32
Table 4.14: Percentage loading details of lines of Mizoram	32
Table 4.15: Percentage loading details of lines of Nagaland.....	32
Table 4.16: Percentage loading details of lines of Tripura.....	32
Table 4.17: Percentage loading details of Transformers of North Eastern Region	33
Table 4.18: Percentage loading details of Transformers of Arunachal Pradesh.....	33
Table 4.19: Percentage loading details of Transformers of Assam	33
Table 4.20: Percentage loading details of Transformers of Manipur	34
Table 4.21: Percentage loading details of Transformers of Meghalaya	34
Table 4.22: Percentage loading details of Transformers of Mizoram	34
Table 4.23: Percentage loading details of Transformers of Nagaland.....	35
Table 4.24: Percentage loading details of Transformers of Tripura.....	35
Table 4.25: Bus Voltage Profile for North Eastern Region.....	35
Table 4.26: 400 kV and 220 kV Bus Voltage of North Eastern Region grid	36

EXECUTIVE SUMMARY

In the recent past, it has been noted that most of the grid collapses have been attributed to protection system failure or mal functioning. The reports on the North American blackout (August 2003) and the more recent Indian grid collapse (July 2012) have all emphasized the need for “Protection Management System”.

As a recommendation of the Enquiry Committee headed by Chairperson CEA on grid disturbances in NEW grid on 30th and 31st July 2012, Ministry of Power constituted a Task Force on Power System Analysis under Contingencies” in December 2012.

The task force recommends creation and maintenance of protection database under RPCs. Accordingly, Secretary (Power) in a meeting in Ministry of Power held on 11.03.14 directed all RPCs to implement the recommendations of the report submitted by “Task Force” in a time bound manner.

Following the decision of Ministry of Power NERPC secretariat has taken up a project of **“Procurement of Web Based Protection Database Management Software and Protection Setting Calculation Tool for North Eastern Region”**.

M/s PRDC has been awarded with the order by NERPC to implement the project in its entirety including creation of database and supply of software and hardware along with necessary power system analysis relevant for the project.

North Eastern Regional Grid comprises of the electrical system of the states of Arunachal Pradesh, Assam, Manipur, Meghalaya, Mizoram, Nagaland and Tripura under different transmission utilities. The major constituents of NER grid are the Transmission and Distribution Utilities of States and Central Transmission Utility, along with Generating Companies such as State, Central and Private sector. The NER covers a geographical area of 2,62,230 sq. km with an installed capacity of 3539.38 MW. In addition to this the region has an installed capacity of 104.95 MW in the form of CPP’s.

North Eastern Regional Power Committee (NERPC) formed by Ministry of Power is entrusted for facilitating the integrated operation of the power system in the region.

As a prerequisite of building the protection management system the first step as envisaged is the electrical modeling of the entire network data under NER system from 400 kV to 66 kV and carrying out the base case operational load flow analysis and short circuit studies for winter off peak load conditions.

The winter off peak scenario of NER grid is studied for Load flow and Short Circuit analysis. The data and electrical parameters of the EHV network elements, as

updated till 31st December 2018 by collecting data from the respective constituents of NER grid and updated network is modeled in power system analysis software MiP-PSCT.

It was decided in the 151st OCC meeting that the operational Load Flow study for NER grid has to be carried out for a load generation condition during winter off peak condition on an updated network data till December 2018. Load generation data is collected for 19th December 2018 at 19:00 hours as per the scenario given by NERLDC.

Load flow analysis and short circuit studies are conducted under winter off peak loading scenario and the observations on the results are detailed in subsequent sections of the report. State wise demand for NER grid is presented below.

Summarized particulars of network data for NER as on 30th December 2018 collected during the studies are given below:

Sl. No.	State	Demand (MW)
1.	Arunachal Pradesh	105
2.	Assam	1363
3.	Manipur	169
4.	Meghalaya	327
5.	Mizoram	86
6.	Nagaland	125
7.	Tripura	213

EHV Transmission Grid Substations: The total count is 174 with a voltage grade wise population mix as,

- 800 kV HVDC: Number of substation is 1 (Power Rating 3000 MW)
- 400 kV: Number of substation is 7 with an installed capacity of 4590 MVA
- 220 kV: Number of substation is 14 with an installed capacity of 3119.5 MVA
- 132 kV: Number of substation is 131 with an installed capacity of 5586.5 MVA
- 66 kV: Number of substation is 22 with an installed capacity of 271.9 MVA

NER generating units under state and central sector: Aggregated generation capacity of 3539.38 MW for which details are given as,

- Total number of hydro generating units is 54 with an installed capacity of 1461 MW
- Total number of thermal generating units is 12 with an installed capacity of 972.02 MW
- Total number of gas based generating units is 24 with an installed capacity of 1106.36 MW

CPP generation capacity: 104.95 MW.

Total EHV and HV Transmission Lines (66 kV and above): 18309.435 ckm (HDVC Link not considered)

The node wise load and generation data recorded are collected from the respective system owners and matched with the demand, generation and exchange recorded by SCADA of NERLDC for the selected time instant.

The consolidated observations from load flow analysis are:

Load Generation Balance Off-Peak Scenario:

Sl. No.	Description	Quantity (MW)
1	Generation	2684.94
2	Import	465.00
3	Total generation	3149.94
4	Loss	98.55
5	% Loss	3.12
6	Export	663.40
7	Load	2387.99
8	Total Load	3051.39
Total Demand		3149.94

Generation Scheduling: Generators are scheduled as per SCADA records of NERLDC.

Voltage Profile: From the off peak load flow analysis results, it is observed that the 400 & 220 kV bus voltages of the NER grid are on the higher side of the stipulated grid code.

- Due to under loading of transmission lines, maximum voltage observed at 400 kV and 220kV are 1.029 (Palatana) and 1.05 (Mariani PG) respectively.

Transformer loading:

- In the entire region, overloading of 4 transformers is observed. 36 no. of transformer loaded beyond 80% and 79 numbers are loaded below 20% of rated capacity which is predominantly in 132kV voltage level.

Line loading:

- No overloading is observed in any of the voltage grades.
- Number of lines loaded between 80 to 100% of their thermal capacity is 5 predominantly in 132 kV level. Numbers of lines loaded below 5% of thermal capacities are 5 at 220 kV level and 41 at 132 kV level.

Short Circuit studies are conducted on the network topology and generation scheduling of the load flow modeling for both three phase symmetrical faults and single line to ground fault conditions at every bus up to 33 & 11 kV voltage level by considering sub transient reactance of the generators and closed bus operation at all 400 and 220 kV buses.

It is observed that short circuit level for all the substations are within the rated breaking capacity of circuit breakers.

Detailed analysis of data and study results under winter off peak condition for load flow and short circuit studies are elaborated in subsequent sections of the report.

The reactive power compensation planning to be done by carrying out detailed analysis of the off peak load conditions by simulating various load generation scenarios and contingency cases.

ABBREVIATIONS AND ACRONYMS

Acronym	Full form
CEA	Central Electricity Authority
CGP/ CPP	Captive generating plant
CTU	Central Transmission Utility
DB	Data Base
DPR	Detailed Project Report
DTR	Distribution Transformer
EHV	Extra High Voltage
NER	North Eastern Region
NERLDC	North Eastern Regional Load Dispatch Centre
NERPC	North Eastern Regional Power Committee
Goi	Government of India
GS	Generating Station
GUI	Graphical User interface
HV	High Voltage
IPP	Independent Power Producer
MiP-PSCT	Protection Setting Calculation Tool
ER	Eastern Region
PRDC	Power Research & Development Consultants Pvt. Ltd.
PSS	Power System Study
SCADA	Supervisory control and data acquisition
SLD	Single Line Diagram
SLDC	State Load Dispatch Centre
SS	Substation
STU	State Transmission Utility

1 INTRODUCTION

North Eastern Regional Grid comprises of the electrical transmission system of the states of Assam, Meghalaya, Arunachal Pradesh, Tripura, Manipur, Mizoram, and Nagaland. The major constituents of NER grid are the Transmission and Distribution Utilities of States and Central Transmission Utility, State, Central and Private sector Generating Companies. The NER covers a geographical area of 2,62,230 sq. km with an installed capacity of 3539.38 MW. In addition to this the region has an installed capacity of 104.95 MW in the form of CPP's. Keeping in view the criticality of safe and reliable operation of this vast and complex system of NER, M/s. NERPC has awarded the project for implementation of a software based protection management system that includes building up a comprehensive web based protection database for the NER grid to M/s PRDC, a pioneer consultant in the field of power engineering on 12th October 2018.

As a fundamental prerequisite of building the protection management system and as base work for protection system simulation and studies the entire existing network data under NER system is modeled from 400 kV level to 66 kV buses. The network model in its entirety encompasses each of the individual power system elements including generators (hydro, thermal, gas), substations/switching station equipment, transmission lines, HVDC system, reactors, capacitors and load.

This report presents the results of the base case load flow studies for the modeled EHV transmission network of the NER grid for a selected scenario of winter off peak load condition. With reference to the discussions with M/s NERPC and its constituents, 19th December 2018 is identified as a typical day with a load at 19:00 hours. The load flow analysis is carried out with the load generation scenario for the selected instant and the parameters are crosschecked with the SCADA results to authenticate the correctness of the modeling.

NER network is modeled for 19th December 2018 19:00 hours, wherein power handling is less and over voltage criteria is predominant (demand recorded 2388 MW) for the NER grid. This volume of the report presents the details of existing North Eastern region transmission network data, load generation balance along with operational load flow and short circuit study results under winter off peak scenario.

2 PROJECT SCOPE

The scope of work envisaged in tender document is elaborated in detailed here.

As per scope M/s PRDC should supply Protection Analysis Software Package with following requirements but not limited to the following modules for the supply of Software and Database building activities,

M/s PRDC should develop and maintain a hardware setup and software package capable of meeting the following objectives; but not limited to:

- Classified database of all bay equipment and the protection system details of all bays for 66 kV and above for North Eastern Regional power system.
- A user friendly interface for browsing and editing the contents of the database.
- Tool for simulating the performance/ behavior of the protection system under all possible normal and abnormal operating conditions of the power system, including effect of changing one or more parameter setting of the relays.
- Diagnostics for verifying proper coordination among various protective relays.
- Generation of useful reports.

The detailed scope of work is elaborated in Volume-1 of the DPR and submitted on 09.10.2018. A consolidated view on Network Modeling and database building activity for operational load flow involves “Procurement of Web Based Protection Database Management Software and Protection Setting Calculation Tool for North Eastern Region” is presented below.

2.1 Database Building Activities for Operational Studies

- One time power system network model building for the Load flow and Short circuit simulations of entire North Eastern region with Indian national grid transmission network model.
- Data collected from respective substations to be validated before populating the same in the database.
- Complete software modeling of NER transmission network for 66 kV and above and also the connectivity with other regions is done with relevant system parameters of transmission lines, generators, along with power transformers, reactors and capacitors for all existing substations.
- Base case load flow analysis has been carried out on the NER network and the results to be verified with engineers of NER constituents. Both MW and

MVAr flow are computed and Voltage Level at different buses is ascertained along with suggestive conditions to reduce or enhance bus voltage.

- Short circuit, studies to be simulated and the results to be demonstrated to the NER constituents for approval.

This report includes operational load flow and short circuit study of existing NER grid under winter off peak loading condition.

3 SYSTEM OPERATIONAL DATA

As increasing electricity demand, electrical transmission and distribution system is expanding at very fast pace. To meet future expected demand with reliable manner there is a need of great integration among electricity generation, transmission and distribution agencies.

With an objective to facilitate integrated operation of power system in North Eastern Region, Govt. of India had established North Eastern Regional Power Committee comprising the states of Arunachal Pradesh, Assam, Manipur, Meghalaya, Mizoram, Nagaland and Tripura. The major constituents of NER grid are the Transmission and Distribution Utilities of States and Central Transmission Utility, State, Central and Private sector Generating Companies. Figure 3.1 depicts constituents of North Eastern Regional grid.

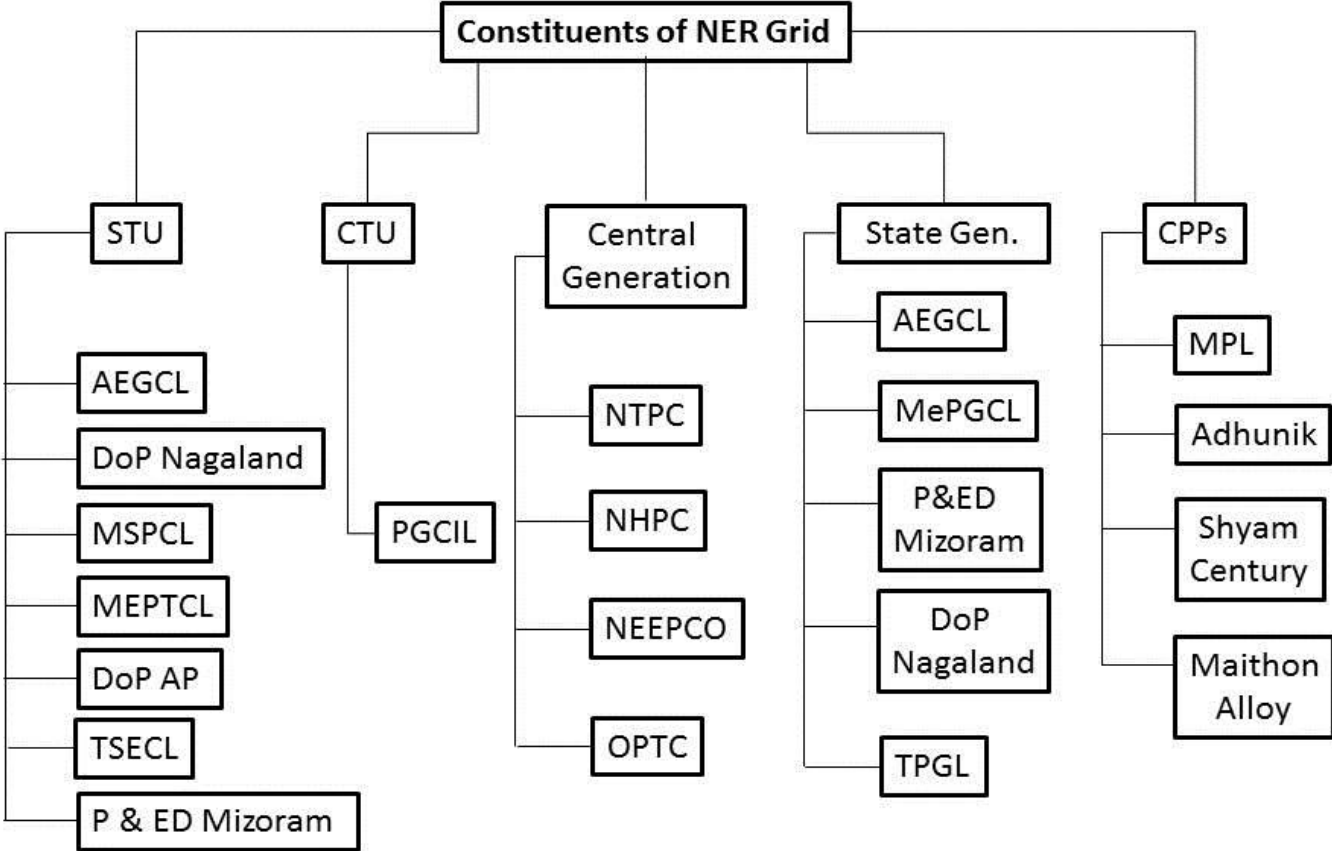

Figure 3.1: Constituents of North Eastern Regional grid

3.1 Methodology adopted for performing the load flow analysis

3.1.1 Data Collection Procedure

- In 151st OCC meeting, it was decided that operational load flow study under winter off peak loading scenario will be carried out for load conditions of 19.12.2018 at 19.00 hrs.
- To collect the North Eastern grid network data for operational load flow under off peak scenario a standard data collection format was prepared and forwarded to NERPC.
- Load generation data collection format was finalized by M/s PRDC and forwarded to NERPC.
- M/s PRDC has received the network data from most of the constituents in agreed format and remaining is collected from NERLDC.

Network data for all the utilities under North Eastern region were collected in co-ordination with NERPC and its constituents. The complete North Eastern Region Network from 400 kV level to 33 kV & 11 kV buses of 132/33 kV, 132/11 kV, 66/33 kV & 66/11 kV S/S is considered in the studies. Inter-regional and international transmission lines and HVDC line flow (modeled as lumped load) is also considered in the studies.

Network update data as collected from NER constituents and the state utilities has been also verified.

Table 3.1 present the collected/received data status from NERPC and its constituents.

Table 3.1: Data availability status

States under NERPC	State wise Data received*		
	Transformer Loading Received	Connectivity Flow Received	Generating Schedule Received
Assam	83.08%	29.50%	44.12%
Arunachal Pradesh	69.57%	15.00%	100.00%
Manipur	92.31%	100.00%	100.00%
Meghalaya	100.00%	93.33%	100.00%
Mizoram	77.27%	25.00%	0.00%
Nagaland	57.89%	80.65%	50.00%
Tripura	82.67%	86.00%	60.00%

Note: Network data includes CTU and STU network details as per state wise location.

**Percentage data calculation is based on data received from State utilities, central utilities and NERLDC (either MW or MW-MVAR flows considered).*

** SCADA snap shot of power flow is collected from NERLDC.*

Methodology adopted by the study team for performing the load flow analysis is as given below.

- Configuring the entire North Eastern Regional Grid electrical network down to 33 & 11 kV buses of the transmission substations. i.e. transmission system comprising of 400 kV, 220 kV, 132 kV and 66 kV substation buses up to the 33 & 11 kV buses at the substations.
- Represented the collective load of the substations at 33 & 11 kV buses.
- Slack bus is considered outside the region at the point having a maximum power exchange through AC links (Binaguri 400kV).
- ISGS generation scheduling is matched with NERLDC's SCADA record. Total generation of the state utilities is compared with the Daily Report published at NERLDC webpage.
- Allocation of load to the substations is finally done to match the state wise system demand as per NERLDC's SCADA record.
- In case of MVar data is unavailable, 0.95 power factor has been considered for calculation and to model the load at 33 and 11 kV bus.
- To match the system demand of NER, load data has been apportion based on data received from the utilities and Daily Power Supply Report published at NERLDC webpage.
- Simulation of load flow analysis under off peak scenario is done on the integrated Grid transmission network of North Eastern Region.
- Geographical drawings for entire North Eastern Regional Grid transmission network along with separate maps of North Eastern grid constituent states and SLD of entire NER grid till 132 kV has been modeled.
- North Eastern Regional transmission network is simulated under winter off peak scenario by taking load demand of 19.12.2018 at 19.00 hrs. Currently, the modeled North Eastern grid network has been simulated for the loading conditions which are given in Table 3.2.

Table 3.2: NER loading details

Date & Time	19 th December 2018, 19:00 hrs.
System Demand Met	3150 MW
Total Load	2388 MW
System Loss	98.55 MW
Loss	3.12%

➤ Software used : MiP-PSCT

3.2 December 19, 2018 Off-peak system demand condition

The study team has received substation wise load data and SCADA records from SLDC's of North Eastern Region and NERLDC. The data considered for modeling the transmission network and its sources are given in Table 3.3.

Table 3.3: Source of the data considered for the study

Sl. No.	Data	Source
1	Transformers	Data collected from NERLDC and SLDCs
2	Transmission lines / UG cable types	Data received from NERLDC, CTU, STU and other constituents
3	Lines / UG cable parameters	Data received from NERLDC, CTU, STU and other constituents and CEA planning criteria
4	Loads and Generation	SCADA recordings, Daily Report of NERLDC and Load data received from NERLDC, CTU and STUs

Note: Transmission lines and Transformers parameters, which are not furnished by CTU's and STU's, is considered as per CEA transmissions planning criteria.

This section of the report presents the basic data considered for the system studies.

3.3 Salient points of CEA planning criteria referred for system analysis

3.3.1 Transmission line parameters

Table 3.4 provides the transmission line parameters and the thermal loading limit of the transmission lines at various voltage levels considered for the studies.

Table 3.4: Details of transmission line parameters

Conductor Type	Voltage (kV)	Positive Sequence Resistance (ohm/km/ckt)	Positive Sequence Reactance (ohm/km/ckt)	Positive Sequence Suseptance, B/2 (mho/km/ckt)	Zero Sequence Resistance (ohm/km/ckt)	Zero Sequence Reactance (ohm/km/ckt)	Zero Sequence Suseptance, B/2 (mho/km/ckt)	Thermal Rating (MVA)
ACSR Quad Bersimis	765	0.0114	0.2856	2.01E-06	0.2634	1.0534	1.20E-06	3880
ACSR Hexa Zebra	765	0.0123	0.2552	2.27E-06	0.2247	0.9223	1.38E-06	4452
ACSR Quad Moose	400	0.0147	0.2528	2.29E-06	0.2480	1.0000	1.32E-06	1749
ACSR Twin Moose	400	0.0298	0.3320	1.73E-06	0.1619	1.2400	1.12E-06	874
AAAC Twin Moose	400	0.0309	0.3304	1.77E-06	0.1682	1.2368	1.14E-06	840
ACSR Zebra	220	0.0697	0.3978	1.46E-06	0.2048	1.3344	9.14E-07	213
ACSR MOOSE	220	0.0749	0.3993	1.47E-06	0.2200	1.3392	9.20E-07	240
AAAC Zebra	220	0.0749	0.3993	1.47E-06	0.2200	1.3392	9.20E-07	212
800sqmm XLPE Cable	220	0.0321	0.1260	3.23E-05	0.1400	0.0680	3.00E-05	266
ACSR Panther	132	0.1622	0.3861	1.46E-06	0.4056	1.6222	8.99E-07	83
LARK	132	0.1622	0.3861	1.46E-06	0.4056	1.6222	8.99E-07	94
T Snowbird	132	0.0223	0.2900	1.96E-06	0.2840	0.9784	1.36E-06	432
161 sqmm G.F Cable	132	0.1400	0.1873	4.25E-05	0.2700	0.0519	4.25E-05	50
260 sqmm G.F Cable	132	0.0876	0.2167	4.55E-05	0.1695	0.0600	4.55E-05	70
400 sqmm XLPE Cable	220	0.0617	0.1360	2.20E-05	0.2040	0.0830	2.19E-05	100
630 sqmm XLPE Cable	132	0.0391	0.1267	2.27E-05	0.1120	0.0840	2.24E-05	130
800 Sqmm XLPE Cable	132	0.0321	0.1260	3.23E-05	0.1300	0.0680	3.00E-05	160
ACSR DOG	66	0.3274	0.4267	1.36E-06	0.5578	1.3688	9.84E-07	50

Note: Transmission lines parameters, which are not furnished by CTU and STU's, is consider as per CEA transmissions planning criteria.

3.4 Transformer parameters

Actual transformer parameters wherever provided by CTU and STU's is used. In cases where data is not furnished standard data as per CEA transmissions planning criteria given in Table 3.5 is considered.

Table 3.5: Details of transformer parameters

Type of Transformer	Transformer reactance Xt (at its own base MVA)
Generator transformer (GT)	14 – 15 %
Inter-Connecting Transformer (ICT)	12.50%

3.4.1 Voltage limits

The steady-state voltage limits prescribed in CEA's "Transmission Planning Criteria" at different voltage levels are presented in Table 3.6.

Table 3.6: Voltage limits at different voltage levels prescribed in CEA's "Transmission Planning Criteria"

Nominal Voltage (kV)	Normal rating				Emergency rating			
	Maximum		Minimum		Maximum		Minimum	
	kV	pu	kV	pu	kV	pu	kV	pu
400	420	1.05	380	0.95	420	1.05	372	0.93
220	245	1.11	198	0.90	245	1.11	194	0.88
132	145	1.10	122	0.92	145	1.10	119	0.90
66	72.5	1.10	60	0.91	72.5	1.10	59	0.89

3.5 Network element statistics for NER Grid

3.5.1 Substation details

The summary of the number of substations present in the North Eastern region state wise is presented in Table 3.7 and the complete list of substations along with load considered at each substation is given in Table A of Annexure-I.

Table 3.7: Existing number of sub-station in the NER

Sl. No.	Substation*	State						
		Arunachal Pradesh	Assam	Manipur	Meghalaya	Mizoram	Nagaland	Tripura
1	400 kV	-	6	-	1	-	-	-
2	220 kV	1	11	-	-	-	2	-
3	132 kV	12	54	18	17	10	6	14

Sl. No.	Substation*	State						
		Arunachal Pradesh	Assam	Manipur	Meghalaya	Mizoram	Nagaland	Tripura
4	66 kV	-	-	-	-	-	11	11
Total No. of S/S in NER				174				

Note: If 400/220/132 kV substation has 220/132 kV transformation level also, in that case 400/220/132 kV substation is counted as single 400 kV substation.

*Above listed substation number excludes generating stations.

3.5.2 Transmission line details

The summary of Transmission line data present in the North Eastern Region is presented in Table 3.8 and the complete list of transmission lines state wise is given in Table B of Annexure-I.

Table 3.8: Summary of transmission line data in the NER

Sl. No.	Voltage (kV)	Line Length (ckm)
1	800	3452
2	400	5463.4
3	220	2736.71
4	132	8974.07
5	66	1135.26

3.5.3 Transformer details

The summary of Transformer data present in the North Eastern Region is presented below in Table 3.9 and the complete list of substation and their transformation capacity for each constituent state of NER Grid is given in Table A of Annexure-I.

Table 3.9: Summary of transformers capacity in the NER

Sl. No	Voltage Ratio (kV)	Installed Capacity (MVA)
1	400	3835
2	220	3210
3	132	5947.4
4	66	575.5

3.5.4 Generation details

The summary of generator installed capacity present in the North Eastern Region state wise is presented in Table 3.10 and the complete list of generators is given in Table C of Annexure-I.

Table 3.10: Summary of Generator installed capacity in the NER

Sl. No.	State	Installed capacity (MW)*		
		Hydro	Thermal	Gas
1	Arunachal Pradesh	515	-	-
2	Assam	375	597.2	414.5
3	Manipur	105	-	-
4	Meghalaya	269.2	104.95 (CPPs)	-
5	Mizoram	82.8	-	-
6	Nagaland	99	-	-
7	Tripura	15	374.82	691.86
Total NER		1461	1076.97	1106.36
		3644.33		

*Note: Installed capacity includes central, state and CPP generations

3.5.5 HVDC details

The details of the existing converter stations used for HVDC transmission and HVDC Back to Back, considered in the studies are given in Table 3.11 and Table 3.12.

Table 3.11: HVDC BI Pole in the NER

Sl. No.	Parameter	Biswanath Chariyali BI Pole
1	Power Rating	2 X 1500 MW
2	Number of 6 pulse Bridges	2
3	AC voltage	400 kV
4	DC voltage	± 800 kV
5	Converter (Rectifier) transformer	12 X 295.5 MVA

Table 3.12: HVDC Link in the NER

Sl. No.	Parameter	Biswanath Chariyali to Agra
1	Power Rating	3000 MW
2	Number of Poles	2
3	Conductor Type	Hexa Lapwing
4	Line length in km	1752

3.5.6 Reactor details

Substation wise total reactive power compensation considered in study is summarized in Table 3.13. The complete list of state wise reactors installed in the North Eastern region is presented in Table D and E of Annexure-I respectively.

Table 3.13: Substation wise total reactive power compensation details

Name of the substaion	Bus Reactor Total capacity (MVA)	Line Reactor Total capacity (MVA)	Total Reactor capacity (MVA)	Total Cap Bank capacity (MVA) ** HVDC Filter
400 kV				
Biswanath Chariyali	286	-	286	250
Azara	63	63	126	-
Balipara (PG)	230	163	393	-
Bongaigaon (PG)	435	415	850	-
Silchar (PG)	0	226	226	-
Misa (PG)	150	50	200	-
Byrnihat (Killing)	63	50	113	-
Palatana	80	-	80	-
Ranganadi	80	100	180	-
220 kV				
Mariani (AEGCL)	0	-	0	-
Samaguri	12.5	-	12.5	-
Kathalguri (GEN) (AGBPP)	-	20	20	-
132 kV				
Ziro	0	-	0	-
Roing	20	-	20	-
Tezu	20	-	20	-
Imphal(PG)	20	-	20	-
Aizawl	20	-	20	-
DHARMANAGAR	4	-	4	-
KUMARGHAT (PG)	20	-	20	-

3.5.7 Load details

The state wise summary of load data considered for the study is given in Table 3.14. Substation wise loading details considered for operational load flow is presented in Table F of Annexure-I.

Table 3.14: Load Details of NER

Sl. No.	States	Load*
1	Arunachal Pradesh	105
2	Assam	1363
3	Manipur	169
4	Meghalaya	327
5	Mizoram	86
6	Nagaland	125
7	Tripura	213

*Note: 2388 MW (summation of recorded loads in S/S) on 19.12.2018 at 19:00 hrs in NER grid

3.6 Generation schedule details for operational load flow

The generation schedule considered was based on the information obtained from the NERLDC and other constituents of NER grid. Power plant wise generation allocation is given in Table 3.15 and graphically represented in figure 3.2.

Table 3.15: Generation schedule Details of NER

Sl.No.	State	Station Name	Owned By	Scheduled Generation (MW)
1	Arunachal Pradesh	Ranganadi	NEEPCO	380.01
2		Pare	NEEPCO	54
1	Assam	Bongaigaon (NTPC) (BgTPP)	NTPC	426
2		Kathalguri (AGBPP) 400/220	NEEPCO	218
3		Kopili	NEEPCO	158
4		Lower Kopili	NEEPCO	0
5		Khandong	NEEPCO	40
6		Namrup (NTPS) 220/132/66/33	APGCL & AEGCL	55.22
7		Karbi Longpi	APGCL	100
8		LTPS (Lakwa), LRPP	APGCL & AEGCL	126.78
1	Manipur	Loktak	NHPC	105
1	Meghalaya	Umiam Stage I(Sumer)	MePGCL	13.4
2		Umiam Stage II (Umsumer)	MePGCL	6.69
3		Umiam Stage III(Kydremkulai)	MePGCL	24.697
4		Umiam Stage IV(Nongkhyllem)	MePGCL	24.697
5		MLHEP (Myntdu Leshka)	MePGCL	36.02
6		Umtru	MePGCL	0
7		New Umtru	MePGCL	18.523
1	Mizoram	Turial	NEEPCO	7
2		Bairabi	P&E D Mizoram	20
1	Nagaland	Doyang Hydroelectric project	NEEPCO	39
2		Likimro Hydroelectric project	Dop, Nagaland	15.99
1	Tripura	AGTPP	NEEPCO	82
2		Monarchak	NEEPCO	87.9
3		Palatana	OTPC(ONGC)	569
4		Rokhia	TPGL	56.01

Sl.No.	State	Station Name	Owned By	Scheduled Generation (MW)
5		Gumti	TPGL	0
6		Baramura	TPGL	21

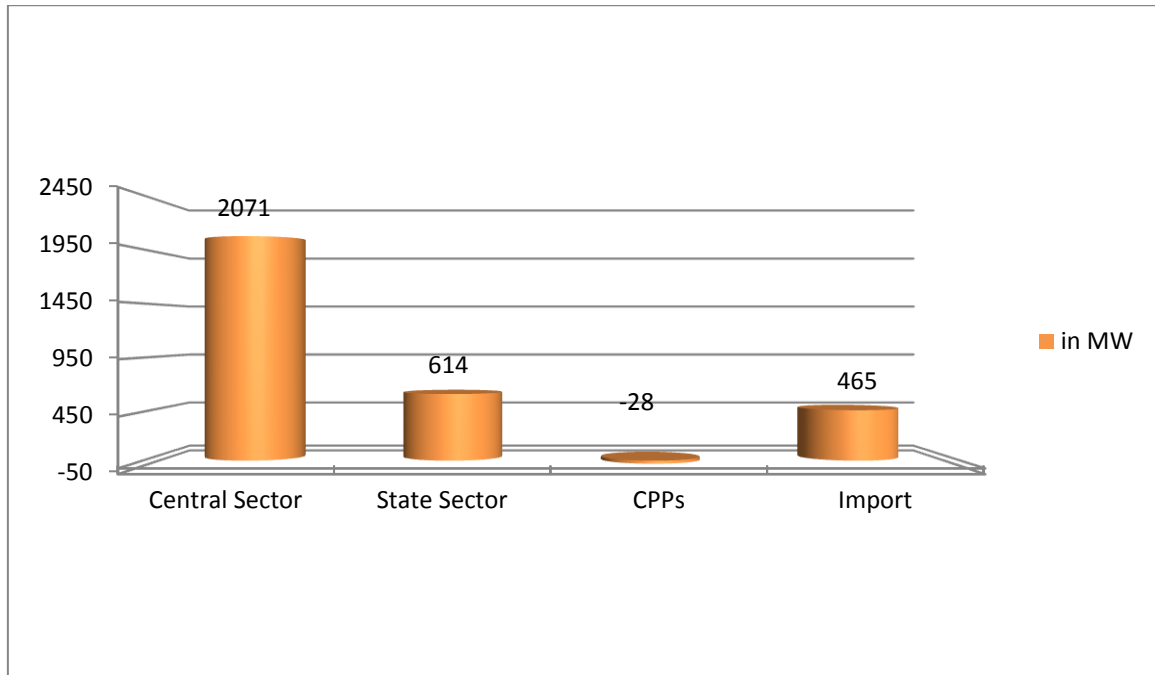

Figure 3.2: Scheduled generation and Import of North Eastern Regional grid

4 OPERATIONAL LOAD FLOW STUDY

4.1 Introduction to Load flow analysis

One of the most common computational procedures used in power system analysis is the load flow calculation. The planning, design and operation of power systems require such calculations to analyze the steady state performance of power system under various operating conditions and to study the effects of changes in network configuration. These load flow solutions are performed using computer programs designed specifically for this purpose.

The basic question in the load flow analysis is: “Given the demand at all buses of a known electric power system configuration and the power production at each generator, find the power flow in each line and transformer of the interconnecting network and the voltage magnitude with phase angle at each bus.”

Analyzing the solution of load flow analysis for numerous conditions helps ensure that the power system is designed to satisfy its performance criteria while incurring the most favorable investment and operation costs. Some examples of the uses of load flow studies are to determine,

- Component or circuit loading.
- Steady state bus voltages.
- Active and Reactive power flows.
- Transformers tap settings.
- System losses.
- Performance under emergency conditions.

Modern systems are complex and have many paths or branches over which power can flow. Such systems form networks of series and parallel paths. Electric power flow in these networks divides among the branches until a balance is reached in accordance with established circuit theory.

Computer programs to solve load flows are divided into two type's static (offline) and dynamic (real time). Most load flow studies for system analysis are based on static network models. Real time load flows (online) that incorporate data input from the actual networks are typically used by utilities in Supervisory Control and Data Acquisition (SCADA) systems. Such systems are used primarily as operating tools for optimization of generation, VAR control, dispatch, losses, and tie line flow control. This discussion is concerned with only static network models and their analysis.

A load flow calculation determines the state of the power system with respect to a given load and generation schedule. It represents a steady state condition which is assumed to remain fixed for some time. In reality, line flows and bus voltages fluctuate in small amounts because load changes due to lights, motors, and other loads being turned on or off in the system. However, these small fluctuations are ignored in calculating the steady state effects on system equipment. As the load distribution, and hence power flow in the network vary considerably during different time periods, it may be necessary to obtain load flow solutions representing different system conditions such as peak load, average load or light load. Generally, these solutions provide,

- Optimum operating modes for normal conditions, such as proper setting of voltage control devices, or how the system will respond to abnormal conditions, such as outage of transformers or lines.

- When the new equipment additions are needed.
- Effectiveness of new alternatives to solve present deficiencies and meet future requirements.

The load flow model is also the basis for several other types of studies such as short circuit, stability, motor starting, and harmonic studies. The load flow model supplies the network data and an initial steady state condition for these studies.

The present study is carried out to determine the power flows at different lines/transformers and to compute the voltage profile at different buses of the existing system. The system configuration considered for the study and simulation results are explained in the subsequent sections.

4.2 Load Generation Balance from the results of operational load flow analysis

The detail of load generation balance of NER is given in Table 4.1 and state wise load generation balance is presented in Table 4.2, 4.3, 4.4, 4.5, 4.6, 4.7 and 4.8. The detailed load and generation data is given in Annexure-I.

Table 4.1: Load generation balance Details of NER

Sl. No.	Description	Quantity (MW)
1	Generation	2684.94
2	Import	465.00
3	Total generation	3149.94
4	Loss	98.55
5	Percentage Loss	3.12
6	Export	663.40
7	Load	2387.99
8	Total Load	3051.39
Total Demand		3149.94

**Note: Only for 400 kV, 220 kV, 132 kV and 66 kV transmission network.*

Table 4.2: Load generation balance details of Arunachal Pradesh

Sl. No.	Description	Quantity (MW)
1	Generation	434.01
2	Import	17.43
Total (Generation + Import)		451.44
4	Loss	6.28
5	Export	340.16

Sl. No.	Description	Quantity (MW)
6	Load	105.00
Total (Load + Export + Loss)		451.44

*Note: Only for 400 kV, 220 kV, 132 kV and 66 kV transmission network

Table 4.3: Load generation balance details of Assam

Sl. No.	Description	Quantity (MW)
1	Generation	1124.00
2	Import	1294.36
Total (Generation + Import)		2418.36
4	Loss	54.02
5	Export	1001.34
6	Load	1363.00
Total (Load + Export + Loss)		2418.36

*Note: Only for 400 kV, 220 kV, 132 kV and 66 kV transmission network

Table 4.4: Load generation balance details of Manipur

Sl. No.	Description	Quantity (MW)
1	Generation	105.00
2	Import	86.96
Total (Generation + Import)		191.96
4	Loss	5.98
5	Export	16.98
6	Load	169.00
Total (Load + Export + Loss)		191.96

*Note: Only for 132 kV transmission network

Table 4.5: Load generation balance details of Meghalaya

Sl. No.	Description	Quantity (MW)
1	Generation	124.03
2	Import	255.22
Total (Generation + Import)		379.25
4	Loss	9.75
5	Export	42.20
6	Load	327.30
Total (Load + Export + Loss)		379.25

*Note: Only for 400 kV and 132 kV transmission network

Table 4.6: Load generation balance details of Mizoram

Sl. No.	Description	Quantity (MW)
1	Generation	27.00
2	Import	61.54

Sl. No.	Description	Quantity (MW)
Total (Generation + Import)		88.54
4	Loss	2.54
5	Export	0.00
6	Load	86.00
Total (Load + Export + Loss)		88.54

**Note: Only 132 kV transmission network*

Table 4.7: Load generation balance details of Nagaland

Sl. No.	Description	Quantity (MW)
1	Generation	54.99
2	Import	81.40
Total (Generation + Import)		136.39
4	Loss	3.62
5	Export	7.77
6	Load	125.00
Total (Load + Export + Loss)		136.39

**Note: Only for 220 kV, 132 kV and 66 kV transmission network*

Table 4.8: Load generation balance details of Tripura

Sl. No.	Description	Quantity (MW)
1	Generation	815.91
2	Import	0.00
Total (Generation + Import)		815.91
4	Loss	16.35
5	Export	586.87
6	Load	212.69
Total (Load + Export + Loss)		815.91

**Note: Only for 132 kV and 66 kV transmission network*

A block diagram illustrating the interstate and inter regional power exchange of NER is presented in figure 4.1

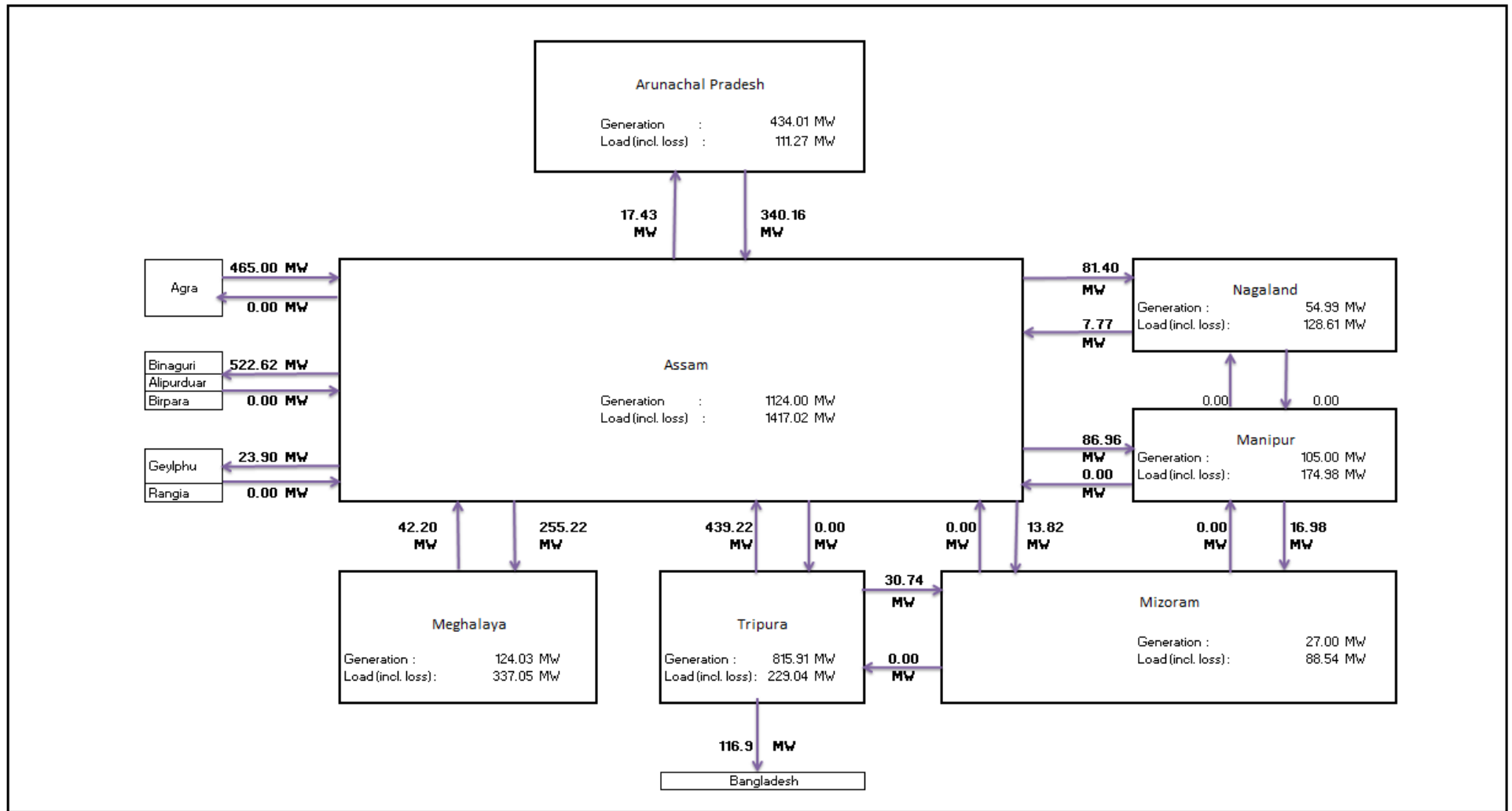

Figure 4.1: Block diagram of load generation balance of NER

Note: Inter regional exchange is shown as net exchange

4.3 Line loading conditions

Under operational load flow study, number of lines whose loading is below 5% and above 80% is presented in Table 4.09 for entire NER grid and Table 4.10 to 4.16 for constituent state of NER grid.

Table 4.09: Percentage loading details of lines of North Eastern Region

Sl no.	Voltage (kV)	Max	Min	Avg.	No. of lines over 100%	No. of lines over 80%	No. of lines under 5%
1	400	22.9	6.6	12.98	0	0	0
2	220	53.8	1.7	16.72	0	0	5
3	132	91.3	0.2	22.18	0	5	36
4	66	70.5	6.2	26.77	0	0	0

Table 4.10: Percentage loading details of lines of Arunachal Pradesh

Sl no.	Voltage (kV)	Max	Min	Avg.	No. of lines over 100%	No. of lines over 80%	No. of lines under 5%
1	400	18.2	18.2	18.2	0	0	0
2	220	1.7	1.7	1.7	0	0	1
3	132	40.3	2.8	17.67	0	0	4
4	66	-	-	-	-	-	-

Table 4.11: Percentage loading details of lines of Assam

Sl no.	Voltage (kV)	Max	Min	Avg.	No. of lines over 100%	No. of lines over 80%	No. of lines under 5%
1	400	22.9	6.6	12.64	0	0	0
2	220	53.8	1.9	17.07	0	0	4
3	132	90.4	0.2	28.92	0	3	8
4	66	16.5	12.4	13.52	0	0	0

Table 4.12: Percentage loading details of lines of Manipur

Sl no.	Voltage (kV)	Max	Min	Avg.	No. of lines over 100%	No. of lines over 80%	No. of lines under 5%
1	400	-	-	-	-	-	-
2	220	-	-	-	-	-	-
3	132	83.2	2.4	22.75	0	1	5

SI no.	Voltage (kV)	Max	Min	Avg.	No. of lines over 100%	No. of lines over 80%	No. of lines under 5%
4	66	-	-	-	-	-	-

Table 4.13: Percentage loading details of lines of Meghalaya

SI no.	Voltage (kV)	Max	Min	Avg.	No. of lines over 100%	No. of lines over 80%	No. of lines under 5%
1	400	9.7	9.7	9.7	0	0	0
2	220	-	-	-	-	-	-
3	132	58.9	0.5	16.73	0	0	13
4	66	-	-	-	-	-	-

Table 4.14: Percentage loading details of lines of Mizoram

SI no.	Voltage (kV)	Max	Min	Avg.	No. of lines over 100%	No. of lines over 80%	No. of lines under 5%
1	400	-	-	-	-	-	-
2	220	-	-	-	-	-	-
3	132	68.9	3	22.81	0	0	2
4	66	-	-	-	-	-	-

Table 4.15: Percentage loading details of lines of Nagaland

SI no.	Voltage (kV)	Max	Min	Avg.	No. of lines over 100%	No. of lines over 80%	No. of lines under 5%
1	400	-	-	-	-	-	-
2	220	-	-	-	-	-	-
3	132	31.2	4.3	15.86	0	0	1
4	66	64.2	9.1	28.61	0	0	0

Table 4.16: Percentage loading details of lines of Tripura

SI no.	Voltage (kV)	Max	Min	Avg.	No. of lines over 100%	No. of lines over 80%	No. of lines under 5%
1	400	-	-	-	-	-	-
2	220	-	-	-	-	-	-
3	132	91.3	3.7	21.03	0	1	3
4	66	70.5	6.2	28.46	0	0	0

Note: As observed in operational load flow that no line is loaded 100% and above.

4.4 Transformer loading conditions

Under operational load flow study, number of transformers whose loading is below 20% and above 80% is presented in Table 4.17 for entire NER grid and Table 4.18 to 4.25 for constituent state of NER grid.

Table 4.17: Percentage loading details of Transformers of North Eastern Region

SI no.	Voltage (kV)	Percentage Loading					
		Max	Min	Avg.	No. of transformers over 100%	No. of transformers over 80%	No. of transformers under 20%
1	400	81	7.2	39.14	0	1	2
2	220	86.8	3.6	39.11	0	1	7
3	132	125.2	1.5	43.86	4	31	56
4	66	97.2	0.7	41.18	0	3	14

Table 4.18: Percentage loading details of Transformers of Arunachal Pradesh

SI no.	Voltage (kV)	Percentage Loading					
		Max	Min	Avg.	No. of transformers over 100%	No. of transformers over 80%	No. of transformers under 20%
1	400	48.5	48.5	48.5	0	0	0
2	220	3.6	3.6	3.6	0	0	1
3	132	80.3	1.5	40.38	0	1	8
4	66	-	-	-	-	-	-

Table 4.19: Percentage loading details of Transformers of Assam

SI no.	Voltage (kV)	Percentage Loading					
		Max	Min	Avg.	No. of transformers over 100%	No. of transformers over 80%	No. of transformers under 20%
1	400	72.5	21.8	35.89	0	0	0
2	220	86.8	5.2	39.87	0	1	6
3	132	102.3	3	45.54	3	11	18
4	66	65.1	9	23.58	0	0	10

Table 4.20: Percentage loading details of Transformers of Manipur

SI no.	Voltage (kV)	Percentage Loading					
		Max	Min	Avg.	No. of transformers over 100%	No. of transformers over 80%	No. of transformers under 20%
1	400	-	-	-	-	-	-
2	220	-	-	-	-	-	-
3	132	91.3	9	26.68	0	1	18
4	66	-	-	-	-	-	-

Table 4.21: Percentage loading details of Transformers of Meghalaya

SI no.	Voltage (kV)	Percentage Loading					
		Max	Min	Avg.	No. of transformers over 100%	No. of transformers over 80%	No. of transformers under 20%
1	400	7.2	7.2	7.2	0	0	2
2	220	24.2	24.2	24.2	0	0	0
3	132	125.2	20.5	56.68	1	7	0
4	66	-	-	-	-	-	-

Table 4.22: Percentage loading details of Transformers of Mizoram

SI no.	Voltage (kV)	Percentage Loading					
		Max	Min	Avg	No. of transformers over 100%	No. of transformers over 80%	No. of transformers under 20%
1	400	-	-	-	-	-	-
2	220	-	-	-	-	-	-
3	132	84.1	2.1	46.81	0	6	6
4	66	-	-	-	-	-	-

Table 4.23: Percentage loading details of Transformers of Nagaland

SI no.	Voltage (kV)	Percentage Loading					
		Max	Min	Avg.	No. of transformers over 100%	No. of transformers over 80%	No. of transformers under 20%
1	400	-	-	-	-	-	-
2	220	54.6	26.6	40.6	0	0	0
3	132	94.9	10.1	50.09	0	3	1
4	66	97.2	0.7	50.41	0	3	3

Table 4.24: Percentage loading details of Transformers of Tripura

SI no.	Voltage (kV)	Percentage Loading					
		Max	Min	Avg.	No. of transformers over 100%	No. of transformers over 80%	No. of transformers under 20%
1	400	81	51.6	62.62	0	1	0
2	220	-	-	-	-	-	-
3	132	96.4	5.9	42.17	0	2	5
4	66	74.9	11.4	45.98	0	0	1

4.5 Voltage profile

Bus Voltage Profile for North Eastern Regional grid is presented in Table 4.25

Table 4.25: Bus Voltage Profile for North Eastern Region

SI.No	Voltage Grade (kV)	Bus Voltage in pu				Average Voltage in pu
		Bus name	Max	Bus name	Min	
2	400	Palatana	1.029	Bongaigaon	1.008	1.017
3	220	Mariani PG	1.05	Sonapur	1.004	1.021
4	132	Deomali	1.044	Dhemaji	0.863	0.991
5	66	Tinsukia	1.01	Gakulnagar	0.884	0.957

Note: As observed in operational load flow study that bus voltage of NER grid is within the acceptable limit (as per CEA grid code).

Comparison of SCADA record with simulated result for 400 kV and 220 kV Bus Voltage of North Eastern Region grid is presented in Table 4.26

Table 4.26: 400 kV and 220 kV Bus Voltage of North Eastern Region grid

Sl.No	Name of the SubStation	Bus Number	Voltage level (kV)		Voltage in pu		Difference	% Difference
			Nominal	Data Received	Recorded	Simulated		
Assam								
1	Biswanath Chariyali HVDC		800		-	-	-	-
		5294007	400	406	1.015	1.021	0.006	0.58%
2	Azara (Kukurmara)	5214001	400	406	1.015	1.012	-0.003	-0.33%
		5212001	220		-	1.012	-	-
3	Sonapur	5212002	220		-	1.004	-	-
4	Balipara PG	5294001	400	407	1.018	1.02	0.003	0.29%
		5292001	220	223.2	1.015	1.014	-0.001	-0.08%
5	Silchar PG	5294003	400	408.6	1.022	1.022	0.001	0.06%
6	Misa PG	5294004	400	408.7	1.022	1.021	-0.001	-0.11%
		5292004	220	219	0.995	1.013	0.017	1.71%
7	Bongaigaon PG	5294002	400	399	0.998	1.008	0.01	1.03%
		5292002	220	221.5	1.007	1.011	0.004	0.38%
		5291002	132	134.6	1.02	1.031	0.011	1.11%
8	Mariani (PG)	5212031	220	229.4	1.043	1.03	-0.013	-1.22%
9	Bongaigaon (BTPS) (ASEB)	5272001	220		-	1.01	-	-
10	Tinsukia	5212030	220		-	1.041	-	-
11	Mariani	5212031	220	229	1.041	1.03	-0.011	-1.05%
12	Samaguri	5212032	220		-	1.008	-	-
		5211032	132	130	0.985	1.001	0.016	1.63%
13	Sarusajai	5212033	220		-	1.01	-	-
14	Boko	5212034	220		-	1.009	-	-
15	Agia	5212035	220		-	1.007	-	-
16	Sonabil	5212036	220		-	1.012	-	-
17	Jawaharnagar	5212042	220		-	1.01	-	-
18	Kathalguri/AgBPP	5292005	220	233	1.059	1.046	-0.013	-1.27%
19	Khandong	5241001	132	133	1.008	1.015	0.008	0.75%
20	Kopili	5221003	132	137	1.038	1.014	-0.023	-2.26%
21	Kahlipara	5211126	132	135	1.023	1	-0.023	-2.25%
22	Badarpur	5211103	132	133.5	1.011	1.001	-0.01	-0.99%
23	Pailapool	5211101	132	133.91	1.014	1.004	-0.01	-1.00%
24	Jorhat	5211115	132	134	1.015	1.007	-0.008	-0.78%
25	Halfong PG	5291106	132	134.3	1.017	1.012	-0.005	-0.50%
Tripura								
1	Palatana	5734001	400	413			-0.004	-0.39%
2	P K Bari	5701002	132				-	-
3	SURAJMANI NAGAR	5701001	132	133			-0.02	-2.01%

Procurement of Web Based Protection Database Management Software and Protection Setting Calculation Tool for North Eastern Region

Sl.No	Name of the SubStation	Bus Number	Voltage level (kV)		Voltage in pu		Difference	% Difference
			Nominal	Data Received	Recorded	Simulated		
4	DHARMANAGAR (MISSION TILLA)	5701003	132				-	-
5	KAILASAHAR(Gournagar)	5701004	132				-	-
6	KUMARGHAT(PGCIL)	5791004	132	131			-0.002	-0.18%
7	KAMALPUR	5211141	132				-	-
8	DHALABIL(KHOWAI)	5701006	132				-	-
9	AMBASSA	5701007	132				-	-
10	UDAIPUR (BANDUAR)	5701008	132				-	-
11	RAMCHANDRANAGAR (GBPS)	5741008	132				-	-
12	AGARTALA (79 TILLA)	5701009	132	133			-0.016	
13	BODHJANGNAGAR	5701011	132				0.988	
14	JIRANI	5701012	132				0.983	
15	BARAMURA	5701013	132				0.981	
16	ROKHIA	5701014	132				0.997	
17	TELIAMURA (GAMAITILLA)	5701018	132				0.981	
18	RABINDRANAGAR(Sonamura)	5701022	132				0.997	
19	MONARCHAK	5741022	132				0.998	
Meghalaya								
1	Byrnihat (Killing)	5404001	400				-	-
		5402001	220				-	-
		5401001	132				1.003	
2	Mendipather	5401005	132				-	-
3	Rongkhon (Tura	5401007	132				-	-
4	Nangalbibra	5401008	132				-	-
5	Nongstoin	5401009	132				-	-
6	Mawngap (Mawphlang)	5401010	132				-	-
7	Sohra (Cherrapunjee)	5401011	132				-	-
8	Mawlai	5401012	132				-	-
9	Umiam	5401013	132				-	-
10	Umiam Stg I	5401014	132				0.993	
11	Umiam Stg II	5401015	132				0.994	
12	Umiam Stg III	5401016	132				-	-
13	Umiam Stg IV	5401017	132				1	
14	Umtru	5401018	132				1.001	
15	EPIP II (Norbong)	5401019	132				-	-
16	EPIP I (Norbong/Rajabagan)	5401020	132				-	-
17	Nehu	5401021	132	128			0.022	2.28%

Procurement of Web Based Protection Database Management Software and Protection Setting Calculation Tool for North Eastern Region

Sl.No	Name of the SubStation	Bus Number	Voltage level (kV)		Voltage in pu		Difference	% Difference
			Nominal	Data Received	Recorded	Simulated		
18	NEIGRIHMS	5401022	132				-	-
19	Mustem (Jowai)	5401023	132				-	-
20	Khliehriat(S)	5401024	132				-	-
21	Lumshnong	5401025	132				-	-
22	Myntdu Leshka	5401026	132				-	-
23	New Umtru	5401027	132				-	-
24	Khliehriat_PG	5491028	132	131.7			0.007	0.71%
Manipur								
1	Imphal(PG)	5391001	132				-	-
2	Jiribam (PG)	5391002	132	133			-0.003	-0.26%
3	Imphal(Yurembam)	5301001	132	132			-0.004	-0.45%
4	Karong(Senapati)	5301002	132				-	-
5	Jiribam (state)	5301003	132				-	-
6	Churachandpur	5301004	132				-	-
7	Kakching	5301005	132				-	-
8	Ningthoukhong	5301006	132				-	-
9	Yaingangpokpi	5301007	132				-	-
10	Rengpang	5301009	132				-	-
11	Kongba	5301010	132				-	-
12	Hundung	5301011	132				-	-
13	Chandel	5301012	132				-	-
14	Elangkhangpokpi	5301013	132				-	-
15	Tipaimukh	5301014	132				-	-
16	Loktak	5361008	132	132			0.024	2.38%
17	Thoubal	5301015	132				-	-
18	Moreh	5301016	132				-	-
19	Thalon	5301017	132				-	-
Mizoram								
1	Aizal PGCIL	5591001	132	123.5			0.011	1.16%
2	Melriat PG	5591010	132				-	-
3	Bairabi	5501001	132				-	-
4	Khawzawl	5501002	132				-	-
5	Kolasib (Bawklang)	5501003	132				-	-
6	Luangmual	5501004	132				-	-
7	Saitual	5501005	132				-	-
8	Zungtui(Zemabawk)	5501006	132				-	-
9	Bukpui (Serchip)	5501007	132				-	-

Procurement of Web Based Protection Database Management Software and Protection Setting Calculation Tool for North Eastern Region

Sl.No	Name of the SubStation	Bus Number	Voltage level (kV)		Voltage in pu		Difference	% Difference
			Nominal	Data Received	Recorded	Simulated		
10	Khawiva(Lunglei)	5501008	132				-	-
11	Keifangtlang(Champai)	5501009	132				-	-
12	Turial	5541010	132				0.986	
Nagaland								
1	Nagarjan Dimapur(PG)	5692001	220	220			0.009	0.86%
		5691001	132	132			-0.002	-0.19%
2	Mokokchung_PG	5692002	220	228			0.011	1.05%
		5691002	132				-	-
3	Dimapur Power house(DoP Nag)	5601001	132				-	-
4	Mokokchung/ Aolichen MKG	5601002	132				-	-
5	SANIS	5601003	132				-	-
6	WOKHA	5601004	132				-	-
7	Kiphire	5601005	132				-	-
8	Kohima	5601006	132				-	-
9	Meluri	5601007	132				-	-
Arunachal								
1	Ranganadi	5144001	400				-0.002	-0.22%
		5141001	132				-	-
2	Pare	5141012	132				-	-
3	Nirjuli	5191001	132				0.001	0.09%
4	Naharlagun(Lekhi)	5101002	132				0.01	0.99%
5	Itanagar	5101003	132				0.003	0.30%
6	Khuppi	5101004	132				-	-
7	Ziro	5191005	132				-	-
8	Daporijo	5101005	132				-0.011	-1.11%
9	Along	5101006	132				-0.009	-0.91%
10	Deomali	5102007	220				-	-
		5101007	132				-	-
11	Bhalukpong	5101008	132				-0.004	-0.43%
12	Tezu	5191009	132				-	-
13	Passighat	5101009	132				-0.017	-1.64%
14	Roing	5191010	132				-	-
15	Namsai	5101011	132				-	-

From analysis of voltage profile of NER grid it is observed that bus bar voltages of all the substations are within limits, as per CEA grid code stipulations. Comparison chart of simulated voltage and recorded voltage is given above. Maximum deviation of voltage is

2.38% at Loktak S/s. Deviation of recorded and simulated voltages above 2% (5 no. of Buses) are highlighted.

4.6 Synopsis of Load Flow Study Results

- Power map of NER grid along with separate power map of constituent states (Arunachal Pradesh, Assam, Manipur, Meghalaya, Mizoram, Nagaland and Tripura) and NER SLD for operational load flow study is presented in Annexure-II.
- Line loading details are presented in Table G of Annexure-II.
- From the off peak load flow analysis results it is observed that the 400 & 220 kV bus voltages of the NER grid are on the higher side of the stipulated grid code. Due to under loading of transmission lines, maximum voltage observed at 400 kV and 220kV are 1.029(Palatana) and 1.05(Mariani PG) respectively.
- No overloading is observed in any of the voltage grades. Number of lines loaded between 80 to 100% of their thermal capacity is 5 predominantly in 132 kV level. Numbers of lines loaded below 5% of thermal capacities are 5 at 220 kV level I and 41 at 132 kV level.
- In the entire region, overloading of 4 transformers is observed. 36 no. of transformer loaded beyond 80% and 79 numbers are loaded below 20% of rated capacity which is predominantly in 132kV voltage level.
- Maximum inter regional power exchange is 522.6MW to Eastern region.

5 SHORT CIRCUIT STUDIES

Even the most carefully designed power systems may be subjected to damaging arc blast or overheating and the explosive magnetic forces associated with high magnitude currents flowing during a short circuit. To ensure that circuit's protective equipment can isolate faults quickly and minimize system component damage, personal hazard and outage severity, it is essential that a short circuit study be included in the electrical design of new industrial and commercial power systems, and for modifications to existing system. There are five possibilities for a short circuit in three-phase system.

- 3-phase to ground fault.
- Single line to ground fault.
- Line to line fault.
- Double line to ground fault.
- Open conductor fault.

If a short circuit of one type is not interrupted promptly, it often progresses to another type, which generally results in more severe damage. For example in a solidly grounded system, a single line to ground fault, if not interrupted, can quickly escalate to a double line to ground or a three phase to ground fault. The choice of study that is required for a particular system is a matter of engineering judgment based on an analysis of the basic single line diagram and determination of the specific purpose of the study.

For the three-phase industrial and commercial power systems, the most common study is the calculation of three-phase (balanced) short circuit current which is more severe compared to other faults, specifically for comparison with switching equipment capability. The short circuit current determined from this type of study generally represents the highest value at a particular location in the system. It is important to realize that single line to ground or double line to ground short circuit current magnitude can exceed three-phase short circuit current under certain conditions. This condition may arise near,

- Solidly grounded synchronous machines.
- Solidly grounded star connection of a delta-star transformer of the three-phase core design.
- Grounded star-delta tertiary autotransformers.

- Grounded star-delta tertiary three winding transformers.

In system where any of these machines or transformer connections exists, it may be necessary to conduct a single line to ground short circuit study. Medium and high voltage circuit breakers have 15% higher interrupting capability for single line to ground short circuits than for phase to phase or three phase short circuits. This difference must be taken into account when comparing short circuit duty with equipment ratings. Further, future network growth (about 20% increases in result obtained through study) has to be accounted while considering the fault levels for equipment ratings.

5.1 Short circuit study result analysis

The detailed results of the Short circuit study for the three phases to ground fault and single line to ground faults are tabulated in Table H and presented in Annexure-III.

Based on the detailed analysis, it is observed that

- For 400 kV, 220 kV, 132 kV & 66 kV voltage levels, there are no violation in the fault level.

6 MAJOR OBSERVATIONS & CONCLUSION

Based on the operational load flow studies carried out for aforesaid condition following observation are made,

- Due to less power demand in NER, overvoltage is observed in many 400 kV, 220 kV buses.
- From the off peak load flow analysis results it is observed that the 400 & 220 kV bus voltages of the NER grid are on the higher side of the stipulated grid code. Due to under loading of transmission lines, maximum voltage observed at 400 kV and 220kV are 1.029(Palatana) and 1.05(Mariani PG) respectively.
- No overloading is observed in any of the voltage grades. Number of lines loaded between 80 to 100% of thermal capacity is 5 predominantly in 132 kV level. Numbers of lines loaded below 5% of thermal capacities are 5 at 220 kV level and 41 at 132 kV level.
- In the entire region, overloading of 4 transformers is observed. 36 no. of transformer loaded beyond 80% and 79 numbers are loaded below 20% of rated capacity which is predominantly in 132kV voltage level.
- Maximum inter regional power exchange is 522.6MW to Eastern region.
- It is observed that short circuit level for all the substations are within the rated breaking capacity of circuit breakers.

The network modeling for operational load flow and short circuit study and the results will provide the base for the subsequent protection system analysis and calculation. This database will also provide the base case to study reactive power compensation of NER grid.

**ANNEXURE-1 EXISTING NORTH EASTERN REGION TRANSMISSION
NETWORK
AND LOAD DETAILS**

Table A: State wise list of substation present in the North Eastern Region grid

Sl. No.	Name of the Substation	Voltage level (kV)	Substation Details			Owned By
			No. of units	Capacity of each unit (MVA)	Total capacity (MVA)	
Arunachal Pradesh						
220 kV Level						
1	Deomali	220/132	1	100	100	DoP
		132/33	2	16	32	
132 kV Level						
1	Nirjuli	132/33	2	50	100	PGCIL
2	Naharlagun (Lekhi)	132/33	1	15	15	DoP
		132/33	1	20	20	
3	Itanagar	132/33	2	20	40	DoP
4	Khuppi	132/33	1	20	20	DoP
5	Ziro	132/33	1	15	15	PGCIL
6	Daporijo	132/33	2	5	10	DoP
7	Along	132/33	1	15	15	DoP
8	Bhalukpong	132/11	1	30	30	DoP
9	Tezu	132/33	2	15	30	PGCIL
10	Passighat	132/33	2	10	20	DoP
11	Roing	132/33	2	15	30	PGCIL
12	Namsai	132/33	2	15	30	DoP
Assam						
800 kV Level						
1	Biswanath Chariyali HVDC	800				PGCIL
400 kV Level						
1	Azara (Kukumara/Mirza)	400/220/33	2	315	630	AEGCL
		220/132	2	50	100	
		132/33	1	25	25	
2	Balipara PG	400/220/33	2	315	630	PGCIL
		220/132	1	160	160	
		220/132	1	50	50	
3	Biswanath Chariyali	400/132	2	200	400	PGCIL
4	Silchar PG	400/132	3	200	600	PGCIL
5	Misa PG	400/220/33	2	315	630	PGCIL
6	Bongaigaon PG	400/220/33	1	315	315	PGCIL
		220/132	2	50	100	
220 kV Level						
1	Bongaigaon (BTPS) (ASEB)	220/132	2	160	320	AEGCL

Procurement of Web Based Protection Database Management Software and Protection Setting Calculation Tool for North Eastern Region

Sl. No.	Name of the Substation	Voltage level (kV)	Substation Details			Owned By
			No. of units	Capacity of each unit (MVA)	Total capacity (MVA)	
		220/132	1	100	100	
		132/33	1	16	16	
		132/6.6	2	10	20	
2	Tinsukia	220/132	2	100	200	AEGCL
		132/66	2	20	40	
		132/33	2	40	80	
		66/33	3	20	60	
		66/33	3	10	30	
3	Mariani	220/132	2	100	200	AEGCL
		132/33	2	25	50	
		132/33	1	20	20	
		66/33	2	5	10	
4	Mariani (PG)	220				PGCIL
5	Samaguri	220/132	1	100	100	AEGCL
		220/132	2	50	100	
		132/33	2	25	50	
		132/33	1	16	16	
6	Sarusajai	220/132	3	100	300	AEGCL
		132/33	3	31.5	94.5	
7	Sonapur	220/132	2	100	200	AEGCL
		132/33	1	25	25	
8	Boko	220/132	1	100	100	AEGCL
		220/132	1	50	50	
		132/33	1	40	40	
		132/33	1	16	16	
9	Agia	220/132	1	100	100	AEGCL
		220/132	1	50	50	
		132/33	1	40	40	
10	Sonabil	220/132	2	100	200	AEGCL
11	Jawaharnagar	220/33	2	50	100	AEGCL
132 kV Level						
1	Pailapool	132/33	1	10	10	AEGCL
		132/33	1	25	25	
		132/33	1	16	16	
2	Deopata (Tezpur)	132/33	2	31.5	63	AEGCL
3	Dhemaji	132/33	2	16	32	AEGCL
		132/33	1	10	10	

Procurement of Web Based Protection Database Management Software and Protection Setting Calculation Tool for North Eastern Region

Sl. No.	Name of the Substation	Voltage level (kV)	Substation Details			Owned By
			No. of units	Capacity of each unit (MVA)	Total capacity (MVA)	
4	Srikona	132/33	1	25	25	AEGCL
		132/33	1	40	40	
5	Panchgram	132/33	2	25	50	AEGCL
6	Hailakandi	132/33	2	16	32	AEGCL
		132/33	2	8	16	
7	Dullabcherra	132/33	1	25	25	AEGCL
		132/33	3	3.5	10.5	
8	Umranshu	132/33	1	16	16	AEGCL
		132/33	1	25	25	
9	Margherita (Ledo)	132/33	2	25	50	AEGCL
10	Rupai (Doomdooma)	132/33	2	25	50	AEGCL
		66/33	2	10	20	
11	Moran	132/33	2	16	32	AEGCL
12	Nazira	132/33	1	25	25	AEGCL
		66/33	2	16	32	
13	Rangia	132/33	2	25	50	AEGCL
14	Amingaon (New) / Sishugram	132/33	2	31.5	63	AEGCL
		132/33	1	40	40	
15	Dibrugarh	132/33	2	31.5	63	AEGCL
16	Sibsagar	132/33	2	16	32	AEGCL
17	Majauli	132/33	2	5.5	11	AEGCL
18	Jorhat (Garmur)	132/33	3	25	75	AEGCL
19	Golaghat	132/33	2	25	50	AEGCL
		66/33	2	10	20	
20	North Lakhimpur (Nalkata)	132/33	2	25	50	AEGCL
21	Gohpur	132/33	2	25	50	AEGCL
22	Rowta	132/33	2	25	50	AEGCL
23	Sipajhar	132/33	2	16	32	AEGCL
24	Bokajan	132/33	2	16	32	AEGCL
25	Diphu	132/33	2	16	32	AEGCL
26	Lanka (Sankardev Nagar)	132/33	2	25	50	AEGCL
27	Narengi	132/33	2	25	50	AEGCL
28	Kahilipara	132/33	1	31.5	31.5	AEGCL
		132/33	2	30	60	
		132/33	2	40	80	
29	Gosaigaon	132/33	2	16	32	AEGCL
30	Gauripur	132/33	2	25	50	AEGCL

Procurement of Web Based Protection Database Management Software and Protection Setting Calculation Tool for North Eastern Region

Sl. No.	Name of the Substation	Voltage level (kV)	Substation Details			Owned By
			No. of units	Capacity of each unit (MVA)	Total capacity (MVA)	
31	Bilashipara	132/33	2	16	32	AEGCL
32	APM Jogighopa	132/33	1	16	16	AEGCL
		132/33	1	12.5	12.5	
33	Dhaligaon	132/33	2	25	50	AEGCL
34	Bornagar	132/33	2	25	50	AEGCL
		132/33	1	40	40	
35	Nalbari	132/33	1	40	40	AEGCL
		132/33	1	16	16	
36	Kokrajhar	132/33	2	25	50	AEGCL
37	Matia (Dudhnoi)	132/33	2	25	50	AEGCL
38	Jorhat West (Panichakua)	132/33	2	40	80	AEGCL
39	Bokakhat	132/33	2	16	32	AEGCL
40	Sonari	132/33	2	25	50	AEGCL
41	Dispur	132/11	2	16	32	AEGCL
42	Ghoramari	132/33	1	40	40	AEGCL
		132/33	1	16	16	AEGCL
43	Kamalpur	132/33	2	40	80	AEGCL
44	Dhekiajuli	132/33	1	25	25	AEGCL
45	Kamakhya	132/33	2	40	80	AEGCL
46	Khaloigaon	132/33	2	25	50	AEGCL
47	Bagjhap	132/33	2	25	50	AEGCL
48	Pavoi (Biswanath Chariyali)	132/33	2	40	80	AEGCL
49	Chandrapur (CTPS)	132/33	1	30	30	AEGCL
		132/33	1	16	16	
50	Haflong	132/33	2	10	20	AEGCL
51	Behiating (Khanikar)	132/33	2	10	20	AEGCL
52	Badarpur s/w station	132				PGCIL
53	Haflong (PG)	132/33	2	10	20	PGCIL
54	Bordubi	132/33	2	25	50	AEGCL
Manipur						
132 kV Level						
1	Imphal (PG)	132/33	2	50	100	PGCIL
2	Jiribam (PG)	132 Switching				PGCIL
3	Imphal (Yurembam)	132/33	3	31.5	94.5	MSPCL
4	Karong (Senapati)	132/33	2	20	40	MSPCL
5	Jiribam (state)	132/33	1	6.3	6.3	MSPCL
		132/33	1	20	20	

Procurement of Web Based Protection Database Management Software and Protection Setting Calculation Tool for North Eastern Region

Sl. No.	Name of the Substation	Voltage level (kV)	Substation Details			Owned By
			No. of units	Capacity of each unit (MVA)	Total capacity (MVA)	
6	Churachandpur	132/33	2	20	40	MSPCL
7	Kakching	132/33	2	20	40	MSPCL
8	Ningthoukhong	132/33	2	20	40	MSPCL
9	Yaingangpokpi	132/33	2	20	40	MSPCL
10	Rengpang	132/33	1	12.5	12.5	MSPCL
11	Kongba	132/33	2	20	40	MSPCL
12	Hundung	132/33	2	12.5	25	MSPCL
13	Chandel	132/33	2	12.5	25	MSPCL
14	Elangkhangpokpi	132/33	2	20	40	MSPCL
15	Tipaimukh	132/33	2	12.5	25	MSPCL
16	Thoubal	132/33	2	20	40	MSPCL
17	Moreh	132/33	2	12.5	25	MSPCL
18	Thanlon	132/33	2	12.5	25	MSPCL
Meghalaya						
400kV Level						
1	Byrnihat (Killing)	400/220	2	315	630	MePTCL
		220/132	2	160	320	MePTCL
132kV Level						
1	Mendipather	132/33	2	20	40	MePTCL
2	Rongkhon (Tura)	132/33	2	20	40	MePTCL
		132/33	2	5	10	MePTCL
3	Nangalbibra	132/33	1	12.5	12.5	MePTCL
		132/33	1	25	25	
4	Nongstoin	132/33	1	20	20	MePTCL
5	Mawngap (Mawphlang)	132/33	2	20	40	MePTCL
6	Sohra (Cherrapunjee)	132/33	1	12.5	12.5	MePTCL
7	Mawlai	132/33	3	20	60	MePTCL
8	Umiam	132/33	2	20	40	MePTCL
9	Umiam Stg III	132/33	1	10	10	MePTCL
10	EPIP II (Norbong)	132/33	1	50	50	MePTCL
11	EPIP I (Norbong/Rajabagan)	132/33	1	20	20	MePTCL
12	Nehu	132/33	2	20	40	MePTCL
13	NEIGRIHMS	132/11	2	10	20	MePTCL
14	Mustem (Jowai)	132/33	2	20	40	MePTCL
15	Khliehriat (State)	132/33	1	20	20	MePTCL
16	Lumshnong	132/33	1	10	10	MePTCL
17	Khliehriat (PG)	132			0	PGCIL

Procurement of Web Based Protection Database Management Software and Protection Setting Calculation Tool for North Eastern Region

Sl. No.	Name of the Substation	Voltage level (kV)	Substation Details			Owned By
			No. of units	Capacity of each unit (MVA)	Total capacity (MVA)	
Mizoram						
132kV Level						
1	Aizal PGCIL	132 Switching				PGCIL
2	Khawzawl	132/33	1	12.5	12.5	P&E D Mizoram
3	Kolasib (Bawklang)	132/66	1	12.5	12.5	P&E D Mizoram
		132/33	1	12.5	12.5	
		66/33	1	6.3	6.3	
4	Luangmual	132/33	3	12.5	37.5	P&E D Mizoram
5	Saitual	132/33	1	6.3	6.3	P&E D Mizoram
6	Zungtui (Zemabawk)	132/33	4	12.5	50	P&E D Mizoram
7	Bukupui (Serchip)	132/33	1	12.5	12.5	P&E D Mizoram
		132/33	1	6.3	6.3	
8	Khawiva (Lunglei)	132/33	2	12.5	25	P&E D Mizoram
9	Keifangtlang (Champai)	132/33	1	12.5	12.5	P&E D Mizoram
10	Melriat	132/33	2	12.5	25	PGCIL
Nagaland						
220 kV Level						
1	Nagarjan Dimapur (PG)	220/132	2	100	200	PGCIL
2	Mokokchung (PG)	220/132	2	30	60	PGCIL
132 kV Level						
1	Dimapur Power house (DoP Nag)	132/66	1	100	100	DoP, Nagaland
		132/33	1	100	100	
		66/33	3	20	60	
2	Mokokchung/ Aolichen MKG	132/66	2	25	50	DoP, Nagaland
		66/33	2	7.5	15	
3	Wokha	132/33	2	5	5	DoP, Nagaland
4	Kiphire	132/66	3	10	30	DoP, Nagaland
		66/33	1	5	5	DoP, Nagaland
5	Kohima	132/33	3	8	24	DoP, Nagaland
6	Meluri	132/33	1	12	12	DoP, Nagaland

Procurement of Web Based Protection Database Management Software and Protection Setting Calculation Tool for North Eastern Region

Sl. No.	Name of the Substation	Voltage level (kV)	Substation Details			Owned By
			No. of units	Capacity of each unit (MVA)	Total capacity (MVA)	
66 kV level						
1	MON	66/33	1	7.5	7.5	DoP, Nagaland
2	Naginimora	66/33	1	5	5	DoP, Nagaland
3	Tizit	66/33	1	5	5	DoP, Nagaland
4	Tuli	66/33	2	10	20	DoP, Nagaland
5	Chumukidima	66/11	1	20	20	DoP, Nagaland
6	Dairy Farm	66/33	1	5	5	DoP, Nagaland
7	Ganeshnagar	66/33	1	10	10	DoP, Nagaland
8	Nitofarm	66/33	1	5	5	DoP, Nagaland
9	Powerhouse, Burma camp	66/11	2	10	20	DoP, Nagaland
10	Tuengsang	66/33	1	7.5	7.5	DoP, Nagaland
11	Zunheboto	66/33	1	7.5	7.5	DoP, Nagaland
Tripura						
132 kV Level						
1	Purba Kanchanbari	132/33	1	15	15	TSECL
		132/11	1	15	15	
2	Surajmani Nagar	132/33	2	50	100	TSECL
3	Dharmanagar (Mission Tilla)	132/33	3	7.5	22.5	TSECL
		132/33	1	25	25	
4	Kailasahar (Gournagar)	132/33	2	7.5	15	TSECL
		132/33	1	15	15	TSECL
5	Kumarghat (PGI)	132/33	1	5	5	PGCIL
6	Kamalpur	132/11	2	10	20	TSECL
7	Dhalabil (Khowai)	132/33	1	7.5	7.5	TSECL
		132/11	1	15	15	TSECL
8	Ambassa	132/33	1	7.5	7.5	TSECL
		132/33	1	15	15	
9	Udaipur (Banduar)	132/66	1	15	15	TSECL
		132/66	2	10	20	
		132/33	1	25	25	

Procurement of Web Based Protection Database Management Software and Protection Setting Calculation Tool for North Eastern Region

Sl. No.	Name of the Substation	Voltage level (kV)	Substation Details			Owned By
			No. of units	Capacity of each unit (MVA)	Total capacity (MVA)	
		132/11	2	15	30	TSECL
		66/33	1	10	10	
		132/33	3	15	45	
10	Agartala (79 Tilla)	132/33	2	25	50	TSECL
		132/11	2	15	30	
11	Bodhjangnagar	132/33	2	25	50	TSECL
12	Jirani	132/33	1	15	15	TSECL
		132/11	1	15	15	
13	Teliamura (Gamaitilla)	132/11	1	15	15	TSECL
		66/33	1	6.3	6.3	
		66/33	1	4	4	
14	Rabindranagar (Sonamura)	132/66	1	15	15	TSECL
		132/33	1	20	20	
		66/33	1	10	10	
		66/11	1	15	15	
66 kV Level						
1	Boxanagar	66/11	1	6.3	6.3	TSECL
2	Ompi	66/11	1	6.3	6.3	TSECL
3	Jatanbari	66/11	1	6.3	6.3	TSECL
4	Bishramgaunj	66/11	1	5	5	TSECL
5	Badharghat	66/33	2	15	30	TSECL
		66/11	2	10	20	
6	Belonia	66/33	1	10	10	TSECL
		66/11	2	6.3	12.6	
7	Bagafa	66/33	1	6.3	6.3	TSECL
		66/11	1	5	5	
		66/11	1	10	10	
8	Sabroom	66/11	1	10	10	TSECL
9	Satchand	66/11	1	4	4	TSECL
10	Amarpur	66/11	2	6.3	12.6	TSECL
11	Gakulnagar	66/11	1	15	15	TSECL

Table B: State wise list of transmission lines present in North Eastern Region grid

Sl. No.	Transmission line		Ckt type	Distance (km)	Conductor Type	Owned By
	From	To				
Arunachal Pradesh						
400kV						
1	Ranganadi	B.Chariyali(Assam)	D/C	131	Twin Moose	NEEPCO & PGCIL
2	Balipara	Kameng	D/C	57	Twin Moose	NEEPCO & PGCIL
220kV						
1	Deomali	Kathalguri(AGBPP)	S/C	19	ACSR Zebra	NEEPCO & DoP AP
132kV						
1	Bhalukpong	Balipara	S/C	45	ACSR Panther	PGCIL & DoP AP
2	Bhalukpong	Khupi	S/C	67	ACSR Panther	NEEPCO & DoP
3	Itanagar	Ranganadi	S/C	32	ACSR Panther	DoP AP & NEEPCO
4	Itanagar	Pare	S/C	31	ACSR Panther	DoP AP & NEEPCO
5	Pare	Ranganadi	S/C	9	ACSR Panther	NEEPCO & PGCIL
6	Pare	Ranganadi	S/C	6	ACSR Panther	NEEPCO & PGCIL
7	Itanagar	Naharlagun (Lekhi)	S/C	14	ACSR Panther	DoP
8	Naharlagun (Lekhi)	Pare	S/C	17	ACSR Panther	DoP AP & NEEPCO
9	Naharlagun (Lekhi)	Nirjuli	S/C	9.5	ACSR Panther	DoP AP & PGCIL
10	Nirjuli	Gohpur(Assam)	S/C	42.5	ACSR Panther	PGCIL & AEGCL
11	Ziro	Ranganadi	S/C	44.5	ACSR Panther	PGCIL
12	Ziro	Daporijo	S/C	87	ACSR Panther	PGCIL & DoP AP
13	Daporijo	Along	S/C	82	ACSR Panther	DoP AP
14	Along	Pasighat	S/C	77	ACSR Panther	DoP AP
15	Passighat	Roing	S/C	102.8	ACSR Panther	DoP AP
16	Roing	Tezu	S/C	73	ACSR Panther	PGCIL
17	Tezu	Namsai	S/C	95	ACSR Panther	PGCIL

Procurement of Web Based Protection Database Management Software and Protection Setting Calculation Tool for North Eastern Region

Sl. No.	Transmission line		Ckt type	Distance (km)	Conductor Type	Owned By
	From	To				
Assam						
800 kV						
1	Biswanath Chariyali (PG)	Agra (PG)	2 ploe	1726	Hexa Lapwing	PGCIL
400 kV						
1	Bongaigaon (PG)	Balipara (PG)	D/C	304.6	ACSR Quad Moose	PGCIL
2	Bongaigaon (PG)	Balipara (PG)	D/C	289.7	ACSR Twin Moose	PGCIL
3	Bongaigaon (PG)	Bongaigaon (BGTPP) NTPC)	D/C	3.1	ACSR Twin Moose	PGCIL
4	Bongaigaon (PG)	New Siliguri(Binaguri) (WB)	D/C	218	ACSR Twin Moose	PGCIL
5	Bongaigaon (PG)	Alipurduar (WB)	D/C	106	ACSR Quad Moose	PGCIL
6	Bongaigaon (PG)	Azara	S/C	162.9	ACSR Twin Moose	AEGCL
7	Bongaigaon (PG)	Killing (Meghalaya)	S/C	204	ACSR Twin Moose	NETC
8	Azara	Silchar (PG)	S/C	256	ACSR Twin Moose	AEGCL
9	Biswanath Chariyali (PG)	Balipara (PG)	D/C	60	ACSR Twin moose	PGCIL
10	Biswanath Chariyali (PG)	Balipara (PG)	D/C	57.1	ACSR Twin moose	PGCIL
11	Balipara (PG)	Misa (PG)	D/C	95.9	ACSR Twin Moose	PGCIL
12	Silchar (PG)	Killing (Meghalaya)	S/C	217	ACSR Twin Moose	NETC
13	Silchar (PG)	Pallatana(Tripura)	D/C	247	ACSR Twin Moose	NETC
14	Silchar (PG)	P K Bari(Tripura)	D/C	127.2	ACSR Twin Moose	PGCIL
15	Silchar (PG)	Imphal(Manipur)	D/C	166.5	ACSR Twin Moose	PGCIL
16	Kathalguri (GEN) (AGBPP)	Mariani (PG)	S/C	160.5	ACSR Twin Moose	PGCIL
17	Kathalguri (GEN) (AGBPP)	Mariani (AEGCL)	S/C	162.9	ACSR Twin Moose	PGCIL
18	Misa (PG)	Mariani (PG)	S/C	222.7	ACSR Twin Moose	PGCIL

Procurement of Web Based Protection Database Management Software and Protection Setting Calculation Tool for North Eastern Region

Sl. No.	Transmission line		Ckt type	Distance (km)	Conductor Type	Owned By
	From	To				
19	Misa (PG)	Mariani (AEGCL)	S/C	220	ACSR Twin Moose	PGCIL
220 kV						
1	Agia	Bongaigaon (BTPS) (ASEB)	D/C	62.5	AAAC Zebra	AEGCL
2	Agia	Azara (Kukumara)	S/C	107	AAAC Zebra	AEGCL
3	Agia	Boko	S/C	70	AAAC Zebra	AEGCL
4	Bongaigaon (PG) (Salakati)	Birpara (WB)	D/C	106	ACSR Zebra	PGCIL
5	Bongaigaon (PG) (Salakati)	Bongaigaon (BTPS) (ASEB)	D/C	2.7	ACSR Zebra	PGCIL
6	Bongaigaon (BGTPP) (NTPC)	Bongaigaon (BTPS) (ASEB)	D/C	4	ACSR Zebra	PGCIL
7	Azara (Kukumara)	Sarusajai	D/C	24	AAAC Zebra	AEGCL
8	Azara (Kukumara)	Boko	S/C	38	AAAC Zebra	AEGCL
9	Balipara (PG)	Sonabil	S/C	10	ACSR Zebra	AEGCL
10	Samaguri	Mariani (AEGCL)	S/C	168	ACSR Deer	AEGCL
11	Samaguri	Sonabil	D/C	56	ACSR Zebra	AEGCL
12	Samaguri	Sonapur	S/C	100.81	AAAC Zebra	AEGCL
13	Sarusajai	Sonapur	S/C	54.7	AAAC Zebra	AEGCL
14	Samaguri	Misa (PG)	D/C	34.4	ACSR Zebra	AEGCL
15	Samaguri	Jawaharnagar	S/C	119	AAAC Zebra	AEGCL
16	Sarusajai	Jawaharnagar	S/C	11	AAAC Zebra	AEGCL
17	Sarusajai	Karbi Longpi (GEN)	D/C	108	AAAC Zebra	AEGCL
18	Misa (PG)	Dimapur (PG)(Nagaland)	D/C	123.5	ACSR Zebra	PGCIL
19	Misa (PG)	Kopili (GEN)	D/C	73	ACSR Zebra	PGCIL
20	Misa (PG)	Kopili (GEN)	S/C	75.8	ACSR Zebra	PGCIL
21	Misa (PG)	Byrnihat (MEGHALAYA)	D/C	113.4	ACSR Zebra	MePTCL

Procurement of Web Based Protection Database Management Software and Protection Setting Calculation Tool for North Eastern Region

Sl. No.	Transmission line		Ckt type	Distance (km)	Conductor Type	Owned By
	From	To				
22	Mariani (PG)	Mokokchung (PG) (Nagaland)	D/C	48.8	ACSR Zebra	PGCIL
23	Tinsukia	Namrup (GEN) (NTPS)	D/C	39.8	ACSR Zebra	AEGCL
24	Tinsukia	Kathalguri (GEN) (AGBPP)	D/C	24.6	AAAC Zebra	AEGCL
25	Bongaigaon (BTPS) (ASEB)	Rangia	D/C	161	ACSR Zebra	AEGCL
132 kV						
1	Balipara (PG)	Ghoramari	S/C	29.48	ACSR Panther	AEGCL
2	Balipara (PG)	Sonabil	S/C	10	AAAC Panther	AEGCL
3	Biswanath Chariyali	Pavoi	D/C	12.9	ACSR Panther	PGCIL
4	Badarpur s/w station	Jiribam (PG) (Manipur)	S/C	67.2	AAAC Panther	PGCIL
5	Badarpur s/w station	Kolasib (Mizoram)	S/C	107.2	AAAC Panther	PGCIL
6	Badarpur s/w station	Kumarghat (Tripura)	S/C	118.5	AAAC Panther	PGCIL
7	Badarpur s/w station	Khliehriat	S/C	76.7	AAAC Panther	PGCIL
8	Badarpur s/w station	Panchgram (Badarpur)	S/C	1	AAAC Panther	PGCIL
9	Badarpur s/w station	Silchar (PG)	D/C	19.2	ACSR Panther	PGCIL
10	Pavoi	Sonabil	S/C	39	ACSR Panther	PGCIL
11	Bokajan	Dimapur (PG)(Nagaland)	S/C	26.4	ACSR Panther	AEGCL
12	Bokajan	Golaghat	S/C	15	ACSR Panther	AEGCL
13	Dhaligaon	Bongaigaon (BTPS) (ASEB)	D/C	21.5	ACSR Panther	AEGCL
14	Dullabcherra	Hailakandi	S/C	33.8	ACSR Panther	AEGCL
15	Dullabcherra	Dharmnagar (Tripura)	S/C	26	ACSR Panther	AEGCL
16	Hailakandi	Silchar (PG)	D/C	33.8	ACSR Panther	PGCIL
17	Gohpur	Pavoi	S/C	51	ACSR Panther	AEGCL
18	Gohpur	Gohpur splt	S/C	1	ACSR Panther	AEGCL
19	Gohpur splt	Nirjuli(Arunachal)	S/C	42.5	ACSR Panther	PGCIL

Procurement of Web Based Protection Database Management Software and Protection Setting Calculation Tool for North Eastern Region

Sl. No.	Transmission line		Ckt type	Distance (km)	Conductor Type	Owned By
	From	To				
20	Gohpur	North Lakhimpur	D/C	77	ACSR Panther	AEGCL
21	Gohpur	Sonabil	S/C	87.6	ACSR Panther	AEGCL
22	Golaghat	Mariani (AEGCL)	S/C	45	ACSR Panther	AEGCL
23	Haflong (PG)	Jiribam (PG)(Manipur	S/C	100.6	ACSR Panther	PGCIL
24	Haflong (PG)	Umranshu	S/C	8.2	ACSR Panther	AEGCL
25	Pailapool	Jiribam (PG) (Manipur)	S/C	15	ACSR Panther	AEGCL/MS PCL
26	Jorhat (Garmur)	Mariani	D/C	19.5	ACSR Panther	AEGCL
27	Jorhat (Garmur)	Nazira	S/C	69	ACSR Panther	AEGCL
28	Jorhat (Garmur)	Jorhat West (Panichakua)	S/C	44.6	ACSR Panther	AEGCL
29	Kamalpur	Kahilipara	S/C	32	ACSR Panther	AEGCL
30	Kamalpur	Rangia	D/C	14	ACSR Panther	AEGCL
31	Kamalpur	Amingaon (New) / Sishugram	S/C	20	ACSR Panther	AEGCL
32	Kahilipara	Sarusajai	D/C	3.5	ACSR Panther	AEGCL
33	Kahilipara	Sarusajai	S/C	3.9	ACSR Panther	AEGCL
34	Kahilipara	Umtru (Meghalaya)	D/C	11	ACSR Panther	MePTCL
35	Kopili (GEN)	Khandong (GEN)	S/C	10.9	ACSR Panther	PGCIL
36	Kopili (GEN)	Khandong (GEN)	S/C	11.6	ACSR Zebra	PGCIL
37	Lakwa (LTPS)	Nazira	D/C	22	ACSR Panther	AEGCL
38	Lakwa (LTPS)	Mariani	S/C	80	ACSR Panther	AEGCL
39	Lakwa (LTPS)	Namrup (GEN) (NTPS)	S/C	60	ACSR Panther	AEGCL
40	Lakwa (LTPS)	Moran	S/C	39	ACSR Panther	AEGCL
41	Lakwa (LTPS)	Sonari	S/C	30	ACSR Panther	AEGCL
42	Mariani (AEGCL)	Mokokchung (Nagaland)	S/C	50	ACSR Panther	AEGCL

Procurement of Web Based Protection Database Management Software and Protection Setting Calculation Tool for North Eastern Region

Sl. No.	Transmission line		Ckt type	Distance (km)	Conductor Type	Owned By
	From	To				
43	Sonari	Namrup (GEN) (NTPS)	S/C	30	ACSR Panther	AEGCL
44	Pailapool	Srikorna	S/C	34.5	ACSR Panther	AEGCL
45	Panchgram (Badarpur)	Srikorna	S/C	19.1	ACSR Panther	AEGCL
46	Sarusajai	Umtru (Meghalaya)	D/C	37	ACSR Panther	MePTCL
47	Silchar (PG)	Srikorna	D/C	1.2	ACSR Panther	PGCIL
48	Behiating	Dibrugarh	S/C	9	ACSR Panther	AEGCL
49	Behiating	Moran	S/C	47	ACSR Panther	AEGCL
50	Bilashipara	Gauripur	S/C	37.6	AAAC Panther	AEGCL
51	Bilashipara	Kokrajarh	S/C	24.2	AAAC Panther	AEGCL
52	Bongaigaon (BTPS) (ASEB)	Kokrajarh	S/C	10.3	AAAC Panther	AEGCL
53	Bornagar	Dhaligaon	S/C	41.3	ACSR Panther	AEGCL
54	Bornagar	Rangia	S/C	85.7	ACSR Panther	AEGCL
55	Jorhat West (Panichakua)	Bokakhat	S/C	89	ACSR Panther	AEGCL
56	Dhaligaon	BRPL	S/C	6	ACSR Panther	AEGCL
57	Chandrapur	Bagjhap	S/C	39	ACSR Panther	AEGCL
58	Chandrapur	Dispur	S/C	21	ACSR Panther	AEGCL
59	Chandrapur	Sonapur	S/C	14.43	ACSR Panther	AEGCL
60	Deopata (Tezpur)	Rowta	S/C	64	ACSR Panther	AEGCL
61	Deopata (Tezpur)	Sonabil	S/C	17	ACSR Panther	AEGCL
62	Deopata (Tezpur)	Ghoramari	S/C	21	ACSR Panther	AEGCL
63	Deopata (Tezpur)	Dhekiajuli	S/C	45	ACSR Panther	AEGCL
64	Dhaligaon	APM Jogighopa	S/C	37	ACSR Panther	AEGCL
65	Dhaligaon	Gosaigaon	S/C	64	ACSR Panther	AEGCL

Procurement of Web Based Protection Database Management Software and Protection Setting Calculation Tool for North Eastern Region

Sl. No.	Transmission line		Ckt type	Distance (km)	Conductor Type	Owned By
	From	To				
66	Dhaligaon	Nalbari	S/C	150	ACSR Panther	AEGCL
67	Dhemaji	North Lakhimpur	S/C	63	ACSR Panther	AEGCL
68	Dibrugarh	Tinsukia	S/C	53	ACSR Panther	AEGCL
69	Diphu	Lanka	S/C	71.6	ACSR Panther	AEGCL
70	Gauripur	Gosaigaon	S/C	63	ACSR Panther	AEGCL
71	Haflong (PG)	Haflong (AEGCL)	S/C	1	ACSR Panther	PGCIL
72	Bagjhap	HPC	S/C	5	ACSR Panther	AEGCL
73	Umranshu	Khandong (GEN)	S/C	11	ACSR Panther	AEGCL
74	Khandong PG	Khliehriat PG	D/C	40.9+42.5	ACSR Panther	PGCIL
75	Panchgram (Badarpur)	Lumshnong	S/C	23.4	ACSR Panther	AEGCL
76	Majuli	North Lakhimpur	S/C	45	ACSR Panther	AEGCL
77	Nalbari	Rangia	S/C	22	ACSR Panther	AEGCL
78	Rangia	Sipajhar	S/C	38.2	ACSR Panther	AEGCL
79	Kamakya	Amingaon (New) / Sishugram	S/C	4.6	ACSR Panther	AEGCL
80	Rowta	Sipajhar	S/C	44.4	ACSR Panther	AEGCL
81	Rangia	Rowta	S/C	108	ACSR Panther	AEGCL
82	Samaguri	Khaloigaon	S/C	42	ACSR Panther	AEGCL
83	Samaguri	Lanka	D/C	60	ACSR Panther	AEGCL
84	Nazira	Sibsagar	S/C	13	ACSR Panther	AEGCL
85	Tinsukia	Ledo	S/C	22	ACSR Panther	AEGCL
86	Agia	Mendipather (Meghalaya)	S/C	31	ACSR Panther	AEGCL
87	Sonapur	Narengi	S/C	30.43	ACSR Panther	AEGCL
88	Tinsukia	Bordubi	S/C	14.06	ACSR Panther	AEGCL

Procurement of Web Based Protection Database Management Software and Protection Setting Calculation Tool for North Eastern Region

Sl. No.	Transmission line		Ckt type	Distance (km)	Conductor Type	Owned By
	From	To				
89	Tinsukia	Rupai	S/C	40	ACSR Panther	AEGCL
90	Namrup (GEN) (NTPS)	Bordubi	S/C	30.03	ACSR Panther	AEGCL
91	Bongaigaon (PG) (Salakati)	Gelyphu (Bhutan)	S/C	49.2	ACSR Panther	AEGCL
92	Rangia	Deothang (Bhutan)	S/C	56.67	ACSR Panther	AEGCL
93	Dispur	Kahilipara	S/C	3	ACSR Panther	AEGCL
66 kV						
1	Golaghat	Mariani	S/C	40	ACSR Dog	AEGCL
2	Nazira	Mariani	D/C	56	ACSR Dog	AEGCL
3	Nazira	Namrup (GEN) (NTPS)	D/C	78	ACSR Dog	AEGCL
4	Rupai	Tinsukia	S/C	27	ACSR Dog	AEGCL
Manipur						
132kV						
1	Imphal(PG)	Dimapur(PG)(Nagaland)	S/C	168.9	ACSR Panther	PGCIL
2	Imphal(PG)	Imphal(Yurembam)	S/C	1.5	ACSR Panther	PGCIL
3	Imphal(PG)	Imphal(Yurembam)	S/C	2.3	Panther	PGCIL/MS PCL
4	Ningthoukhong	Imphal(PG)	S/C	27.5	ACSR Panther	MSPCL
5	Imphal(PG)	Loktak	S/C	35	ACSR Panther	PGCIL
6	Imphal (MSPCL)	Karong	S/C	60	ACSR Panther	MSPCL
7	Imphal(MSPCL)	Yaingangpokpi	D/C	42	ACSR Panther	MSPCL
8	Karong	Kohima	S/C	50	ACSR Panther	MSPCL (65.3%) / DoP, Nagaland (34.7%)
9	Loktak	Jiribam(PG)	S/C	82.4	ACSR Panther	PGCIL
10	Rengpang	Jiribam(PG)	S/C	40	ACSR Panther	MSPCL
11	Jiribam (PG)	Jiribam (State)	S/C	1	ACSR Panther	MSPCL
12	Jiribam	Tipaimukh	S/C	77	ACSR Panther	PGCIL

Procurement of Web Based Protection Database Management Software and Protection Setting Calculation Tool for North Eastern Region

Sl. No.	Transmission line		Ckt type	Distance (km)	Conductor Type	Owned By
	From	To				
13	Tipaimukh	Aizal	S/C	95	ACSR Panther	PGCIL
14	Loktak	Rengpang	S/C	35	ACSR Panther	MSPCL
15	Loktak	Ningthoukhong	S/C	10.5	ACSR Panther	MSPCL
16	Ningthoukhong	Churachandpur	D/C	23	ACSR Panther	MSPCL
17	Churachandpur	Kakching	S/C	38	ACSR Panther	MSPCL
18	Churachandpur	Elangkhangpokpi	S/C	26	ACSR Panther	MSPCL
19	Kakchin	Elangkhangpokpi	S/C	12	ACSR Panther	MSPCL
20	Yaingangpokpi	Kongba	S/C	33	ACSR Panther	MSPCL
21	Kakching	Chandel	S/C	25	ACSR Panther	MSPCL
22	Yaingangpokpi	Hundung	S/C	26.8	ACSR Panther	MSPCL
23	Kakching	Moreh	S/C	55	ACSR Panther	MSPCL
24	Kakching	Thoubal	D/C	27.5	ACSR Panther	MSPCL
25	Thoubal	Kongba	D/C	30	ACSR Panther	MSPCL
26	Churachandpur	Thanlon	S/C	53.925	ACSR Panther	MSPCL
27	Thoubal	Moreh	S/C	25	ACSR Panther	MSPCL
Meghalaya						
132 kV						
1	Nangalbibra	Mendipather	S/C	65.2	ACSR Panther	MePTCL
2	Nangalbibra	Rongkhon (Tura)	S/C	68.71	ACSR Panther	MePTCL
3	Nongstoin	Nangalbibra	S/C	57.1	ACSR Panther	MePTCL
4	Mawngap (Mawphlang)	Nongstoin	S/C	56.3	ACSR Panther	MePTCL
5	Mawngap (Mawphlang)	Sohra (Cherrapunjee)	S/C	42.14	ACSR Panther	MePTCL
6	Mawngap (Mawphlang)	Umiam Stage I	D/C	33.1	ACSR Panther	MePTCL
7	Mawngap (Mawphlang)	Mawlai	S/C	20.9	ACSR Panther	MePTCL

Procurement of Web Based Protection Database Management Software and Protection Setting Calculation Tool for North Eastern Region

Sl. No.	Transmission line		Ckt type	Distance (km)	Conductor Type	Owned By
	From	To				
8	Umiam Stage I	Mawlai	S/C	12.1	ACSR Panther	MePTCL
9	Umiam Stage I	Umiam Stage II	S/C	3	ACSR Panther	MePTCL
10	Umiam Stage I	Umiam	S/C	5.06	ACSR Panther	MePTCL
11	Umiam Stage I	Umiam Stage III	D/C	17.54	ACSR Panther	MePTCL
12	Umiam Stage III	Umiam Stage IV	D/C	9.69+8.02	ACSR Panther	MePTCL
13	Umiam Stage III	Umtru	D/C	41.11	ACSR Panther	MePTCL
14	Umiam Stage IV	Umtru	D/C	29.9	ACSR Panther	MePTCL
15	Umiam	Nehu	S/C	6.2	ACSR Panther	MePTCL
16	Umtru	EPIP II (Norbong)	D/C	0.7	ACSR Panther	MePTCL
17	Umtru	New Umtru	S/C	0.5	ACSR Panther	MePTCL
18	Umtru	Sarusajai (AS)	D/C	37	ACSR Panther	MePTCL
19	Umtru	Kahilipara (AS)	D/C	11	ACSR Panther	MePTCL
20	EPIP II (Norbong)	New Umtru	S/C	1.2	ACSR Panther	MePTCL
21	EPIP II (Norbong)	EPIP I	D/C	3.03	ACSR Panther	MePTCL
22	Byrnihat (Killing)	EPIP II (Norbong)	D/C	10.3	ACSR Panther	MePTCL
23	Byrnihat (Killing)	EPIP I	D/C	8.68	ACSR Panther	MePTCL
24	Byrnihat (Killing)	Saipraka	S/C	4.44	ACSR Panther	MePTCL
25	EPIP II (Norbong)	Trishul (132kV load)	D/C	0.44	ACSR Panther	MePTCL
26	EPIP II (Norbong)	Nalari (132kV load)	S/C	0.12	ACSR Panther	MePTCL
27	EPIP I	Greystone (132kV load)	S/C	0.3	ACSR Panther	MePTCL
28	EPIP I	Maithon Alloy (132kV load)	S/C	0.44	ACSR Panther	MePTCL
29	EPIP I	Shayam Century (132kV load)	S/C	0.3	ACSR Panther	MePTCL
30	EPIP I	Sai Prakash (132kV load)	S/C	4.4	ACSR Panther	MePTCL

Procurement of Web Based Protection Database Management Software and Protection Setting Calculation Tool for North Eastern Region

Sl. No.	Transmission line		Ckt type	Distance (km)	Conductor Type	Owned By
	From	To				
31	Mawlai	Nehu	S/C	7.9	ACSR Panther	MePTCL
32	Nehu	NEIGRIHMS	S/C	6.7	ACSR Panther	MePTCL
33	Nehu	Mustem (Jowai)	S/C	41.9	ACSR Panther	MePTCL
34	Mustem (Jowai)	Khliehriat(State)	S/C	15.7	ACSR Panther	MePTCL
35	NEIGRIHMS	Khliehriat(State)	S/C	62.8	ACSR Panther	MePTCL
36	Khliehriat	Lumsnong	S/C	23.8	ACSR Panther	MePTCL
37	Khliehriat(State)	Myntdu Leshka	D/C	26.5	ACSR Panther	MePTCL
38	Khliehriat	Khliehriat PG	S/C+S/C	7.8+5.4	ACSR Panther	PGCIL
39	Lumsnong	MPL (132kV load)	S/C	0.3	ACSR Panther	PGCIL
40	Lumsnong	GVIL Cement (132kV load)	S/C	2.18	ACSR Panther	MePTCL
41	Lumsnong	CMCL (132kV load)	S/C	0.3	ACSR Panther	MePTCL
42	Lumsnong	MCL (132kV load)	S/C	3.3	ACSR Panther	MePTCL
43	Lumsnong	Adhunik Cement (132kV load)	S/C	3.6	ACSR Panther	MePTCL
44	Lumsnong	Hill Cement (132kV load)	S/C	5.5	ACSR Panther	MePTCL
45	Lumsnong	JUD Cement (132kV load)	D/C	1.9	ACSR Panther	MePTCL
46	EPIP I	Adhunik Meghalaya Steels (P) Ltd.	S/C	0.09	ACSR Panther	MePTCL
47	EPIP II	Meghalaya Sova Ispat Alloys Pvt. Ltd.	D/C	0.1	ACSR Panther	MePTCL
48	Umiam	RNB Cements	S/C	0.32	ACSR Panther	MePTCL
49	Mawlai	Sohra/cherra	S/C	42.1	ACSR Panther	MePTCL
50	EPIP I	Meghalaya Carbide Ltd (Disconnected)	D/C	0.3	ACSR Panther	MePTCL
51	EPIP I	Pioner Carbide	S/C	1.6	ACSR Panther	MePTCL
52	Nehu	Leska	S/C	105.5	ACSR Panther	MePTCL

Procurement of Web Based Protection Database Management Software and Protection Setting Calculation Tool for North Eastern Region

Sl. No.	Transmission line		Ckt type	Distance (km)	Conductor Type	Owned By
	From	To				
53	Line tapping to Nezone Industries		S/C	0.32	ACSR Panther	MePTCL
Mizoram						
132 kV						
1	Kumarghat PGCIL(Tripura)	Aizal PG	S/C	132.9	ACSR Panther	PGCIL
2	Jiribam PGCIL (Manipur)	Aizal PG	S/C	172.3	ACSR Panther	PGCIL
3	Aizal PG	Luangmual (Mizoram)	S/C	0.8	ACSR Panther	P&E D Mizoram
4	Zuangtui	Bukpui	S/C	54	ACSR Panther	P&E D Mizoram
5	Bukpui(Serchip)	Khawiva(Lunglei)	S/C	55	ACSR Panther	P&E D Mizoram
6	Zuangtui(Zemabaw k)	Khawzawl	S/C	148	ACSR Panther	P&E D Mizoram
7	Saitual	Khawzawl	S/C	43	ACSR Panther	P&E D Mizoram
8	Bairabi	Bawktlang (Kolasib)	S/C	30.01	ACSR Panther	P&E D Mizoram
9	Kolasib	Tuirial	S/C	0.7	ACSR Panther	P&E D Mizoram
10	Kolasib	Aizal PG	S/C	66.1	ACSR Panther	PGCIL
11	Aizal PG	Melriat-PG	S/C	6.7	ACSR Panther	PGCIL
12	Khawzawl	Champhai	S/C	18	ACSR Panther	P&E D Mizoram
13	Zuangtui(Zemabaw k)	Saitual	S/C	50	ACSR Panther	P&E D Mizoram
14	Zuangtui	Melriat-PG	S/C	10.2	ACSR Panther	PGCIL
Nagaland						
132 kV						
1	MELURI	Kiphire (132kV)	S/C	42	ACSR Panther	Dop, Nagaland
2	Kohima	Meluri(132kV)	S/C	74	ACSR Panther	Dop, Nagaland
3	Kohima	Wokha(132kV)	S/C	58	ACSR Panther	Dop, Nagaland
4	Mokokchung(PG)	Mokokchung(Dop, Nagaland)	D/C	1.4	ACSR Panther	PGCIL
5	Mokokchung(Dop, Nagaland)	Doyang(Neepco)	S/C	30	ACSR Panther	Dop, Nagaland

Procurement of Web Based Protection Database Management Software and Protection Setting Calculation Tool for North Eastern Region

Sl. No.	Transmission line		Ckt type	Distance (km)	Conductor Type	Owned By
	From	To				
6	Doyang(Neepeco)	SANIS(Dop, nagaland)	S/C	6.4	ACSR Panther	Dop, Nagaland
7	Doyang(Neepeco)	Dimapur-PG(132kV)	D/C	92.5	ACSR Panther	PGCIL
8	DIMAPUR- PG	Dimapur(Dop,Nagaland)	S/C	0.5	ACSR Panther	Dop, Nagaland
9	DIMAPUR- PG	Dimapur(Dop,Nagaland)	S/C	0.5	ACSR Panther	Dop, Nagaland
10	Sanis(Dop,nagaland)	wokha(Dop,nagaland)	S/C	26.7	ACSR Panther	Dop, Nagaland.A EGCL
11	Dimapur -PG	Kohima (LILO)(132kV)	S/C	45	ACSR Panther	Dop, Nagaland
12	Kohima	Karong (Manipur)	S/C	50	ACSR Panther	MSPCL (65.3%) / DoP, Nagaland (34.7%)
66 kV						
1	Kiphire	Likhimro I & II	D/C	36	ACSR Dog	Dop, Nagaland
2	Mon	Tizit	S/C	31	ACSR Dog	Dop, Nagaland
3	Naginmora	Tizit	S/C	44	ACSR Dog	Dop, Nagaland
4	Naginmora	Tuli	S/C	34	ACSR Dog	Dop, Nagaland
5	Mokokchung(Dop Nagaland)	Tuli	S/C	56.3	ACSR Dog	Dop, Nagaland
6	Mokokchung(Dop Nagaland)	Tuensang	S/C	48.7	ACSR Dog	Dop, Nagaland
7	Mokokchung(Dop Nagaland)	Zunheboto	S/C	42.8	ACSR Dog	Dop, Nagaland
8	Chumukdema	Singrijan	S/C	8	ACSR Dog	Dop, Nagaland
9	Dairy Farm	Nito Farm	S/C	11.6	ACSR Dog	Dop, Nagaland
10	Power House	Dairy Farm	S/C	4.89	ACSR Dog	Dop, Nagaland
11	Ganeshnagar	Singrijan	S/C	21.4	ACSR Dog	Dop, Nagaland
12	Dimapur(DoP Nagaland)	Power House (dimapur, burma camp)	S/C	2.7	ACSR Dog	Dop, Nagaland
13	Kiphire	Tuensang	S/C	56.09	ACSR Dog	Dop, Nagaland

Procurement of Web Based Protection Database Management Software and Protection Setting Calculation Tool for North Eastern Region

Sl. No.	Transmission line		Ckt type	Distance (km)	Conductor Type	Owned By
	From	To				
14	Dimapur (DoP Nagaland)	Singrijan	D/C	5.4	ACSR Dog	Dop, Nagaland
Tripura						
400 kV						
1	Paltana	Surajmani Nagar	S/C	37.2	ACSR Quad Moose	PGCIL
2	Surajmani Nagar	Comila(North)	D/C	47	Twin Moose(INDIA SIDE)/Twin Finch(BANGLADESH SIDE)	PGCIL
132 kV						
1	Dharmanagar (Mission Tilla)	P.K.Bari	S/C	36.5	ACSR Panther	TSECL
2	P.K.Bari	Kailasahar	S/C	18	ACSR Panther	TSECL
3	P.K.Bari	Kumarghat(PG)	S/C	1	ACSR Panther	TSECL
4	Kumarghat(Pgcil)	AGTPP	S/C	7.8	ACSR Panther	PGCIL
5	Khowai(Dhalabil)	Kamalpur	S/C	32	ACSR Panther	TSECL
6	Khowai(Dhalabil)	Agartala	S/C	45	ACSR Panther	TSECL
7	Kamalpur	P.K.Bari	S/C	31	ACSR Panther	TSECL
8	Kamalpur	Ambasa	S/C	31	ACSR Panther	TSECL
9	Agartala (79 Tilla)	Surajmani Nagar	D/C	18	ACSR Panther	TSECL
10	Ambassa	P.K.Bari	S/C	45	ACSR Panther	TSECL
11	Ambassa	Gamatilla/Teliamura	S/C	25	AAAC Panther	TSECL
12	Gamatilla/Teliamura	Baramura	S/C	14	ACSR Panther	TSECL
13	Baramura	Jirania	S/C	12.6	AAAC Panther	TSECL
14	Jirania	Bodhjung Nagar	S/C	13.5	AAAC Panther	TSECL
15	Bodhjung Nagar	Surajmaninagar	D/C	18.3	AAAC Panther	TSECL
16	Agartala	Bodhjung Nagar	S/C	8	AAAC Panther	TSECL

Procurement of Web Based Protection Database Management Software and Protection Setting Calculation Tool for North Eastern Region

Sl. No.	Transmission line		Ckt type	Distance (km)	Conductor Type	Owned By
	From	To				
17	Agartala	AGTPP	D/C	8.4	AAAC Panther	PGCIL
18	Agartala	Rokhia	D/C	35	ACSR Panther	TSECL
19	Udaipur	Monarchak	S/C	41.5	ACSR Panther	TSECL
20	Rokhia	Monarchak	S/C	29	ACSR Panther	TSECL
21	Monarchak	Rabindranagar	D/C	3	AASC Panther	TSECL
22	Palatan	Udaipur	S/C	11.1	ACSR Panther	TSECL
66 kV						
1	Agartala (PG)	Baramura	S/C	25	ACSR Dog	TSECL
2	Badharghat	Agartala (PG)	S/C	5	ACSR Dog	TSECL
3	Baramura	Teliamura	S/C	12	ACSR Dog	TSECL
4	Teliamura	Ompi	S/C	17	ACSR Dog	TSECL
5	Ompi	Amarpur	S/C	18	ACSR Dog	TSECL
6	Amarpur	Gumti	S/C	24	ACSR Dog	TSECL
7	Gumti	Jatanbari	S/C	11	ACSR Dog	TSECL
8	Jatanbari	Udaipur	S/C	34	ACSR Dog	TSECL
9	Udaipur	Bisramgaunj	S/C	15.96	ACSR Dog	TSECL
10	Bisramgaunj	Gakulnagar	S/C	15.04	ACSR Dog	TSECL
11	Udaipur	Bagafa	S/C	25	ACSR Dog	TSECL
12	Bagafa	Satchand	S/C	22	ACSR Dog	TSECL
13	Bagafa	Belonia	S/C	15	ACSR Dog	TSECL
14	Satchand	Sabroom	S/C	15	ACSR Dog	TSECL
15	Belonia	Sonamura (Rabindranagar)	S/C	40	ACSR Dog	TSECL
16	Sonamura (Rabindranagar)	Rokhia	S/C	22.5	ACSR Dog	TSECL
17	Rokhia	Badharghat	S/C	24	ACSR Dog	TSECL
18	Badharghat	Gakulnagar	S/C	12	ACSR Dog	TSECL
19	Rokhia	Boxanagar	S/C	3.48	ACSR Dog	TSECL

Table C: State wise list of generators present in the North Eastern Region grid

Sl. No.	Name of the Power Station	Type of Generation	Generator details			Owned By
			No. of units	Capacity of each unit (MW)	Total capacity (MW)	
Arunachal Pradesh						
Central Sector						
1	Ranganadi	Hydro	3	135	405	NEEPCO
2	Pare	Hydro	2	55	110	NEEPCO
Assam						
Central Sector						
1	Bongaigaon (NTPC) (BgTPP)	Thermal	2	250	500	NTPC
2	Kathalguri (AGBPP) 400/220	Gas	5	33	165	NEEPCO
		Thermal	2	30	60	
3	Kopili	Hydro	4	50	200	NEEPCO
4	Lower Kopili	Hydro	1	25	25	NEEPCO
5	Khandong	Hydro	2	25	50	NEEPCO
State Sector						
1	Namrup (NTPS) 220/132/66/33	Gas	1	20	20	APGCL & AEGCL
			2	21	42	
			1	11	11	
			1	24	24	
			1	22.5	22.5	
2	Karbi Longpi	Hydro	2	50	100	APGCL
3	LTPS (Lakwa), LRPP	Thermal	1	37.2	37.2	APGCL & AEGCL
		Gas	3	20	60	
		Gas	7	10	70	
Manipur						
Central Sector						
1	Loktak	Hydro	3	35	105	NHPC
Meghalaya						
State Sector						
1	Uiam Stage I(Sumer)	Hydro	4	9	36	MePGCL
2	Uiam Stage II (Umsumer)	Hydro	2	10	20	MePGCL
3	Uiam Stage III(Kydremkulai)	Hydro	2	30	60	MePGCL
4	Uiam Stage IV(Nongkhyllem)	Hydro	2	30	60	MePGCL
5	MLHEP (Myntdu Leshka)	Hydro	1	42	42	MePGCL
6	Umtru	Hydro	4	2.8	11.2	MePGCL
7	New Umtru	hydro	2	20	40	MePGCL

Procurement of Web Based Protection Database Management Software and Protection Setting Calculation Tool for North Eastern Region

Sl. No.	Name of the Power Station	Type of Generation	Generator details			Owned By
			No. of units	Capacity of each unit (MW)	Total capacity (MW)	
CPP						
1	MPL	Thermal	1	8	8	-
		Thermal	1	43.15	43.15	-
2	Adhunik	Thermal	1	25	25	-
3	Shyam Century	Thermal	1	13.8	13.8	-
4	Maithon Alloys	Thermal	1	15	15	-
Mizoram						
Central Sector						
1	Turial	Hydro	2	30	60	NEEPCO
State Sector						
2	Bairabi	Hydro	4	5.7	22.8	P&E D Mizoram
Nagaland						
Central Sector						
1	Doyang	Hydro	3	25	75	NEEPCO
State Sector						
2	Likimro	Hydro	3	8	24	Dop, Nagaland
Tripura						
Central Sector						
1	Ramchandranagar/ AGTPP	Gas based	4	21	84	NEEPCO
		Thermal	2	25	50	
2	Monarchak	Gas based	1	65.5	65.5	NEEPCO
			1	35.58	35.58	
3	Palatana	Gas based	1	232.39	232.39	OTPC(ONGC)
		Thermal	1	130.91	130.91	OTPC(ONGC)
		Gas based	1	232.39	232.39	OTPC(ONGC)
		Thermal	1	130.91	130.91	OTPC(ONGC)
State Sector						
1	Rokhia	Thermal	3	21	63	TPGL
2	Gumti	Hydro	3	5	15	TPGL
4	Baramura	Gas based	1	21	21	TPGL
			1	21	21	

Table D: State wise list of Bus reactors present in the North Eastern Region grid

Sl. No.	Name of the Substation	Voltage level (kV)	Existing reactor details			Owner
			no of units	Capacity of each unit (MVar)	Total capacity (MVar)	
Arunachal Pradesh						
1	Ziro	132	1	20	20	PGCIL
2	Roing	132	1	20	20	PGCIL
3	Tezu	132	1	20	20	PGCIL
4	Ranganadi	33	1	80	80	NEEPCO
Assam						
1	Biswanath Chariyali	400	1	80	80	PGCIL
			1	80	80	PGCIL
2	Azara	400	1	63	63	AEGCL
3	Balipara (PG)	400	1	125	125	PGCIL
4			1	80	80	PGCIL
5			1	50	50	PGCIL
6		33	4	25	100	PGCIL
7	Bongaigaon (PG)	400	1	125	125	PGCIL
8			1	80	80	PGCIL
9			1	80	80	PGCIL
10			1	50	50	PGCIL
11		1	50	50	PGCIL	
12		33	2	25	50	PGCIL
13	Silchar (PG)	400	1	63	63	PGCIL
14			1	63	63	PGCIL
15	Misa (PG)	400	1	50	50	PGCIL
16		33	4	25	100	PGCIL
17	Mariani (AEGCL)	220	1	12.5	12.5	AEGCL
18		220	1	12.5	12.5	AEGCL
19	Samaguri	220	1	12.5	12.5	AEGCL
20		220	1	12.5	12.5	AEGCL
Manipur						
1	Imphal(PG)	132	1	20	20	PGCIL
Meghalaya						
1	Byrnihat (Killing)	400	1	63	63	PGCIL
Mizoram						
1	Aizawl	132	1	20	20	PGCIL
Tripura						
1	Palatana	400	1	80	80	OTPC
2	Dharmanagar	132	1	2	2	TSECL

Sl. No.	Name of the Substation	Voltage level (kV)	Existing reactor details			Owner
			no of units	Capacity of each unit (MVar)	Total capacity (MVar)	
		132	1	2	2	TSECL
3	Kumarghat (PG)	132	1	20	20	PGCIL

Table E: State wise list of line reactor present in the North Eastern Region grid

Sl. No.	Name of the transmission line		From side		To side	
	From	To	Rating (in MVar)	Owner	Rating (in MVar)	Owner
400 kV						
1	Bongaigaon (PG)	Azara	63	PGCIL	NA	NA
2	Bongaigaon (PG)	Balipara (PG)	63	PGCIL	63	PGCIL
3	Bongaigaon (PG)	Balipara (PG)	63	PGCIL	63	PGCIL
4	Bongaigaon (PG)	Balipara (PG)	50	PGCIL	63	PGCIL
5	Bongaigaon (PG)	Balipara (PG)	50	PGCIL	63	PGCIL
6	Bongaigaon (PG)	New Siliguri (WB)	63	PGCIL	NA	NA
7	Bongaigaon (PG)	New Siliguri (WB)	63	PGCIL	NA	NA
8	Bongaigaon (PG)	Byrnihat	63	PGCIL	NA	NA
9	Silchar (PG)	Palatana	50	PGCIL	63	OPTC
10	Silchar (PG)	Palatana	50	PGCIL	63	OPTC
11	Silchar (PG)	Azara	63	PGCIL	63	AEGCL
12	Silchar (PG)	Byrnihat	63	PGCIL	50	MePTCL
13	Balipara (PG)	Biswanath Chariwali	50	PGCIL	NA	NA
14	Balipara (PG)	Biswanath Chariwali	50	PGCIL	NA	NA
15	Balipara (PG)	Misa (PG)	NA	NA	50	PGCIL
16	Biswanath Chariwali	Ranganadi	NA	NA	50	NEEPCO
17	Biswanath Chariwali	Ranganadi	NA	NA	50	NEEPCO
220 kV						
1	Kathalguri (GEN) (AGBPP)	Mariani (PG)	20	NEEPCO	NA	NA
2	Misa (PG)	Mariani (PG)	50	PGCIL	NA	NA

Line Reactor used as Bus Reactor						
400 kV						
Sl. No.	Name of the transmission line		From side		To side	
	From	To	Rating (in MVar)	Owner	Rating (in MVar)	Owner
1	Biswanath Chariwali	Subansiri	63	PGCIL	NA	NA
2	Biswanath Chariwali	Subansiri	63	PGCIL	NA	NA

Table F: State wise list of load data considered for the study present in the North Eastern Region grid

Sl. No.	Name of the SubStation	Voltage level (kV)	Substation details			33 or 11kV lump load	
			No. of units	Capacity of each unit (MVA)	Total capacity (MVA)	MW	MVAr
Arunachal Pradesh							
1	Nirjuli	132/33	2	50	100	13.30	4.37
2	Tezu	132/33	2	15	30	0.16	0.05
3	Roing	132/33	2	15	30	0.18	0.06
4	Ziro	132/33	1	15	15	0.64	0.21
5	Naharlagun(Lekhi)	132/33	1	15	15	22.60	4.71
			1	20	20		
6	Itanagar	132/33	2	20	40	19.51	4.88
7	Khuppi	132/33	1	20	20	1.13	0.37
8	Daporijo	132/33	2	5	10	5.50	1.70
9	Along	132/33	1	15	15	11.50	3.78
10	Deomali	132/33	2	16	32	3.55	1.17
11	Bhalukpong	132/33	1	30	30	12.70	4.17
12	Passighat	132/33	2	10	20	13.80	4.54
13	Namsai	132/33	2	15	30	0.42	0.14
Assam							
1	Azara (Kukurmara)	132/33	1	25	25	4.99	1.64
2	Sonapur	132/33	1	25	25	4.18	1.37
3	Biswanath Chariyali	132/33	2	40	80	18.44	1.30
4	Bongaigaon (BTPS) (ASEB)	132/33	1	16	16	2.85	0.94
5	Tinsukia	132/33	2	40	80	34.53	10.10
6	Mariani	132/33	2	25	50	24.96	4.70
		132/33	1	20	20		
		66/33	2	5	10		
7	Samaguri	132/33	2	25	50	52.97	12.70
		132/33	1	16	16		
8	Sarusajai	132/33	3	31.5	94.5	52.97	17.41
9	Boko	132/33	1	40	40	29.95	3.00
		132/33	1	16	16		
10	Agia	132/33	1	40	40	31.68	3.30
11	Rangia	132/33	2	25	50	27.81	3.20
12	Amingaon (New) / Sishugram	132/33	2	31.5	63	49.50	16.27
		132/33	1	40	40		
13	Dibrugarh 220/132	132/33	3	31.5	94.5	25.46	6.80
14	Jawaharnagar	220/33	2	50	100	21.75	7.32
15	Pailapool	132/33	1	16	16	20.78	4.10
			1	25	25		
			1	10	10		
16	Deopata (Tezpur)	132/33	2	31.5	63	21.80	8.00
17	Dhemaji	132/33	2	16	32	24.45	8.04
			1	10	10		
18	Srikona	132/33	1	25	25	37.08	11.50
			1	40	40		

Procurement of Web Based Protection Database Management Software and Protection Setting Calculation Tool for North Eastern Region

Sl. No.	Name of the SubStation	Voltage level (kV)	Substation details			33 or 11kV lump load	
			No. of units	Capacity of each unit (MVA)	Total capacity (MVA)	MW	MVAr
19	Panchgram	132/33	2	25	50	36.06	9.80
20	Hailakandi	132/33	2	16	32	19.25	4.26
21	Dullabcherra	132/33	1	25	25	12.32	2.12
			1	10.5	10.5		
22	Umranshu	132/33	1	16	16	2.04	0.67
			1	25	25		
23	Margherita	132/33	2	25	50	19.46	3.80
24	Rupai (Doomdooma)	132/33	2	25	50	22.51	4.80
		66/33	2	10	20		
25	Moran	132/33	2	16	32	14.77	2.50
26	Nazira	132/33	1	25	25	28.52	1.56
		66/33	2	16	32		
27	Sibsagar	132/33	2	16	32	11.20	3.20
28	Majauli	132/33	1	11	11	5.40	1.77
		132/33	2	16	32		
29	Jorhat (Garmur)	132/33	3	25	75	28.52	7.60
30	Golaghat	132/33	2	25	50	27.91	6.00
		66/33	2	10	20		
31	North Lakhimpur	132/33	2	25	50	26.69	1.10
32	Gohpur	132/33	2	25	50	16.30	2.80
33	Rowta	132/33	2	25	50	24.45	5.60
34	Sipajhar	132/33	2	16	32	25.06	5.80
35	Bokajan	132/33	2	16	32	14.26	3.00
36	Diphu	132/33	2	16	32	7.44	2.44
37	Lanka (Sankardev Nagar)	132/33	2	25	50	42.98	14.13
38	Narengi	132/33	2	25	50	25.87	11.00
39	Kahilipara	132/33	1	31.5	31.5	67.33	22.13
		132/33	2	30	60		
		132/33	2	40	80		
40	Gosaigaon	132/33	2	16	32	18.91	4.17
41	Gauripur	132/33	2	25	50	48.28	7.00
42	Bilashipara	132/33	2	16	32	10.19	1.80
43	APM Jogighopa	132/33	1	16	16	14.87	2.00
		132/33	1	12.5	12.5		
44	Dhaligaon	132/33	2	25	50	24.85	4.20
45	Bornagar	132/33	2	25	50	39.73	3.60
		132/33	1	40	40		
46	Nalbari	132/33	1	40	40	36.16	5.73
		132/33	1	16	16		
47	Kokrajhar	132/33	2	25	50	9.62	1.73
48	Jorhat West (Panichakua)	132/33	2	40	80	11.20	2.57
49	Bokakhat	132/33	2	16	32	13.24	3.50
50	Sonari	132/33	2	25	50	12.83	4.22
51	Dispur	132/11	2	16	32	3.06	1.10
52	Ghoramari	132/33	1	40	40	8.35	2.75
		132/33	1	16	16		
53	Kamalpur	132/33	1	40	40	16.91	4.20
54	Dhekiajuli	132/33	1	25	25	12.32	4.05

Procurement of Web Based Protection Database Management Software and Protection Setting Calculation Tool for North Eastern Region

Sl. No.	Name of the SubStation	Voltage level (kV)	Substation details			33 or 11kV lump load	
			No. of units	Capacity of each unit (MVA)	Total capacity (MVA)	MW	MVA
55	Kamakhya	132/33	2	40	80	2.24	0.74
56	Khaloigaon	132/33	2	25	50	39.73	13.06
57	Bagjhap	132/33	2	25	50	14.94	3.21
58	Pavoi	132/33	2	40	80	0.00	0.00
59	Chandrapur (CTPS)	132/33	1	30	30	9.88	3.25
		132/33	1	16	16		
60	Haflong	132/33	2	10	20	6.72	2.21
61	Behiating	132/33	2	10	20	8.76	2.88
62	Haflong (PG)	132/33	2	10	20	0.00	0.00
63	Bordubi	132/33	2	25	50	12.12	3.98
64	Lakwa	132/33	2	7.5	15	5.60	1.84
65	Namrup	66/33	2	10	20	12.22	4.02
Industrial Load							
66	BRPL					5.09	1.67
67	HPC					0.51	0.17
68	HPC Private					0.20	0.07
Manipur							
1	Imphal(PG)	132/33	2	50	100	16.73	1.56
2	Jiribam (PG)	132/33	1	20	20	2.50	0.82
3	Imphal(Yurembam)	132/33	3	31.5	94.5	44.55	6.60
4	Karong(Senapati)	132/33	2	20	40	18.47	1.76
5	Jiribam (state)	132/33	1	6.3	6.3	2.72	0.89
		132/33	1	20	20		
6	Churachandpur	132/33	2	20	40	17.49	5.75
7	Kakching	132/33	2	20	40	6.40	4.09
8	Ningthoukhong	132/33	2	20	40	9.13	3.00
9	Yaingangpokpi	132/33	2	20	40	7.86	1.50
10	Rengpang	132/33	1	12.5	12.5	1.85	0.61
11	Kongba	132/33	2	20	40	19.12	6.28
12	Hundung	132/33	2	12.5	25	5.76	1.89
13	Chandel	132/33	2	12.5	25	2.17	0.71
14	Elangkhangpokpi	132/33	2	20	40	5.69	1.87
15	Tipaimukh	132/33	2	12.5	25	0.00	-1.30
16	Thoubal	132/33	2	20	40	5.49	1.80
17	Moreh	132/33	2	12.5	25	2.77	0.91
18	Thanlon	132/33	2	12.5	25	0.32	-2.30
Meghalaya							
1	Mendipather	132/33	2	20	40	13.78	-8.80
2	Rongkhon (Tura)	132/33	2	20	40	35.41	11.64
		132/33	2	5	10		
3	Nangalbibra	132/33	1	12.5	12.5	10.98	3.61
		132/33	1	25	25		
4	Nongstoin	132/33	1	20	20	12.27	4.03
5	Mawngap (Mawphlang)	132/33	2	20	40	32.29	-8.20
6	Sohra (Cherrapunjee)	132/33	1	12.5	12.5	0.00	0.00
7	Mawlai	132/33	3	20	60	47.90	13.94
8	Umiam	132/33	2	20	40	17.01	4.60
9	Umiam Stg III	132/33	1	10	10	6.46	1.40

Procurement of Web Based Protection Database Management Software and Protection Setting Calculation Tool for North Eastern Region

Sl. No.	Name of the SubStation	Voltage level (kV)	Substation details			33 or 11kV lump load	
			No. of units	Capacity of each unit (MVA)	Total capacity (MVA)	MW	MVAr
10	EPIP II (Norbong)	132/33	1	50	50	17.22	5.66
11	EPIP I (Norbong/Rajabagan)	132/33	2	20	40	9.26	3.04
12	Nehu	132/33	2	20	40	20.88	4.48
13	NEIGRIHMS	132/11	2	10	20	5.49	-1.11
14	Mustem (Jowai)	132/33	2	20	40	18.31	-6.90
15	Khliehriat(S)	132/33	1	20	20	14.33	4.71
16	Lumshnong	132/33	1	10	10	1.94	0.64
Industrial Load							
17	RNB_Cement					0.00	0.00
18	Trisul					0.00	0.00
19	Nalari					12.43	1.54
20	Megh_Sova Ishpat					0.00	0.00
21	Grey Stone					0.00	0.00
22	Megha Carbide					0.00	0.00
23	Maithon Ishpat					13.35	4.39
24	Shayam Cement					15.50	5.09
25	Saiprakash Alloy					0.00	0.00
26	Adhunik Steel					0.00	0.00
27	Pioneer Carbide					5.81	1.91
28	MPL					16.20	5.32
29	GVIL					6.42	2.11
30	CMCL					0.00	0.00
31	MCL					0.43	0.14
32	Adhunik					14.29	4.70
33	Hill Cement					6.35	2.09
34	JFud					4.20	1.38
Mizoram							
1	Melriat	132/33	2	12.5	25	3.44	1.13
2	Bairabi	132/33	1	3	3	1.64	0.54
3	Khawzawl	132/33	1	12.5	12.5	3.87	1.27
4	Kolasib (Bawklang)	132/33	1	12.5	12.5	5.01	1.65
		66/33	1	6.3	6.3		
5	Luangmual	132/33	3	12.5	37.5	21.40	7.03
6	Saitual	132/33	1	6.3	6.3	3.12	1.02
7	Zungtui(Zemabawk)	132/33	4	12.5	50	36.33	11.94
8	Bukupui (Serchip)	132/33	1	12.5	12.5	0.37	0.12
		132/33	1	6.3	6.3		
9	Khawiva(Lunglei)	132/33	2	12.5	25	8.47	2.78
10	Keifangtlang(Champai)	132/33	1	12.5	12.5	2.36	0.78
Nagaland							
1	Dimapur Power house(DoP)	132/33	1	100	100	25.80	8.48
		66/33	3	20	60		
2	Mokokchung/ Aolichen MKG	66/33	2	7.5	15	6.92	2.27
3	SANIS/Doyang	132/33	1	12.5	12.5	1.21	0.40
4	WOKHA	132/33	2	5	5	5.53	1.82
5	Kiphire	66/33	1	5	5	3.67	1.21
6	Kohima	132/33	3	8	24	22.61	7.43

Procurement of Web Based Protection Database Management Software and Protection Setting Calculation Tool for North Eastern Region

Sl. No.	Name of the SubStation	Voltage level (kV)	Substation details			33 or 11kV lump load	
			No. of units	Capacity of each unit (MVA)	Total capacity (MVA)	MW	MVA
7	Meluri	132/33	1	12	12	4.34	1.43
8	MON	66/33	1	7.5	7.5	2.20	0.72
9	Naganimora	66/33	1	5	5	2.74	0.90
10	Tizit	66/33	1	5	5	2.20	0.72
11	Tuli	66/33	2	10	20	8.78	2.89
12	Chumukidima	66/11	1	20	20	7.13	2.35
13	Dairy Farm	66/33	1	5	5	2.54	0.83
14	Ganeshnagar	66/33	1	10	10	5.10	1.68
15	Nitofarm	66/33	1	5	5	2.27	0.75
16	Powerhouse, Burma camp	66/11	2	10	20	9.46	3.11
17	Tuengsang	66/33	1	7.5	7.5	6.37	2.09
18	Zunheboto	66/33	1	7.5	7.5	6.15	2.02
Tripura							
1	Purba kanchanbari	132/33	1	15	15	9.50	3.12
		132/11	1	15	15	3.70	1.22
2	Surajmani nagar	132/33	2	50	100	10.30	3.39
3	Dharmanagar (Mission tilla)	132/33	3	7.5	22.5	15.50	5.09
		132/33	1	25	25		
4	Kailasahar(Gournagar)	132/33	2	7.5	15	3.64	1.20
		132/11	1	15	15	4.70	1.54
5	Kumarghat PG	132/33	1	5	5	0.00	0.00
6	Kamalpur	132/11	2	10	20	4.80	1.58
7	Dhalabil(Khowai)	132/11	1	7.5	7.5	7.50	2.47
		132/11	1	15	15		
8	Ambassa	132/33	1	7.5	7.5	4.40	1.45
		132/33	1	15	15		
9	Udaipur (Banduar)	132/33	1	25	25	3.20	1.05
		66/33	1	10	10		
		132/11	2	15	30	5.70	1.87
10	Agartala (79 tilla)	132/33	3	15	45	31.10	10.22
		132/33	2	25	50		
		132/11	2	15	30	6.70	2.20
11	Badharghat	66/33	1	15	15	0.00	0.00
		66/33	1	10	10		
		66/11	2	10	20	12.30	4.04
12	Bodhjangnagar	132/33	2	25	50	2.77	0.91
13	Jirani	132/33	1	10	10	6.30	2.07
		132/11	1	15	15	4.88	1.60
14	Baramura	66/11	1	5	5	0.00	0.00
15	Rokhia	66/11	1	6.3	6.3	1.70	0.56
16	Belonia	66/33	1	10	10	6.50	2.14
		66/11	1	4	4	6.50	2.14
		66/11	1	6.3	6.3		
17	Bagafa	66/33	2	10	20	6.00	1.97
18	Sabroom	66/11	1	10	10	2.50	0.82
19	Teliamura (Gamaitilla)	132/11	1	15	15	6.25	2.05
		66/11	1	10	10		
		66/33	1	6.3	6.3	2.30	0.76

Procurement of Web Based Protection Database Management Software and Protection Setting Calculation Tool for North Eastern Region

Sl. No.	Name of the SubStation	Voltage level (kV)	Substation details			33 or 11kV lump load	
			No. of units	Capacity of each unit (MVA)	Total capacity (MVA)	MW	MVA
20	Satchand	66/11	1	6.3	6.3	2.50	0.82
21	Amarpur	66/11	2	6.3	12.6	3.50	1.15
22	Gakulnagar	66/11	1	15	15	3.75	1.23
23	Rabindranagar(sonamura)	132/33	1	20	20	13.20	4.34
		66/33	1	10	10		
		66/11	1	15	15	5.70	1.87
24	Boxnagar	66/11	1	6.3	6.3	2.90	0.95
25	OMPI	66/11	1	6.3	6.3	2.50	0.82
26	Jatanbari	66/11	1	6.3	6.3	5.90	1.94
		66/11	1	4	4		
27	Bishramgaunj	66/11	1	5	5	2.50	0.82
28	Gumti	66/33	1	4	4	1.50	0.49

**ANNEXURE-II LINE LOADING DETAILS AND POWER MAP OF NER GRID
AND ITS CONSTITUENTS STATES AND SLD OF NER GRID**

Table G: 400 kV, 220 kV, 132 kV and 66 kV line flow (simulated result) of North Eastern Region grid

Sl.No	No. of ckt	From Station	To Station	FORWARD		LOSS		% LOADING
				MW	MVA _r	MW	MVA _r	
Arunachal Pradesh								
400 kV								
1	1	RANGANADI	B. CHARIALI	170.082	4.604	0.6752	-20.9513	18.2
2	1	RANGANADI	B. CHARIALI	170.082	4.604	0.6752	-20.9513	18.2
220 kV								
3	1	DEOMALI	AGBPP	-3.553	-1.221	0.0003	-2.9475	1.7
132 kV								
4	1	BHALUKPONG	BALIPARA	-13.875	-1.949	0.0815	-2.1005	15.6
5	1	BHALUKPONG	KHUPPI	1.135	-3.013	0.0019	-3.3929	3.6
6	1	ITANAGAR	RANGANADI	-2.11	-3.354	0.0032	-1.6381	4.4
7	1	ITANAGAR	PARE	-18.606	-4.134	0.1025	-1.3587	21
8	1	PARE	RANGANADI	0	0	0	-0.464	0
9	1	PARE	RANGANADI	0	0	0	-0.3093	0
10	1	ITANAGAR	LEKHI	1.153	1.569	0.0007	-0.7162	2.8
11	1	LEKHI	PARE	-34.853	-8.102	0.2007	-0.4006	39.3
12	1	LEKHI	NIRJULI	13.33	4.176	0.0174	-0.4443	15.6
13	1	NIRJULI	GOHPUR SPLIT	LINE	IS	OPEN	0	0
14	1	ZIRO	RANGANADI	-34.125	10.655	0.5378	-1.0067	40.3
15	1	ZIRO	DAPORIJO	33.481	-10.87	0.9643	-2.1262	38.9
16	1	DAPORIJO	ALONG	27.005	-10.687	0.6205	-2.6433	32.3
17	1	ALONG	PASSIGHAT	14.843	-7.723	0.1854	-3.4134	18.7
18	1	PASSIGHAT	ROING	0.812	1.025	0.0133	-5.0661	6.9
19	1	ROING	TEZU	0.599	-1.021	0.0007	-3.5789	3
20	1	TEZU	NAMSAI1	0.422	-4.524	0.0046	-4.6613	5.1
Assam								
400 kV								
1	1	BALIPARA	MARIANI PG	55.349	-33.723	0.0532	-7.5947	6.9
2	1	BALIPARA	MARIANI PG	55.349	-33.723	0.0532	-54.8376	6.9
3	1	B. CHARIALI	BALIPARA	165.657	-26.318	0.295	15.8178	18.1
4	1	B. CHARIALI	BALIPARA	165.657	-26.318	0.295	15.8178	18.1
5	1	B. CHARIALI	BALIPARA	174.071	33.621	0.31	29.9986	18.8
6	1	B. CHARIALI	BALIPARA	174.071	-25.935	0.31	-29.5572	18.7
7	1	BALIPARA	BONGAIGAON PG	98.931	-8.954	0.5191	-54.01	11.6
8	1	BALIPARA	BONGAIGAON PG	98.931	-68.449	0.5191	-113.5055	12.8
9	1	BALIPARA	BONGAIGAON PG	116.143	-89.211	0.3997	-154.084	8.2

Procurement of Web Based Protection Database Management Software and Protection Setting Calculation Tool for North Eastern Region

Sl.No	No. of ckt	From Station	To Station	FORWARD		LOSS		% LOADING
				MW	MVA _r	MW	MVA _r	
10	1	BALIPARA	BONGAIGAON PG	116.143	-89.211	0.3997	-154.084	8.2
11	1	BGTPP	BONGAIGAON PG	90.588	-34.934	0.0053	-1.6878	10.4
12	1	BGTPP	BONGAIGAON PG	90.588	-34.934	0.0053	-1.6878	10.4
13	1	BONGAIGAON PG	ALIPURDUAR	154.75	-61.679	0.2506	-71.1905	9.4
14	1	BONGAIGAON PG	ALIPURDUAR	154.75	-61.679	0.2506	-71.1905	9.4
15	1	BONGAIGAON PG	BINAGURI	96.686	7.359	0.3782	-59.6846	12.7
16	1	BONGAIGAON PG	BINAGURI	96.686	-50.679	0.3782	-117.7226	12.7
17	1	BONGAIGAON PG	AZARA	20.785	-59.03	0.018	-91.9717	6.7
18	1	AZARA	SILCHAR	-121.208	-19.619	0.6857	-21.0988	13.1
19	1	SILCHAR	Pallatana_GEN	-215.386	-6.104	2.0567	-13.3667	22.9
20	1	SILCHAR	Pallatana_GEN	-215.386	-6.104	2.0567	-13.3667	22.9
21	1	BONGAIGAON PG	KILLING/BYRNIHAT	-42.199	-11.347	0.0719	-56.9251	6.6
22	1	BALIPARA	KAMENG	LINE	IS	OPEN	0	0
23	1	BALIPARA	KAMENG	LINE	IS	OPEN	0	0
220 kV								
24	1	MISA	MARIANI PG	-17.743	4.252	0.1133	7.9803	1.9
25	1	MISA	MARIANI	-0.948	-30.616	0.0182	-38.3219	3.3
26	1	MARIANI PG	AGBPP	-48.019	-5.164	0.2151	-7.3534	5
27	1	MARIANI	AGBPP	-69.566	-20.128	0.4604	-24.3267	7.6
28	1	AGBPP	TINSUKIA	47.695	11.698	0.0856	-3.3464	21.3
29	1	AGBPP	TINSUKIA	47.695	11.698	0.0856	-3.3464	21.3
30	1	TINSUKIA	NAMRUP	7.679	-0.957	0.0036	-6.1015	4
31	1	TINSUKIA	NAMRUP	7.679	-0.957	0.0036	-6.1015	4
32	1	AGIA	BTPS AEGCL	-22.445	-5.335	0.0481	-8.7726	10.2
33	1	AGIA	BTPS AEGCL	-22.445	-5.335	0.0481	-8.7726	10.2
34	1	AGIA	AZARA	-31.363	-6.47	0.1607	-14.6281	14.3
35	1	AGIA	BOKO	-20.521	-4.71	0.045	-9.867	9.3
36	1	BGTPP	Birpara	10.571	-25.718	0.0701	-15.213	12.2
37	1	BGTPP	Birpara	10.571	-25.718	0.0701	-15.213	12.2
38	1	BGTPP	BTPS AEGCL	43.706	21.695	0.0098	-0.3392	21.6
39	1	BGTPP	BTPS AEGCL	43.706	21.695	0.0098	-0.3392	21.6
40	1	BTPS	BTPS AEGCL	121.141	-15.469	0.0904	-0.0976	53.8
41	1	BTPS	BTPS AEGCL	121.141	-15.469	0.0904	-0.0976	53.8
42	1	AZARA	SARUSAJAI	27.233	0.385	0.0271	-3.3395	12.1
43	1	AZARA	SARUSAJAI	27.233	0.385	0.0271	-3.3395	12.1
44	1	AZARA	BOKO	50.792	-4.26	0.1483	-4.72	22.4
45	1	BALIPARA	SONABIL	88.64	9.115	0.1197	-0.8178	39.1
46	1	SAMAGURI	MARIANI	-19.223	-24.164	0.1315	-24.0792	13.6

Procurement of Web Based Protection Database Management Software and Protection Setting Calculation Tool for North Eastern Region

Sl.No	No. of cks	From Station	To Station	FORWARD		LOSS		% LOADING
				MW	MVA _r	MW	MVA _r	
47	1	SAMAGURI	SONABIL	-52.197	-0.979	0.233	-6.8685	23.2
48	1	SAMAGURI	SONABIL	LINE	IS	OPEN	0	0
49	1	SAMAGURI	SONAPUR	50.261	-10.088	0.3887	-12.4134	22.6
50	1	SARUSAJAI	SONAPUR	6.162	9.845	0.019	-7.7757	8.3
51	1	SAMAGURI	MISA	-81.731	-1.226	0.3498	-3.1215	36.1
52	1	SAMAGURI	MISA	-81.731	-1.226	0.3498	-3.1215	36.1
53	1	SAMAGURI	JAWAHARNAGAR	38.466	-16.716	0.2799	-15.7134	18.5
54	1	JAWAHARNAGAR	SARUSAJAI	16.406	-8.993	0.0056	-1.5639	8.2
55	1	SARUSAJAI	KARBI LONGPI	-49.33	-14.796	0.4062	-13.726	22.7
56	1	MISA	DIMAPUR	25.617	-9.617	0.1224	-17.2562	12
57	1	MISA	DIMAPUR	25.617	-9.617	0.1224	-17.2562	12
58	1	MISA	KOPI LI	-39.609	-27.772	0.2284	-9.5988	21.3
59	1	MISA	KOPI LI	-39.609	-27.772	0.2284	-9.5988	21.3
60	1	MISA	KOPI LI	-38.146	-27.147	0.22	-10.0587	20.6
61	1	MISA	KILLING/BYRNIHAT	15.456	-10.786	0.042	-16.2795	8.3
62	1	MISA	KILLING/BYRNIHAT	15.456	-10.786	0.042	-16.2795	8.3
63	1	MARIANI PG	MOKOKCHUNG	15.081	0.718	0.017	-7.5283	7.3
64	1	MARIANI PG	MOKOKCHUNG	15.081	0.718	0.017	-7.5283	7.3
65	1	BTPS AEGCL	RANGIA	32.3	-12.484	0.2549	-21.8225	15.3
66	1	BTPS AEGCL	RANGIA	32.3	-12.484	0.2549	-21.8225	15.3
67	1	SARUSAJAI	KARBI LONGPI	-49.33	-14.796	0.4062	-13.726	22.7
132 kV								
68	1	SILCHAR	IMPHAL PG	45.019	-2.552	0.5708	-3.7362	4.8
69	1	SILCHAR	IMPHAL PG	0	0	0.0074	-10.07	1.1
70	1	SILCHAR	PKBARI	-0.728	3.086	0.0106	-7.5507	1.2
71	1	SILCHAR	PKBARI	-0.728	3.086	0.0106	-7.5507	1.2
72	1	BALIPARA	GHORAMARI	27.744	7.647	0.2292	-0.9484	32.2
73	1	BALIPARA	SONABIL	6.805	7.135	0.0093	-0.4899	11.3
74	1	B. CHARIYALI	PAVOI	52.829	6.69	0.332	0.1198	58.2
75	1	B. CHARIYALI	PAVOI	52.829	6.69	0.332	0.1198	58.2
76	1	BADARPUR	KHLIEHERIAT	1.226	-4.511	0.0057	-3.9224	5.2
77	1	BADARPUR	PANCHGRAM	50.589	8.48	0.0244	0.0071	56.7
78	1	BADARPUR	SILCHAR	-36.433	1.797	0.2376	-0.422	40.4
79	1	BADARPUR	SILCHAR	-36.433	1.797	0.2376	-0.422	40.4
80	1	PAVOI	SONABIL	25.21	-6.081	0.2375	-1.4365	28.6
81	1	BOKAJAN	DIMAPUR	-7.772	-4.341	0.0184	-1.2919	9.9
82	1	BOKAJAN	GOLAGHAT	-6.52	0.72	0.0062	-0.7415	7.4
83	1	DHALIGAON	BTPS	-74.787	-8.697	1.1904	1.7685	85.3

Procurement of Web Based Protection Database Management Software and Protection Setting Calculation Tool for North Eastern Region

Sl.No	No. of cks	From Station	To Station	FORWARD		LOSS		% LOADING
				MW	MVAr	MW	MVAr	
84	1	DHALIGAON	BTPS	-74.787	-8.697	1.1904	1.7685	85.3
85	1	DULABCHHERA	HAILAKANDI	-10.333	-9.497	0.0586	-1.5604	15.7
86	1	HAILAKANDI	SILCHAR	-14.85	-6.666	0.0803	-1.5412	18.1
87	1	HAILAKANDI	SILCHAR	-14.85	-6.666	0.0803	-1.5412	18.1
88	1	GOHPUR	PAVOI	-76.606	-14.119	3.1887	5.1062	90.4
89	1	GOHPUR	LAKHIMPUR_NORTH	60.29	10.528	3.0196	3.8815	71.5
90	1	GOHPUR	LAKHIMPUR_NORTH	LINE	IS	OPEN	0	0
91	1	GOHPUR	SONABIL	LINE	IS	OPEN	0	0
92	1	GOLAGHAT	MARIANI	-31.289	-5.113	0.4214	-1.3074	34.9
93	1	HALFLONG	UMRANGSHU	-21.249	2.803	0.0343	-0.3473	23.5
94	1	JORHAT	MARIANI	-11.159	-7.262	0.0305	-0.9413	14.6
95	1	JORHAT	MARIANI	-11.159	-7.262	0.0305	-0.9413	14.6
96	1	JORHAT	NAZIRA	-31.173	4.32	0.639	-2.0915	35.3
97	1	JORHAT	JORHAT	24.897	1.122	0.2558	-1.6707	27.4
98	1	KAMALPUR	KAHILIPARA	-38.462	-1.494	0.4524	-0.5338	43.1
99	1	KAMALPUR	RANGIA	-15.479	-6.514	0.0371	-0.6102	18.8
100	1	KAMALPUR	RANGIA	-15.479	-6.514	0.0371	-0.6102	18.8
101	1	KAMALPUR	AMINGAON	52.462	9.305	0.5442	0.3155	59.8
102	1	KAHILIPARA	SARUSAJAI	-37.786	-2.661	0.0468	-0.0673	41.9
103	1	KAHILIPARA	SARUSAJAI	-37.786	-2.661	0.0468	-0.0673	41.9
104	1	KAHILIPARA	SARUSAJAI	-33.911	-2.408	0.042	-0.0991	37.6
105	1	KAHILIPARA	UMTRU	0	-0.561	0	-0.5606	0.6
106	1	KAHILIPARA	UMTRU	0	-0.561	0	-0.5606	0.6
107	1	LAKWA	NAZIRA	32.888	-0.094	0.2106	-0.6717	35.5
108	1	LAKWA	NAZIRA	32.888	-0.094	0.2106	-0.6717	35.5
109	1	LAKWA	MARIANI	34.065	-7.424	0.8411	-2.2344	37.6
110	1	LAKWA	NAMRUP	-7.334	0.583	0.0311	-3.1496	8.9
111	1	LAKWA	MORAN	28.933	1.228	0.2906	-1.377	31.3
112	1	LAKWA	SONARI	-0.89	2.912	0.0039	-1.5973	5
113	1	MARIANI	MOKOKCHUNG	0.001	-2.614	0.0008	-2.614	2.9
114	1	SONARI	NAMRUP	-13.751	-0.156	0.0505	-1.4882	14.9
115	1	PAILAPOOL	SRIKONA	-36.038	11.597	0.4632	-0.6764	42.4
116	1	PANCHGRAM	SRIKONA	LINE	IS	OPEN	0	0
117	1	SARUSAJAI	UMTRU	LINE	IS	OPEN	0	0
118	1	SARUSAJAI	UMTRU	LINE	IS	OPEN	0	0
119	1	SILCHAR	SRIKONA	36.871	-6.716	0.0155	-0.0252	41.2
120	1	SILCHAR	SRIKONA	36.871	-6.716	0.0155	-0.0252	41.2

Procurement of Web Based Protection Database Management Software and Protection Setting Calculation Tool for North Eastern Region

Sl.No	No. of cks	From Station	To Station	FORWARD		LOSS		% LOADING
				MW	MVA _r	MW	MVA _r	
121	1	BEHIATING	DIBRUGARH	4.98	-1.537	0.0022	-0.4604	5.7
122	1	BEHIATING	MORAN	-13.76	-1.732	0.0818	-2.2535	15.2
123	1	BILASHIPARA	GAURIPUR	43.476	3.502	0.7079	-0.091	49.7
124	1	BILASHIPARA	KOKRAJHAR	-53.676	-5.632	0.6935	0.4665	61.4
125	1	BTPS	KOKRAJHAR	64.405	8.532	0.4089	0.4568	72.3
126	1	BARANAGAR	DHALIGAON	-39.864	-1.48	0.6654	-0.3856	46
127	1	BARANAGAR	RANGIA	LINE	IS	OPEN	0	0
128	1	JORHAT	BOKAKHAT	13.426	0.011	0.1551	-4.0556	15.7
129	1	DHALIGAON	BRPL_IND	5.096	1.391	0.0017	-0.2871	6.1
130	1	CHANDRAPUR	BAGJHAP	15.566	1.742	0.0842	-1.9299	17.1
131	1	CHANDRAPUR	DISPUR	LINE	IS	OPEN	0	0
132	1	CHANDRAPUR	SONAPUR	-25.459	-5.237	0.0836	-0.5987	27.7
133	1	TEZPUR	ROWTA	51.809	11.255	1.7544	1.1666	59.7
134	1	TEZPUR	SONABIL	-67.034	-16.847	0.7792	1.0009	77.6
135	1	TEZPUR	GHORAMARI	-19.073	-6.538	0.0808	-0.8509	22.7
136	1	TEZPUR	DHEKIAJULI	12.447	2.971	0.0743	-2.0226	15.2
137	1	DHALIGAON	APM JOGIGHOPA	14.997	1.174	0.083	-1.5856	17.3
138	1	DHALIGAON	GOSAIGAON	25.253	-0.741	0.3997	-2.1047	28.7
139	1	DHALIGAON	NALBARI	38.783	8.539	2.4248	-0.8711	45.1
140	1	DIBRUGARH	TINSUKIA	-20.552	-4.173	0.2093	-2.2808	23.1
141	1	DIPHU	LANKA	-7.447	-2.632	0.0394	-3.4013	9
142	1	GAURIPUR	GOSAIGAON	-5.861	-3.529	0.025	-2.8789	7.9
143	1	HALFLONG	HALFLONG_AEGCL	6.733	2.358	0.0005	-0.0512	7.8
144	1	BAGJHAP	HPC_IND	0.509	-0.103	0	-0.271	0.6
145	1	PANCHGRAM	LUMSHNONG	14.116	-5.027	0.0476	-1.0809	16.6
146	1	MAJALI	LAKHIMPUR_NORTH	-5.408	-1.876	0.0163	-1.755	7.2
147	1	NALBARI	RANGIA	LINE	IS	OPEN	0	0
148	1	RANGIA	SIPAJHAR	LINE	IS	OPEN	0	0
149	1	KAMAKHYA	AMINGAON	-2.242	-0.747	0.0002	-0.2215	2.7
150	1	ROWTA	SIPAJHAR	25.52	7.025	0.3375	-1.1404	32
151	1	RANGIA	ROWTA	LINE	IS	OPEN	0	0
152	1	SAMAGURI	KHALOIGAON	40.775	18.041	0.7915	-0.1922	49.3
153	1	SAMAGURI	LANKA	25.744	2.568	0.3789	-2.1055	28.6
154	1	NAZIRA	SIBSAGAR	11.24	2.929	0.016	-0.649	12.8
155	1	TINSUKIA	MARGHERITA	19.584	3.806	0.0792	-0.9737	21.9
156	1	AGIA	MENDIPATHER	64.539	7.044	1.2485	1.4631	72.7
157	1	SONAPUR	NARANGI	26.193	11.863	0.2205	-1.1408	31.3
158	1	TINSUKIA	BORDUBI	-18.024	6.641	0.047	-0.6354	21.1

Procurement of Web Based Protection Database Management Software and Protection Setting Calculation Tool for North Eastern Region

Sl.No	No. of cks	From Station	To Station	FORWARD		LOSS		% LOADING
				MW	MVA _r	MW	MVA _r	
159	1	TINSUKIA	RUPAI	18.241	3.102	0.1251	-1.8066	20.6
160	1	NAMRUP	BORDUBI	30.461	-3.907	0.2485	-1.0143	33.1
161	1	SAMAGURI	LANKA	25.744	2.568	0.3789	-2.1055	28.6
162	1	DHEMAJI	LAKHIMPUR_NORTH	-24.554	-4.369	0.4824	-1.31	31.5
163	1	GOHPUR	GOHPUR SPLIT	LINE	IS	OPEN	0	0
164	1	BONGAIGAON	GEYLFHU_BHUTAN	19.093	-9.817	0.1881	-2.2213	23.1
165	1	BADARPUR	JIRIBAMPG	12.211	-9.128	0.1273	-3.1461	16.9
166	1	HALFLONG	JIRIBAMPG	14.516	-5.161	0.1984	-4.7474	16.9
167	1	KOPILI	KHANDONG_GEN	20.187	-11.388	0.0523	-0.4478	25.3
168	1	KOPILI	KHANDONG_GEN	18.969	-10.737	0.0492	-0.4921	23.8
169	1	UMRANGSHU	KHANDONG_GEN	-23.321	2.468	0.055	-0.4461	25.7
170	1	PANCHGRAM	HPC P	0.204	-0.035	0	-0.1021	0.2
171	1	KAHILIPARA	DISPUR	3.058	0.979	0.0003	-0.1522	3.6
172	1	RANGIA	DEOTHANG_BHUTAN	5.015	-1.152	0.0135	-2.7985	5.9
66 kV								
173	1	GOLAGHAT	MARIANI	-3.233	-1.136	0.0276	-0.439	12.8
174	1	NAZIRA	MARIANI	LINE	IS	OPEN	0	0
175	1	NAZIRA	MARIANI	LINE	IS	OPEN	0	0
176	1	NAZIRA	NAMRUP	-3.175	0.232	0.0491	-0.8892	12.4
177	1	NAZIRA	NAMRUP	-3.175	0.232	0.0491	-0.8892	12.4
178	1	DOOMDOOMA	TINSUKIA	-4.443	-0.836	0.0321	-0.2869	16.5
Manipur								
132 kV								
1	1	IMPHAL PG	DIMAPUR	LINE	IS	OPEN	0	0
2	1	IMPHAL PG	YUREMBAM	62.106	-3.31	0.0544	0.0536	69.1
3	1	IMPHAL PG	YUREMBAM	40.504	-2.192	0.0355	-0.0319	45.1
4	1	KAKCHIN	IMPHAL PG	LINE	IS	OPEN	0	0
5	1	IMPHAL PG	LOKTAK	-74.914	-2.675	1.8433	2.5661	83.2
6	1	YUREMBAM	KARONG	18.713	0.143	0.1989	-2.5217	20.8
7	1	YUREMBAM	YAINGAANGPOKPI	0	-2.124	0.0004	-2.124	2.4
8	1	YUREMBAM	YAINGAANGPOKPI	39.113	1.335	0.6058	-0.6451	43.5
9	1	LOKTAK	JIRIBAMPG	-18.624	16.798	0.5181	-3.0918	30.4
10	1	JIRIBAMPG	PAILAPOOL	-15.172	8.27	0.0422	-0.6717	19.5
11	1	RENGPANG	JIRIBAM	LINE	IS	OPEN	0	0
12	1	JIRIBAMPG	JIRIBAM	2.718	0.874	0.0001	-0.0513	3.2
13	1	JIRIBAMPG	TIPAIMUKH	17.212	3.492	0.2315	-3.3324	20.6
14	1	LOKTAK	RENGPANG	1.849	-1.236	0.0011	-1.8678	2.4

Procurement of Web Based Protection Database Management Software and Protection Setting Calculation Tool for North Eastern Region

Sl.No	No. of cks	From Station	To Station	FORWARD		LOSS		% LOADING
				MW	MVAr	MW	MVAr	
15	1	LOKTAK	KAKCHIN	44.405	2.287	0.1845	-0.1196	48.1
16	1	KAKCHIN	CHURACHANDPR	17.542	-0.409	0.0635	-1.0626	19.1
17	1	KAKCHIN	CHURACHANDPR	17.542	-0.409	0.0635	-1.0626	19.1
18	1	CHURACHANDPR	KAKCHIN	7.647	-0.406	0.0202	-1.9435	8.5
19	1	CHURACHANDPR	ELANGKHANGPOKP I	9.449	0.225	0.0212	-1.3128	10.4
20	1	KAKCHIN	ELANGKHANGPOKP I	-3.729	-0.201	0.0015	-0.6236	4.1
21	1	KAKCHIN	THOUBAL	LINE	IS	OPEN	0	0
22	1	YAINGAANGPOKPI	KONGBA	24.868	-0.429	0.1984	-1.1264	28.1
23	1	KAKCHIN	CHANDEL	2.175	-0.572	0.0011	-1.3029	2.5
24	1	YAINGAANGPOKPI	HUNDUNG	5.774	0.74	0.0092	-1.2839	6.9
25	1	KAKCHIN	THOUBAL	LINE	IS	OPEN	0	0
26	1	THOUBAL	KONGBA	LINE	IS	OPEN	0	0
27	1	THOUBAL	KONGBA	-5.491	-1.894	0.0094	-1.4157	6.6
28	1	KAKCHIN	MOREH	2.776	-1.923	0.004	-2.8619	3.7
29	1	CHURACHANDPR	MOREH	0.328	-5.112	0.0067	-2.8294	5.6
30	1	THOUBAL	MOREH	LINE	IS	OPEN	0	0
Meghalaya								
400 kV								
1	1	KILLING/BYRNIHAT	SILCHAR	-87.597	-22.886	0.3035	-15.1314	9.7
132 kV								
2	1	NANGALBIBRA	MENDIPATHER	-47.736	-12.469	1.7472	1.2229	58.9
3	1	NANGALBIBRA	RONGKHON	36.734	7.992	1.1031	-0.1737	45.6
4	1	NONGSTOIN	NANGALBIBRA	LINE	IS	OPEN	0	0
5	1	MAWNGAP	NONGSTOIN	12.407	2.394	0.0902	-2.5613	15
6	1	MAWNGAP	SOHRA	LINE	IS	OPEN	0	0
7	1	MAWNGAP	UMIAM STAGE 1	-17.178	0.427	0.0935	-1.4359	19.4
8	1	MAWNGAP	UMIAM STAGE 1	-17.178	0.427	0.0935	-1.4359	19.4
9	1	MAWNGAP	MAWLAI	-10.482	2.189	0.0233	-0.9877	12.3
10	1	UMIAM STAGE 1	MAWLAI	28.997	1.34	0.0963	-0.3775	32.4
11	1	UMIAM STAGE 1	UMIAM STAGE 2	-6.675	-0.886	0.0013	-0.148	7.5
12	1	UMIAM STAGE 1	UMIAM	19.634	4.842	0.0196	-0.2077	22.6
13	1	UMIAM STAGE 1	UMIAM STAGE 3	-31.564	-0.142	0.1649	-0.4949	35.2
14	1	UMIAM STAGE 1	UMIAM STAGE 3	-31.564	-0.142	0.1649	-0.4949	35.2
15	1	UMIAM STAGE 3	UMIAM STAGE 4	-14.744	-0.144	0.0197	-0.4466	16.4
16	1	UMIAM STAGE 3	UMIAM STAGE 4	-17.815	-0.081	0.0238	-0.3518	19.8
17	1	UMIAM STAGE 3	UMTRU	-6.366	-0.859	0.0156	-2.0583	7.2
18	1	UMIAM STAGE 3	UMTRU	-6.366	-0.859	0.0156	-2.0583	7.2

Procurement of Web Based Protection Database Management Software and Protection Setting Calculation Tool for North Eastern Region

Sl.No	No. of cks	From Station	To Station	FORWARD		LOSS		% LOADING
				MW	MVA _r	MW	MVA _r	
19	1	UMIAM STAGE 4	UMTRU	-3.98	-0.551	0.0044	-1.5155	4.5
20	1	UMIAM STAGE 4	UMTRU	-3.98	-0.551	0.0044	-1.5155	4.5
21	1	UMIAM	NEHU	2.566	-0.364	0.0004	-0.3101	2.9
22	1	UMTRU	EPIP2	-3.19	1.301	0.0001	-0.0356	3.8
23	1	UMTRU	EPIP2	-3.19	1.301	0.0001	-0.0356	3.8
24	1	UMTRU	NEW UMTRU	-14.352	1.725	0.001	-0.0232	16
25	1	EPIP2	NEW UMTRU	-4.119	-0.077	0.0002	-0.0609	4.6
26	1	EPIP2	EPIP1	1.188	1.592	0.0001	-0.1545	2.3
27	1	EPIP2	EPIP1	1.188	1.592	0.0001	-0.1545	2.3
28	1	KILLING/BYRNIHAT	EPIP2	17.197	3.784	0.0297	-0.4568	19.6
29	1	KILLING/BYRNIHAT	EPIP2	17.197	3.784	0.0297	-0.4568	19.6
30	1	EPIP2	TRISHUL	LINE	IS	OPEN	0	0
31	1	EPIP2	NALARI	12.433	1.535	0.0002	-0.0057	13.9
32	1	EPIP1	GREYSTONE	0	-0.02	0	-0.0204	0
33	1	EPIP1	MEGCRBD	0	-0.015	0	-0.0153	0
34	1	EPIP1	KILLING/BYRNIHAT	-20.784	-5.523	0.0371	-0.3561	23.8
35	1	EPIP1	MAITHN	13.348	4.368	0.0008	-0.0205	15.5
36	1	EPIP1	SHYAMCEM	15.501	5.083	0.0007	-0.0136	18.1
37	1	EPIP1	SAIPRAKASH	0	-0.227	0	-0.2268	0.3
38	1	MAWLAI	NEHU	-29.705	0.534	0.0663	-0.2377	33.2
39	1	NEHU	NEIGRIHMS	-14.419	-1.509	0.0133	-0.3048	16.2
40	1	NEHU	MUSTEM	-18.45	-1.777	0.1352	-1.7974	20.6
41	1	MUSTEM	KHLIEHERIAT	-36.941	5.989	0.2055	-0.314	41.6
42	1	NEIGRIHMS	KHLIEHERIAT	-19.929	-0.221	0.2366	-2.627	22.4
43	1	KHLIEHERIAT	LUMSHNONG	4.609	3.507	0.0084	-1.1976	7.3
44	1	KHLIEHERIAT	MYNTDU LESKA	-10.146	-0.091	0.0253	-1.3027	11.3
45	1	KHLIEHERIAT	MYNTDU LESKA	-10.146	-0.091	0.0253	-1.3027	11.3
46	1	KHLIEHERIAT	KHLIEHERIAT	-33.099	-0.249	0.0547	-0.1473	36.5
47	1	KHLIEHERIAT	KHLIEHERIAT	-22.915	-0.277	0.0379	-0.3108	25.3
48	1	LUMSHNONG	MPL	-1.771	-3.948	0.0001	-0.0152	4.8
49	1	LUMSHNONG	GVIL	6.416	2	0.0009	-0.109	7.5
50	1	LUMSHNONG	CMCL	LINE	IS	OPEN	0	0
51	1	LUMSHNONG	MCL	0.431	-0.027	0	-0.1683	0.5
52	1	LUMSHNONG	ADHUNIK	1.102	-0.945	0.0001	-0.1834	1.6
53	1	LUMSHNONG	HILLCEMENT	6.353	1.812	0.0023	-0.2749	7.4
54	1	LUMSHNONG	JFUD	2.099	0.593	0.0001	-0.0967	2.4
55	1	EPIP1	KILLING/BYRNIHAT	-20.784	-5.523	0.0371	-0.3561	23.8
56	1	KILLING/BYRNIHAT	SAIPRAKASH	LINE	IS	OPEN	0	0

Procurement of Web Based Protection Database Management Software and Protection Setting Calculation Tool for North Eastern Region

Sl.No	No. of cks	From Station	To Station	FORWARD		LOSS		% LOADING
				MW	MVA _r	MW	MVA _r	
57	1	EPIP2	TRISHUL	LINE	IS	OPEN	0	0
58	1	LUMSHNONG	JFUD	2.099	0.593	0.0001	-0.0967	2.4
59	1	EPIP1	MEGCRBD	0	-0.015	0	-0.0153	0
60	1	KHLIEHERIAT	KHANDONG_GEN	-27.97	-0.294	0.2952	-1.4249	30.9
61	1	KHLIEHERIAT	KHANDONG_GEN	-26.917	-0.364	0.2841	-1.5346	29.7
62	1	EPIP1	ADHUNIK	LINE	IS	OPEN	0	0
63	1	EPIP2	MEGH_SOVAISPT	LINE	IS	OPEN	0	0
64	1	EPIP2	MEGH_SOVAISPT	LINE	IS	OPEN	0	0
65	1	UMIAM	RNB_CEMENT	LINE	IS	OPEN	0	0
66	1	MAWLAI	SOHRA	0	-2.104	0.0004	-2.1042	2.4
67	1	EPIP1	PIONEER CARBIDA	5.813	1.831	0.0006	-0.0804	6.8
68	1	NEHU	MYNTDU LESKA	-15.278	-1.675	0.234	-4.8082	17.4
Mizoram								
132 kV								
1	1	AIZWAL	LUANGMUAL	21.469	8.327	0.0044	-0.026	27
2	1	ZUNGTUI	SERCHIP	8.957	-5.863	0.0584	-2.2788	12.7
3	1	SERCHIP	LUNGLEI	8.526	-3.708	0.0459	-2.3531	11
4	1	ZUNGTUI	KHAWZWAL	3.074	-4.557	0.0173	-6.5764	6.5
5	1	SAITUAL	KHAWZWAL	3.192	-2.503	0.0057	-1.9084	4.8
6	1	BAIRABI	KOLASIB	18.291	0.295	0.0954	-1.2684	20.4
7	1	KOLASIB	MELRIAT	-6.987	-8.07	0.0008	-0.0329	12
8	1	KOLASIB	BADARPUR	-13.627	-3.261	0.1912	-4.9415	15.7
9	1	KOLASIB	AIZWAL	33.797	11.106	0.8265	-1.18	40
10	1	AIZWAL	MELRIAT	58.863	2.736	0.2418	0.2709	68.9
11	1	KHAWZWAL	CHAMPAI	2.367	0.023	0.0011	-0.8016	3
12	1	ZUNGTUI	SAITUAL	6.341	-3.511	0.0244	-2.1771	8.6
13	1	AIZWAL	TIPAIMUKH	-16.617	-11.768	0.3636	-3.6493	23.8
14	1	ZUNGTUI	MELRIAT	-54.85	-0.966	0.3259	0.3168	64.9
Nagaland								
132 kV								
1	1	MELURI	KIPHIRE	-5.398	2.136	0.0156	-2.0735	7.7
2	1	KOHIMA	MELURI	-1.051	-0.011	0.0032	-3.723	4.3
3	1	KOHIMA	WOKHA	-12.201	-1.942	0.0813	-2.7591	13.7
4	1	MOKOKCHUNG PG	MOKOKCHUNG	15.01	7.128	0.0035	-0.0649	18.2
5	1	MOKOKCHUNG PG	MOKOKCHUNG	15.01	7.128	0.0035	-0.0649	18.2
6	1	MOKOKCHUNG	WOKHA	-0.597	5.445	0.0107	-1.5375	7.7
7	1	WOKHA	SANIS	19.135	0.183	0.0214	-0.2807	21
8	1	WOKHA	DIMAPUR	9.567	-1.087	0.0789	-4.5618	11.2

Procurement of Web Based Protection Database Management Software and Protection Setting Calculation Tool for North Eastern Region

Sl.No	No. of cks	From Station	To Station	FORWARD		LOSS		% LOADING
				MW	MVA _r	MW	MVA _r	
9	1	WOKHA	DIMAPUR	9.567	-1.087	0.0789	-4.5618	11.2
10	1	DIMAPUR	DIMPUR PH	26.307	9.929	0.0037	-0.0166	31.2
11	1	DIMAPUR	DIMPUR PH	26.307	9.929	0.0037	-0.0166	31.2
12	1	SANIS	WOKHA	17.906	0.056	0.0786	-1.1886	19.7
13	1	DIMAPUR	KOHIMA	9.481	-2.407	0.0385	-2.1884	10.9
14	1	KOHIMA	KARONG	LINE	IS	OPEN	0	0
66 kV								
15	1	MON	TIZIT	-2.208	3.729	0.0426	-0.2592	18.2
16	1	KIPHIRE	LIKJIMRO_GEN	-7.829	0.201	0.1355	-0.2212	29.3
17	1	KIPHIRE	LIKJIMRO_GEN	-7.829	0.201	0.1355	-0.2212	29.3
18	1	NAGINIMORA	TIZIT	4.548	-3.48	0.0965	-0.3058	22.9
19	1	NAGINIMORA	TULI	-7.3	2.432	0.1433	-0.1291	31.2
20	1	MOKOKCHUNG	TULI	17.272	1.732	1.0263	0.9907	64.2
21	1	MOKOKCHUNG	TUENSANG	LINE	IS	OPEN	0	0
22	1	MOKOKCHUNG	ZUNHEBOTO	6.289	2.18	0.1173	-0.319	25.3
23	1	DAIRY FARM	NITOFARM	2.281	0.703	0.0041	-0.1304	9.1
24	1	POWER HOUSE	DAIRY FARM	4.83	1.599	0.0078	-0.0457	19.1
25	1	DIMPUR PH	POWER HOUSE	14.353	5.165	0.0383	0.0286	56.7
26	1	KIPHIRE	TUENSANG	6.564	2.253	0.171	-0.3737	25.9
27	1	CHUMUKIDIMA	SINGRIJAN Tower	-7.151	-2.652	0.0287	-0.0491	28.5
28	1	GANESHNAGAR	SINGRIJAN Tower	-5.113	-1.931	0.0394	-0.1895	20.6
29	1	DIMPUR PH	SINGRIJAN Tower	6.18	2.13	0.0141	-0.0421	24.4
30	1	DIMPUR PH	SINGRIJAN Tower	6.18	2.13	0.0141	-0.0421	24.4
Tripura								
132 kV								
1	1	PALATANA	SURAJMANINAGAR	114.887	4.513	0.4494	4.9189	6.6
2	1	SURAJMANINAGAR	COMILLA_NORTH	58.743	8.863	0.2931	0.5329	6.5
3	1	SURAJMANINAGAR	COMILLA_NORTH	58.743	8.863	0.2931	0.5329	6.5
4	1	DHARMNAGAR	DULABCHHERA	2.032	-8.138	0.0151	-1.2536	9.4
5	1	DHARMNAGAR	PKBARI	-17.56	-0.936	0.1082	-1.557	19.8
6	1	PKBARI	KAILASAHAR	8.365	2.105	0.0131	-0.8671	9.9
7	1	KUMARGHAT	BADARPUR	5.05	-9.069	0.0706	-5.8273	11.6
8	1	PKBARI	KUMARGHAT	-44.551	8.521	0.0195	-0.0035	50.7
9	1	KUMARGHAT	AGTPP	-81.668	0.75	0.4936	0.7822	91.3
10	1	DHALABIL	KAMALPUR TSECL	5.037	-2.706	0.0089	-1.57	6.4
11	1	DHALABIL	AGARTALA	-12.549	-0.005	0.0682	-2.0852	14.3
12	1	KAMALPUR TSECL	PKBARI	-1.532	-4.538	0.0049	-1.5343	5.4
13	1	KAMALPUR TSECL	AMBASSA	1.754	1.718	0.0027	-1.5311	4.1

Procurement of Web Based Protection Database Management Software and Protection Setting Calculation Tool for North Eastern Region

Sl.No	No. of cks	From Station	To Station	FORWARD		LOSS		% LOADING
				MW	MVA _r	MW	MVA _r	
14	1	AGARTALA	SURAJMANINAGAR	8.246	7.083	0.0213	-0.8483	12.8
15	1	AGARTALA	SURAJMANINAGAR	8.246	7.083	0.0213	-0.8483	12.8
16	1	AMBASSA	PKBARI	-2.261	-5.412	0.0102	-2.2148	6.6
17	1	AMBASSA	TELIAMURA	-0.392	7.131	0.0144	-1.1975	9.4
18	1	TELIAMURA	BARAMUR	-10.472	3.643	0.017	-0.6465	12.8
19	1	BARAMUR	JIRANI	-11.106	-3.374	0.0162	-0.5812	13.1
20	1	JIRANI	BODHJANGNAGR	-22.329	-7.016	0.0706	-0.5007	26.4
21	1	BODHJANGNAGR	SURAJMANINAGAR	-1.547	1.992	0.0015	-0.907	3.7
22	1	BODHJANGNAGR	SURAJMANINAGAR	-1.547	1.992	0.0015	-0.907	3.7
23	1	AGARTALA	BODHJANGNAGR	22.124	11.143	0.0468	-0.2884	27.9
24	1	AGARTALA	AGTPP	0.273	-25.867	0.0523	-0.2988	28.9
25	1	AGARTALA	AGTPP	0.273	-25.867	0.0523	-0.2988	28.9
26	1	AGARTALA	ROKHIA	-44.821	12.304	0.7231	-0.0436	52.4
27	1	AGARTALA	ROKHIA	-44.821	12.304	0.7231	-0.0436	52.4
28	1	UDAIPUR	MONARCHAK	-14.28	-4.162	0.0844	-1.8873	16.7
29	1	ROKHIA	MONARCHAK	-44.975	18.075	0.6456	0.0658	54.4
30	1	MONARCHAK	RABINDRANAGR	13.8	5.616	0.0063	-0.1373	16.6
31	1	MONARCHAK	RABINDRANAGR	13.8	5.616	0.0063	-0.1373	16.6
32	1	PALATANA	UDAIPUR	16.076	6.583	0.0321	-0.4793	19.6
66 kV								
33	1	AGARTALA	BARAMUR	-16.224	-5.887	0.5439	0.6028	70.1
34	1	BADHARGHAT	AGARTALA	-16.115	-5.762	0.1094	0.1244	70.5
35	1	BARAMUR	TELIAMURA	4.626	0.918	0.018	-0.1017	18.5
36	1	TELIAMURA	OMPI	6.074	1.891	0.0469	-0.1072	24.9
37	1	OMPI	AMARPUR	3.522	1.082	0.0171	-0.1618	14.8
38	1	AMARPUR	GUMTI	LINE	IS	OPEN	0	0
39	1	GUMTI	JATANBR	-1.502	-0.539	0.0018	-0.1187	6.2
40	1	JATANBR	UDAIPUR	-7.419	-2.651	0.1369	-0.1688	30
41	1	UDAIPUR	BISHRAMGUNJ	2.512	0.755	0.007	-0.174	10.1
42	1	BISHRAMGUNJ	GAKULNAGAR	LINE	IS	OPEN	0	0
43	1	UDAIPUR	BAGAFA	11.288	3.702	0.2228	0.0703	44.8
44	1	BAGAFA	SATCHAND	5.056	1.476	0.0409	-0.1749	20.7
45	1	BAGAFA	BELONIA	LINE	IS	OPEN	0	0
46	1	SATCHAND	SABROOM	2.51	0.737	0.0071	-0.1499	10.5
47	1	BELONIA	RABINDRANAGR	-13.039	-5.04	0.5539	0.4463	55.7
48	1	RABINDRANAGR	ROKHIA	-5.04	-2.901	0.0474	-0.1861	22.1
49	1	ROKHIA	BADHARGHAT	LINE	IS	OPEN	0	0
50	1	BADHARGHAT	GAKULNAGAR	3.771	1.262	0.0143	-0.0938	16.5

Sl.No	No. of cks	From Station	To Station	FORWARD		LOSS		% LOADING
				MW	MVAr	MW	MVAr	
51	1	KUMARGHAT	AIZWAL	32.048	-0.454	1.3054	-3.2544	35.8
52	1	BOXNAGAR	ROKHIA	-2.906	-1.068	0.0021	-0.0377	11.6

Geographical Diagram of Existing Arunachal Pradesh Network (DEC-18)

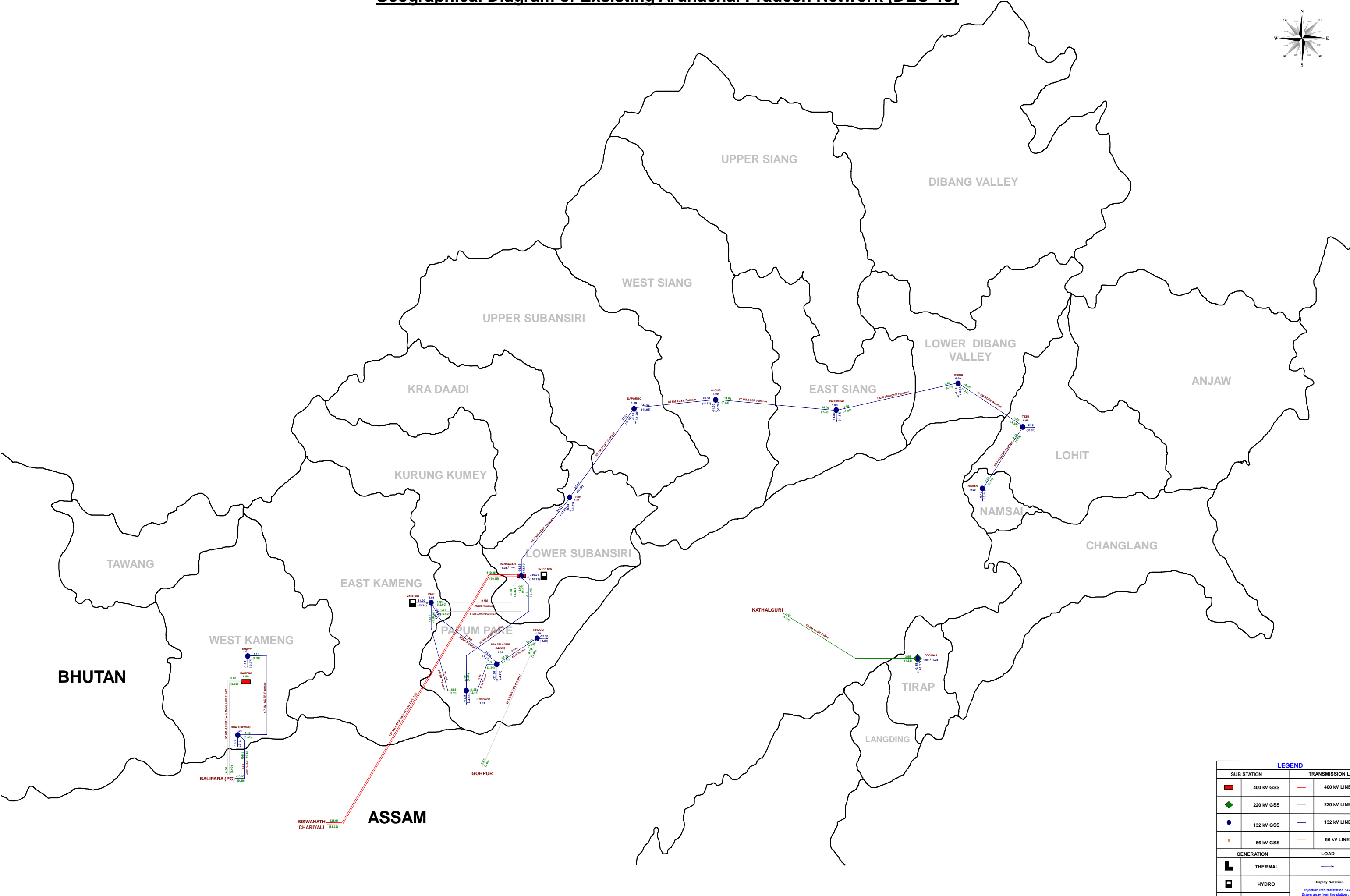
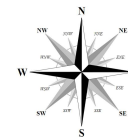

LEGEND	
SUB STATION	TRANSMISSION LINE
400 kV GSS	400 kV LINE
220 kV GSS	220 kV LINE
132 kV GSS	132 kV LINE
66 kV GSS	66 kV LINE
GENERATION	LOAD
THERMAL	Injection into the station - +ve Drawn away from the station - -ve Voltage Map in PU Flows in MW and (MW/s)
HYDRO	
GAS	

Geographical Diagram of Existing Assam Network (DEC-18)

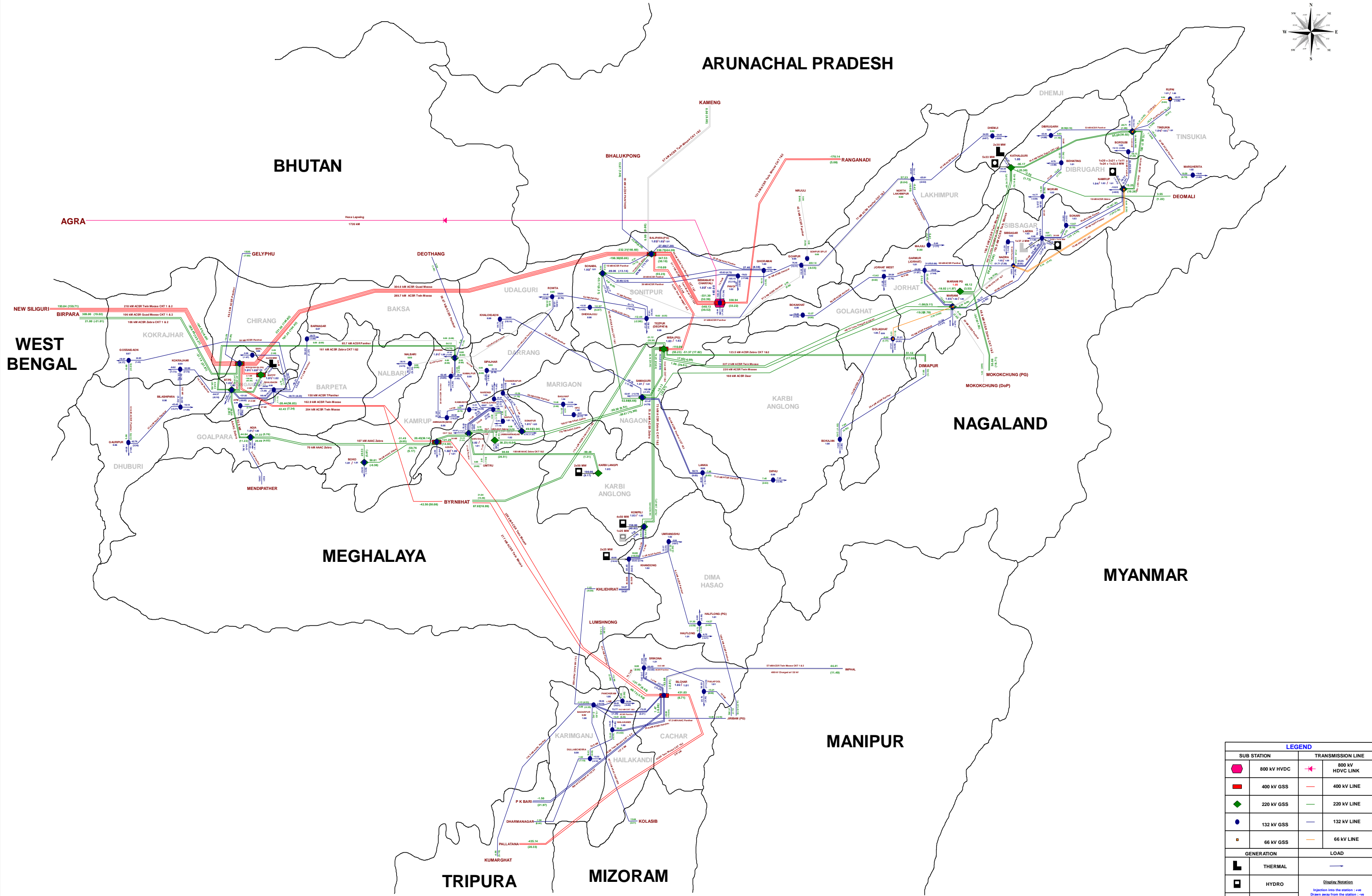
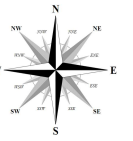

LEGEND	
SUB STATION	TRANSMISSION LINE
	800 kV HVDC
	400 kV GSS
	220 kV GSS
	132 kV GSS
	66 kV GSS
	800 kV HVDC LINK
	400 kV LINE
	220 kV LINE
	132 kV LINE
	66 kV LINE
GENERATION	
	THERMAL
	HYDRO
	GAS
LOAD	
	Injection into the station - +ve Drawn away from the station - -ve Voltage Mag in PU Flows in MW and (MW/s)

Geographical Diagram of Existing Manipur Network (DEC-18)

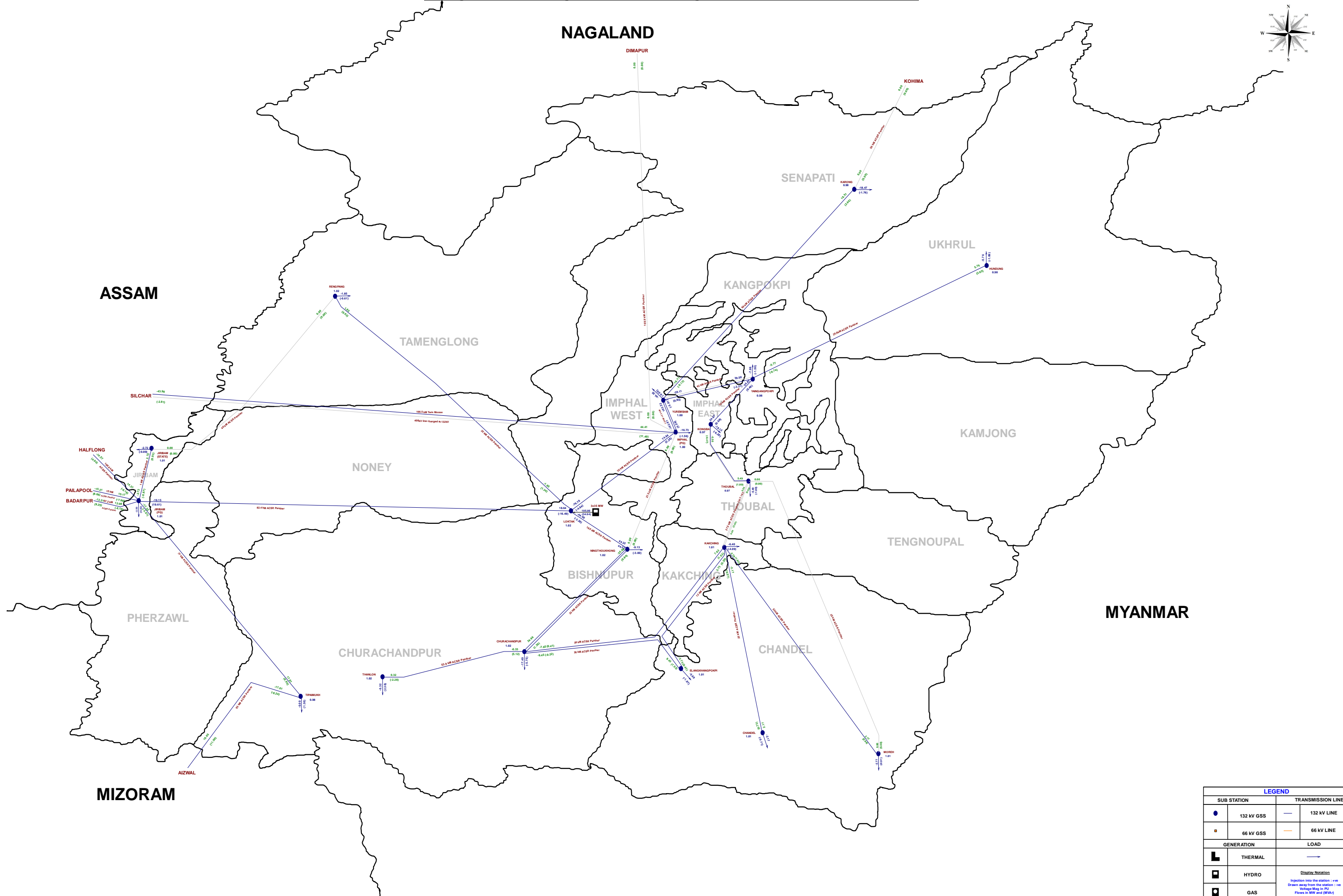
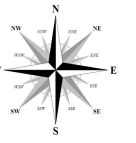

LEGEND	
	132 kV GSS
	66 kV GSS
	THERMAL
	HYDRO
	GAS
	132 kV LINE
	66 kV LINE
	GENERATION
	LOAD
Injection into the station - +ve Drawn away from the station - -ve Voltage Mag in PU Flows in MW and (MW/s)	

Drawn By	Checked By	Approved By	Rev. No.	Date	Remarks

	Geographical Power Map/North Eastern Region/Dec - 18/Manipur	Manipur State Existing Network (Dec-18) Geographical Map	NERPC/SE/PDMS/2018/4135 Dated: 31st July, 2018	North Eastern Regional Power Committee NERPC Complex, Dong Parmaw, Lapalang, Shillong - 793006, Meghalaya	Power Research and Development Consultant Pvt. Ltd. Plot No. 119, Cross, 2nd Stage, West of Chara Road, Manipal, 781 006, Lule, Pin - 781 006-0240 5055 E-mail: prdc@rcvt.com
	Drawn In	DRW. No.	Drawing Detail		

Geographical Diagram of Existing Meghalaya Network (DEC-18)

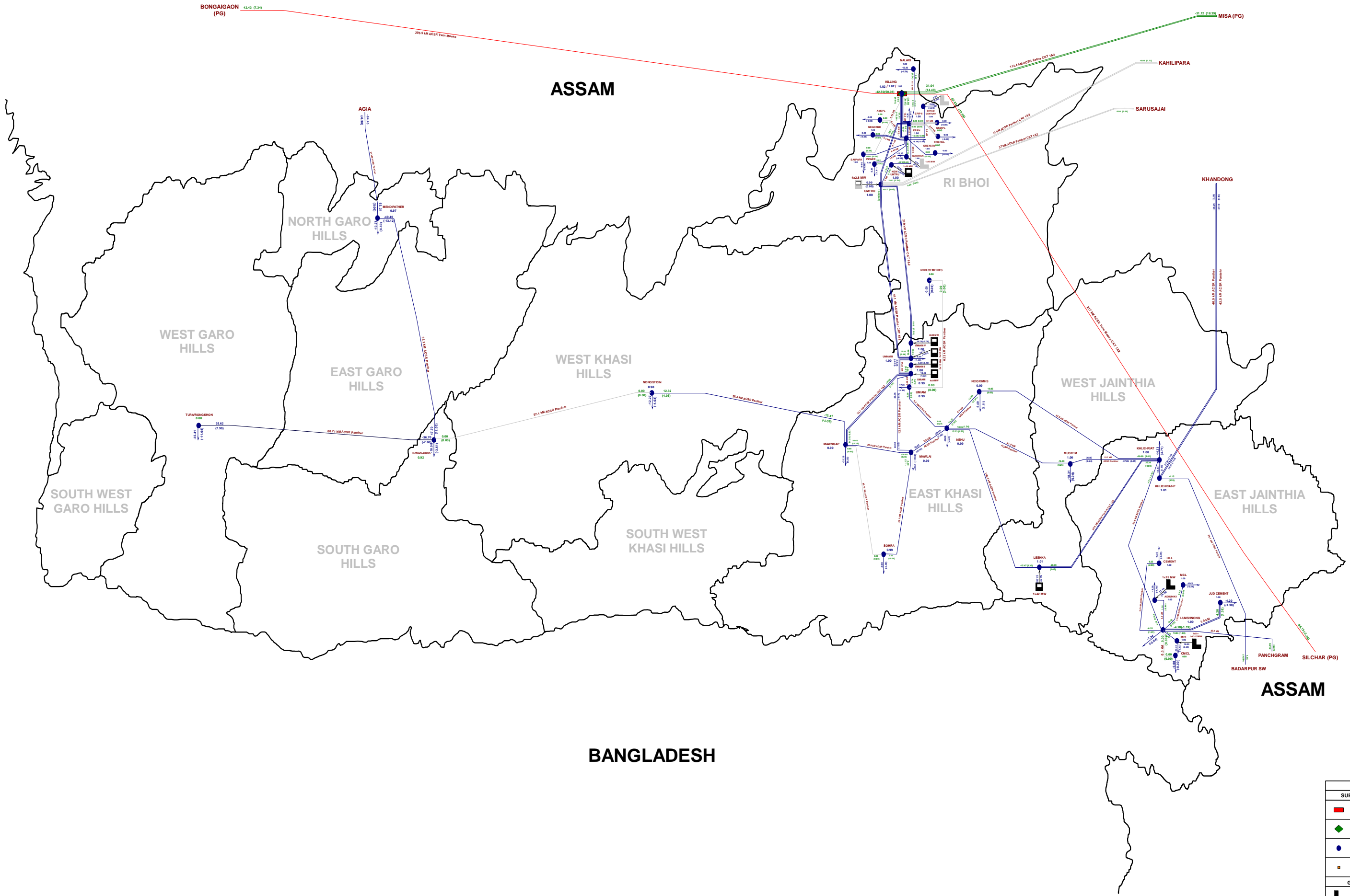
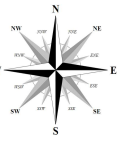

LEGEND	
SUB STATION	TRANSMISSION LINE
400 kV GSS	400 kV LINE
220 kV GSS	220 kV LINE
132 kV GSS	132 kV LINE
66 kV GSS	66 kV LINE
GENERATION	LOAD
THERMAL	Display Notation
HYDRO	Injection into the station - +ve
GAS	Drawn away from the station - -ve
	Voltage Mag in PU
	Flows in MW and (MW/s)

Geographical Diagram of Existing Mizoram Network (DEC-18)

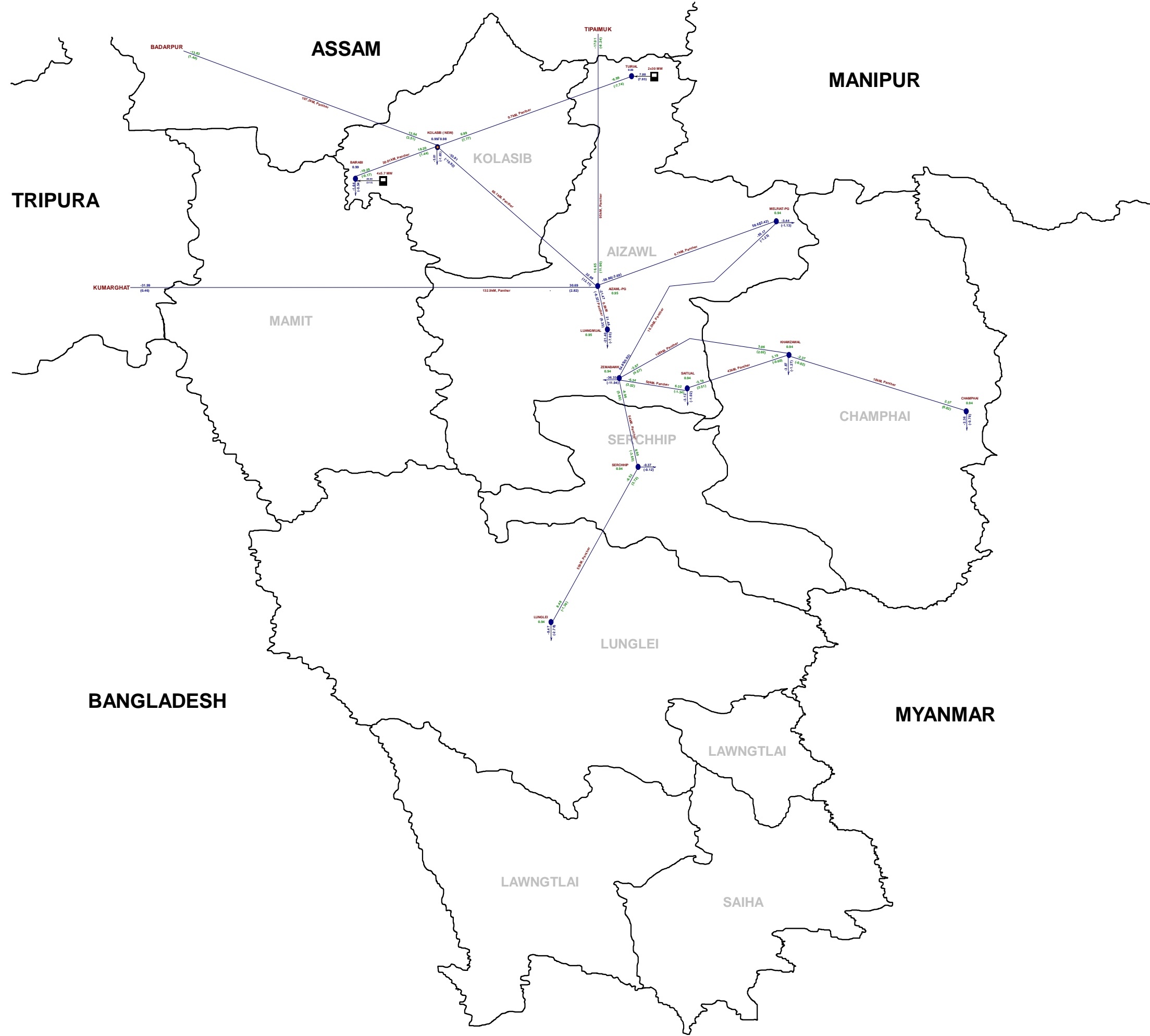
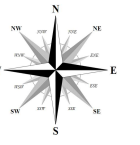

LEGEND	
SUB STATION	TRANSMISSION LINE
● 132 kV GSS	— 132 kV LINE
■ 66 kV GSS	— 66 kV LINE
GENERATION	LOAD
⊞ THERMAL	⊞
⊞ HYDRO	⊞
⊞ GAS	⊞
Display Notation Injection into the station +ve Drains away from the station -ve Voltage Mag in PU Flows in MW and (MW/s)	

Geographical Diagram of Existing Nagaland Network (DEC-18)

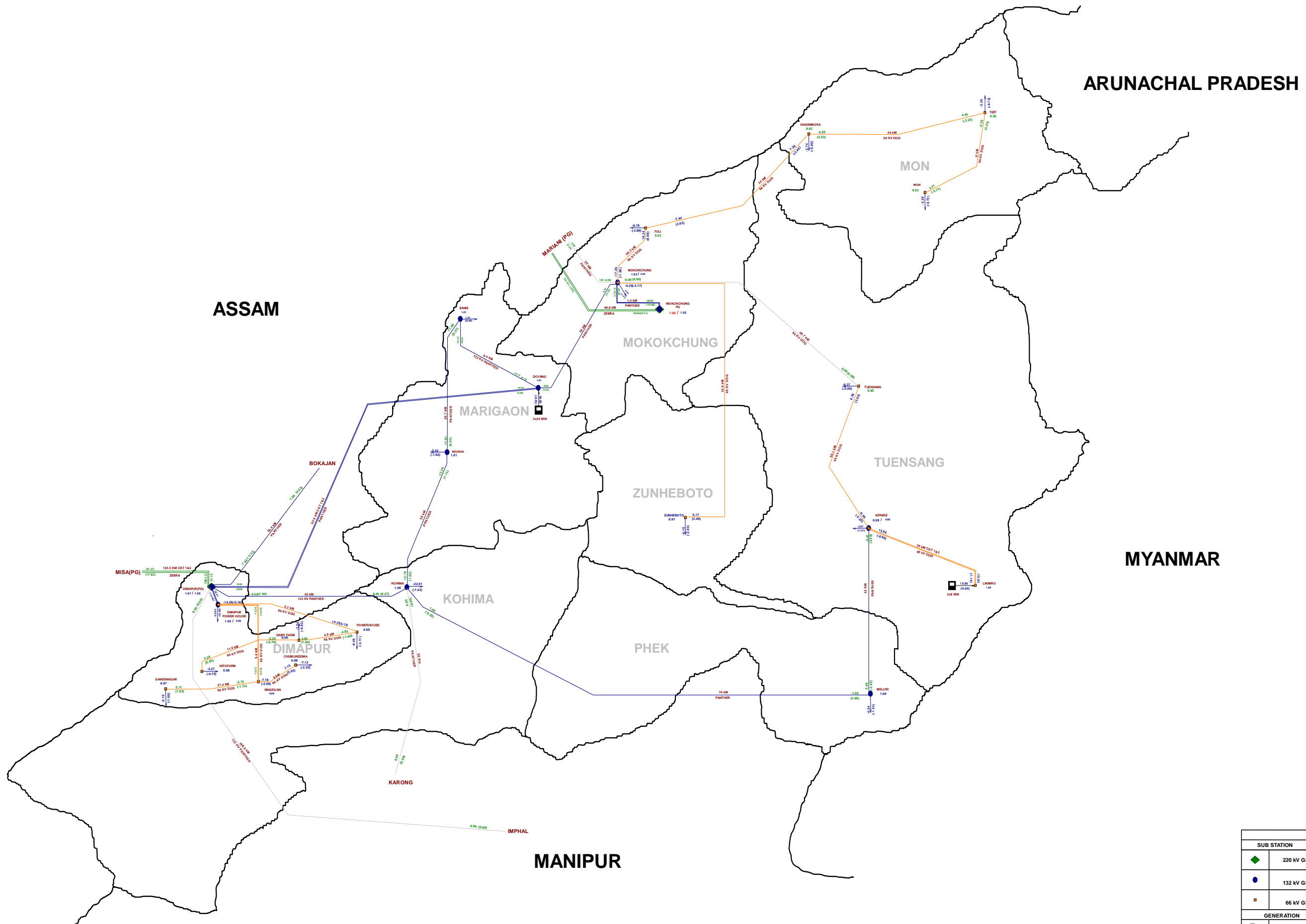
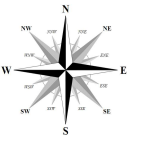

LEGEND	
	220 kV GSS
	132 kV GSS
	66 kV GSS
	GENERATION
	THERMAL
	HYDRO
	GAS
	220 kV LINE
	132 kV LINE
	66 kV LINE
	LOAD
	Injection into the station +ve Drawn away from the station -ve Voltage Mag in PU Flows in MW and (MWs)

Geographical Diagram of Existing Tripura Network (DEC-18)

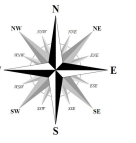

BANGLADESH

ASSAM

UNAKOTI

NORTH TRIPURA

WEST TRIPURA

KHOWAI

DHALAI

MIZORAM

SEPAHIJALA

GOMATI

BANGLADESH

SOUTH TRIPURA

BANGLADESH

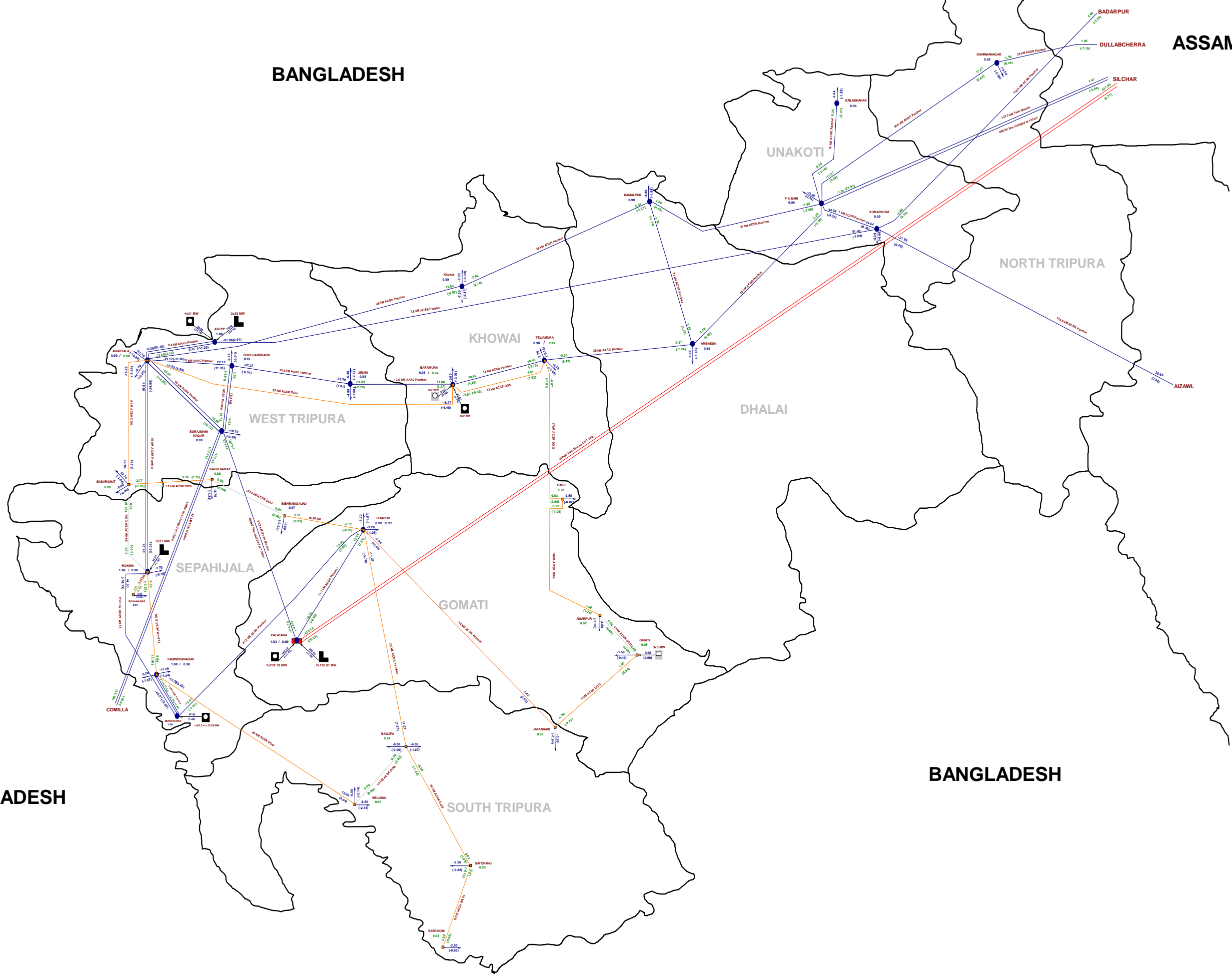

LEGEND	
	400 kV GSS
	132 kV GSS
	66 kV GSS
	THERMAL
	HYDRO
	GAS
	400 kV LINE
	132 kV LINE
	66 kV LINE
	GENERATION
	LOAD
	Injection into the station +ve
	Drawn away from the station -ve
	Display Notation
	Voltage Mag in PU
	Flow in MW and (MW%)

Drawn By	Checked By	Approved By	Rev. No.	Date	Remarks



Geographical Power Map North Eastern Region Dec - 18 Tripura	Tripura State Existing Network (Dec-18) Geographical Map

NERPC/SE/PDMS/2018/4135	North Eastern Regional Power Committee
Dated: 31st July, 2018	NERPC Complex, Dong Parmaw, Lapalang, Shillong - 793006, Meghalaya

	Client
--	--------

Power Research and Development Consultant Pvt. Ltd.
 Pl. 11th Cross, 2nd Stage,
 West of Chhatra Road,
 Bangalore - 560 086, India
 Ph: 08-68424250
 Email: prdc@prdc.com

SINGLE LINE DIAGRAM OF NORTH EASTERN REGION (DEC-2018)

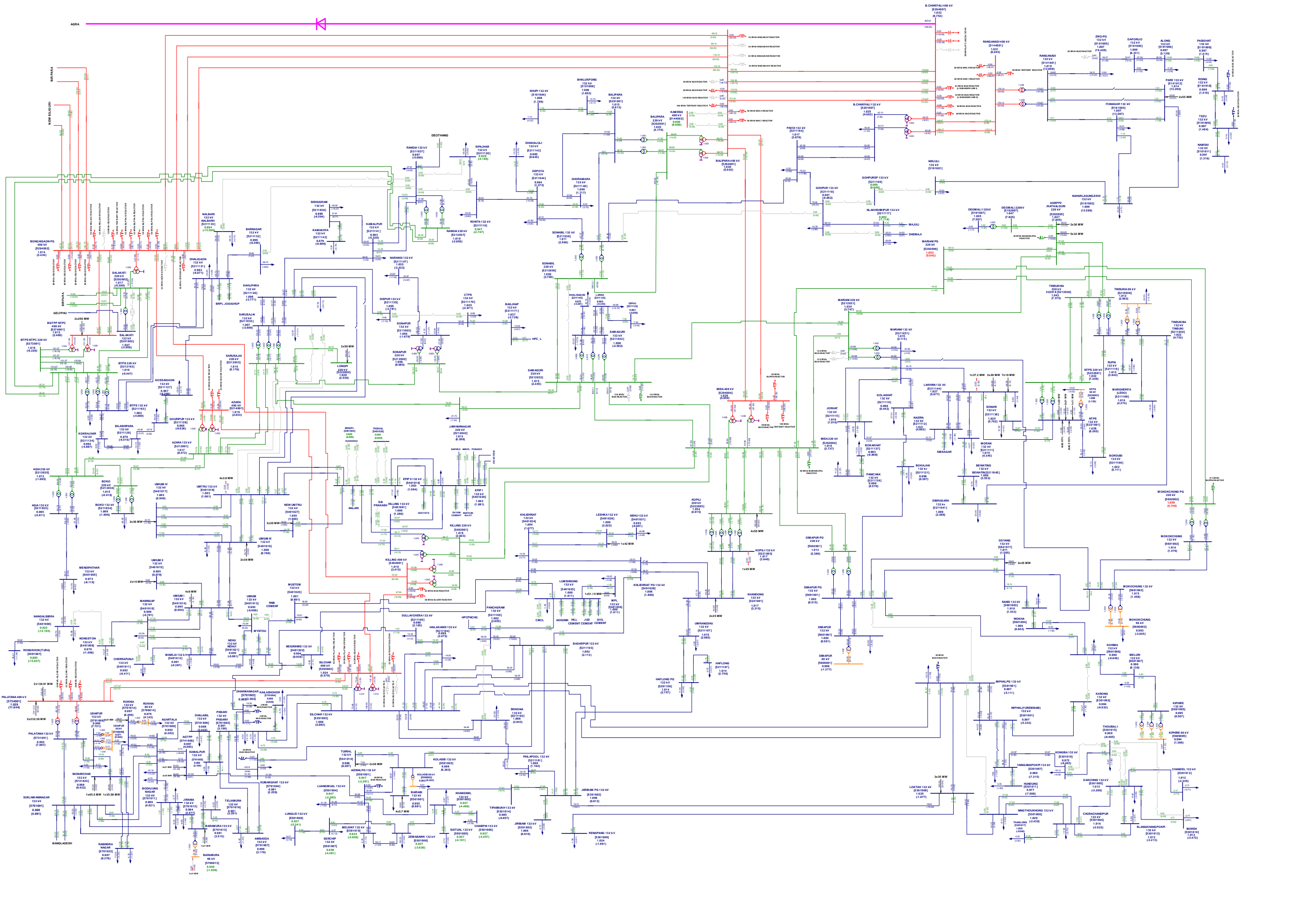

SLD Notation	
—	800 kV HVDC Bus
—	400 kV Bus
—	220 kV Bus
—	132 kV Bus
—	66 kV Bus
	2 Winding Transformer
	800 kV HVDC Link
	400 kV Line
	220 kV Line
	132 kV Line
	66 kV Line
	Generation
	Load
	Shunt Capacitor
	Shunt Reactor

ANNEXURE-III SHORT CIRCUIT STUDY RESULTS

Table H: State wise 3-Ph and SLG fault results of North Eastern Region grid

Substation Name	Rated Voltage (in kV)	3Ph to ground fault		SLG fault	
		Fault MVA	Fault Current (in kA)	Fault MVA	Fault Current (in kA)
Arunachal Pradesh					
Ranganadi	400	4447.118	6.419	4654.827	6.719
	132	4051.038	17.719	3666.719	16.038
Pare	132	948.348	4.148	895.807	3.918
Deomali	220	1819.799	4.776	1565.947	4.11
	132	555.881	2.431	529.734	2.317
Nirjuli	132	794.396	3.475	561.592	2.456
Tezu	132	87.404	0.382	44.257	0.194
Roing	132	103.236	0.452	52.357	0.229
Ziro	132	766.313	3.352	417.214	1.825
Naharlagun(Lekhi)	132	969.155	4.239	753.835	3.297
Itanagar	132	1196.124	5.232	903.222	3.951
Khuppi	132	311.545	1.363	167.576	0.733
Daporijo	132	294.594	1.289	152.379	0.666
Along	132	186.389	0.815	95.335	0.417
Bhalukpong	132	624.022	2.729	362.302	1.585
Passighat	132	138.586	0.606	70.538	0.309
Namsai	132	72.862	0.319	36.839	0.161
Assam					
Biswanath Chariyali	400	6068.058	8.758	3726.437	5.379
	132	2412.012	10.55	2134.847	9.338
Azara (Kukurmara)	400	4553.762	6.573	2105.013	3.038
	220	4030.27	10.577	3662.127	9.611
	132	667.638	2.92	656.669	2.872
Sonapur	220	2061.073	5.409	1696.769	4.453
	132	902.002	3.945	1013.69	4.434
Balipara PG	400	6797.03	9.811	3753.519	5.418
	220	3749.668	9.84	3254.962	8.542
	132	1873.842	8.196	1631.018	7.134
Silchar PG	400	5170.228	7.463	2757.387	3.98
	132	3937.277	17.221	3596.141	15.729
Misa PG	400	5256.627	7.587	2378.286	3.433
	220	5747.23	15.083	5085.656	13.346
Bongaigaon PG	400	10396.48	15.006	8247.167	11.904
	220	5437.236	14.269	4632.608	12.157
	132	372.594	1.63	368.214	1.611
Bongaigaon (BTPS) (ASEB)	220	5505.748	14.449	4725.092	12.4
	132	2086.679	9.127	1963.754	8.589

Procurement of Web Based Protection Database Management Software and Protection Setting Calculation Tool for North Eastern Region

Substation Name	Rated Voltage (in kV)	3Ph to ground fault		SLG fault	
		Fault MVA	Fault Current (in kA)	Fault MVA	Fault Current (in kA)
Tinsukia	220	2267.148	5.95	2153.644	5.652
	132	1431.771	6.262	1253.495	5.483
Mariani	220	2101.428	5.515	1374.563	3.607
	132	1604.258	7.017	1122.984	4.912
Samaguri	220	4514.898	11.849	3414.662	8.961
	132	1182.024	5.17	1090.286	4.769
Sarusajai	220	3715.848	9.752	3086.621	8.1
	132	1750.404	7.656	1559.297	6.82
Boko	220	2390.033	6.272	1647.009	4.322
	132	799.645	3.498	694.928	3.04
Agia	220	3170.932	8.322	2206.043	5.789
	132	871.091	3.81	777.857	3.402
Sonabil	220	3424.948	8.988	2735.693	7.179
	132	2014.723	8.812	1707.413	7.468
Rangia	220	1526.895	4.007	985.462	2.586
	132	1215.547	5.317	843.272	3.688
Amingaon (New) / Sishugram	132	772.533	3.379	462.194	2.022
Jawaharnagar	220	3052.958	8.012	2277.362	5.977
Dibrugarh	132	778.48	3.405	466.695	2.041
Pailapool	132	1556.879	6.81	915.224	4.003
Deopata (Tezpur)	132	1295.976	5.668	875.378	3.829
Dhemaji	132	197.08	0.862	102.014	0.446
Srikona	132	3757.82	16.436	3290.901	14.394
Panchgram	132	3120.593	13.649	2167.824	9.482
Hailakandi	132	1760.385	7.7	1073.259	4.694
Dullabcherra	132	1121.924	4.907	625.888	2.738
Umranshu	132	1606.632	7.027	1061.91	4.645
Margherita	132	821.043	3.591	542.054	2.371
Rupai (Doomdooma)	132	636.878	2.786	413.79	1.81
Moran	132	888.709	3.887	539.117	2.358
Nazira	132	1415.915	6.193	1016.325	4.445
Sibsagar	132	984.741	4.307	623.053	2.725
Majauli	132	215.446	0.942	111.849	0.489
Jorhat (Garmur)	132	1315.039	5.752	845.764	3.699
Golaghat	132	1057.793	4.627	639.863	2.799
North Lakhimpur	132	280.871	1.228	147.368	0.645
Gohpur	132	584.252	2.555	322.683	1.411
Rowta	132	434.323	1.9	237.87	1.04
Sipajhar	132	296.872	1.298	157.982	0.691
Bokajan	132	1087.483	4.757	669.879	2.93

Substation Name	Rated Voltage (in kV)	3Ph to ground fault		SLG fault	
		Fault MVA	Fault Current (in kA)	Fault MVA	Fault Current (in kA)
Diphu	132	307.268	1.344	173.489	0.759
Lanka (Sankardev Nagar)	132	646.729	2.829	427.292	1.869
Narengi	132	549.422	2.403	411.266	1.799
Kahilipara	132	1703.778	7.452	1467.983	6.421
Gosaigaon	132	618.701	2.706	356.879	1.561
Gauripur	132	626.071	2.738	361.793	1.582
Bilashipara	132	865.274	3.785	532.113	2.327
APM Jogighopa	132	627.28	2.744	362.601	1.586
Dhaligaon	132	1398.654	6.118	1009.447	4.415
Bornagar	132	589.258	2.577	337.428	1.476
Nalbari	132	232.278	1.016	122.436	0.536
Kokrajhar	132	1417.448	6.2	1029.444	4.503
Jorhat West (Panichakua)	132	547.599	2.395	301.651	1.319
Bokakhat	132	252.335	1.104	131.992	0.577
Sonari	132	1281.884	5.607	856.304	3.745
Dispur	132	1523.335	6.663	1215.224	5.315
Ghoramari	132	1155.887	5.056	757.947	3.315
Kamalpur	132	1219.156	5.332	827.01	3.617
Dhekiajuli	132	541.515	2.369	303.543	1.328
Kamakhya	132	712.181	3.115	419.553	1.835
Khaloigaon	132	546.187	2.389	343.254	1.501
Bagjhap	132	422.667	1.849	283.255	1.239
Pavoi	132	2018.099	8.827	1511.851	6.613
Chandrapur (CTPS)	132	692.746	3.03	599.133	2.621
Haflong	132	1307.649	5.719	799.535	3.497
Behiating	132	761.358	3.33	451.397	1.974
Badarpur s/w station	132	3251.805	14.223	2292.535	10.027
Haflong (PG)	132	1349.878	5.904	831.335	3.636
Bordubi	132	1325.396	5.797	967.527	4.232
Manipur					
Imphal (Yurembam)	132	702.33	3.072	546.526	2.39
KARONG	132	350.605	1.533	212.874	0.931
JIRIBAM State	132	1607.445	7.031	956.247	4.182
Churachandpur	132	624.212	2.73	535.292	2.341
Kakching	132	486.591	2.128	412.72	1.805
Ningthoukhong	132	752.461	3.291	688.341	3.011
Yaingangpokpi	132	412.885	1.806	340.088	1.487
Rengpang	132	523.054	2.288	371.374	1.624
Kongba	132	311.407	1.362	299.893	1.312
Hundung	132	326.499	1.428	236.81	1.036

Procurement of Web Based Protection Database Management Software and Protection Setting Calculation Tool for North Eastern Region

Substation Name	Rated Voltage (in kV)	3Ph to ground fault		SLG fault	
		Fault MVA	Fault Current (in kA)	Fault MVA	Fault Current (in kA)
Chandel	132	376.907	1.649	276.296	1.208
Elangkhangpokpi	132	497.548	2.176	406.193	1.777
Tipaimukh	132	635.438	2.779	341.494	1.494
Thoubal	132	254.445	1.113	300.664	1.315
Moreh	132	296.544	1.297	322.769	1.412
Thanlon	132	345.981	1.513	224.871	0.984
Loktak	132	924.929	4.046	978.229	4.279
Imphal (PG)	132	713.045	3.119	556.09	2.432
Jiribam (PG)	132	1671.747	7.312	1002.105	4.383
Meghalaya					
Byrnihat (Killing)	400	4376.776	6.317	1960.781	2.83
	220	3822.292	10.031	3709.042	9.734
	132	2375.843	10.392	2559.002	11.193
Mendipather	132	535.005	2.34	363.102	1.588
Rongkhon (Tura)	132	197.446	0.864	109.205	0.478
Nangalbibra	132	292.432	1.279	170.386	0.745
Nongstoin	132	484.943	2.121	268.191	1.173
Mawngap (Mawphlang)	132	1404.875	6.145	967.514	4.232
Sohra (Cherrapunjee)	132	633.301	2.77	358.734	1.569
Mawlai	132	1753.113	7.668	1294.135	5.66
Umiam	132	1873.273	8.193	1443.126	6.312
Umiam Stg I	132	2028.244	8.871	1738.363	7.603
Umiam Stg II	132	1783.889	7.802	1452.307	6.352
Umiam Stg III	132	2221.706	9.717	2078.85	9.093
Umiam Stg IV	132	2112.85	9.241	1948.309	8.522
Umtru	132	2333.386	10.206	2304.691	10.08
EPIP II (Norbong)	132	2337.166	10.222	2322.211	10.157
EPIP I (Norbong/Rajabagan)	132	2270.577	9.931	2214.672	9.687
Nehu	132	1930.047	8.442	1431.872	6.263
NEIGRIHMS	132	1628.862	7.124	1096.934	4.798
Mustem (Jowai)	132	1622.412	7.096	1011.016	4.422
Khliehriat(S)	132	2547.416	11.142	1862.388	8.146
Lumshnong	132	2510.852	10.982	2305.748	10.085
Myntdu Leshka	132	1625.345	7.109	1265.433	5.535
New Umtru	132	2302.915	10.073	2256.187	9.868
Khliehriat_PG	132	2485.909	10.873	1753.869	7.671
Mizoram					
Bairabi	132	641.859	2.807	468.871	2.051
Khawzawl	132	328.361	1.436	175.218	0.766
Kolasib (Bawklang)	132	953.836	4.172	855.776	3.743

Substation Name	Rated Voltage (in kV)	3Ph to ground fault		SLG fault	
		Fault MVA	Fault Current (in kA)	Fault MVA	Fault Current (in kA)
	66	169.284	1.481	165.725	1.45
Luangmual	132	776.84	3.398	454.199	1.987
Saitual	132	380.905	1.666	205.344	0.898
Zungtui(Zemabawk)	132	597.508	2.613	336.421	1.471
Bukpui (Serchip)	132	336.626	1.472	179.916	0.787
Khawiva(Lunglei)	132	232.976	1.019	122.072	0.534
Keifangtlang(Champai)	132	287.527	1.258	152.227	0.666
Turial	132	946.864	4.141	858.447	3.755
Aizal PGCIL	132	788.594	3.449	462.239	2.022
Melriat PG	132	699.884	3.061	402.556	1.761
Nagaland					
DIMAPUR PG	220	1853.811	4.865	1259.901	3.306
	132	1425.781	6.236	1056.919	4.623
Mokokchung PG	220	1175.262	3.084	778.037	2.042
	132	811.113	3.548	614.198	2.686
Doyang	132	1067.355	4.668	992.651	4.342
Singrijan	66	539.912	4.723	432.257	3.781
Dimapur Power house(DoP Nag)	132	1413.977	6.185	1043.822	4.566
	66	633.182	5.539	546.481	4.78
Mokokchung/ Aolichen MKG	132	814.084	3.561	616.432	2.696
	66	268.825	2.352	243.044	2.126
Sanis	132	963.296	4.213	803.104	3.513
WOKHA	132	747.011	3.267	508.98	2.226
Kiphire	132	288.08	1.26	212.874	0.931
	66	203.903	1.784	178.985	1.566
Kohima State	132	772.818	3.38	503.07	2.2
Meluri	132	363.512	1.59	244.089	1.068
MON	66	46.109	0.403	28.79	0.252
Nagimora	66	74.488	0.652	48.146	0.421
Tizit	66	54.741	0.479	34.53	0.302
Tuli	66	103.074	0.902	69.202	0.605
Chumukidima	66	371.304	3.248	264.785	2.316
Dairy Farm	66	423.112	3.701	311.859	2.728
Ganeshnagar	66	241.328	2.111	159.811	1.398
Nitofarm	66	276.99	2.423	186.973	1.636
Powerhouse, Burma camp	66	539.912	4.723	432.257	3.781
Tuengsang	66	91.5	0.8	62.684	0.548
Zunheboto	66	121.454	1.062	83.705	0.732
Likjimro	66	175.992	1.54	191.258	1.673
Tripura					

Procurement of Web Based Protection Database Management Software and Protection Setting Calculation Tool for North Eastern Region

Substation Name	Rated Voltage (in kV)	3Ph to ground fault		SLG fault	
		Fault MVA	Fault Current (in kA)	Fault MVA	Fault Current (in kA)
Palatana	400	5025.365	7.253	5430.182	7.838
	132	2394.134	10.472	2105.653	9.21
Surajmani Nagar	132	2336.617	10.22	1474.792	6.451
Monarchak	132	1535.479	6.716	1411.765	6.175
Kumarghat PG	132	2575.847	11.266	1834.807	8.025
P K Bari	132	2542.176	11.119	1792.442	7.84
Dharmnagar	132	1168.238	5.11	656.683	2.872
Kailasahar	132	1217.534	5.325	705.371	3.085
Kamalpur	132	1405.219	6.146	853.216	3.732
Dhalabil	132	1114.026	4.873	646.562	2.828
Ambassa	132	1345.375	5.884	843.919	3.691
Udaipur	132	1745.568	7.635	1242.376	5.434
	66	385.536	3.373	354.003	3.097
Agartala	132	2690.469	11.768	2064.152	9.028
	66	152.072	1.33	124.918	1.093
Bodhjangnagar	132	2225.414	9.734	1526.748	6.678
Jirani	132	1532.633	6.704	1055.248	4.616
Baramura	132	1317.591	5.763	1014.791	4.439
	66	250.948	2.195	289.283	2.531
Rokhia	132	1928.47	8.435	1721.713	7.531
	66	333.267	2.915	312.237	2.731
Teliamura (GAMAITILLA)	132	1195.834	5.23	821.662	3.594
	66	217.247	1.9	211.772	1.853
Rabindranagar	132	1460.379	6.387	1291.808	5.65
	66	331.055	2.896	307.579	2.691
Badharghat	66	140.647	1.23	111.997	0.98
Belonia	66	137.206	1.2	94.295	0.825
Bagafa	66	192	1.68	135.399	1.184
Sabroom	66	108.193	0.946	70.154	0.614
Satchand	66	131.592	1.151	87.217	0.763
Amarpur	66	120.403	1.053	89.649	0.784
Gakulnagar	66	119.016	1.041	89.677	0.784
Gumti	66	135.489	1.185	90.138	0.789
Boxnagar	66	298.086	2.608	261.361	2.286
Ompi	66	156.841	1.372	127.756	1.118
Jatanbari	66	161.753	1.415	110.468	0.966
Bishramgaunj	66	235.816	2.063	174.89	1.53



राजीव शर्मा
अध्यक्ष एवं प्रबंध निदेशक
RAJEEV SHARMA
Chairman & Managing Director



पावर फाइनेंस कारपोरेशन लिमिटेड
POWER FINANCE CORPORATION LTD.
(भारत सरकार का उपक्रम) (A Govt. of India Undertaking)

D.O.No 04/ITP-28/18-19/VNLTL/TSA
January 07, 2019

Dear Sir,

Sub: Signing of Transmission Service Agreement (TSA) for Independent Transmission Project (ITP) for "Western Region Strengthening Scheme- XIX (WRSS-XIX) and North Eastern Region Strengthening Scheme- IX (NERSS-IX)" – Reg.,

Dear Sir,

1. Ministry of Power (MoP), Gol, vide Gazette Notification dated May 04, 2018 had appointed PFC Consulting Limited (PFCCL) as the Bid Process Coordinator (BPC) for the subject Independent Transmission Project i.e "Western Region Strengthening Scheme- XIX (WRSS-XIX) and North Eastern Region Strengthening Scheme- IX (NERSS-IX)" to be developed through Tariff Based Competitive Bidding Process (TBCB) under "Tariff Based Competitive Bidding Guidelines for Transmission Services , (the Guidelines) issued by MoP, Gol.
2. It may be noted that the above transmission scheme was deliberated and approved in 39th, 41st and 42nd WR SCM held on 30.11.2015, 21.12.2016 & 17.11.2017 respectively and 17th TCC/NERPC meeting held on 04.10.2016. Further, the scheme was also approved on 06.08.2018 for implementation through TBCB route by Empowered Committee on Transmission, MoP, Gol.
3. As per the Guidelines, a **Transmission Service Agreement (TSA) is to be executed amongst SPV and all the Regional Beneficiaries i.e Long Term Transmission Customers (LTTCs) for the project.**
4. As per CEA letter no CEA-PS-11-16(14)/1/2018-PSPA-I Division dated 2/11/2018, the TSA is to be signed by following LTTCs in Western Region and North Eastern Region.

a) Western Region Constituents:

- i) Maharashtra State Electricity Distribution Company Limited
- ii) Gujarat Urja Vikas Nigam Limited
- iii) M.P. Power Management Company Limited
- iv) Chhattisgarh State Power Distribution Company Limited
- v) Goa Electricity Department
- vi) Electricity Department, Daman & Diu
- vii) DNH Power Distribution Corporation Limited

b) North Eastern Region Constituents:

- i) Department of Power, Arunachal Pradesh
 - ii) Assam Electricity Grid Corporation Limited
 - iii) Manipur State Power Distribution Company Limited
 - iv) Meghalaya energy Corporation Limited
 - v) Department of Power, Govt. of Nagaland
 - vi) Department of Power & Electricity, Govt. of Mizoram.
 - vii) Tripura State Electricity Corporation Limited
5. Accordingly, PFCCL as a BPC, vide its earlier letter dated 27.11.2018 had requested all above LTTCs of Western Region and North Eastern Region Constituents for signing the TSA on 07.12.2018 in Delhi but due to absence of Authorized Signatory, the TSA could not be signed.
6. It may be noted that, the RfQ Stage of the bid has been completed and RfP documents has been issued to the shortlisted bidders on 13.11.2018. **The last date of submission of RfP bids would be before end 31.01.2019 so that LoA and transfer of SPV to the Successful Bidder is completed at the earliest during the FY 2018-19.**
7. To facilitate signing of TSA, it is proposed that PFCCL officials will coordinate with Authorized Signatory of your Utility and will visit in person as per schedule enclosed at **Annex I**, so that the signed TSA can be issued to the prospective bidders at least 7 days prior to the RfP Bid submission due date. Further, a background note to expedite the signing of TSA is enclosed at **Annex II** for your kind reference.
8. I request you that needful approval may kindly be accorded so that TSA is signed by the Authorized Signatory as per proposed schedule.

Regards

Yours sincerely,

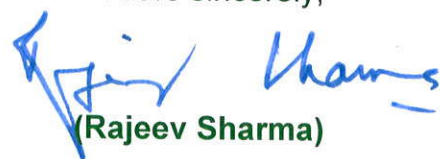
(Rajeev Sharma)

Encl: As above

To,
Sri Satyendra Nath Kalita
Managing Director,
Assam Electricity Grid Corporation Limited,
Bijulee Bhawan, 4th Floor,
Paltan Bazar, Guwahati - 781 001
Email: managing.director@aegcl.co.in;

Copy for kind information to:

1. Member (Power System), Central Electricity Authority, Sewa Bhawan, R.K. Puram, New Delhi – 110 066.
2. Joint Secretary (Transmission), Ministry of Power, Shram Shakti Bhawan, Rafi Marg, New Delhi – 110 001.
3. Chief Engineer (PSPA-I), Central Electricity Authority, Sewa Bhawan, R.K. Puram, New Delhi – 110 066.
4. Member Secretary, North Eastern Regional Power Committee, NERPC Complex, Dong Parmaw, Lapalang, Shillong – 793006 (Meghalaya)
5. Chief Operating Officer (CTU), Power Grid Corporation of India Ltd. "Saudamini" Plot No. 2, Sector – 29 Gurgaon – 122001.

List of Long Transmission Customers (LTTC) for “Western Region Strengthening Scheme- XIX (WRSS-XIX) and North Eastern Region Strengthening Scheme- IX (NERSS-IX)”		Proposed Date for Signing of TSA
1.	Sh. Sanjeev Kumar, IAS Chairman & Managing Director, Maharashtra State Electricity Distribution Company Limited, Hongkong Bank Building, M.G. Road, Fort, Mumbai-400001 Email: md@mahadiscom.in ; mdmsedcl@gmail.com ;	14.01.2019
2.	Shri Pankaj Joshi, IAS Managing Director Gujarat Urja Vikas Nigam Limited, Sardar Patel Vidyut Bhavan, Race Course, Vadodara 390 007 Gujarat, India Email: md.guvnl@gebmail.com ;	15.01.2019
3.	Sh. Sanjay Kumar Shukla (IAS) Managing Director M.P. Power Management Company Limited Shakti Bhawan, Vidyut Nagar, Rampur Jabalpur (M.P.) Email: shukla.sanjay@mppmcl.com ;	16.01.2019
4.	Sh. Ankit Anand, IAS Managing Director Chhattisgarh State Power Distribution Company Limited Vidhyut Sewa Bhawan, Danganiya, Raipur-492013, Chhattisgarh Email: mddiscom@cspc.co.in ; mddiscom@gmail.com ;	17.01.2019
5.	Sh. Shri M. R. Ingle Executive Engineer Vidyut Bhavan, Near 66/11 Kv Kachigam Sub-Station, Somnath - Kachigam Road, Kachigam, Daman-396210. Email : elec-dmn-dd@nic.in ;	18.01.2019
6.	Sh. Kannan Gopinathan, IAS, Managing Director, DNH Power Distribution Corporation Limited, Vidhyut Bhavan, 66 KV Road, Near Secreteriat, AmlI, Silvassa - 396230, U.T. of Dadra & Nagar Haveli. E-mail : md.dnhpdcl@gov.in ;	21.01.2019
7.	Smt. Reshma Mathew Chief Electrical Engineer, The Chief Electrical Engineer, Electricity Department, 3rd Floor, Vidyut Bhawan, Panajim, Goa cee-elec.goa@nic.in ; reshma.m@goaelectricity.gov.in ;	22.01.2019
8.	Sri Satyendra Nath Kalita Managing Director, Assam Electricity Grid Corporation Limited,	24.01.2019

List of Long Transmission Customers (LTTC) for “Western Region Strengthening Scheme- XIX (WRSS-XIX) and North Eastern Region Strengthening Scheme- IX (NERSS-IX)”		Proposed Date for Signing of TSA
	Bijulee Bhawan, 4th Floor, Paltan Bazar, Guwahati - 781 001 Email: managing.director@aeqcl.co.in ;	
9.	Sh. Yeshi Tsering, IAS Chairman-cum-Managing Director, Meghalaya Energy Corporation Limited Lumjingshai, Short Round Road, Shillong-793001 Meghalaya, India Email : ytsering(at)yahoo.com	24.01.2019
10.	Sh. L. Priyokumar Singh Managing Director Manipur State Power Distribution Company Limited 3rd Floor, New Directorate Building, Near 2nd MR Gate, Imphal-Dimapur Road, Manipur – 795001 Email: pk.laishram@yahoo.com ;	25.01.2019
11.	Sri H. Lalengmawia Secretary to Gov. of Mizoram Power and Electricity Department Room No. 201, Annex- II Opposite Mizoram Legislative Assembly house Treasury Square, Aizawal, Mizoram 796001 Ph: 0389-2310908 Email : spower.mizo@gmail.com ;	28.01.2019
12.	Chief Engineer (T&G) Department of Power, Govt. of Nagaland, Electricity House, A.G. Colony, Kohima-797001 Email: Cepower1@gmail.com ;	29.01.2019
13.	Sh. Anong Perme Chief Engineer (P) Vidyut Bhawan, Department of Power, Govt. of Arunachal Pradesh, Itanagar-791111 Email: vidyutarunachal@rediffmail.com ;	30.01.2019
14.	Dr. Murhari Sopanrao Kela, Chairman Cum Managing Director, Tripura State Electricity Corporation Limited, Bidyut Bhavan, Banamalipur, Agartala, Tripura-799007 Email: cmd.tsecl@rediffmail.com ;	31.01.2019

Background Note for Signing of Transmission Service Agreement by Long Term Transmission Customers for the transmission scheme "Western Region Strengthening Scheme - XIX (WRSS-XIX) and North Eastern Region Strengthening Scheme - IX (NERSS-IX)"

1.0 Background

1.1 The tariff based competitive bidding in Transmission was initiated in 2008 subsequent to the Ministry of Power, Government of India notifying the Guidelines ("Tariff Based Competitive Bidding Guidelines for Transmission Service" and "Guidelines for Encouraging Competition in Development of Transmission Projects") in April, 2006 and all the Standard Bidding Documents (i.e. Request for Qualification, Request for Proposal & Transmission Service Agreement) in September 2008.

Further, as per Tariff Policy notified by Govt. of India, after January 5, 2011 it is mandatory that all investment in the transmission projects, including inter-state transmission projects, by transmission developer including CTU and STU are through Tariff Based Competitive Bidding with some exclusions as given below:

- i) First two experimental works for 1200kV HVDC line
- ii) Works required to be done to cater to an urgent situation or which are required in compressed time schedule by CTU/STUs as decided by the Central Govt. On a case to case basis.
- iii) The intra-state transmission projects by STUs will be exempted from competitive bidding route for a further 2 years beyond 6.1.2011.
- iv) The upgradation/strengthening of the existing transmission lines and associated sub-stations.
- v) Projects for which BPTA(s)/TSA(s) have been signed on or before 05.01.2011.

1.2 For the development of Independent Transmission Projects (ITPs), PFC Consulting Limited (PFCCL) and REC Transmission Projects Company Ltd (RECTPL) have been appointed as 'Bid Process Coordinator' by Ministry of Power, Govt. of India.

- 1.3 The objective of this initiative is to develop transmission capacities in India and to bring in potential investors after developing such projects to a stage having preliminary survey work, identification of route, preparation of survey report, initiation of process of land acquisition, initiation of process of seeking forest clearance, if required and to conduct bidding process etc.
- 1.4 For carrying out the initial developmental activities for the transmission projects, Special Purpose Vehicle (SPV) companies are incorporated which are transferred to the Successful Bidder selected through tariff based international competitive bidding
- 1.5 As per the Guidelines issued by Ministry of Power, a Transmission Service Agreement (TSA) will be signed among the SPV and the concerned Beneficiaries for payment of the transmission charges finalized on the basis of competitive bidding and accepted by the appropriate Commission.
- 1.6 In line with the requirement of the RfP documents, the copy of the duly executed TSA is to be made available to the Bidders 7 days prior to the last date of submission of RfP bids.
- 2.0 **Signing of TSA for the Transmission Scheme “Western Region Strengthening Scheme - XIX (WRSS-XIX) and North Eastern Region Strengthening Scheme - IX (NERSS-IX)”**
- 2.1 Ministry of Power vide Gazette Notification dated May 04, 2018 appointed PFC Consulting Limited (PFCCL) as Bid Process Coordinator for the purpose of selection of Bidder as Transmission Service Provider (TSP) to establish transmission system for “Western Region Strengthening Scheme - XIX (WRSS-XIX) and North Eastern Region Strengthening Scheme - IX (NERSS-IX)” through tariff based competitive bidding process.

The Scheme comprises the following:

Part A- Additional 400kV outlets from Banaskantha 765/400 kV S/s

- LILO of second circuit of Zerda – Ranchodpura 400 kV D/c line at Banaskantha (PG) PS

Part B- Establishment of new substation at Vapi/Ambethi area and its associated transmission lines.

- Establishment of 2 x 500 MVA, 400/220 kV S/s near Vapi / Ambheti (Vapi – II)
- LILO of KAPP – Vapi 400 kV D/c line at Vapi – II
- 125 MVA bus reactor at Vapi – II Substation
- Vapi-II – Sayali D/C 220kV line.
 - From Vapi-II upto LILO point of one circuit of Vapi(PG) –Khadoli 220kV D/c line at Sayali substation with ampacity equivalent to twin zebra conductor.
 - Interconnection with LILO section (of LILO of one circuit of Vapi(PG) – Khadoli 220kV D/c line at Sayali substation) so as to form Vapi-II – Sayali 220 kV D/c line and Vapi- Khadoli 220 kV D/c line. (The LILO section is with zebra conductor)

Part C: Additional ISTS feed to Navi Mumbai 400/220 kV substation of POWERGRID

- Padghe (PG) – Kharghar 400 kV D/c (quad) line to be terminated into one ckt. of Kharghar – Ghatkopar 400 kV D/c (quad) line (thus forming Padghe (PG) - Kharghar 400 kV S/c (quad) line, Padghe (PG) - Ghatkopar 400 kV S/c (quad) line)
- LILO of Padghe (PG) – Ghatkopar 400kV S/c line at Navi Mumbai GIS (PG) (with quad conductor)
- LILO of Apta – Kalwa/Taloja 220 kV D/c line (i.e. Apta – Kalwa and Apta Taloja 220kV lines) at Navi Mumbai (PG)

Part D: North Eastern Region Strengthening Scheme – IX

- Pare HEP (NEEPCO) (from near LILO point)– North Lakhimpur (AEGCL) 132 kV D/c line (with ACSR Zebra conductor) along with 2 no. 132 kV line bays at North Lakhimpur end.

- LILO of one circuit of Pare HEP – North Lakhimpur (AEGCL) 132kV D/c line (with ACSR Zebra) at Nirjuli (POWERGRID) substation
- 2.2 The scheme was approved in 2nd meeting of Empowered Committee on Transmission held on 06.08.2018
- 2.3 The scheme was approved in the 1st meeting of National Committee on Transmission (NCT) 27.07.2018
- 2.4 The scheme was approved in the 39th WR SCM held on 30.11.2015, 41st WR SCM held on 21.12.2016 & 42nd WR SCM 17.11.2017 in the 17th TCC/NERPC meeting held on 04.10.2016
- 2.5 CEA in the minutes of meeting held on 24th June, 2013 chaired by member (PS), CEA in which BPC was directed for signing of TSA by regional constituents in which the scheme is approved.
- 2.6 CEA vide its letter no CEA-PS-11-16(14)/1/2018-PSPA-I Division dated 2/11/2018 has furnished the details of Long Term Transmission Customers (LTTCS) for the scheme for signing the TSA.

Western Region Constituents

- i) Chhattisgarh State Power Distribution Company Limited
- ii) Goa Electricity Department
- iii) Maharashtra State Electricity Distribution Company Limited
- iv) DNH Power Distribution Corporation Limited
- v) Gujarat Urja Vikas Nigam Limited
- vi) M.P. Power Management Company Limited

North Eastern Region Constituents

- i) Department of Power, Arunachal Pradesh
- ii) Assam Electricity Grid Corporation Limited
- iii) Manipur State Power Distribution Company Limited
- iv) Meghalaya energy Corporation Limited

- v) Department of Power, Govt. of Nagaland
- vi) Department of Power & Electricity, Govt. of Mizoram.
- vii) Tripura State Electricity Corporation Limited

3.0 Status of the Bid Process

- RfQ stage completed.
- Short listing of bidders at RfQ stage was declared on October 26, 2018 for participating in the next stage of bidding i.e RfP.
- RfP documents issued to the shortlisted bidders w.e.f November 13, 2018.
- **As CEA is revising scope of work which will be finalized up this week, the bidders would be submitting the RfP bids by January 31, 2019.**
- **The copy of the duly executed TSA is to be made available to the Bidders 7 days prior to the last date of submission of RfP bids.**

भारत सरकार Government of India
विद्युत मंत्रालय Ministry of Power
उत्तर पूर्वी क्षेत्रीय विद्युत समिति
North Eastern Regional Power Committee
एन ई आर पी सी कॉम्प्लेक्स, डोंग पारमाओ, लापालाड, शिल्लोंग-७९३००६, मेघालय

**Subject: CPCB Directions under Section -5 of Environmental (Protection) Act, 1986
to Bongaigoan TPP of NTPC – Reg.**

Ref: CEA/Th/TPE&CC/ENV/50/2019/14-15 dated 07.01.2019.

With reference to the subject above & CEA letter dated 07.01.2019, NERPC had taken up the matter with NTPC, Bongaigoan regarding phasing plan for implementation of new environmental norms for coal based power plant of BgTPP.

NTPC vide their letter dated 19.01.2019 has furnished the reply and the same is attached herewith for further necessary action.

Encl: As above

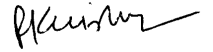

P. K. Mishra

Member Secretary

Chief Engineer (TPE&CC), CEA, Sewa Bhawan, R.K.Puram, New Delhi – 110066
No. NERPC/SE (O)/CEA/2019/ **1891-1892** Date 22nd January, 2019

Copy to:

The RED (East –II), HQR, (NTPC), 3rd Floor, OLIC Bldg., PI No- N.17/2, Nayapalli,
Bhubaneswar-751012 for necessary compliance.



भारत सरकार/Government of India
विद्युत मंत्रालय/Ministry of Power
केन्द्रीय विद्युत प्राधिकरण/Central Electricity Authority/
तापीय निष्पादन मूल्यांकन एवं बदलवायु परिवर्तन प्रभाग
Thermal Performance Evaluation & Climate Change Division

Subject: CPCB Directions under Section – 5 of Environmental (Protection) Act, 1986 to Bongaigaon TPP of NTPC- reg.

Ministry of Power (MoP) vide letter No. 10/1/2018- St Th. dated 21.12.2018 has requested comments of CEA on the subject matter. The comments of CEA are as mentioned below:

1. CEA has prepared phasing plan for implementation of new environmental norms based on the inputs received from the various power generators during meetings called by RPCs for this purpose. For Bongaigaon TPP, NTPC informed that FGD is under implementation and no specific date was provided for the same. Bongaigaon TPP is the alone coal based power station in the NE Region.
2. Now, NTPC has represented that due to various reasons mentioned in the letter, FGDs at Bongaigaon TPP could not be implemented. In such a situation, NTPC may approach NERPC to get a suitable time slot for shut down of its units up to December 2022 for installation/commissioning of FGDs at its units. This is also in line with the time provided to other units to comply with the norms as per the phasing plan and CPCB directions issued to them.
3. Based on the dates provided by NERPC, MoP may write to MoEF&CC for providing exemption to NTPC to run the units at Bongaigaon TPP till the implementation of FGD as per the schedule given by NERPC.

This issues with the approval of Member (Thermal).

o/c

(Akhilesh Prasad)
Deputy Director

A K Deveshwar, Section Officer, Ministry of Power
No. CEATh/TPE&CC/ENV/50/2019/ 14-15

Date: 4.1.2019
7

Copy to: MS, NERPC

सेवाभवन, आर.के. पुरम, नई दिल्ली-110066, टेलिफेक्स: 011-26105075 ईमेल: directorcore@yahoo.com वेबसाइट: www.cea.nic.in
SewaBhawan, R.K.Puram, New Delhi-110066, Telefax: 011-26105075 E-mail: directorcore@yahoo.com Websit: www.cea.nic.in

Urgent

SECO

Pl. discam

8/1/19



एनटीपीसी लिमिटेड
NTPC Limited
Bongaigaon

Ref. No. BgTPP/HOP/

Date: 19.01.2019

To
The Member Secretary,
NERPC
Nongrim Hills, Shillong - 793003.

Sub: Shut down proposal for unit # 1, 2 & 3 of Bongaigaon TPP in the year 2021 & 2022 for implementation of FGD system.

Dear Sir,

NTPC Bongaigaon TPP (3x250 MW) is located in the North Eastern Region of India, which has limited transmission capacity with National Grid.

As FGD plant was already awarded and under installation at Bongaigaon, so it was not included in the Phasing Plan prepared by CEA.

The construction of FGD plant has not been completed within stipulated time due to various project implementation issues such as project located in the heart of Bodoland area of Assam, frequent bandhs, excessive rainfall, law and order issues, contractor turnout etc.

As per MOP/Supreme Court guideline FGD is required to be installed in all power plants before December 2022. Bongaigaon TPP (3x250 MW) is located in the North Eastern Region of India, which has limited transmission capacity with National Grid and the operation of the project will help in supporting the uninterrupted power supply position in North Eastern region. Considering the above a unit wise Phasing Plan for FGD implementation is to be made. The detail of tentative shutdown planned in 2021-2022 & 2022-23 is as tabulated below for your consideration

	Date of tentative Planned Shutdown
Unit-I	December 2021
Unit-II	September 2022
Unit-III	December 2022

It is therefore requested to kindly schedule Bongaigaon TPP (3x250 MW) in the Phasing Plan for FGD implementation as per above schedule and accordingly dates of implementation of FGD may please be intimated to MOP.

Thanking you,

Yours faithfully,

(Dipankar Bose)
Executive director (BgTPP)

Enclosure:

1) CEA letter ref. no. CEA/Tb/TPE&CC/ENV/50-2019/14-15

एनटीपीसी लिमिटेड, बीजीटीपीपी, सालाकाटी (पी), जिला: कोकराझार (बीटीएडी) असम
NTPC LIMITED, Bg.T.P.P. Salakati (P), Dist.: Kokrajhar (BTAD) Assam

टेली फैक्स नं./Tele Fax No. 03661-282727

Procedure for interconnection of a new Non-ISTS Elements of 400 kV and above voltage level connected to nodes of Intra STS

National Load Despatch Centre(NLDC) vide letter dated 26th May 2014, issued procedure for inter connection of a new transmission element belonging to any transmission licensee, which is a part of inter-state transmission system.

As per clause no. 4.1 & 4.2 of CEA (Technical Standards for Connectivity to the Grid) regulations, 2007; a new connection shall not cause any adverse effect on safe operation, integrity and reliability of the grid.

In order to ensure the safe operation, integrity and reliability of the regional grid while **charging new Non-ISTS Elements of 400 kV and above voltage level connected to nodes of Intra STS**, the following procedure has been developed based on **NLDC** Procedure for interconnection of a new transmission element, which is a part of inter-state transmission system, belonging to any transmission licensee.

In accordance with the above provisions and as a part of RLDC operating procedure, procedure for interconnection of **new Non-ISTS Elements of 400 kV and above voltage level connected to nodes of Intra STS belonging to any Power Utility** has been formulated to enable RLDCs for secure and reliable interconnection of new elements. The details of the same are as follows:

1. All the **Power Utilities** intending to commission **any Non-ISTS Elements of 400 kV and above voltage level connected to node of Intra STS**, shall intimate the concerned RLDC the details as given below, **generally (10) days** prior to the anticipated date of first test charging through respective SLDC.
 - a. **Annexure A1:** Intimation regarding anticipated charging of the line along with the list of the desired documents being submitted as per **Format I**.
 - b. **Annexure A2:** List of elements to be charged and Element Rating details as per **Format IA**
 - c. **Annexure A3:** Single line diagram of the concerned sub stations, along with status of completion of each dia/bus/breakers clearly indicating which elements are proposed to be charged.

5. On satisfying itself with the submitted information as stated above under Para4, the **SLDC** would issue a provisional approval for charging to the **Power Utility** as per **Format IV** within two days of receipt of above documents. On the designated day, the **Power Utility** shall charge the transmission line, after obtaining the real-time code from **concerned SLDC**. All attempts would be made by the real time operating personnel at the **concerned SLDC** to facilitate charging and commissioning of the new element at the earliest, subject to availability of real time data and favourable system conditions.

Documents to be submitted while commissioning of 400 kV and above voltage level connected to nodes of Intra STS

Annexure	Subject	Remarks
Annexure A1	Intimation regarding anticipated charging of the line along with other documents	As per Format I
Annexure A2	List of elements to be charged and Element Rating details	As per Format I A
Annexure A3	Single line diagram of the concerned substations, along with status of completion of each dia/bus/breakers	
Annexure A4	List of SCADA points to be made available (as per standard requirement, RLDC would need all MW and MVAr data, voltage and frequency of all the buses, all the breaker and isolator positions, OLTC tap positions, Main-1/Main-2 protection operated signals)	
Annexure A5	Type and Location of Energy meters as per relevant CE A regulation	
Annexure A6	Connection Agreement, wherever applicable along with all annexures	
Annexure B1	Request for charging of the new transmission element along with the summary of the undertakings being submitted	As per Format III
Annexure B2	Undertaking in respect of Protective systems	As per Format III A
Annexure B3	Undertaking in respect of Telemetry and communication	As per Format III B
Annexure B4	Undertaking in respect of Energy metering	As per Format III C
Annexure B5	Undertaking in respect of Statutory clearances	As per Format III D

Format I

Intimation by Transmission Licensee regarding anticipated charging of new elements

<Name of Transmission Licensee>

Name of the transmission element :

Type of Transmission Element : Transmission Line / ICT / Bus Reactor / Line Reactor / Bus / Bay / Series Capacitor / Series Reactor

Voltage Level : AC/DC kV Owner of the Transmission Asset

:

Likely Date and time of Charging :

Place:

Date:

(Name and Designation of the authorized person with official seal)

Encl: Please provide full details.

Annexure A2: Format IA: List of elements to be charged and Element Rating details

Annexure A3: Single line diagram of the concerned substations, along with status of completion of each dia/bus/breakers

Annexure A4: List of SCADA points to be made available

Annexure A5: Location of installation of Energy meters as per relevant CEAR regulations

Annexure A6: Connection Agreement, if applicable along with all annexures

FormatIA

List of elements to be charged and Element Rating details

I. List of Elements to be charged:

II. Element Ratings

a. Transmission Line

1	FromSubstation	
2	ToSubstation	
3	Voltage Level (kV)	
4	LineLength(km)	
5	ConductorType	
6	Noofsub Conductors	

b. ICT

1	Voltage(HVkV/LVkV)	
2	Capacity(MVA)	
3	TransformerVectorgroup	
4	Totalnooftaps	
5	NominalTapPosition	
6	PresentTapPosition	
9	Tertiary Winding Rating and Ratio	
10	% Impedance	

c. Shunt/SeriesReactor

1	SubstationName/ LineName	
2	Voltage	
3	MVARRating	
4	Switchable / Non Switchable	
5	In case of Bus Reactor, whether it can be taken as line reactor	

(NameandDesignationoftheauthorizedpersonwithofficialseal)

< Name and Address of Transmission Licensee >

Undertaking by Transmission Licensee in respect of Energy metering

The following Transmission element is proposed to be charged on tentatively around Hrs.

Name of transmission element:

Special Energy Meters (SEMs) conforming to CEA (Installation and Operation of Meters) Regulations, 2006 have been installed and commissioned. The SEMs are calibrated in compliance of regulation 9 of Part-I of CEA (Technical Standard for Grid Connectivity) Regulations 2007 as per the following details:

S no	Name of substation	Feeder name	Make of meter	Meter no	CT Ratio	PT/CVT Ratio
1	Sending end					
2	Receiving end					

Data Format Conformity: Yes / No
Polarity as per Convention: Yes / No
Time Drift Correction carried out: Yes/No

The data from the above meters would be forwarded on weekly basis to the RLDC as per section 6.4.21 of the Indian Electricity Grid Code (IEGC) (as amended from time to time) and also as and when requested by the RLDC.

Place:
Date:

(Name and Designation of the authorized person with official seal)

Format II

**<Name of RLDC> Acknowledgement
of Receipt by RLDC**

This is to acknowledge that the intimation of likely charging of (Name of the transmission element) has been received from (Name of the owner of the transmission asset) on (Date).

Kindly complete the technical formalities in connection with energy metering, protection and real time data and communication facilities and inform us of the same three (3) days before charging of the above transmission element as per Formats III, IIIA, IIIB, IIIC and IIID.

Or

The intimation is incomplete and the following information may be submitted within three (3) days of issue of this acknowledgment receipt.

1. -
2. _____
3. _____

.....

Date

Signature

Name:

Designation:

RLDC:

Format III

<Name of Transmission Licensee>

**Request by Transmission Licensee for first time charging and
start of Trial Operation**

Past references: Name of the transmission element :

Type of Transmission Element : Transmission Line / ICT / Bus Reactor / Line
Reactor / Bus / Bay

Voltage Level :

Owner of the Transmission Asset

: Proposed Date and time of first time Charging:

Place: Date:

(Name and Designation of the authorized person with official seal)

Encl:

Annexure B2: Undertaking in respect of Protective systems as per Format IIIA

Annexure B3: Undertaking in respect of Telemetry and communication as per Format IIIB

Annexure B4: Undertaking in respect of Energy metering as per Format IIIC

Annexure B5: Undertaking in respect of Statutory clearances as per Format IIID

Format IIIA

< Name and Address of Transmission Licensee >

Undertaking by Transmission Licensee in respect of Protective systems

The following transmission element is proposed to be charged on <date> tentatively _____ around _____ hours.

S/No and Name of transmission element:

- 1.0 It is certified that all the systems as stipulated in Part-III of the Central Electricity Authority (Technical Standards for Connectivity to the Grid) Regulations, 2007 (as amended from time to time) have been tested and commissioned and would be in position when the element is taken into service.
- 2.0 The protective relay settings have been done as per the guidelines of the Regional Power Committee (RPC) as per section 5.2 of the Indian Electricity Grid Code (IEGC). The necessary changes have also been made/would be made appropriately for the following lines at the following substations:

S/No:	Name of the substation	Name of the line

Place:

Date:

(Name and Designation of the authorized person with official seal)

Format IIIB

**< Name and Address of Transmission Licensee >
Undertaking by Transmission Licensee in respect of Telemetry and communication**

The following transmission element is proposed to be charged on <date> tentatively _____ around _____ hours.

Sno and Name of transmission element:

The list of data points that would be made available to RLDC in real time had been indicated vide communication

dated _____. It is certified that the following data points have been mapped and real time data would flow to RLDC immediately as the element is charged and commissioned.

S no	Name of substation	Data point (analog as well as digital) identified in earlier Communication dated	Point to point checking done jointly with RLDC (Y/N)	Data would be available at RLDC (Y/N)	Remarks (path may be specified)
1	Sending end	Analog			
		Digital			
		SoE			
		Main Channel			
		Standby Channel			
		Voice Communication (Specify)			
2	Receiving end	Analog			
		Digital			
		SoE			
		Main Channel			
		Standby Channel			
		Voice Communication (Specify)			

It is also certified that the data through main channel is made available to RLDC as well as alternate communication channel is available for data transfer to RLDC to ensure reliable and redundant data as per IEGC (as amended from time to time). Also, Voice communication is established as per IEGC. The arrangements are of permanent nature. In case of any interruption in data in real time, the undersigned undertake to get the same restored at the earliest.

Place:

Date:

(Name and Designation of the authorized person with official seal)

Format IIC

< Name and Address of Transmission Licensee>

Undertaking by Transmission Licensee in respect of Energy metering

The following transmission element is proposed to be charged on <date> tentatively around ____ hours.

Sl.No. and Name of transmission element:

Special Energy Meters (SEMs) conforming to CEA (Installation and Operation of Meters) Regulations, 2006 have been installed and commissioned. The SEMs are calibrated in compliance of regulation 9 of Part-I of CEA (Technical Standard for Grid Connectivity) Regulations 2007 as per the following details:

Sl no	Name of substation	Feeder name	Make of meter	Meter no	CT Ratio	PT/CVT Ratio
1	Sending end					
2	Receiving end					

Data Format Conformity: Yes / No

Polarity as per Convention: Yes / No

Time Drift Correction carried out: Yes/No

The data from the above meters would be forwarded on weekly basis to the RLDC as per section 6.4.21 of the Indian Electricity Grid Code (IEGC) (as amended from time to time) and also as and when requested by the RLDC.

(RLDC to indicate the email ids where the data has to be forwarded).

Place:

Date: (Name and Designation of the authorized person with official seal)

Format III D

< Name and Address of Transmission Licensee >

Undertaking by transmission licensee in respect of statutory clearances

It is hereby certified that all statutory clearances in accordance with relevant CERC Regulations / CEA standards / CEA regulations and PTCC route approval for charging of _____ have been obtained from the concerned authorities.

Place:

Date:

(Name and Designation of the authorized person with official seal)

Format IV

Approval for charging

<Name of SLDC>

For Approval no:

To,

The Transmission Licensee,

Sub: Charging of <Name of Transmission element> ---- Provisional approval

**Ref: 1) Your application dated in Format-I
2) RLDC response dated in Format-II
3) Your request and details forwarded on dated in Format III, IIIA, IIIB, IIIC and IIID**

Madam/Sir,

- 1) The above documents have been examined by SLDC and permission for charging of <Name of Transmission element> on or after _ is hereby accorded. This approval is provisional and in the intervening period, if any of the conditions given in the undertakings submitted by you are found to be violated, the approval stands cancelled. Kindly obtain a real time code from the appropriate SLDC for each element switching.
- 2) The following shortcomings have been observed in the documents at Sno 3) above.
 - a.
 - b.
 - c.

Please rectify the above shortcomings at the earliest to enable SLDC to issue the provisional approval for test charging and commissioning of <Name of transmission element>.

Thanking you,

Yours faithfully,

(Name and designation of authorized personnel with seal)

Procedure for interconnection of a new Transmission Element of 132 kV and above voltage level connected to node of Intra STS

National Load Despatch Centre (NLDC) vide letter dated 26th May 2014, issued procedure for interconnection of a new transmission element belonging to any transmission licensee, which is a part of inter-state transmission system.

As per clause no. 4.1 & 4.2 of CEA (Technical Standards for Connectivity to the Grid) regulations, 2007; a new connection shall not cause any adverse effect on safe operation, integrity and reliability of the grid.

In order to ensure the safe operation, integrity and reliability of the regional grid while **charging new Transmission Element of 132 kV and above voltage level connected to node of Intra STS**, the following procedure has been developed based on **NLDC Procedure** for interconnection of a new transmission element, which is a part of inter-state transmission system, belonging to any transmission licensee.

In accordance with the above provisions and as a part of RLDC operating procedure, procedure for **charging new Transmission Element of 132 kV and above voltage level connected to node of Intra STS** belonging to any **Power Utility** has been formulated to enable RLDCs for secure and reliable interconnection of new elements. The details of the same are as follows:

1. All **Power Utilities** intending to commission **any Transmission Element of 132 kV and above voltage level connected to node of Intra STS**, shall submit the following documents to the concerned RLDC, **generally (3) days** prior to the anticipated date of first test charging through respective SLDC:
 - a. **Annexure B2:** Undertaking in respect of Protective systems as per **Format III A**
 - b. **Annexure B3:** Undertaking in respect of Telemetry and communication as per **Format III B**

Format IIIA

< Name and Address of Transmission Licensee >

Undertaking by Transmission Licensee in respect of Protective systems

The following transmission element is proposed to be charged on <date> tentatively _____ around _____ hours.

S/No and Name of transmission element:

- 1.0 It is certified that all the systems as stipulated in Part-III of the Central Electricity Authority (Technical Standards for Connectivity to the Grid) Regulations, 2007 (as amended from time to time) have been tested and commissioned and would be in position when the element is taken into service.
- 2.0 The protective relay settings have been done as per the guidelines of the Regional Power Committee (RPC) as per section 5.2 of the Indian Electricity Grid Code (IEGC). The necessary changes have also been made/would be made appropriately for the following lines at the following substations:

S/No:	Name of the substation	Name of the line

Place:

Date:

(Name and Designation of the authorized person with official seal)

Format IIIB

**< Name and Address of Transmission Licensee >
Undertaking by Transmission Licensee in respect of Telemetry and communication**

The following transmission element is proposed to be charged on <date> tentatively _____ around _____ hours.

Sno and Name of transmission element:

The list of data points that would be made available to RLDC in real time had been indicated vide communication

dated _____. It is certified that the following data points have been mapped and real time data would flow to RLDC immediately as the element is charged and commissioned.

S no	Name of substation	Data point (analog as well as digital) identified in earlier Communication dated	Point to point checking done jointly with RLDC (Y/N)	Data would be available at RLDC (Y/N)	Remarks (path may be specified)
1	Sending end	Analog			
		Digital			
		SoE			
		Main Channel			
		Standby Channel			
		Voice Communication (Specify)			
2	Receiving end	Analog			
		Digital			
		SoE			
		Main Channel			
		Standby Channel			
		Voice Communication (Specify)			

It is also certified that the data through main channel is made available to RLDC as well as alternate communication channel is available for data transfer to RLDC to ensure reliable and redundant data as per IEGC (as amended from time to time). Also, Voice communication is established as per IEGC. The arrangements are of permanent nature. In case of any interruption in data in real time, the undersigned undertake to get the same restored at the earliest.

Place:

Date:

(Name and Designation of the authorized person with official seal)



Introduction
of
Security Constrained Economic Despatch
in
Indian Power System

Implementation of Pilot w.e.f 01st April, 2019

Spatial Distribution of Variable Cost of stations under RRAS

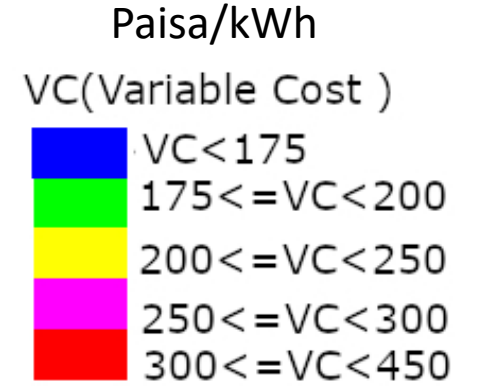
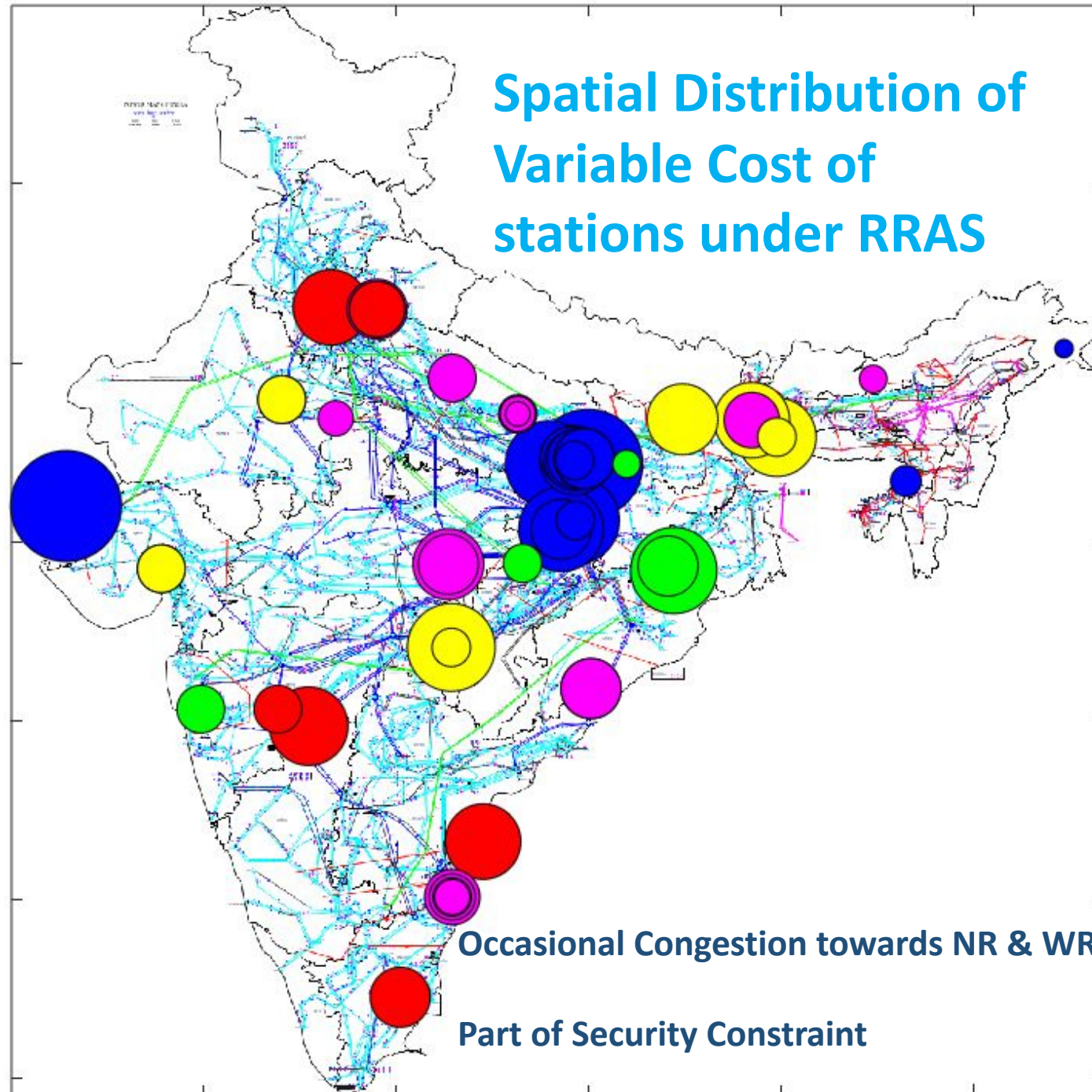

Installed Capacity (MW)

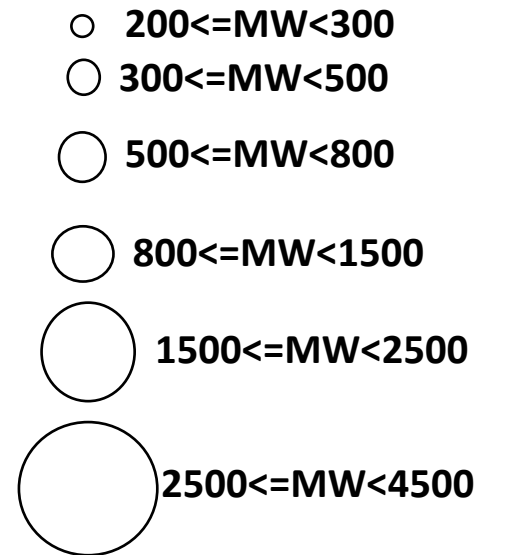

Occasional Congestion towards NR & WR

Part of Security Constraint

RRAS: Reserves Regulation
Ancillary Service

Complexity of Allocations to Beneficiaries Portfolio

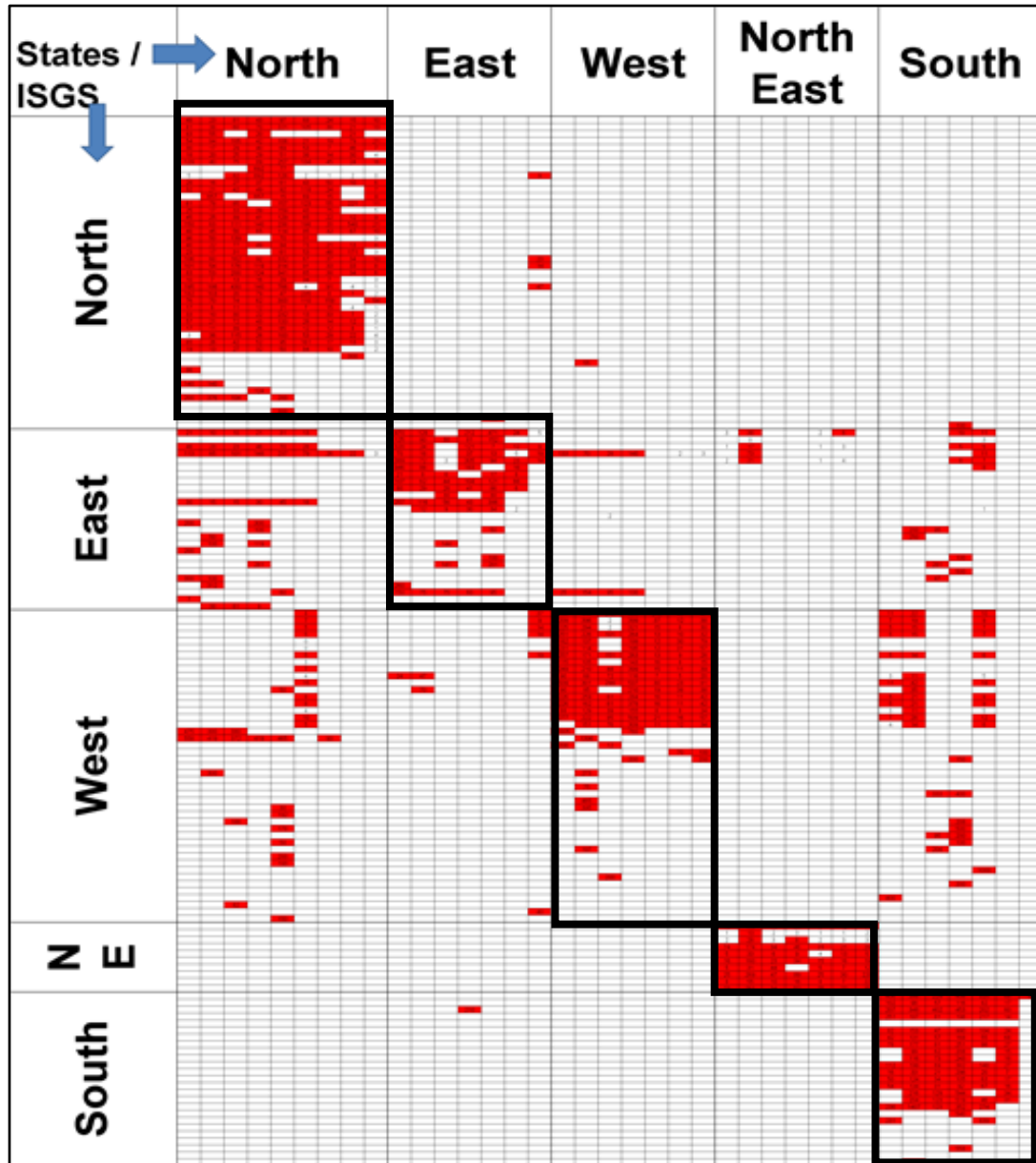

Composition of Allocation Matrix

- ~150 Plants (Inter-State)
- 36 States/UTs
- Approx. half a Million contracts/day (~ 150x 36 x 96)

Need for Optimization

- **Fragmented allocation**
- **Savings in Total Production Costs**
- **Harness Flexibility from Rigid Contracts**

Ease of Implementation

- **Additional Inputs to Existing Multilateral Coordinated Scheduling System**

PLF & Variable Cost

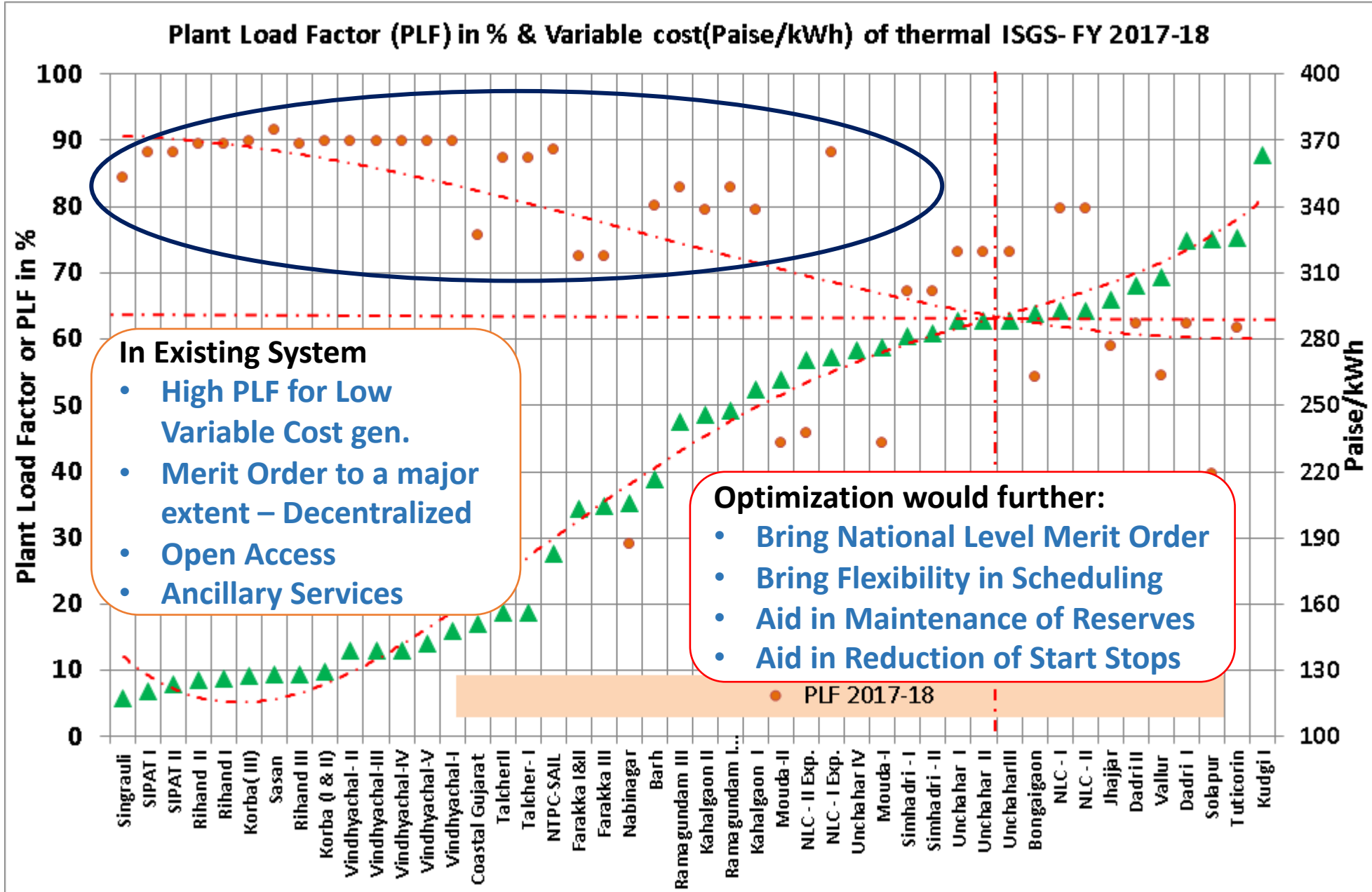

Cumulative Installed Capacity of generation and Variable Cost per unit

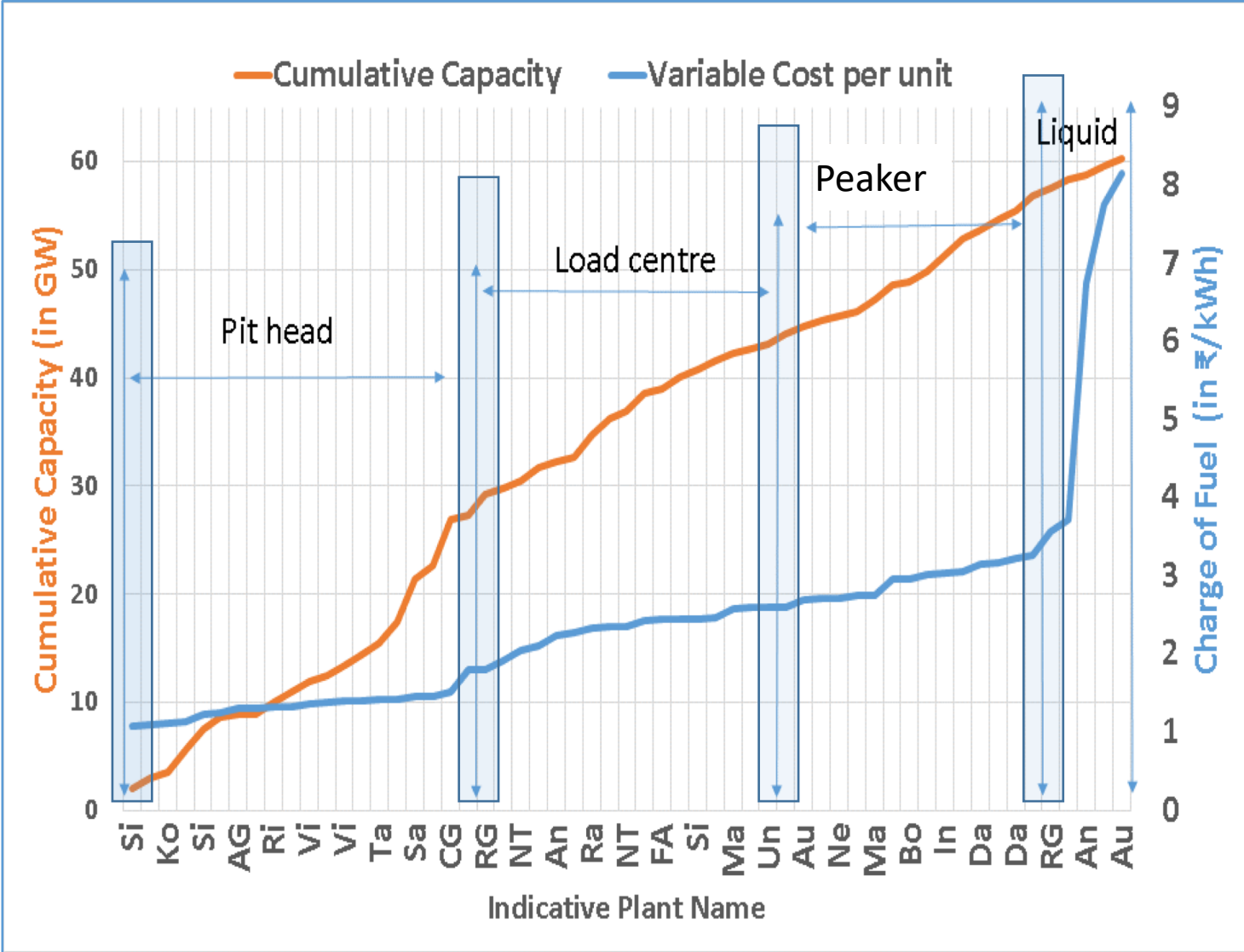

Variable Cost of RRAS Provider

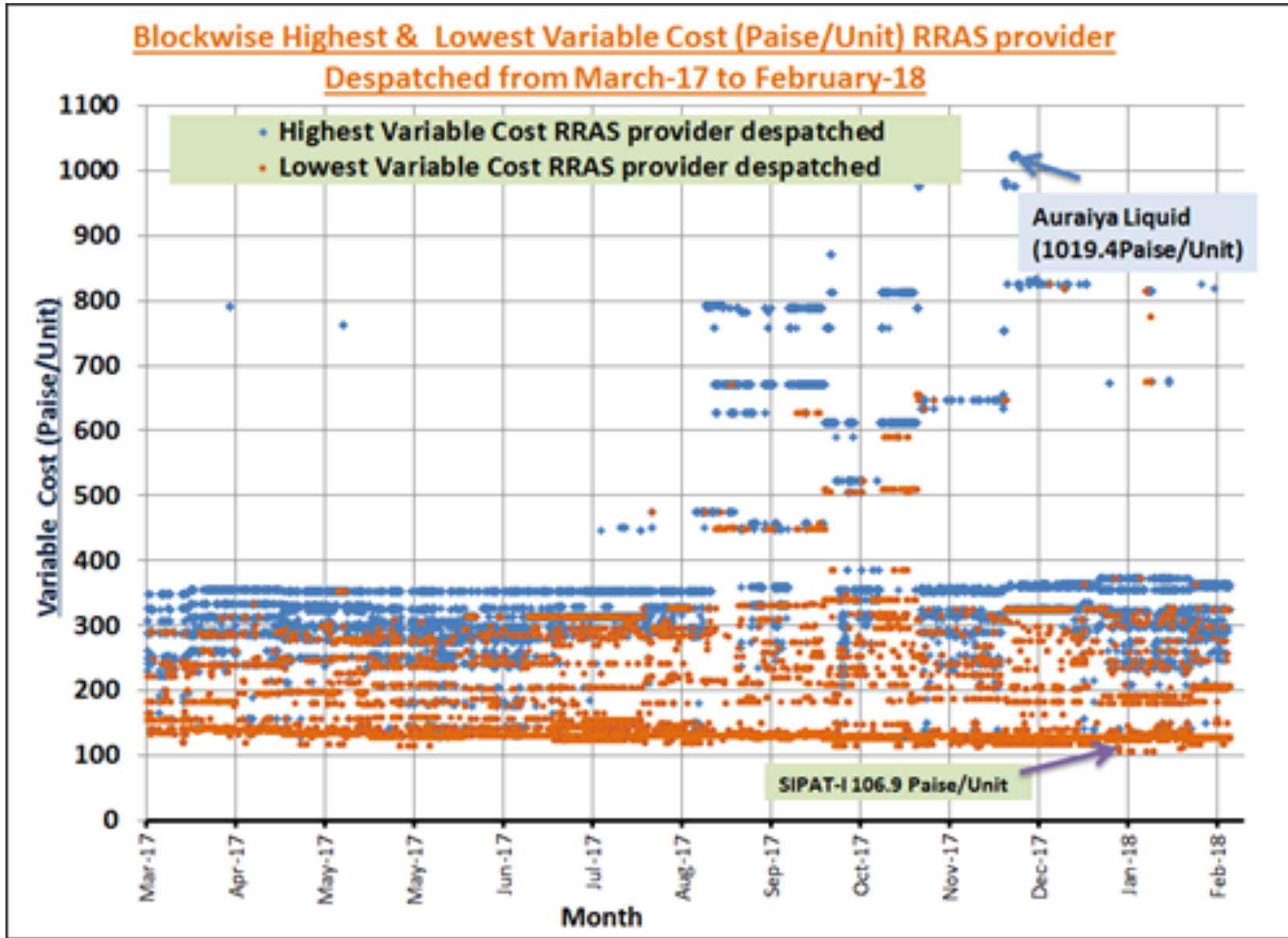

RRAS: Reserves Regulation Ancillary Service

Present Scope

All India Installed Thermal Capacity

■ RLDC - under RRAS
 ■ RLDC - not under RRAS
 ■ SLDC

All India
Total
Installed
Thermal
Capacity
221 GW

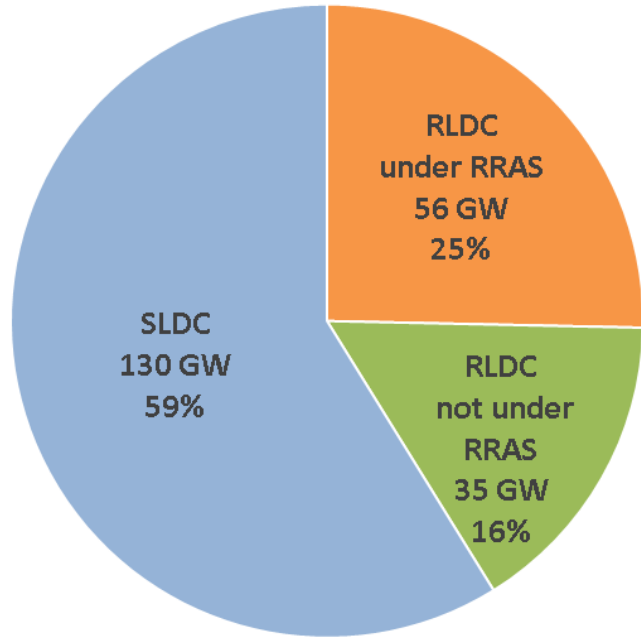

All India Thermal Generation	~ 954 BU / year
Thermal Generation under RRAS	343 BU/ year
% Energy from Plants under RRAS	36%
Weighted average variable charges of Plants under RRAS as per actual dispatch	₹ 1.99 / kWh
Total variable charges for thermal @ ₹ 1.99 /kWh	₹ 190116 crores
Total variable charges for thermal plants under RRAS	₹ 68405 crores (~ 36%)
2022 Thermal Energy as per GtG studies, 1050 BU / year	₹ 230000 crores

RRAS – Reserve Regulation Ancillary Services

GtG – Greening the Grid, USAID

SCED – Security Constrained Economic Dispatch

Inter Regional Power transfer

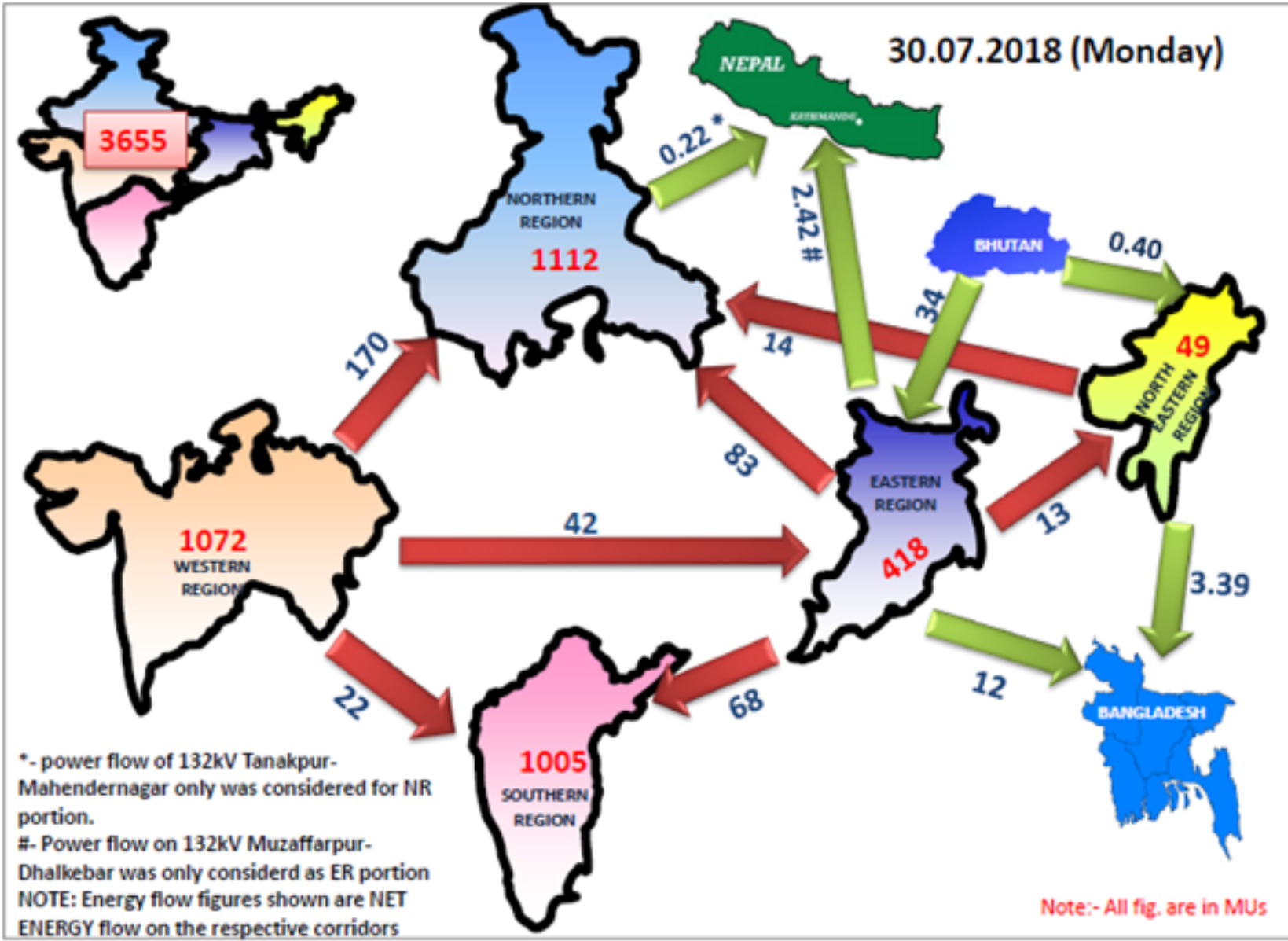

- Transfer Capability to be factored
- System Security
- Spatial distribution of generation
- Cheaper generation in WR
- Costly generation in NR & SR

Example

Thin Centralized Optimization Layer

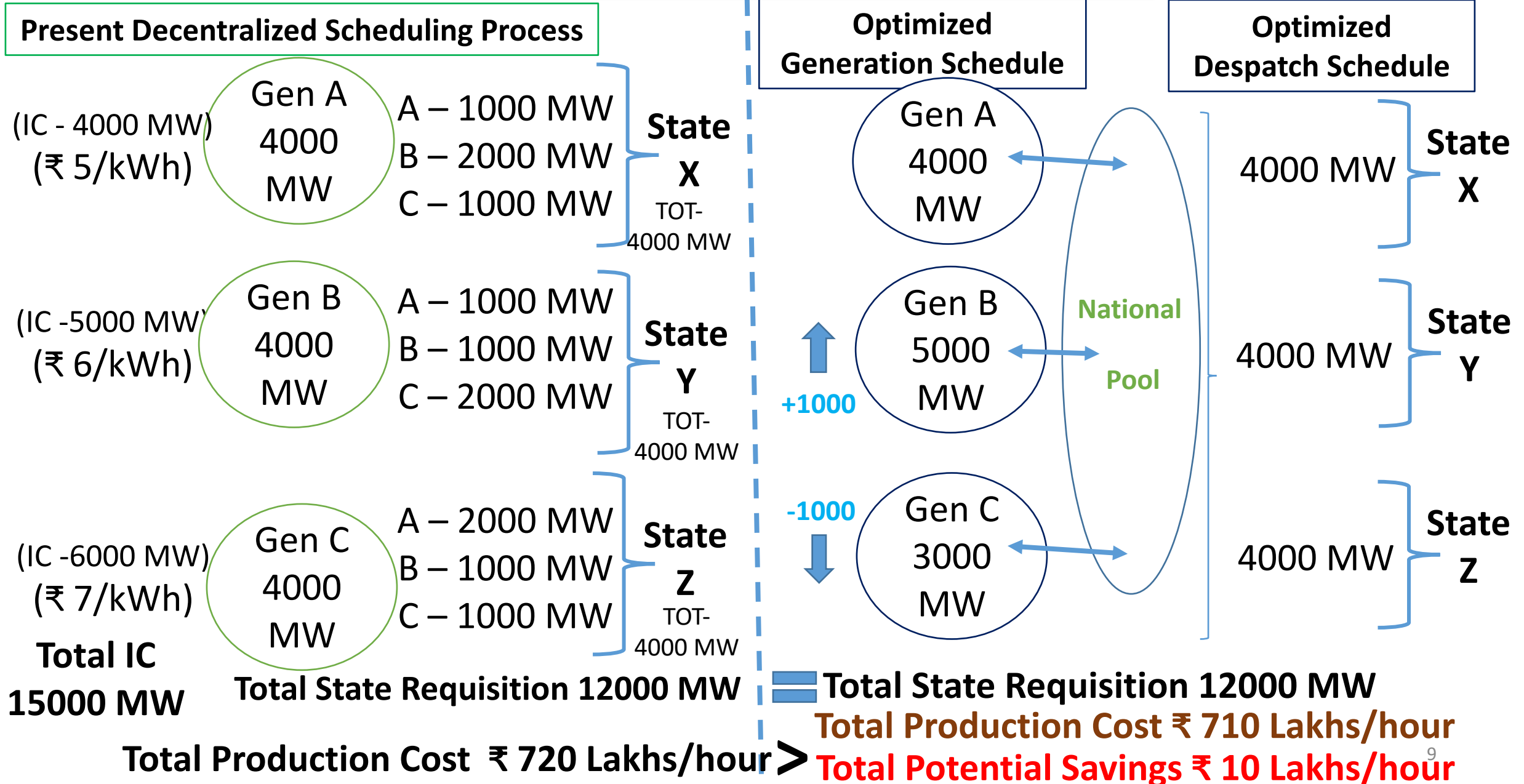

Economic Despatch - Mathematical Formulation

Objective Function

- Minimize Pan India ISGS Variable Cost

Subject to Constraints

- Meeting Total Requisition by States from ISGS
- Transmission Constraints (ATC)
- Technical Minimum of Plants
- Maximum Generation (DC-on-bar)
- Ramp up and down rate
- Factoring Spinning Reserves/Heat Rate

- Minimise $\sum_{i=1}^k C_i P_i$
 - k = total number of Plants
 - Where C_i is the variable per unit cost of the i^{th} Plant
 - P_i is the optimised scheduled power of the i^{th} Plant
- Subject to
 - $\sum_{i=1}^k P_i = \sum_{i=1}^k S_i$
 - $P_i \leq (\text{DC on bar})$
 - $P_i \geq P_{i,\text{min}}$
 - $P_{i,t} \leq P_{i,t-1} + \text{Ramp up rate}$
 - $P_{i,t} \geq P_{i,t-1} - \text{Ramp down rate}$
 - $\forall r \in R, \sum_r (P_{i,r} - S_{i,r}) \geq (\text{SCHIR}_r - \text{ATC}_r)$
 - S -is the scheduled power
 - t -represents current time of execution
 - R -represents each of the regions viz., North, East, West, South and North East
 - ATC -is the Available Transmission Capability of each region R
 - SCHIR -is the Scheduled Net Interchange of the region R
 - $P_{i,\text{min}}$ is the *technical minimum* for thermal power plants, considered 55% of DC on bar

Modelling for Economic Despatch – Process Flow

- RRAS implementation since April 2016
- The plant wise database for parameters were populated.
- Mathematical model was solved using the linear programming technique.
- General Algebraic Modeling System (GAMS) language and powerful commercial solvers like IBM CPLEX accessed through GAMS, was also used.
- Program executed every five minutes.
- All the input and output data archived.
- Data Analysis
- ~>50 man-months of efforts

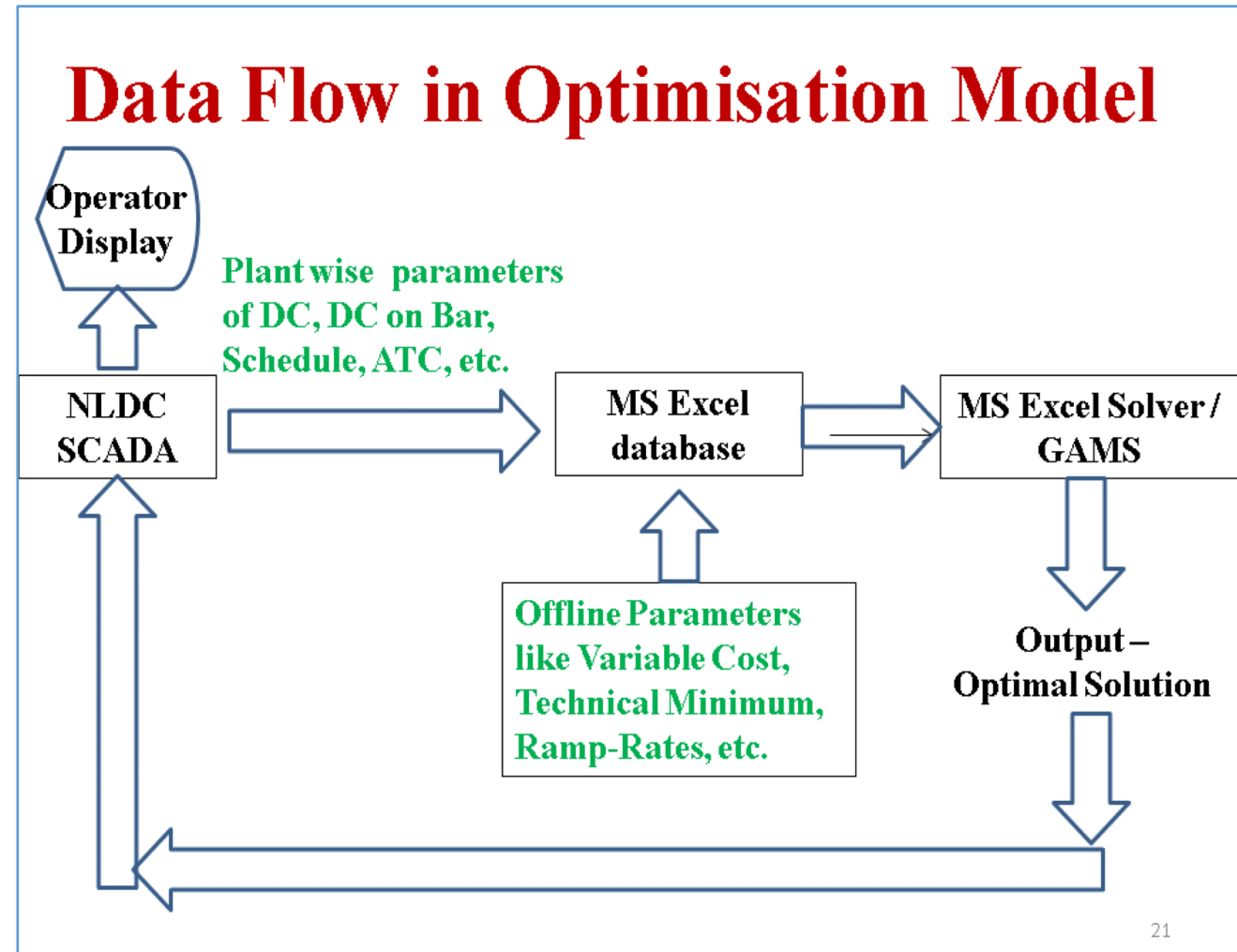

Sample Snapshots – Economic Despatch...1

S. NO.	TYPE	PLANT NAME	REG.	INSTALLED CAPACITY	TOTAL (MW)	DC ON BAR (MW),	SCHEDULE (MW),	VAR. COST P/UNIT	OPT. SCH. (MW)	OPT.SAV. (LAKHS)	OPT.SCH. DIFF.(MW)
25	T	NABINAGAR TPP	E	1x250	250	228	167	191	228	1	61
26	G	NTPC GANDHAR	W	3x144+ 1x255	657	180	180	205	180	0	0
27	G	ANTA GPS	N	3x89 + 1x153	419	0	0	224	0	0	0
28	T	RAMAGUNDAM TPS-STG.-III	S	1x500	500	471	259	227	471	5	212
29	T	RAMAGUNDAM TPS-STG.-I, II	S	3x200+3x500	2100	1800	1078	233	1800	17	722
30	T	KAHALGAON STG-II	E	3x500	1500	1414	1365	236	1414	1	49
31	G	NTPC KAWAS	W	4x106 + 2x116	656	255	255	236	255	0	0
32	T	FARAKKA STG 1 AND 2	E	3x200 + 2x500	1600	1100	936	243	1100	4	164
33	T	FARAKKA STG-III	E	1x500	500	300	259	244	300	1	41
34	T	SIMHADRI-NTPC STAGE-I	S	2x500	1000	948	521	244	948	10	427
35	T	SIMHADRI-NTPC STAGE-II	S	2x500	1000	948	521	245	825	7	303
36	T	KAHALGAON STG-I	E	4x210	840	740	618	246	407	-5	-211
37	T	MAUDA-II	W	1x660	660	375	343	259	206	-4	-137
38	T	UNCHAHAH TPS-III	N	1x210	210	191	191	261	105	-2	-86
39	T	UNCHAHAH TPS-I	N	2x210	420	382	382	261	210	-4	-172
40	T	UNCHAHAH TPS-II	N	2x210	420	382	382	261	210	-4	-172
41	G	AURAIYA GPS	N	4x111+ 2x109	663	0	0	270	0	0	0
42	L	NEYVELI TPS-II (EXPN.)-NLC	S	2x250	500	185	124	271	102	-1	-22
43	L	NEYVELI TPS-I (EXPN.)-NLC	S	2x210	420	385	210	271	212	0	1
44	T	UNCHAHAH TPS-IV	N	1x500	500	0	0	275	0	0	0
45	T	MAUDA	W	2x500	1000	575	518	276	316	-6	-202
46	L	NEYVELI-II (ISGS)- NLC	S	7x210	1470	1256	723	296	691	-1	-32
47	T	BONGAIGAON	NE	1x250	250	455	350	297	250	-3	-100
48	T	DADRI STG-2	N	2x490	980	464	357	302	255	-3	-101
49	T	INDIRA GANDHI TPS JHAJJAR	N	3x500	1500	1421	1097	303	782	-10	-316
50	T	VALLUR NTECL	S	3X500	1500	933	513	306	513	0	0
51	G	DADRI GPS	N	4x130+ 2x154	830	200	181	316	110	-2	-71
52	T	NTPC SOLAPUR	W	2x660	1320	270	270	327	149	-4	-122
53	T	NTPL	S	2x500	1000	938	516	317	516	0	0
54	T	DADRI STG-1	N	4x210	840	769	632	323	423	-7	-209
55	G	RGPP L IR	W		664	540	482	357	297	-7	-185

Database Covering Regulated
Tariff Generating Plants available
pan-India

Real time Data

Plant-wise and Region-wise
Operator Display

Change from Positive to Negative

System Marginal Cost

Sample Snapshots – Economic Despatch...2

PLANT NAME		TOTAL (MW)	DC (MW), A	DC ON BAR (MW), B	SCHEDULE (MW), C	ACTUAL (MW), D	COLD RESERVE E=(A-B)	ACTUAL MARGIN F=(B-D)	TOTAL URS G=(A-C)	SMP (Optimised)	POSSIBLE UP H=(B-C)	REGUALTN DOWN I=[C-(J*B)]	RRAS APPLIED (VAE)	DEVTN. K=(D-C)	OPT. SCH. (MW) (L)	OP.COST. (LAKHS) (M)	PRE.COST (LAKHS) (N)	OPT.SAV. (LAKHS) (Q)	OPT.SCH. DIFF.(MW) (O)
NORTHERN REGION	43 UNITS	11282	9063	7884	7297	7182	1179	748	1766	245	587	2960	0	-125	6170	114	147	-33	-1127
EASTERN REGION	19 UNITS	7010	5968	5968	5432	5399	0	569	536	245	536	3001	0	-79	5635	121	117	4	203
WESTERN REGION	54 UNITS	23907	20057	20057	19327	19521	0	-309	189	245	189	8593	0	-246	18725	275	294	-19	-603
SOUTHERN REGION	32 UNITS	12290	10398	10398	6646	6886	0	3373	3752	245	3752	1139	0	428	8272	198	160	38	1626
NORTH-EASTERN REGION	18 UNITS	671	744	744	639	625	0	119	105	245	105	230	0	-12	539	11	14	-3	-100
ALL INDIA	167 UNITS	55160	46230	45051	39341	39612	1179	4501	6349		5170	15923	0	-34	39341	719	732	-12	0

Regional Summary Display

Net Zero

Pan-India Optimization Results at a Glance

Interstate Thermal Generation Plants	57 Nos
Thermal Units	167 Nos
Total Installed Capacity	55160 MW
Range of Scheduled Power in a day	32000 MW – 46000 MW
Variable Cost range	₹ 1.12 -8.15 / kWh
Marginal Price range	₹ 2-4 / kWh
Weighted Average Variable Cost	₹ 1.89 / kWh
Average Production Cost per day	₹ 186 Crores / day
Average Potential Savings per day	₹ 2.4 Crores / day
Production Cost that can be saved	~ 1% to 2% (~1.3%)

System Marginal Cost and Demand

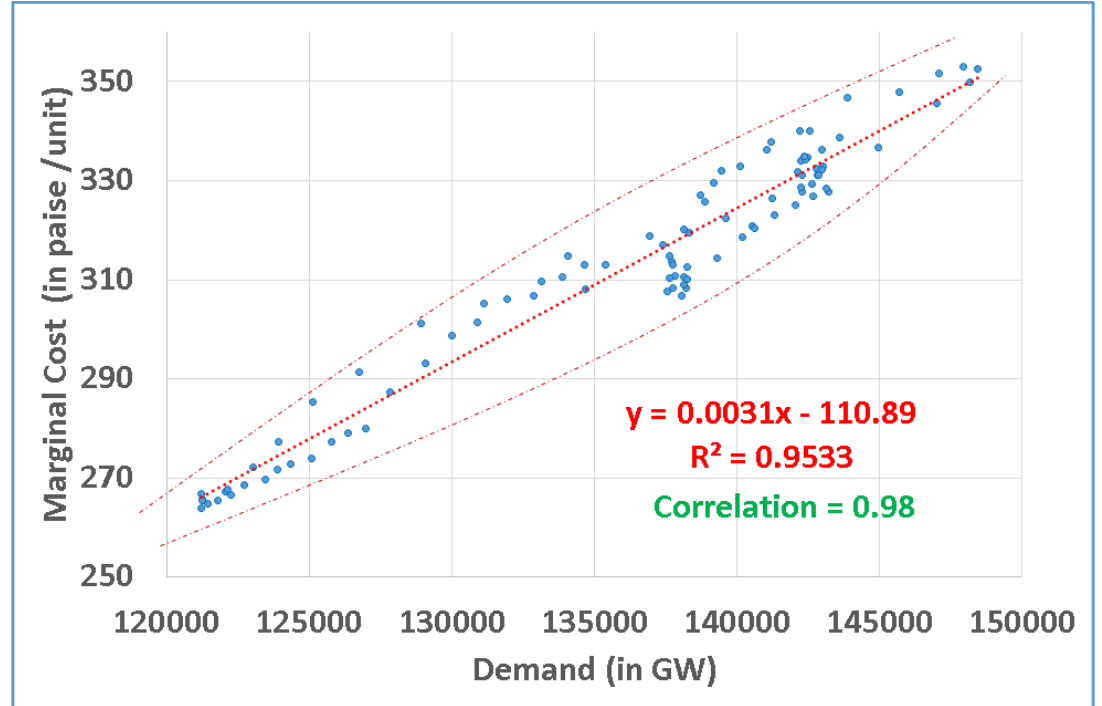
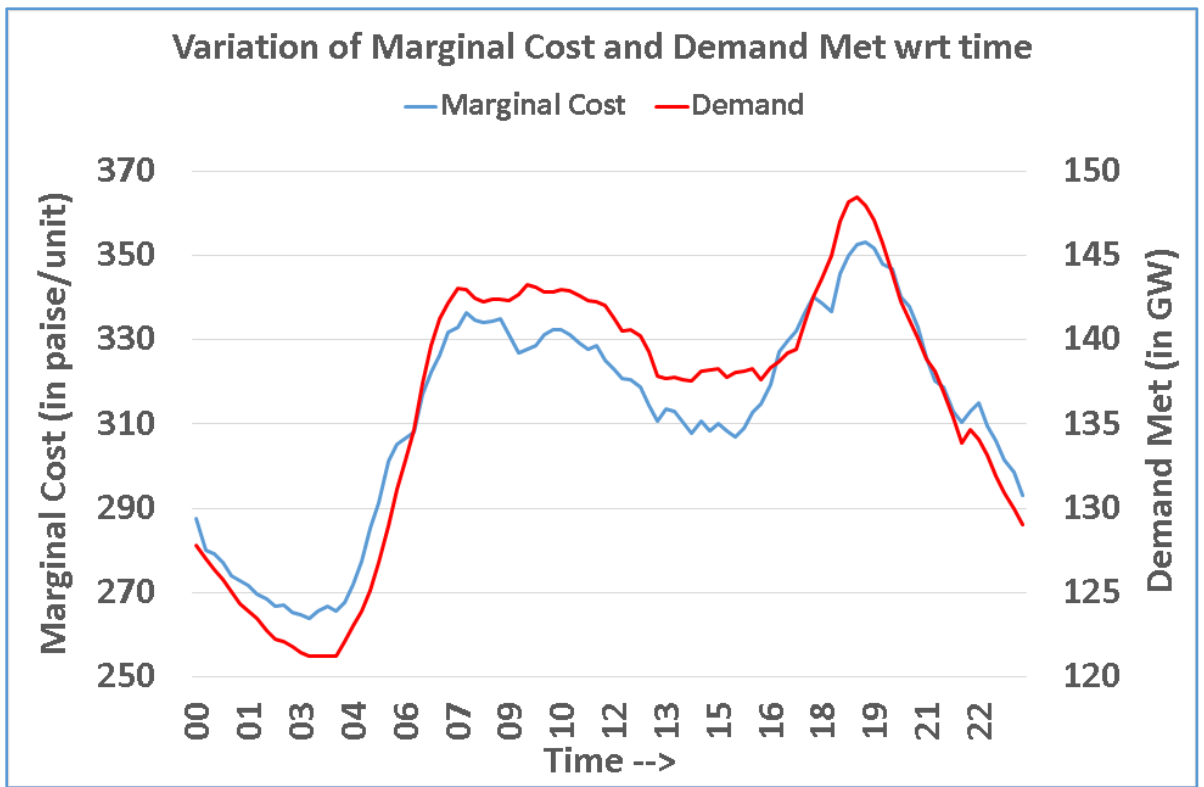

- During periods of high demand Production Cost and System Marginal Cost are high

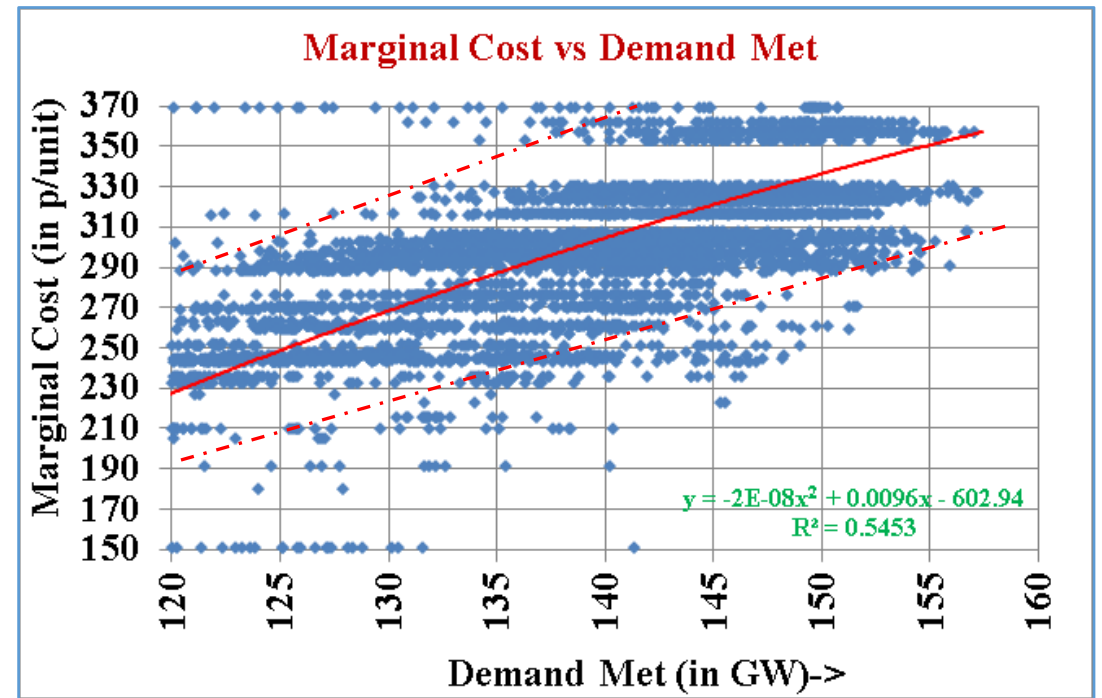

Potential Savings ...1

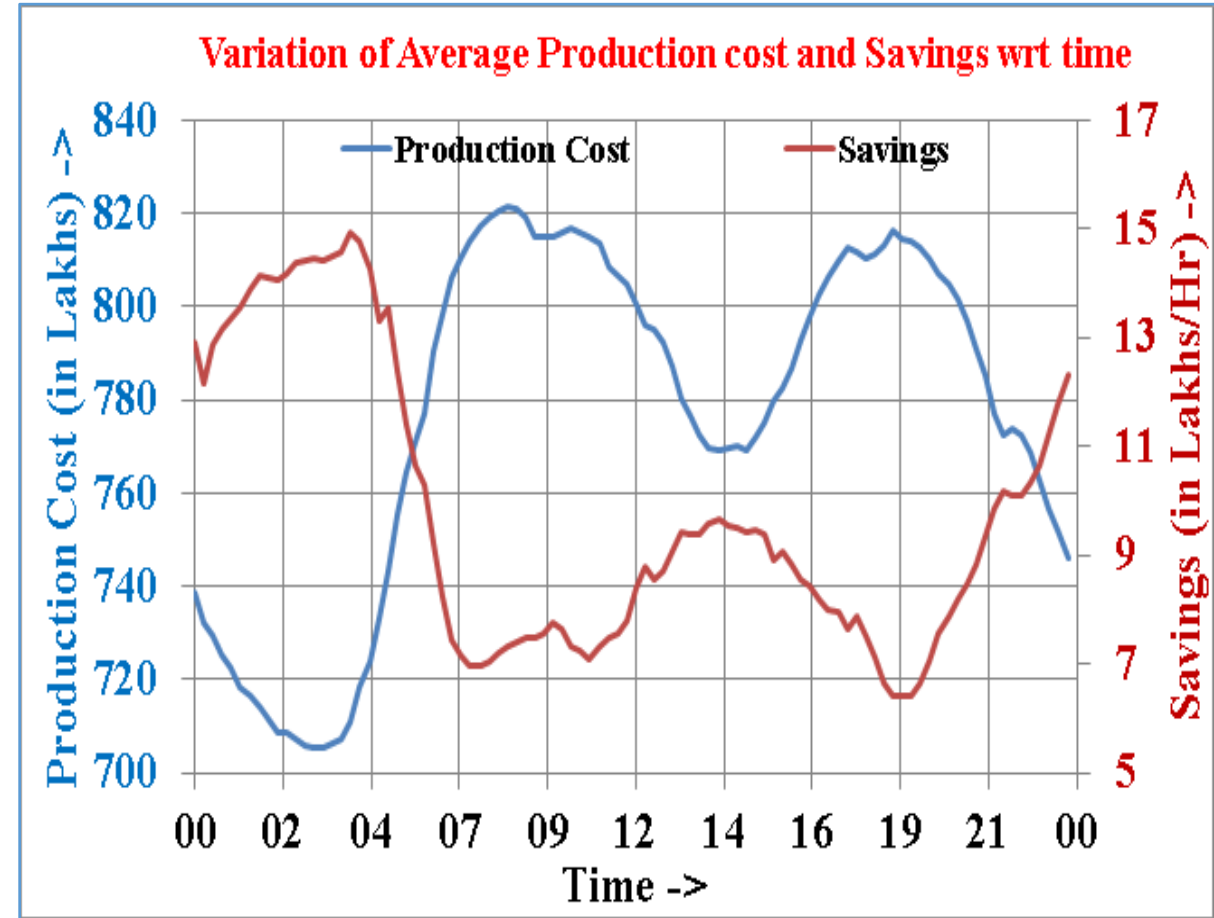
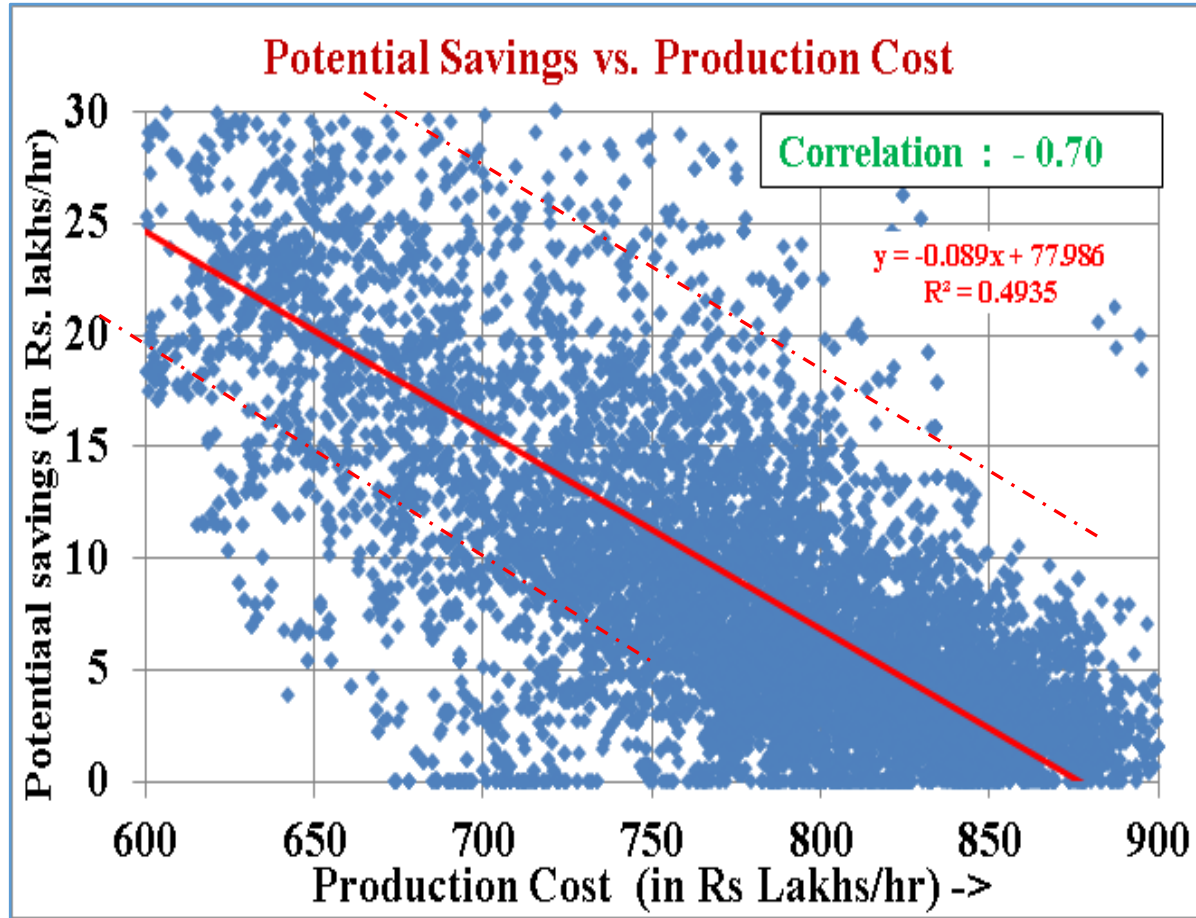

- Potential of savings inversely related to production cost
 - Possible Savings are the highest during off peak hours
- Compensation for increase in Net Heat Rate
 - Potential savings are slightly over estimated

Potential Savings ...2

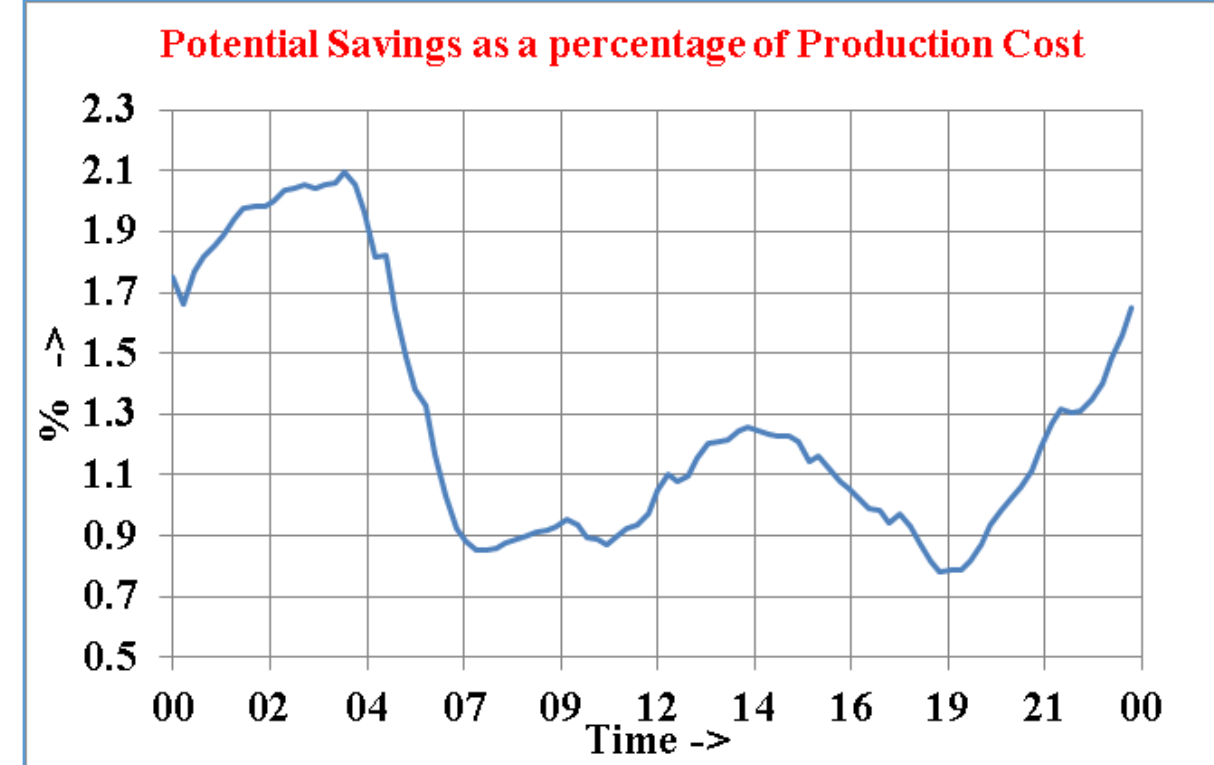
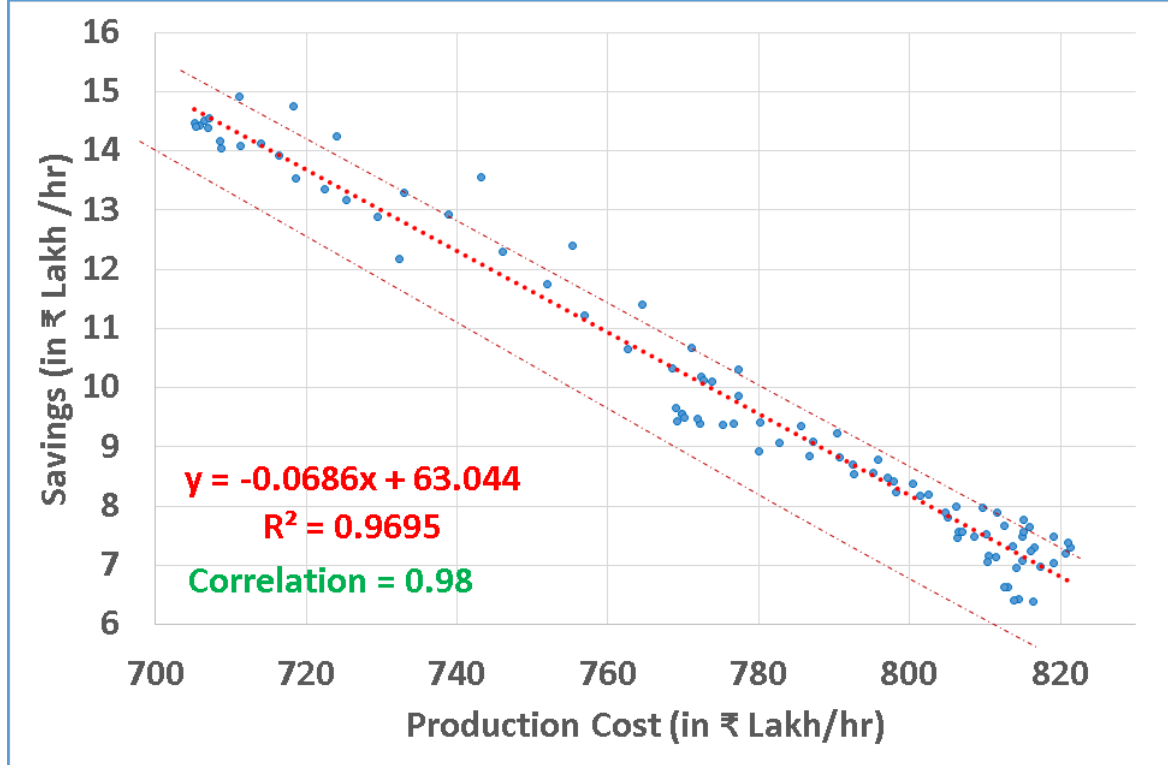

- Potential Savings is 1.3% of Production Cost
- Scope for incremental optimization and generating savings
 - Fragmented nature of allocations
 - Diversity
 - Decentralized scheduling
 - Transaction Cost

Potential Savings and Flexibility

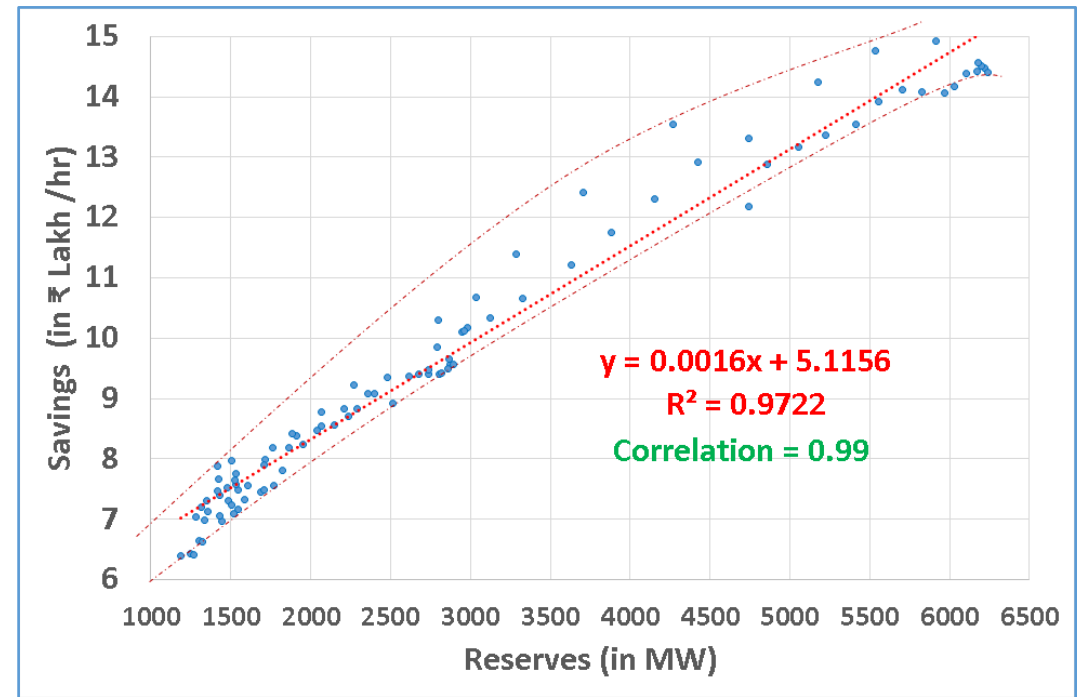
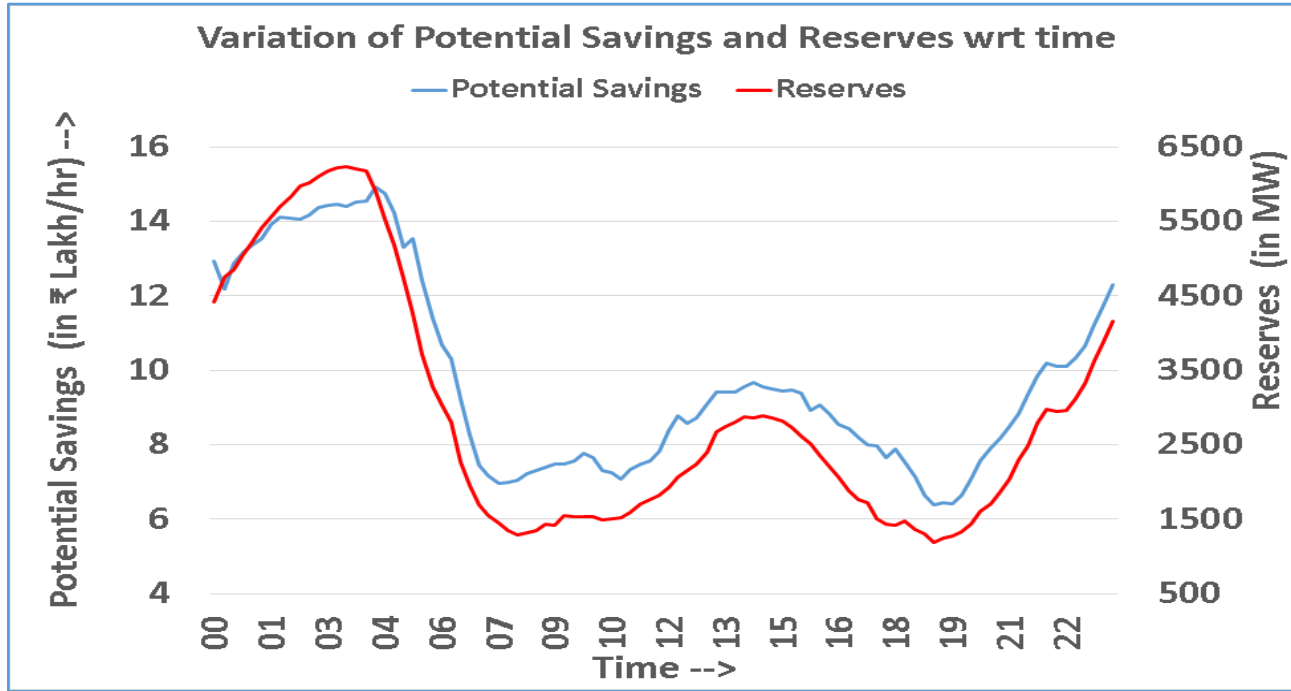

- Diversity in off peak and peak demand in the same day
- Some units were operated at technical minimum of 55%
- Flexible power plants provide higher savings potential

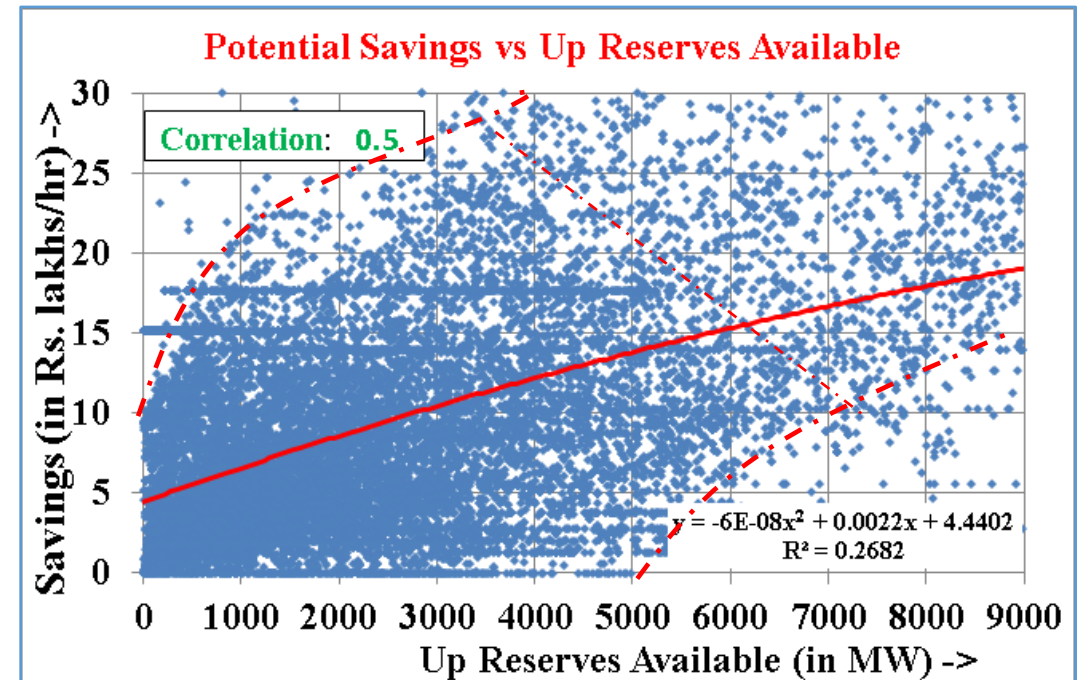

Spinning Reserve

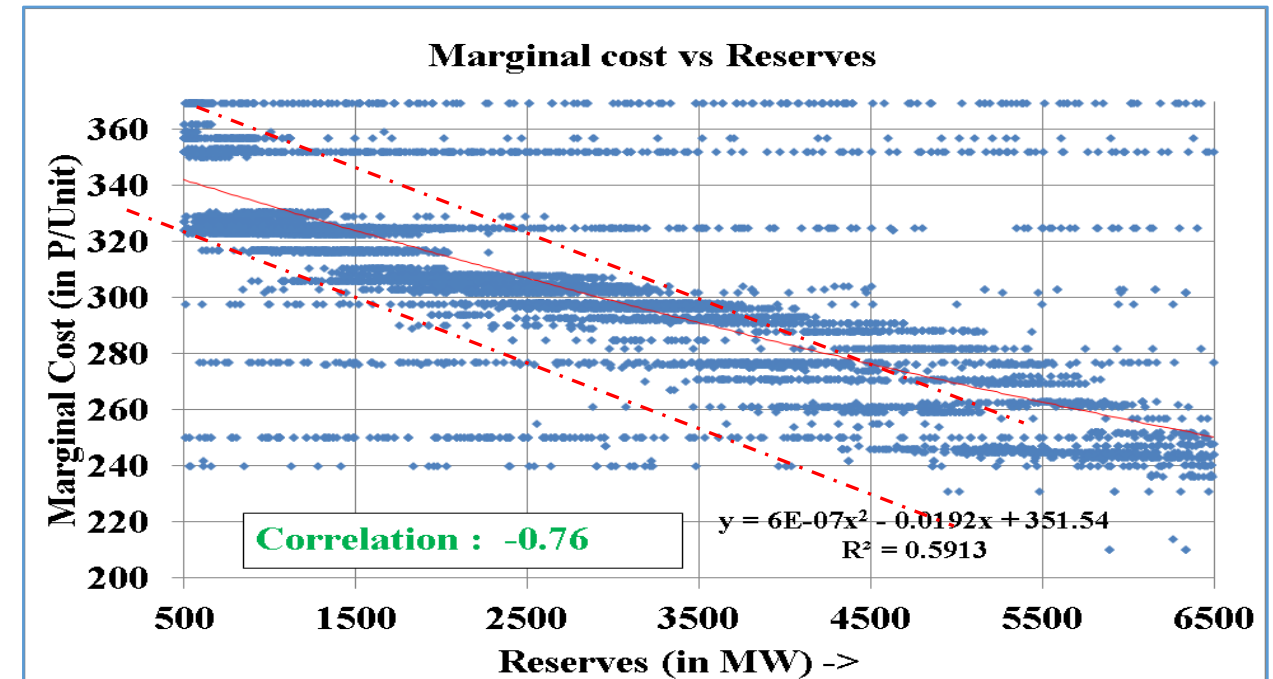
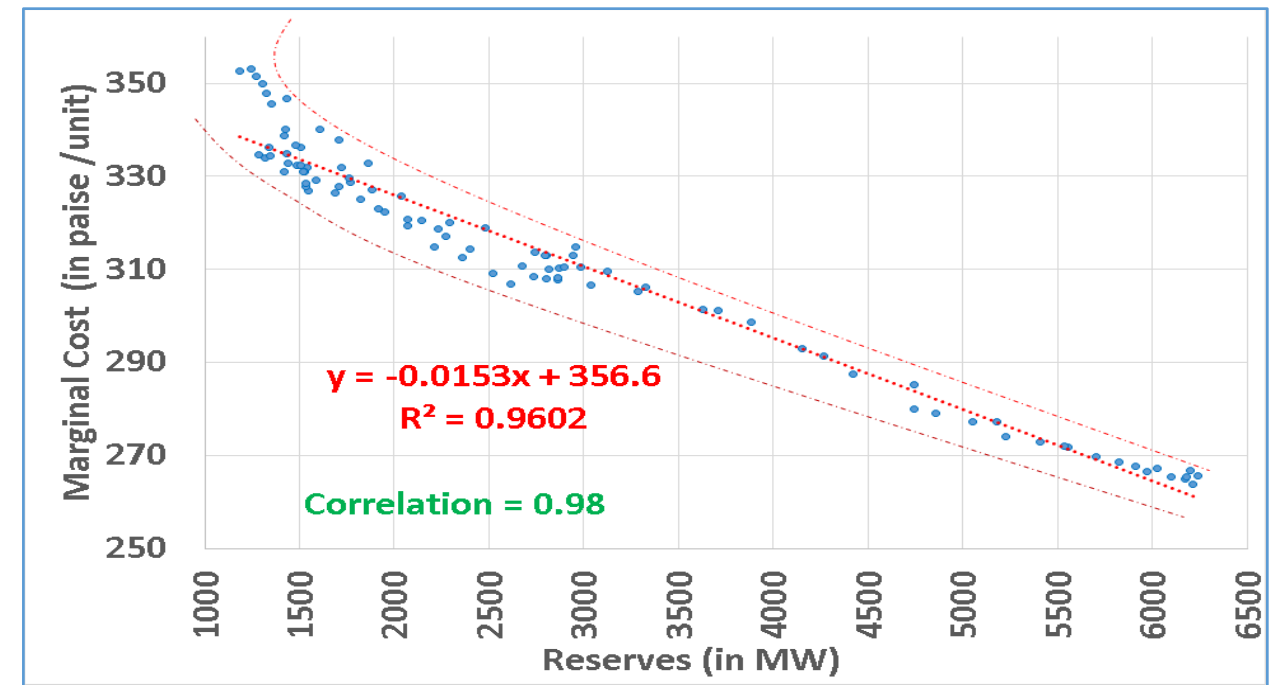
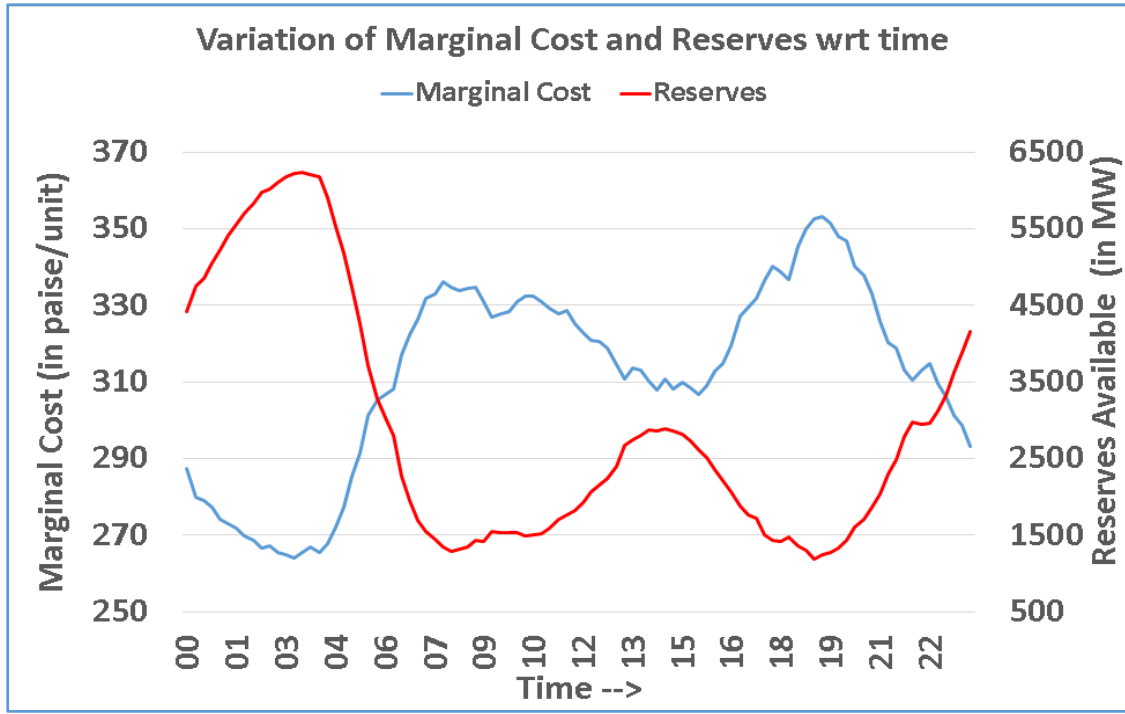

- System Marginal Cost inversely proportional to spinning reserve available
- System Marginal Cost during peak demand is high and Reserve is close to nil
- **Mandate needed for Reserves in Grid Code**

Spinning (Hot) Reserve and Non Spinning (Cold) Reserve

Block Wise Average Cold Reserves

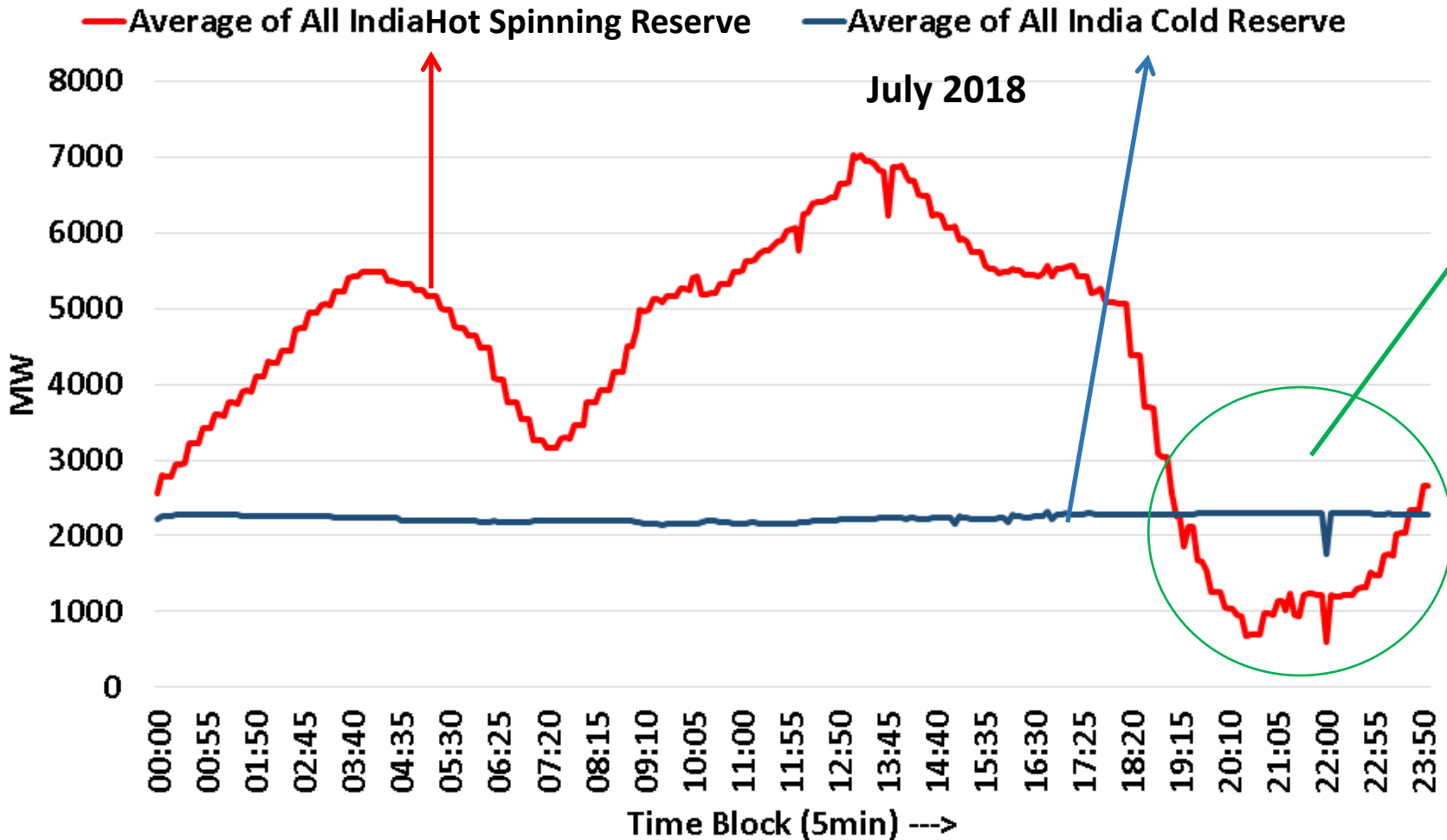

- Cold Reserve = DC-DC Conbar
- Time of necessity
- Cold Start up time
- Out of Merit generation
 - For majority of the day

Unit Ramp Rate effect on SCED

- Relatively Slow Ramping observed for some units
- **Declared Ramp should be Honoured**
- Effects of non performance might be cumulative
- Dadri demonstrated 3%

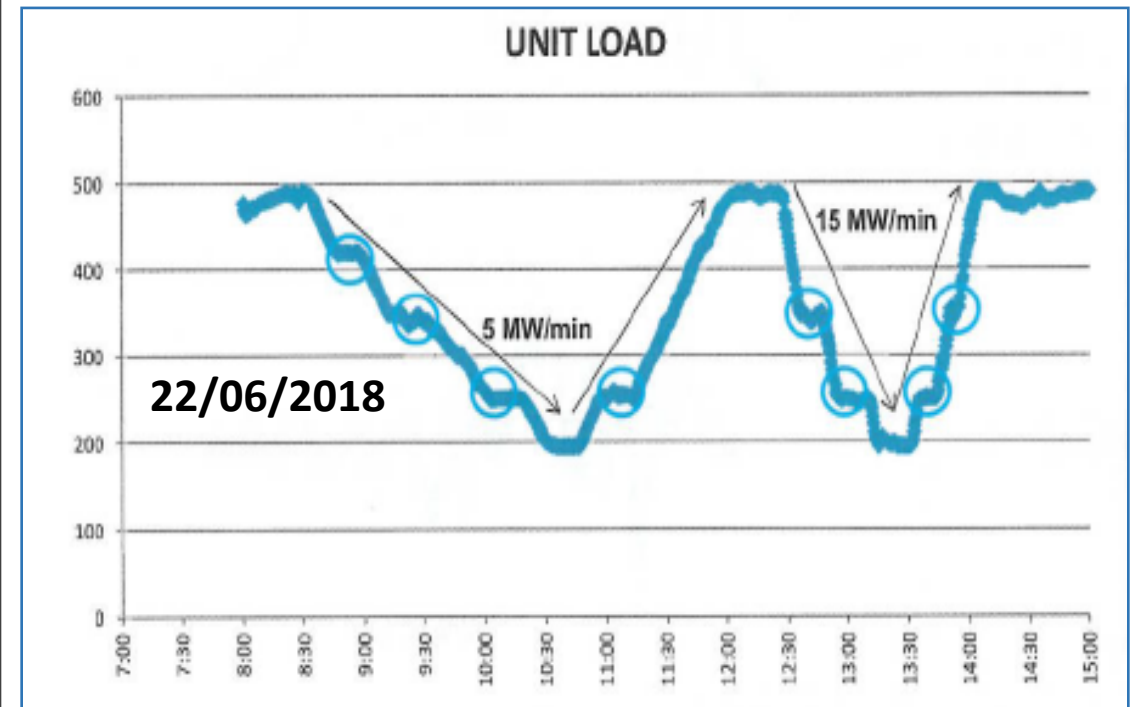
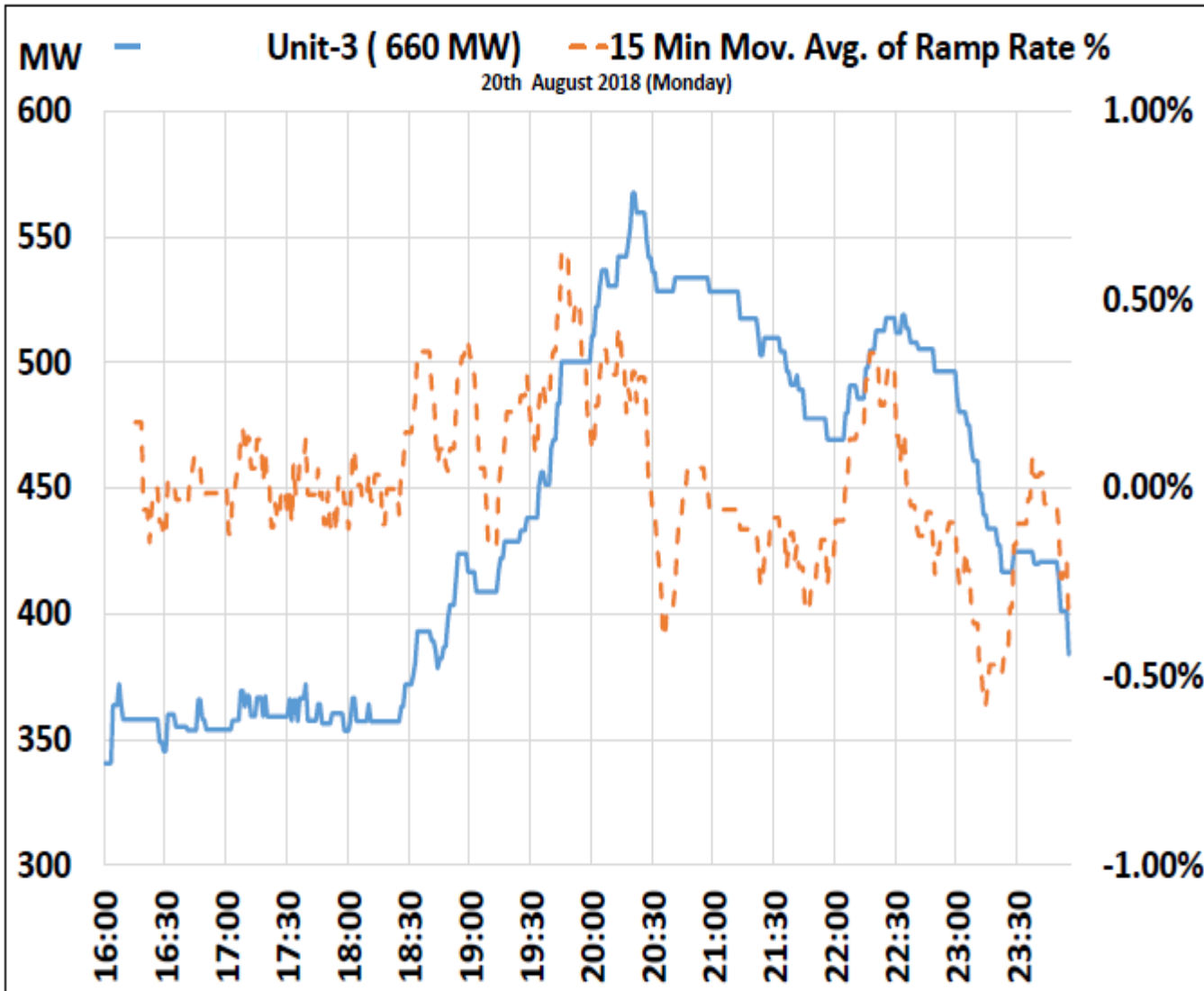

Action till Date

POSOCO report on 'Security Constrained Economic Despatch pan India' submitted to Hon'ble CERC
03 August 2018

POSOCO Consultation paper on "Security Constrained Economic Dispatch (SCED) of Inter-State Generating Stations pan India" submitted to Hon'ble CERC
12 September, 2018

<https://posoco.in/download/consultation-paper-on-security-constrained-economic-dispatch-of-isgs-pan-india/?wpdmdl=19708>

Hon'ble CERC Order Petition No. 02/SM/2019 (Suo-Motu)
31st January 2019

MoP scheme on 'Flexibility in Generation and scheduling of thermal power stations to reduce the cost of power to the consumer'
30 August, 2018

<https://posoco.in/download/posocos-observations-on-comments-on-the-consultation-paper-on-sced/?wpdmdl=21606>

Stakeholder Consultation
28 September 2018 - 20 November 2018
(10 Nos. Responses)

**Operationalization
01 April 2019**

Participation in the Pilot

All the thermal Inter State Generating Stations (ISGS) that are regional entities and whose tariff is determined or adopted by the Commission for their full capacity.

Sl No	RRAS Provider Name	Region	Installed Capacity (MW)	Fixed cost (Paisa/kWh)	Variable cost (Paisa/kWh)	Ramp Up (MW/Block)	Ramp Down (MW/Block)	Technical Minimum (MW)
1	AGTPP - Agartala*	AR	130	172.1	159.8	8	8	70
2	AGBPP - Kathalguri	AR	291	199.5	214.8	34	34	264
3	BongaonGTPP	AR	250	271.42	301.9	15	15	138
Total Installed Capacity			AR	671				
Source-NERPC- http://www.nerpc.nic.in/Ancillary%20service.php								
4	Talcher STPS - I	ER	1000	96.4	158.4	48	48	518
5	Nabinagar Thermal Power Project	ER	500	242.6	180	40	40	275
6	Barh TPS	ER	1320	186.5	215.9	90	90	684
7	Kahalgaoon STPS - II	ER	1500	109.8	220.1	113	113	778
8	Farakka STPS - I & II	ER	1600	83.5	224.9	120	120	823
9	Farakka STPS - III	ER	500	150.4	225.5	38	38	259
10	Kahalgaoon STPS - I	ER	840	106.5	230.2	90	90	421
11	MTPS Stage-II	ER	390	234.9	248.8	30	30	195
Total Installed Capacity			ER	7650				
Source-ERPC- http://erpc.gov.in/as-3-formats								
12	Singrauli STPS	NR	2000	65.7	137.1	135	197	1400
13	Rihand TPS Stage - II	NR	1000	71.2	138.4	100	150	518
14	Rihand TPS Stage - I	NR	1000	85.8	140.6	100	150	507
15	Rihand TPS Stage - III	NR	1000	145.6	141.5	100	150	518
16	Uncharhar TPS Stage - IV	NR	500	165.1	284.3	35	35	275
17	Uncharhar TPS Stage - I	NR	420	109.6	307.2	30	30	210
18	Uncharhar TPS Stage - II	NR	420	101.3	307.2	30	30	210
19	Uncharhar TPS Stage - III	NR	210	136.4	307.2	15	15	105
20	Auraiya Gas Power Project GF	NR	663	64.2	322.6	138	138	356
21	Anta Gas Power Project GF	NR	419	71.7	325	225	225	225
22	Dadri Gas Power Project GF	NR	830	58.2	333.7	50	50	445
23	Dadri TPS Stage - II	NR	980	145	341.4	100	100	509
24	Indra Gandhi STPS	NR	1500	162.8	345.7	150	150	782
25	Dadri TPS Stage - I	NR	840	98.7	364.1	80	80	422
26	Anta Gas Power Project RF	NR	419	71.7	885.7	225	225	225
27	Dadri Gas Power Project RF	NR	830	58.2	890.9	50	50	445
28	Auraiya Gas Power Project RF	NR	663	64.2	934.7	138	138	356
29	Dadri Gas Power Project LF	NR	830	58.2	1240	50	50	445
30	Auraiya Gas Power Project LF	NR	663	64.2	1255.3	138	138	356
31	Anta Gas Power Project LF	NR	419	71.7	1271.6	225	225	225
Total Installed Capacity			NR	11782				
Source-NRPC- http://www.nrpc.gov.in/comm/ancillaryservices.html								

32	Talcher STPS - II	SR	2000	72.1	157.4	150	150	1037
33	NLC TPS - I Exp	SR	420	102.5	236.3	36	45	211
34	NLC TPS - II Exp	SR	500	234.7	236.8	36	27	248
35	Ramagundam STPS - III	SR	500	77.6	251.1	50	50	259
36	NLC TPS - I	SR	630	80.5	255.7	54	68	312
37	NLC TPS - II	SR	840	83.4	255.7	72	90	416
38	Ramagundam STPS - I & II	SR	2100	73.2	257.4	210	210	1078
39	Simhadri STPS - I	SR	1000	95.1	277.4	100	100	521
40	Simhadri STPS - II	SR	1000	153.3	277.9	100	100	521
41	NTPL - Tuticorin TPS	SR	1000	156.2	305.4	75	75	516
42	NTECL - Vallur TPS	SR	1500	178.4	373.2	113	113	770
43	Kudgi STPS I	SR	2400	155.2	385.2	180	180	1244
Total Installed Capacity			SR	13890				
Source- http://www.srpc.kar.nic.in/html/all_uploads.html								
44	SIPAT TPS Stg-I	WR	1980	131.54	116	90	90	1026
45	SIPAT TPS Stg-II	WR	1000	124.87	120.3	69	69	518
46	Korba STPS STG (III)	WR	500	139.6	129.7	30	30	256
47	Korba STPS STG (I & II)	WR	2100	68.9	131.5	135	135	820
48	Sasan Power Ltd	WR	3960	17	131.7	180	180	2400
49	Vindhyachal-III	WR	1000	105.5	140.2	70	70	518
50	Vindhyachal-II	WR	1000	70.1	140.6	70	70	518
51	Vindhyachal-IV	WR	1000	158	140.6	70	70	518
52	Vindhyachal-V	WR	500	168.65	141.2	35	35	256
53	Vindhyachal-I	WR	1260	86.4	150.1	90	90	631
54	Costal Gujarat Power Ltd	WR	4150	90.31	179.65	150	150	2090
55	Ratnagiri Gas & Power Pvt Ltd GF	WR	663.54	130	249.0	300	300	354
56	Gandhar Gas Power Project GF	WR	657.39	105.7	258.9	293	293	354
57	Kawas Gas Power Project GF	WR	656.2	85.4	262.5	208	208	352
58	NTPC-SAIL Power Company Pvt. Ltd	WR	500	172.5	264.5	30	30	250
59	Mouda STPP Stage-I	WR	1000	189.4	277	70	70	518
60	Mouda STPP Stage-II	WR	1320	142.2	283.4	70	70	686
61	Gandhar Gas Power Project NAPM	WR	657.39	105.7	288.1	293	293	354
62	Kawas Gas Power Project NAPM	WR	656.2	85.4	288.6	208	208	352
63	Ratnagiri Gas & Power Pvt Ltd IR	WR	540	130	407.0	300	300	288
64	RGPP-L-Maharashtra	WR	68	130	407.0	300	300	36
65	RGPP-L-Others	WR	32	130	407.0	300	300	17
66	Solapur Super Thermal Power Project	WR	660	215.6	418.9	30	30	343
67	Ratnagiri Gas & Power Pvt Ltd RF	WR	1122	130	465.0	300	300	354
68	Gandhar Gas Power Project RF	WR	657.39	105.7	739.2	293	293	354
69	Kawas Gas Power Project RF	WR	656.2	85.4	747.5	208	208	352
70	Kawas Gas Power Project LF	WR	656.2	85.4	1115.5	208	208	352
Total Installed Capacity			WR	23907				
http://www.wrpc.gov.in/Commercial_rras_dat.asp?m=								
All India Total Installed Capacity				57901				

All thermal RRAS Providers would also participate in the SCED pilot.

The latest list of RRAS Providers is available at <https://posoco.in/download/rras-providers-rate-from-16th-jan19-to-15th-feb19/?wpdmdl=21301>

SCED Accounting & Settlement

SCED Energy Accounting

- To be incorporated by RPCs on weekly basis along with DSM RRAS, FRAS and AGC accounts
- SCED Schedules to be provided by NLDC through the RLDCs
- NLDC would indicate consolidated "National SCED Settlement Statement"
 - Schedules on account of SCED.
 - Payment and receipts to/from SCED Providers.

SCED Energy Settlement

- National Pool Account (SCED) to be operated by NLDC
- Settlement using variable charges declared under RRAS
- All payments shall flow from/to the National Pool Account (SCED)
 - For Increment in Scheduled Generation, SCED provider to be paid from the National Pool Account (SCED)
 - For Decrement in Scheduled Generation, SCED Provider to pay to National Pool Account (SCED)
- Compensation due to part load operation as certified by RPC in accordance with the provisions of IEGC to be factored
- No retrospective settlement
- Any deviation settled as per CERC DSM Regulation

Implementation Actions

- Detailed Procedures to be issued by NLDC
- Schedules of the States/beneficiaries would not be changed and the beneficiaries would continue to pay the charges for the scheduled energy directly to the generator as per the existing practice
- NLDC to open a separate bank account - “National Pool Account (SCED)”
 - Savings obtained through SCED after settlement of all accounts of SCED would be recorded and maintained in the “National Pool Account (SCED)” by the NLDC.
 - The sharing of benefits/savings has been accepted in principle by the Commission. However, methodology of sharing shall be decided after the results of the pilot and the extent of savings are available.
- Web Based Energy Scheduling Software
 - Batch processing of schedules
 - Schedule data interchanges between the RLDCs/NLDC, synching of data
 - Pre-processing & validation being sent to the SCED engine
 - Core optimization (SCED) engine – development, testing and validation
 - Output of SCED to be incorporated in the schedules
- Creation of a counterparty to SCED
- Augmentation of Communication infrastructure

Thank you

