



भारत सरकार Government of India

विद्युत मंत्रालय Ministry of Power

उत्तर पूर्वी क्षेत्रीय विद्युत समिति

North Eastern Regional Power Committee

एन ई आर पी सी कॉम्प्लेक्स, डोंग पारमाओ, लापालाङ, शिल्लोंग-७९३००६, मेघालय  
NERPC Complex, Dong Parmaw, Lapalang, Shillong - 793006, Meghalaya

Ph. No: 0364 - 2534039

Fax No: 0364 - 2534040

Website: www.nerpc.nic.in

No. NERPC/SE (O)/OCC/2019/ **1844-1881**

Dated: January 21, 2019

To,

1. Managing Director, AEGCL, Bijuli Bhawan, Guwahati – 781 001
2. Managing Director, APDCL, Bijuli Bhawan, Guwahati – 781 001
3. Managing Director, APGCL, Bijuli Bhawan, Guwahati – 781 001
4. Director (Generation), Me. PGCL, Lumjingshai, Short Round Road, Shillong – 793 001
5. Director (Distribution), Me. ECL, Lumjingshai, Short Round Road, Shillong – 793 001
6. Director(Transmission), Me. PTCL, Lumjingshai, Short Round Road, Shillong – 793 001
7. Managing Director, MSPDCL, Secure Office Bldg. Complex, South Block, Imphal – 795 001
8. Managing Director, MSPCL, Electricity Complex, Keishampat, Imphal – 795 001
9. Director (Tech.), TSECL, Banamalipur, Agartala -799 001.
10. Director (Generation), TPGCL, Banamalipur, Agartala -799 001.
11. Chief Engineer (WE Zone), Department of Power, Govt. of Arunachal Pradesh, Itanagar- 791111
12. Chief Engineer (EE Zone), Department of Power, Govt. of Arunachal Pradesh, Itanagar- 791111
13. Chief Engineer (TP&MZ), Department of Power, Govt. of Arunachal Pradesh, Itanagar- 791111
14. Engineer-in-Chief (P&E), Department of Power, Govt. of Mizoram, Aizawl – 796 001
15. Chief Engineer (P), Department of Power, Govt. of Nagaland, Kohima – 797 001
16. CGM, (LDC), SLDC Complex, AEGCL, Kahilipara, Guwahati-781 019
17. Group General Manager, NTPC, Bongaigoan Thermal Power Project, P.O. Salakati, Kokrajhar- 783369
18. ED, NERTS, PGCIL, Dongtiah-Lower Nongrah, Lapalang, Shillong -793 006
19. ED (O&M), NEEPCO Ltd., Brookland Compound, Lower New Colony, Shillong-793003
20. ED (Commercial), NEEPCO Ltd., Brookland Compound, Lower New Colony, Shillong-793003
21. ED (O&M), NHPC, NHPC Office Complex, Sector-33, Faridabad, Haryana-121003
22. Vice President (Plant), OTPC, Badarghat Complex, Agartala, Tripura - 799014
23. GM, NERLDC, Dongtiah, Lower Nongrah, Lapalang, Shillong -793 006
24. Member Secretary, ERPC, 14 Golf Club Road, Tollygunge, Kolkata-700033
25. Chief Engineer, GM Division, Central Electricity Authority, New Delhi – 110066
26. Chief Engineer (NPC), NRPC Complex, Katwaria Sarai, SJSS Marg., New Delhi - 110016

**Sub: Minutes of 152<sup>nd</sup> OCC Meeting.**

Sir/Madam,

Please find enclosed herewith the minutes of 152<sup>nd</sup> OCC Meeting held at Guwahati on the **11<sup>th</sup> January, 2019** for your kind information and necessary action. The minute is also available on the website of NERPC, [www.nerpc.nic.in](http://www.nerpc.nic.in).

Any comments/observations may kindly be communicated to NERPC Secretariat at the earliest.

**Encl: As above**

भवदीय / Yours faithfully,

बि. लिंगखोइ / B. Lyngkhoi

निदेशक □ Director/ SE

Copy to:

1. CGM, AEGCL, Bijuli Bhavan, Guwahati - 781001
2. CGM, APGCL, Bijuli Bhavan, Guwahati - 781001
3. CGM, DISCOM, Bijuli Bhavan, Guwahati - 781001
4. Head of SLDC, Me.ECL, Lumjingshai, Short Round Road, Umjarain, Shillong – 793 022
5. Head of SLDC, Department of Power, Govt. of Arunachal Pradesh, Itanagar- 791 111
6. Head of SLDC, Department of Power, Dimapur, Nagaland
7. Head of SLDC, Electricity Department, Govt. of Manipur, Keishampat, Imphal – 795 001
8. Head of SLDC, Department of Power, Govt. of Mizoram, Aizawl – 796 001
9. Head of SLDC, TSECL, Agartala – 799 001
10. Chief Engineer(Elect), Loktak HEP, Vidyut Vihar, Kom Keirap, Manipur- 795124
11. Addl. GM (EED), NTPC Ltd., Bongaigoan Thermal Power Project, P.O. Salakati, Kokrajhar- 783369
12. DGM (C&M), OTPC, 6th Floor, A-Wing, IFCI Tower -61, Nehru Place, New Delhi – 110019.



निदेशक □Director□E

North Eastern Regional Power Committee

**MINUTES OF THE 151<sup>st</sup> OPERATION COORDINATION**

**SUB-COMMITTEE MEETING OF NERPC**

**Date** : 11/01/2019 (Friday)  
**Time** : 10:00 hrs  
**Venue** : "Hotel Nandan", Guwahati.

The List of Participants in the 152<sup>nd</sup> OCC Meeting is attached at **Annexure - I**

Shri P.K. Mishra, Member Secretary, NERPC welcomed all the participants to the 152<sup>nd</sup> OCC meeting. He expressed satisfaction about large number of participation and thanked all the members for their enthusiastic participation. He wished all the participants a very happy new year ahead and requested that pending projects in NER should be taken up, right from the start of the year so that the region can strive forward.

Thereafter, Member Secretary requested Shri B. Lyngkhoi, Director (O&P) to take up the agenda for discussion.

**A. CONFIRMATION OF MINUTES**

**CONFIRMATION OF MINUTES OF 151<sup>st</sup> MEETING OF OPERATION SUB-COMMITTEE OF NERPC.**

The minutes of 151<sup>st</sup> meeting of Operation Sub-committee held on 14<sup>th</sup> December, 2018 at Guwahati were circulated vide letter No. NERPC/SE (O)/OCC/2016/4556-4591 dated 26<sup>th</sup> December, 2018.

*The Sub-committee confirmed the minutes of 151<sup>st</sup> OCCM of NERPC as no comments/observations were received from the constituents.*

**ITEMS FOR DISCUSSION**

**B.1. ACTION TAKEN:**

**1. IMPLEMENTATION OF PROJECTS FUNDED FROM PSDF:**

The status as informed in 152<sup>nd</sup> OCC:

| State       | R&U scheme  | ADMS  | Capacitor Installation                                   | SAMAST **                     | Line Differential Protection                           |
|-------------|---|---|--|-------------------------------|--|
| Ar. Pradesh | Pkg-I: Tender floated.<br>Pkg-II: Tender by Jan'19.                               | Revised DPR submitted                           | -  | TESG queries submitted.       | -  |
| Nagaland    | Pack-A: Completed<br>Pack-B: Dec'18<br>Pack-C: Dec'18<br>Pack-D: Completed.       | Revised DPR submitted                           | To re-submit proposal to NERPC for Study.                | TESG queries to be submitted. | Lines identified. Under DPR preparation stage.         |
| Mizoram     | LOAs issued. Completion by Mar'19.  | Revised DPR submitted                           | To re-submit proposal to NERPC for Study.                | TESG queries submitted.       | Lines not yet identified. To be taken up in Sub-group. |
| Manipur     | LOAs issued. Completion by Nov'18.  | Revised DPR submitted                           | Submitted to NERPC for Study before sending to NPC/NLDC. | TESG queries to be submitted. | Lines not yet identified. To be taken up in Sub-group. |
| Tripura     | 90% completed. Remaining by Feb'19  | Revised DPR submitted                           | To submit proposal to NERPC for Study.                   | TESG queries submitted.       | Lines not yet identified. To be taken up in Sub-group. |
| Assam       | Substation auxiliary and diagnostics tools - Tendering in process. LOA by Dec'18. | Revised DPR submitted                           | -  | TESG queries submitted.       | Lines identified. Under DPR preparation stage.         |
| Meghalaya   | MePTCL LOA issued, 95% completed. Remaining LOAs by                               | Revised DPR submitted. Query referred to DISCOM | -  | TESG queries submitted.       | DPR already submitted and                              |

|  |  |  |  |  |                   |
|--|--|--|--|--|-------------------|
|  | Feb'19. Commissioning works 60% completed, Total balance works by Jun'19. MePGCL – Erection complete by Mar'19 |  |  |  | awaited approval. |
|--|--|--|--|--|-------------------|

**Deliberation of the sub-Committee:**

Director, NERPC stated that ADMS project has been approved for common tendering in 19th NERPC. Since group for preparation of the Tender documents has already been prepared, he informed that a meeting of the group is scheduled on 24.01.2019 at NERPC Shillong. He requested all the members to attend the above meeting.

Members noted that R&U works for most states are under advance stage and many issues viz. DR&EL standardization, relay coordination, database preparation under PDMS etc. are to be coordinated. Hence, the progress is to be monitored station-wise. All the utilities were requested to submit station-wise status to NERPC & NERLDC.

Director, NERPC once again reiterated that OPGW and associated equipments for LDP would be adjusted under NERPSIP. He requested all the utilities (except MePTCL) to prepare and submit DPR within 10 days. Further he requested NERTS and MePTCL to extend necessary support for preparation of the said DPR.

***The Sub-Committee noted as above.***

***Action: All state utilities/NERPC.***

**2. Outage of Important Grid Elements:**

| Name of the Element                                       | Name of Utility | Status as informed in 152 <sup>nd</sup> OCC   |
|---|-----------------|---|
| 63MVAR Reactor at Byrnihat to replace with 80MVAR Reactor | MePTCL          | 1 <sup>st</sup> NERSCT MoM to be recorded. MePTCL may initiate preparation of bid documents etc for the tendering process. MePTCL requested PGCIL to share the bid documents for reactor to which PGCIL agreed. |

|  |       |  |
|--|-------|--|
| Outage of 420kV 80MVAR L/R for 400kV Bongaigaon-NSLG-I at Bongaigaon - (out since 04.07.18)  | NERTS | By January, 2019   |
| 132kV Dimapur - Imphal (out since 25.07.18)  | NERTS | By March, 2019**   |
| 63 MVAR B/R-4 at 400kV Biswanath-Chariali(out since 27.04.18)  | NERTS | Charged on 01.01.19  |
| 132 kV, 20MVAR Bus Reactor at Roing out of service since 08:00 Hrs of 16.08.18 (Shutdown approved till 1600 Hrs of 31st August'18) | NERTS | Charged on 22.12.18  |
| 220kV Sonabil-Samaguri-I   | AEGCL | RCE to be prepared due to observation of additional phase conductor snap. By Mar'19  |
| 420kV 80 MVAR Bus Reactor at 400 kV Imphal S/S( out since 21:05 Hrs of 25.12.18)   | NERTS | Tripped due to collection of fault gas in Bucholz. Internal inspection to be carried out, for which expert of OEM M/S CGL has arrived at site on 09.01.19. By 21.01.19 |
| 420kV 63 MVAR Line Reactor at 400 kV Bongaigaon S/S for 400kV Bongaigaon- Azara( out since Nov'18)                                 | NERTS | Spare reactor diverted from Balipara. By Jan'19  |

\*\* NERTS informed the following w.r.t. restoration of 132kV Dimapur-Imphal.

Work is in progress for diversion of 35 Locations to facilitate four-lanning of highway by NHIDCL. The existing line section has been dismantled at the insistence of NHIDCL and Govt. of Nagaland. Delay in construction of the new diverted sections is attributable to:

- (i) Severe ROW issues, that could be partially resolved towards the end of Nov'18 and work could be started.
- (ii) Clearance from ICAR (as the new line sections traverse through their plantation area) obtained in Nov'18.

Target completion: 31.03.19. However, all-out effort is being made to restore it earlier.

**The Sub-Committee noted as above.**

**Action: All concerned utilities & NERPC.**

**DIFFERENCE IN ACTUALS VS LGBR:****Energy Requirement:**

| Name of State | Aug 18 (actual) | Aug 18 (LGBR) | Sep 18 (actual) | Sep 18 (LGBR) | Oct 18 (actual) | Oct 18 (LGBR) | Nov 18 (actual) | Nov 18 (LGBR) |
|---------------|-----------------|---------------|-----------------|---------------|-----------------|---------------|-----------------|---------------|
| Ar. Pradesh   | 76.34           | 77.02         | 74.16           | 71.19         | 70.06           | 77.25         | 67.34           | 77.97         |
| Assam         | 1039.01         | 970.21        | 950.19          | 934.64        | 815.67          | 885.83        | 707.55          | 707.17        |
| Manipur       | 70.53           | 76.98         | 69.88           | 69.64         | 75.80           | 75.56         | 81.80           | 78.59         |
| Meghalaya     | 162.17          | 159.00        | 150.14          | 164.00        | 144.61          | 166.00        | 163.83          | 169.00        |
| Mizoram       | 58.96           | 44.80         | 58.04           | 39.37         | 70.64           | 44.19         | 67.71           | 47.06         |
| Nagaland      | 80.88           | 79.25         | 80.49           | 76.88         | 74.27           | 69.66         | 61.04           | 64.67         |
| Tripura       | 179.61          | 127.98        | 192.00          | 125.18        | 187.38          | 132.09        | 164.71          | 98.49         |

**Energy Availability:**

| Name of State | Aug 18 (actual) | Aug 18 (LGBR) | Sep 18 (actual) | Sep 18 (LGBR) | Oct 18 (actual) | Oct 18 (LGBR) | Nov 18 (actual) | Nov 18 (LGBR) |
|---------------|-----------------|---------------|-----------------|---------------|-----------------|---------------|-----------------|---------------|
| Ar. Pradesh   | 81.81           | 96.23         | 81.12           | 82.62         | 67.90           | 77.45         | 64.46           | 63.39         |
| Assam         | 991.95          | 967.37        | 987.64          | 859.96        | 772.79          | 898.78        | 747.84          | 795.50        |
| Manipur       | 109.25          | 126.69        | 177.79          | 110.48        | 105.39          | 117.42        | 85.54           | 106.01        |
| Meghalaya     | 285.36          | 322.71        | 276.17          | 308.96        | 200.13          | 274.43        | 175.54          | 206.71        |
| Mizoram       | 92.74           | 99.89         | 111.76          | 89.77         | 106.29          | 83.22         | 89.63           | 69.34         |
| Nagaland      | 84.88           | 99.50         | 81.24           | 87.96         | 68.17           | 88.06         | 53.51           | 72.04         |
| Tripura       | 312.05          | 294.40        | 309.44          | 268.15        | 342.04          | 300.01        | 332.36          | 272.69        |

**Demand:**

| Name of State | Aug 18 (actual) | Aug 18 (LGBR) | Sep 18 (actual) | Sep 18 (LGBR) | Oct 18 (actual) | Oct 18 (LGBR) | Nov 18 (actual) | Nov 18 (LGBR) |
|---------------|-----------------|---------------|-----------------|---------------|-----------------|---------------|-----------------|---------------|
| Ar. Pradesh   | 135.88          | 148           | 131.92          | 143           | 129.08          | 146.00        | 127.77          | 145.00        |
| Assam         | 1833.85         | 1752.66       | 1865.26         | 1787.60       | 1785.42         | 1840.56       | 1546.54         | 1558.56       |
| Manipur       | 177.32          | 173.10        | 184.39          | 168.04        | 187.28          | 175.61        | 189.23          | 182.53        |
| Meghalaya     | 325.43          | 314.92        | 317.42          | 328.18        | 336.23          | 320.58        | 352.42          | 342.37        |
| Mizoram       | 99.09           | 92.62         | 95.47           | 95.23         | 99.18           | 96.76         | 102.12          | 104.38        |
| Nagaland      | 134.32          | 139.63        | 142.07          | 148.77        | 133.77          | 138.05        | 139.00          | 133.50        |
| Tripura       | 291.86          | 327.32        | 296.01          | 359.46        | 269.32          | 312.39        | 258.54          | 278.62        |

**Deliberation of the sub-Committee:**

Member Secretary, NERPC stated that the disparities in actual vs LGBR should be taken into account while submitting the LGBR data for 2019-20.

**The Sub-committee noted as above.**

**Action: All SLDCs.**

**B.2. OPERATIONAL PERFORMANCE AND GRID DISCIPLINE DURING OCTOBER, 2018**

As per the data made available by NERLDC, the grid performance parameters for October, 2018 are given below:

**NER PERFORMANCE DURING OCTOBER, 2018**

| States        | Energy Met (MU) |                | w.r.t. Nov,18<br>% inc (+)<br>/dec (-) | Energy Reqr. (MU) |                | w.r.t. Nov,18<br>% inc (+)<br>/dec (-) | % inc (+)<br>/dec (-) of<br>energy reqr<br>vs met. In<br>Dec,18 |
|---------------|-----------------|----------------|--|-------------------|----------------|--|---|
|               | Dec-18          | Nov-18         |  | Dec-18            | Nov-18         |  |   |
| Ar. Pradesh   | 66.39           | 61.92          | 7.22                                   | 66.92             | 62.61          | 6.88                                   | -0.79   |
| Assam         | 717.65          | 694.25         | 3.37                                   | 731.54            | 710.63         | 2.94                                   | -1.90   |
| Manipur       | 82.72           | 71.22          | 16.15                                  | 83.20             | 72.27          | 15.12                                  | -0.58   |
| Meghalaya     | 194.31          | 162.38         | 19.66                                  | 194.31            | 162.38         | 19.66                                  | 0.00  |
| Mizoram       | 61.52           | 57.08          | 7.78                                   | 61.82             | 57.73          | 7.08                                   | -0.49   |
| Nagaland      | 64.05           | 55.40          | 15.61                                  | 72.39             | 63.74          | 13.57                                  | -11.52  |
| Tripura       | 111.63          | 112.05         | -0.37                                  | 111.84            | 113.16         | -1.17                                  | -0.19   |
| <b>Region</b> | <b>1298.27</b>  | <b>1214.30</b> | <b>6.92</b>                            | <b>1322.02</b>    | <b>1242.52</b> | <b>6.40</b>                            | <b>-1.80</b>  |

| States        | Demand Met (MW) |             | w.r.t. Sep,18<br>% inc (+)<br>/dec (-) | Demand in (MW) |             | w.r.t. Nov,18<br>% inc (+)<br>/dec (-) | % inc (+)<br>/dec (-) of<br>energy reqr<br>vs met. In<br>Dec,18 |
|---------------|-----------------|-------------|--|----------------|-------------|--|---|
|               | Dec-18          | Nov-18      |  | Dec-18         | Nov-18      |  |   |
| Ar. Pradesh   | 131             | 128         | 2.34                                   | 138            | 138         | 0.00                                   | -5.07   |
| Assam         | 1418            | 1525        | -7.02                                  | 1440           | 1547        | -6.92                                  | -1.53   |
| Manipur       | 211             | 189         | 11.64                                  | 214            | 189         | 13.23                                  | -1.40   |
| Meghalaya     | 366             | 352         | 3.98                                   | 365            | 352         | 3.69                                   | 0.27  |
| Mizoram       | 111             | 102         | 8.82                                   | 112            | 102         | 9.80                                   | -0.89   |
| Nagaland      | 133             | 135         | -1.48                                  | 135            | 139         | -2.88                                  | -1.48   |
| Tripura       | 228             | 258         | -11.63                                 | 240            | 259         | -7.34                                  | -5.00   |
| <b>Region</b> | <b>2511</b>     | <b>2620</b> | <b>-4.16</b>                           | <b>2541</b>    | <b>2672</b> | <b>-4.90</b>                           | <b>-1.18</b>  |

**REGIONAL GENERATION & INTER-REGIONAL EXCHANGE IN MU**

| Month---->                              | Dec-18        | Nov-18        |
|---|---------------|---------------|
| Total Generation in NER (Gross)         | 1342.003      | 1355.751      |
| Total Central Sector Generation (Gross) | 1016.068      | 1023.114      |
| Total State Sector Generation (Gross)   | 325.935       | 332.637       |
| <b>Inter-Regional Energy Exchange</b>   |               |               |
| (a) NER-ER                              | <b>246.21</b> | <b>0.00</b>   |
| (b) ER-NER                              | <b>99.54</b>  | <b>358.23</b> |
| (c)NER-NR                               | <b>76.18</b>  | <b>365.86</b> |
| (d)NR-NER                               | <b>275.56</b> | <b>0.00</b>   |
| © Net Import                            | 52.71         | -7.63         |

**AVERAGE FREQUENCY (Hz)**

| Month---->               | Dec-18    | Nov-18    |
|--------------------------|-----------|-----------|
|                          | % of Time | % of Time |
| Below 49.9 Hz            | 12.60     | 10.01     |
| Between 49.9 to 50.05 Hz | 76.96     | 80.54     |
| Above 50.05 Hz           | 10.43     | 9.45      |
| Average                  | 49.98     | 48.31     |
| Maximum                  | 50.25     | 50.25     |
| Minimum                  | 49.67     | 49.69     |

**Deliberation of the sub-Committee:**

NERLDC gave a presentation on the grid performance for the month of December'18. NERLDC also highlighted that Daily, Weekly and Monthly Voltage Deviation Report,

Frequency Deviation Report and System Reliability Report for December'18 was already mailed to all the constituents for necessary actions. Further, it was informed that members may access these reports from NERLDC website under the tab CERC KPI Reports. NERLDC informed the forum about the number of lines kept open on high voltage. NERLDC again requested for early restoration of reactors which are under long outage and commissioning of new reactors at the earliest as mentioned in Sl. No. B.1.2 and C.1 and support from Generator to control voltage so that it does not require to open lines for maintaining voltage profile within IEGC band.

Director, NERPC informed that Energy Requirement for Mizoram has increased by over 100% vis-a-vis previous year (Eg. 67.71-Nov'18; 33.65-Nov'17). He enquired the reasons thereof.

Sr.EE, P&ED Mizoram informed the following:

- Tuirial HEP has not been included in Scheduling of NER
- Very unpredictable generation from Tuirial HEP.
- Even though DC is given, sometimes 2 days prior, actual generation varies.
- These results in sustained underdrawal from the grid for Mizoram.

***The Sub-Committee noted as above.***

**ITEMS FOR DISCUSSION**

**C. OLD ITEMS**

**1. Status of Generating Units, Transmission Lines in NER:**

During 152<sup>nd</sup> OCC meeting, the status as informed by different beneficiaries is as follows:

| SN                     | Items                               | Status as given in 151 <sup>st</sup> OCC Meeting |                                 | Status as given in 152 <sup>nd</sup> OCC Meeting |                                 |
|------------------------|-------------------------------------|--|---------------------------------|--|---------------------------------|
|                        |                                     | Timeline for completion                          | Furnishing of detail parameters | Timeline for completion                          | Furnishing of detail parameters |
| <b>a. New Elements</b> |                                     |  |                                 |  |                                 |
| 1                      | 400/220kV, 315 MVA ICT-1 of NTPC at | By Jan'19  | To be submitted to NERLDC.      | By Mar'19  | To be submitted to NERLDC.      |

|    |  |   |  |   |  |
|----|--|---|--|---|--|
|    | Bongaigaon   |   |  |   |  |
| 2  | Kameng HEP of NEEPCO two units (2 x 150 MW)<br>Next two units (2x150 MW) | To be reviewed  | Already submitted.                           | By Mar'19   | Already submitted.                           |
| 3  | 132kV Monarchak – Surjamaninagar D/C of TSECL                            | by Jun'19   | To be submitted to NERLDC.                   | by Jun'19   | To be submitted to NERLDC.                   |
| 4  | 400/220 kV 315 MVA ICT-II at Bongaigaon                                  | HV side charged, LV side by Mar'19  | LV side separate application to be submitted | LV side (GIS) is expected to be completed by Mar'19.            | LV side separate application to be submitted |
| 5  | 220/132 kV, 160MVA ICT-II at Balipara                                    | ICT damaged in transit. Uncertain.  | To be submitted to NERLDC.                   | Not allowed for transit by WB Govt. to factory. Uncertain date. | To be submitted to NERLDC.                   |
| 6  | 220/132 kV, 1x160 MVA ICT with GIS Bay at Kopili                         | March 2019 (Delay in Supply)  | To be submitted to NERLDC.                   | Expected to be completed by Mar'19                              | To be submitted to NERLDC.                   |
| 7  | 33kV bay at 220kV Mariani(AS) S/Sn                                       | APDCL has submitted estimate. Payment expected by Dec'19                            | Not applicable.                              | PG to pay by Jan'19   | Not applicable.                              |
| 8  | 33kV bay for 132kV Badarpur(PG) S/Sn                                     | To be expedited by APDCL. Latest status to be submitted ASAP.                       | Not applicable.                              | To be expedited by APDCL.                                       | Not applicable.                              |
| 9  | Dedicated 33kV feeder at Khliehriat Substation from Lumshnong.           | SLDC Meghalaya to co-ordinate.  | Not applicable.                              | To be taken up with MePDCL. SLDC to kindly mediate.             | Not applicable.                              |
| 10 | Replacement of 2x315 MVA ICTs with 2x500 MVA ICTs at Misa (PG)           | ICT-I : May'19<br>ICT-II: Jun'19<br>Tertiary re-arrangement approved in 1st NERSCT. | To be submitted to NERLDC.                   | ICT-I expected by May'19 and ICT-II by Jun'19                   | To be submitted to NERLDC.                   |

| <b>b. Elements under breakdown/upgradation</b> |   |  |                           |  |                           |
|--|---|--|---------------------------|--|---------------------------|
| 11   | Up-gradation of 132 kV Lumshnong-Panchgram line   | Queries/ revised study to be submitted by SLDC.  | Not applicable.           | DPR sent to NLDC/NPC   | Not applicable.           |
| 12   | Switchable line Reactors at 400 kV Balipara & Bongaigoan Ckt # 1 & 2                                  | Reactors charged. CSD tuning to be done. By Dec'18   | Not applicable            | Balipara : CSD tuned for Ckt-1 S/D applied for Ckt-II on 04.02.19<br>Bongaigaon: Completed | Not applicable            |
| 13   | PLCC Panels at Loktak end of Loktak - Ningthoukhong 132 kV feeder and Loktak - Rengpang 132 kV feeder | PLCC panels at Rengpang & Ningthoukong end completed. Loktak end by Dec'18                                   | Not applicable.           | Panels not supplied at Loktak end. NERPC to write to MD, MSPCL to expedite.                | Not applicable.           |
| 14   | Upgradation of 132 kV Silchar-Impal to 400 kV   | One circuit upgradation by Dec'18.   | To be submitted to NERLDC | Ckt#II-upgraded on 25.12.18<br>Ckt#I: By Jan'19  | To be submitted to NERLDC |
| 15   | Replacement of CTs and installation of Bus Bar Protection at 220 kV Misa                              | <ul style="list-style-type: none"> <li>● CT Replaced</li> <li>● Relay Replacement by January 2019</li> </ul> | Not applicable            | Expected Completion : Mar'19   | Not applicable            |
| 16   | Upgradation of 132 kV Bus Bar at Umiam Stg-III to ACSR Zebra  | MePGCL to send proposal to NLDC/NPC.   | Not applicable            | DPR will be submitted soon.  | Not applicable            |
| 17   | Integration of existing bays with C264 RTU at RHEP by NEEPCO  | By Jan'19  | Not applicable            | By Jan'19  | Not applicable            |
| 18   | 220/132 kV 30 MVA ICT at Mokokchung   | Mar'19(LOA date)   | To be submitted to NERLDC | Mar'19(LOA date) to be reviewed later on.  | To be submitted to NERLDC |

**The Sub-Committee noted as above.**

**Action: All state utilities/central utilities/NERPC.**

**D. NEW ITEMS**

**D.1 Generation Planning (ongoing and planned outages)**

NEEPCO/NHPC may kindly intimate the availability for hydro stations:

- a. Present per day MU and projected number of days of operation.

| Plants                   | Reservoirs level in meter as on 10-01-19 | MU content | Present DC (in MU) | No of days as per current generation |
|--------------------------|--|------------|--------------------|--------------------------------------|
| Khandong + Kopili stg II | 719.30                                   | 24.67      | 0.198              | 125                                  |
| Kopili                   | 609.60                                   | 196.88     | 1.104              | 85                                   |
| Doyang                   | 323.00                                   | 66.9       | 0.15275            | 438                                  |
| Loktak                   | 767.71                                   | 75.9       | 1.097              | 71                                   |

Thus, for maintaining the generation availability of NER Region it is requested to all hydro generations to judiciously plan the utilization of water and furnish the day ahead declared MU such that NER Region does not face lack of generation availability in the upcoming lean hydro season.

The outage of other generating stations may be approved considering the present water levels in reservoirs.

**Deliberation in the Meeting:**

Sr. Manager, NEEPCO informed that the shutdown of Kopili Unit# I &II is very essential due to replacement of MIV for Unit#II. He requested that RHEP plant shutdown may please be approved as proposed since all arrangements are tied up.

SE(SO&PSC), DoP Ar.Pradesh strongly objected to plant shutdown of all Hydro Station together with thermal generation not in full capacity. In such a situation Ar. Pradesh will be the most affected state as most of the power requirement comes from RHEP and Pare HEP. In such a situation Ar. Pradesh grid will collapse. He agreed to the plant shutdown in the following manner:

1. That NEEPCO opt for sequencing the plant shutdown depending on the severity of the plant condition.
2. All thermal stations should generate in full capacity and allocation of some of Ar. Pradesh share from Hydel stations is done from thermal station during

plant shutdown.

3. Exploring possibility of importing from ER may be done.

NERLDC informed that TTC/ATC is restricted due to congestion in ER network as well as internal network. So import of higher quantum of power from ER will not be feasible. TTC/ATC will be revised according to the system condition for this period. To manage the load generation balance during this period, all thermal and gas generators are requested to maximize their generation and all beneficiaries are requested to strictly maintain their drawl schedule. NERLDC also requested that all critical planned shutdown may be rescheduled to avoid any threat to grid security and reliability during the period.

After detailed deliberation the following were decided:

- RHEP plant shutdown approved from 10:00hrs of 01.02.19 to 24:00hrs of 31.03.19.
- The shutdown of Kopili Unit #I&II is not being approved at present and would be taken up in next OCCM.
- Forum also approved the shutdown of Loktak Unit #I, II &III as proposed.
- PG test of Monarchak is to be re-scheduled subjected to availability of hydro units in NER.
- NERPC will write a letter to BgTPP for ensuring coal availability at BgTPP during the shutdown period. Meanwhile, NERPC will notify the matter to CEA & MoP. Forum requested BgTPP to ensure coal stock for minimum of 5 days.

***The Committee discussed and approved the proposed shutdown by Generating Stations and the same has already been uploaded in the website of NERPC.***

***Action: All generating utilities/NERLDC.***

## **D.2 Outage Planning Transmission elements**

It was agreed in the 99<sup>th</sup> OCC meeting that shutdown will be availed only after approval is given by the OCC forum. It was also agreed that deferment/revision of outages elements other than already approved in OCC will be henceforth put/displayed in the website of NERPC (**under Operational Activities/OCC Approved shutdown**) as per CERC regulations/ CEA guidelines etc for ensuring smooth & secure grid operation.

**Furnishing request of shut down of the element, which was approved by NERPC, by Indenting Agency (ISTS licensees/STUs/Generating Companies) to NERLDC:**

Planned shutdown approved by NERPC shall be considered for implementation by NERLDC on D-3 basis. If an outage is to be availed on say 10<sup>th</sup> of the month, the shutdown availing agency would reconfirm to NERLDC on 7<sup>th</sup> of the month by 10:00 Hr. This practice is necessary to ensure optimal capacity utilization and the time required for associated system study/coordination by/amongst RLDC/NLDC.

In 134<sup>th</sup> OCCM, it was decided that all communication related shutdown be approved in OCC forum only.

In 142<sup>nd</sup> OCCM, Director (O&P), NERPC suggested that henceforth shutdown list may be prepared under following categories:

- (i) New Construction Related Shut Down
- (ii) Existing System Improvement Related Shut Down.
- (iii) Existing System Normal Maintenance Related Shut Down
- (iv) Communication Related Shutdown
- (v) R&U works Related Shut Down under PSDF

The forum further decided that the modalities of communication related shutdown should be finalized. Members requested NERPC to invite POWERGRID telecom in next OCCM alongwith with officials (handling communication issues) from all utilities for this purpose.

**Deliberation in the Meeting:**

NERLDC highlighted that OCC forum approves the S/D after lots of discussion but it is observed that some of the shutdowns are not being availed. Details of Shutdown not availed and shutdowns applied on D-3 basis is as below:

| Total S/D approved | Total S/D availed | Total S/D not availed | Total S/D availed on D-3 basis | Total S/D not applied on D-3 basis |
|--------------------|-------------------|-----------------------|--------------------------------|------------------------------------|
| 121                | 109               | 12                    | 114                            | 121                                |

NERLDC highlighted that the inordinate delay in revival of elements under S/D for ISTS licensees is coming very high which is affecting the secure operation of the grid. Details for the month of November, 2018 are as below:

| Transmission Licensee | Total Delay | Avg. Delay | Max. Delay |
|-----------------------|-------------|------------|------------|
| POWERGRID             | 251:18      | 05:35:04   | 53:04      |

|       |       |          |       |
|-------|-------|----------|-------|
| NETC  | 05:13 | 02:36:30 | 05:09 |
| ENICL | -     | -        | -     |

Sr. GM NERTS assured that upgradation of 132kV Silchar-Imphal Ckt#I would be completed by Jan'19. For this S/D shall be applied on D-3, as the Bus Reactor at Imphal shall also have to be ready.

*The sub-Committee discussed and approved the proposals received from the constituents regarding transmission elements and generating units for January, 2019 - February,2019 and the same has already been uploaded in website of NERPC.*

**D.3 Estimated Transmission Availability Certificate (TAC) for the month of August, 2018 to October, 2018:**

NETC and POWERGRID have submitted the outage data for the month of August 2018 - October, 2018. So the attributability of outage of the said elements may please be finalized.

NERTS has informed that in order to process the monthly energy billing in time, it is desirable that within 30(thirty) days availability certificate is issued. It is to be deliberated how to issue the availability certificate within 30(thirty) days.

**Deliberation in the Meeting:**

Sr. GM, NERTS requested that deemed availability for 132kV Dimapur-Imphal may please be given till Mar'19 as the work is beyond control of PGCIL/DoP, Nagaland.

After detailed deliberations, the forum agreed to consider "Deemed Availability" of above line till 31.03.2019. No further consideration will be allowed thereafter.

NERLDC requested NETC & NERTS to submit the data to NERLDC by 5<sup>th</sup> of the month, so that verification can be completed within 15 days after submission of documents/data as per procedures.

*The Sub-Committee noted as above.*

**Action: Concerned transmission utilities/NERLDC/NERPC**

**D.4 Assessment of Total Transfer Capability (TTC), Transmission Reliability Margin (TRM) and Available Transfer Capability (ATC) by SLDC on respective Inter-State Transmission Corridor**

Updated PSS/E Base Cases have been mailed to all the SLDCs on 02.01.19. All SLDCs are requested to assess the Total Transfer Capability (TTC), Transmission Reliability Margin (TRM) and Available Transfer Capability (ATC) for the month of February 2019 using these cases and submit the study cases and results to NERLDC by 20.01.19.

**Deliberation in the meeting**

NERLDC has assessed TTC of each state control area of NER, each state subsystem on behalf of SLDCs of NER and group of control-area wise TTCs for NER Grid for the month of February'19 (considering N-1):

| States                         | Off Peak | Peak |
|--------------------------------|----------|------|
| Arunachal                      | 229      | 224  |
| Assam                          | 1624     | 1566 |
| Manipur                        | 223      | 213  |
| Meghalaya                      | 220      | 139  |
| Mizoram                        | 120      | 120  |
| Nagaland                       | 179      | 177  |
| Tripura (including Bangladesh) | 81       | 101  |

The forum decided that SLDC Ar. Pradesh would give present TTC/ATC calculation in the next OCC meeting. NERLDC requested that SLDC Ar. Pradesh depute officers for hands on training on TTC/ATC at NERLDC, Shillong on 24.01.19. NERLDC requested SLDCs to identify a person from each shift group for activities related to system study, protection issues and communication issues until the formation of the individual groups by respective SLDCs.

***The Sub-Committee noted as above.***

***Action: All SLDCs/STUs.***

**D.5. Update on Real Time Energy Assessment for Effective Grid Management:**

NERLDC has provided public IP of its server.

b) Following list of location for meters replacement / installation were submitted for the CDAC project:

| Sl. No | Feeder's Name                      | Status  | Meter to be replaced/Installed by PGCIL |
|--------|------------------------------------|---------|---|
| 1      | Srikona End of 132kV Silchar FDR-1 | Replace | 1                                       |

|    |                                     |         |   |
|----|-------------------------------------|---------|---|
| 2  | Srikona End of 132kV Silchar FDR-2  | Replace | 1 |
| 3  | Deomali End of 220kV Kathalhuri Fdr | Replace | 1 |
| 4  | PK Bari-I End of 132kV Silchar-1    | Replace | 1 |
| 5  | PK Bari-I End of 132kV Silchar-2    | Replace | 1 |
| 6  | Pavoi End of 132kV BNC-1            | Replace | 1 |
| 7  | Mokok (S) End of Doyang             | Replace | 1 |
| 8  | Mokok (S) End of Mokok-Mokok-1      | Replace | 1 |
| 9  | Mokok (S) End of Mokok-Mokok-2      | Replace | 1 |
| 10 | Khupi End of 132kV Balipara         | Install | 1 |
| 11 | Lekhi End of 132kV Pare             | Install | 1 |
| 12 | Khupi End of 132kV Kameng           | Install | 1 |
| 13 | Zuangtui End of Melriat             | Install | 1 |
| 14 | Luangmual End of Aizawl             | Install | 1 |

M/s CDAC has informed that pilot testing of Meter data acquisition of L&T Energy meters (2 No.) has been planned during 12<sup>th</sup> – 16<sup>th</sup> Nov 2018. The location identified for Pilot Testing is 400kV Azara Grid Sub-station, Assam

No. Of meters: 2 No.

AZARA END OF 400kV SILCHAR FDR

AZARA END OF 400kV BONGAIGAON FDR

In 150<sup>th</sup> OCC meeting DGM(MO), NERLDC informed that under pilot project, one TARA device has been installed at Azara S/S on 12.11.2018 with the SEM of Silchar feeder. DGM(MO), NERLDC, AGM-Assam SLDC, Manager(MO)-NERLDC and CDAC representatives were present during the process.

M/s CDAC is in the process of installing GUI at NERLDC server and after that continuous data receipt for two weeks would be tested. Subsequent to that, installation process in all NER locations would commence.

Regarding SIM for TARA devices, it was decided that NERPC would write to the nodal officers and respective department heads for procurement of SIM and handing over of the same to M/s CDAC at the earliest.

In 151<sup>st</sup> OCC meeting M/s CDAC informed the following:

- SRS, SAT has been approved.
- Beta version of software REALver1.0 has been installed at NERLDC.

- 8 locations of Assam meter data is reporting including one proprietary L&T meter at Azara. Reporting interval is 15min.
- Last 35 days data is being stored.
- 8 hardware servers have been delivered and 120 TARA devices has also been delivered.
- 79 location TARA remaining to be installed. The schedule of completion against each control area/states was finalised with overall target being Jan'19.
- The cables required in the respective sub-stations for connecting meter to the TARA devices shall be provided by the concerned utilities.

The forum decided that the following shall be the nodal officer for installation of TARA devices and configuration of software at SLDC premises:

1. Sh. D. Kamduk, SLDC, DoP Ar. Pradesh
2. Smt L. Ritu, SLDC, MSPCL
3. Sh. D. Das, SLDC, AEGCL
4. Sh. A. Koch, SLDC, MeECL
5. Sh. B. Tlumtea, SLDC, DoP Mizoram
6. Sh. R. Iralu, SLDC, DoP Nagaland
7. Sh. M. Paul, SLDC, TSECL

#### ***Deliberation in the meeting***

NERPC informed that linking of NERLDC WBES to CDAC backend is required for schedule to be visible (alongwith actual) at SLDC consoles. However since this was not in the original scope, an amount of ₹ 10lakhs as requested by CDAC has to be paid to them.

After detailed deliberation, members agreed in-principle the proposal of CDAC since schedule visibility is required at SLDC and requested NERPC to take up in next TCC/RPC for approval.

***The Sub-Committee noted as above.***

***Action: All utilities/NERPC.***

#### **D.6. Recording of operational instructions over VOIP in RLDC:**

Status as updated in 149th OCCM: NERTS informed that LOA already placed. Supply by 1month. Details of LOA shared with NERLDC.

GM(AM), NERTS informed that the device has been installed but switch problem remains. The same would be rectified by December, 2018.

**Deliberation in the meeting**

NERLDC informed that VOIP recording is working perfectly at NERLDC. The forum decided to drop the agenda item.

***The Sub-Committee noted as above.***

**D.7. Ensuring proper functioning of Under Frequency Relays(UFR) & df/dt Relays:**

In 7<sup>th</sup> NPC meeting held on 08.09.17 it was agreed that mock test is good enough to test the healthiness of the UFR & df/dt relays. The frequency of site inspection was proposed to be upto six months. RPC may carry out periodic inspection, in line with provisions of IEGC and furnish inspection reports to NPC.

Discussions as per previous meetings:-

- Inspection for Mawphlang completed.
- Inspection for Baghjap, Sankardevnagar and Sipajhar under Assam would be tentatively done in the first week of January 2019.

**Deliberation in the meeting**

Director (O&P), NERPC informed for the Assam stations as above UFR inspection is envisaged to be done on 29.01.19 & 30.01.19. He requested the support of AEGCL, NERTS and NERLDC for the same.

***The Sub-Committee noted as above.***

***Action: NERPC/NERTS/NERLDC/AEGCL.***

**D.8. VSAT for power system communications in NER:**

As per discussion in 10<sup>th</sup> NETeST meeting it was decided that VSAT for remote station connectivity would be explored. NERTS was requested to prepare DPR and present in 147<sup>th</sup> OCC.

In 151<sup>st</sup> OCCM Members of the group which visited Bangalore on 10.12.18 updated the forum of the technical aspects of the visit:

- Extended C Band Technology is being used by KPTCL. Same technology has to be replicated for NER.
- Minimum hardware is required at the remote stations and easy to install with only 3 units (modem, switch and antenna).
- Delay in receipt of data & voice is minimum and negligible.
- Voice communication is reliable and clear.

The team has confirmed that they are convinced about the performance of VSAT Communication Technology and that it is more suitable for NER Region.

The forum thanked the members for undertaking this visit and agreed to the implementation of Pilot Project. The forum requested the members for finalizing the modalities for implementation of pilot project. Members took cognizance of the view and referred the matter to the next NETeST meeting of NERPC for further discussion.

**Deliberation in the meeting**

Director, NERPC informed that the financial impact for NER states i.r.o. VSAT for Roing, Tezu, Namsai by POWERGRID is to be explored (tentative cost is • 54,653,880.00 for 5 years).

Further, he apprised the forum of the deliberations of the 12<sup>th</sup> NETeST meeting on 10.01.19 regarding pilot project of VSAT at Byrnihat. The tentative cost of • 5 lakhs is to be shared amongst all utilities. Members agreed in-principle for Pilot Project of VSAT for NER and requested NERPC to write to concerned authorities detailing the tentative cost etc.

***The Sub-Committee noted as above.***

***Action: NERTS/NERLDC/NERPC.***

**D.09. DIMAPUR\_PG Voice communication and telemetry out since Feb'18.**

In 148<sup>th</sup> OCCM DGM(AM), NERTS informed that Dimapur substation phone is working OK since March'18 (VOIP number 23640213). The same was restored along with power system restoration. Under urgency in March18, NERTS had collected one telephone from SLDC end and same was later replenished. For data, he informed that the same would be corrected by Nov'18.

In 151<sup>st</sup> OCCM NERTS informed that Dimapur voice communication has been restored and data would be restored by Feb'19.

**Deliberation in the meeting**

NERTS informed that voice communication already restored. Restoration of Telemetry Data is expected by Mar'19.

***The Sub-Committee noted as above.***

***Action: NERTS***

**D.10 Update on PDMS:**

The following were decided as per deliberation in the previous meeting(s):-

- All utilities to inform the name and details of SPOC (Single Point of Contact).
- Assam would be the Pilot state.
- M/s PRDC would organise a training program on PSCT tentatively on the first week of December, 2018. AEGC/ APDCL would host the same.

Further M/s PRDC has informed that for Operational Load Flow Study to be conducted by them selection of time ahead date and time stamp is required along with the following data:

- MW and MVAR flows for all station incomers and outgoing lines, transformers, reactors, cap banks and load points till 132 kV or 66kV. SCADA snapshot for that particular time stamp from NERLDC and state wise SLDCs.
- Voltage at all buses or nodes.
- Transformer tap positions.

In 151<sup>st</sup> OCCM PRDC representative informed the following status:

- Data has been collected from 30 locations of Assam.
- For 12 out of 30 locations relay setting has been obtained.
- Network modelling in PSCT has been initiated.
- Server is to be installed. In the interim data would be backed in PC based Server.
- Operational load flow date may be fixed.

After detailed deliberation it was decided that the date for operational load flow would be 19.12.2018(at 19:00 hrs). The forum requested all the utilities to submit the following data:

- MW and MVAR flows for all station incomers and outgoing lines, transformers, reactors, cap banks and load points till 132 kV or 66 kV. SCADA snapshot for that particular time stamp from NERLDC and state wise SLDCs.
- Voltage at all buses or nodes.
- Transformer tap positions.

It was decided that PRDC along with the help of NERPC & NERLDC would circulate formats to the respective utilities by 17.12.18.

**Deliberation in the meeting**

NERPC informed that the data w.r.t. Operational Load Flow is pending for the following utilities:

- Mizoram, Tripura -Entire data.
- Ar. Pradesh, Assam - Transmission Line Flows.

The forum requested the concerned SLDCs to submit the data at the earliest.

***The Sub-Committee noted as above.***

***Action: P&ED Mizoram, TSECL, DoP Ar.Pradesh, AEGCL.***

#### **D.11 Non Reporting of RTU at RHEP:**

Decision as per deliberation(s) in previous meetings:

- The bays on S900 RTU at RHEP have to be transferred to the existing C264 RTUs for 132kV RHEP-Chimpu D/C. For this MFTs are to be procured by NEEPCO. This has to be accelerated.
- NEEPCO to extend data upto the nearest wideband location through PLCC. ABB would visit RHEP by 21.11.2018 and the work would be completed by Nov'18.
- Scheme for connecting RHEP via BNC has been proposed to NEEPCO by POWERGRID, NEEPCO may review and take up.

In 151<sup>st</sup> OCCM NEEPCO informed the following status:

- Bays to be shifted on C264 by Dec'18
- Data to be extended upto nearest broadband i.e. BNC by Dec'18

#### **Deliberation in the meeting**

NEEPCO informed that shifting on C264 would be completed by Jan'19. NERTS informed that wideband would be extended upto RHEP through OPGW latest by Mar'19

***The Sub-Committee noted as above.***

***Action: NEEPCO***

#### **D.12 Telemetry Availability Status at NERLDC from Constituents (as on 07-11-2018):**

Telemetry status as on 02.01.2019 is attached in **Annexure- D.12**

#### **Deliberation in the meeting**

NERLDC highlighted about the present status of telemetry data in the region as on 2<sup>nd</sup> Jan'19. Forum took cognizance of the low availability of data for most states and referred the matter to the next Sub-group meeting of NETeST scheduled to be held

24.01.19. Members also requested all the state utilities to submit a list of RTUs proposed to be installed by them( except those already under SLDC Upgradation Project) to NERLDC.

***The Sub-Committee noted as above.***

***Action: All utilities, NERPC.***

**D.13 Utilization Certificate for Deposit Work of Construction of 33kV Transmission Line and Associated Bay from 220kV Mariani S/S(ASEB) to 220kV New Mariani S/S of POWERGRID**

An amount of Rs.100,34,749.00 was deposited to ASEB (vide DD N.o. 059528 Dated 04.08.2015 of Rs.7,81,032.00 + DD No. 914008 Dated 06.01.2014 for Rs.92,53,717.00 both Axis Bank) for the deposit work. As on date POWERGRID have received provisional utilization of Rs.59, 34,884.00 as detailed below:

i) Rs. 45, 47,620.00 from DGM, APDCL.

ii) Rs.13, 87,264.00 from AGM, 22kV Gid S/S AEGCL.

Balance utilization to be Received: Rs.40, 99,865.00

The above work has been completed long back, but final utilization certificate has not been issued till date inspite of repeated requests by POWERGRID. ASEB to resolve the issue at the earliest for issue of final utilization certificate.

In 150<sup>th</sup> OCCM APDCL was requested to issue the utilization certificate at the earliest. In 151<sup>st</sup> OCCM GM(AM), NERTS informed that APDCL has submitted the utilization certificate but AEGCL has yet to submit. The forum requested AEGCL to expedite.

**Deliberation in the meeting:**

AEGCL stated that they will issue utilization certificate latest by 31.01.19

***The Sub-Committee noted as above.***

***Action: AEGCL.***

**D.14 Submission of Load Forecast Data on (D-2)th day by constituents**

Study of Optimization of Generation Despatch of ISGS of NER is being carried out by NERLDC on daily basis using GAMS (General Algebraic Modeling System). The study results have been found to be helpful for day-ahead scheduling.

In order to facilitate the study, the forecasted load data is required to be received at NERLDC on (D-2)th day, D being the day for which the study is being conducted. It is

therefore, requested to send the load forecast data 2 days ahead instead of 1 day ahead that is being followed till date.

In 151<sup>st</sup> OCCM NERLDC informed the forum that Study of Optimization of Generation Despatch of ISGS of NER is being carried out by NERLDC on daily basis using GAMS. The study results have been found to be helpful for day-ahead scheduling. In order to facilitate the study, the forecasted load data is required to be received at NERLDC on (D-2)th day, D being the day for which the study is being conducted.

NERLDC informed that Arunachal Pradesh, Manipur, Meghalaya & Tripura are submitting the data. Assam, Nagaland & Mizoram were requested to send the data. After detailed deliberation, all SLDCs agreed to submit the load forecast data on D-2 basis.

**Deliberation in the meeting:**

NERLDC informed that all the utilities are submitting the data on D-2 basis. The forum decided to drop the agenda item.

***The Sub-Committee noted as above.***

**D.15. Submission of the Annual Load Generation Balance Report (LGBR) for Peak as well as Off-peak scenarios and the Annual outage plan for 2019-20 by 31.12.18 as per IEGC**

As per IEGC, each SLDC shall submit LGBR for its control area, for peak as well as off-peak scenario, **by 31<sup>st</sup> December for the next financial year**, to respective RPC Secretariat. The annual plans for managing deficits/surpluses in respective control areas shall clearly be indicated in the LGBR submitted by SLDCs.

As per IEGC, all SEBs/STUs, Transmission Licensees, CTU, ISGS, IPPs, MPPs and other generating stations shall provide to the respective RPC Secretariat their proposed outage plan in writing for **the next financial year by 31<sup>st</sup> October of each year**. These shall contain identification of each generating unit/transmission line/ICT etc., the preferred date for each outage and its duration and where there is flexibility, the earliest start date and latest finishing date.

**Deliberation in the meeting:**

NERLDC emphasized the importance of LGBR and informed that the same is being considered for the TTC/ATC calculation on 5 months ahead basis.

Director, NERPC requested all the utilities to submit the data at the earliest so that LGBR for 2019-20 can be finalised by 20.01.19

***The Sub-Committee noted as above.***

***Action: All utilities.***

**D.16 Problems in synchronization of lines in Ar.Pradesh system:**

In 151<sup>st</sup> OCCM SE(SO&PSC), DoP Ar. Pradesh informed that after shutdown/tripping of 132kV RHEP-Chimpu and 132kV Pare-Lekhi-Nirjuli synchronization problems are arising due to absence of check sync facility at Lekhi/Chimpu. He requested that:

- RHEP may please put in sync check facility at RHEP end for 132kV RHEP-Chimpu direct line.
- For 132kV Pare-Lekhi-Nirjuli sync may please be carried out at Nirjuli S/S instead of Lekhi for normalisation after shutdown.

NERTS confirmed that check sync is available at Nirjuli(PG). NEEPCO informed that check sync facility would be enabled by Dec'18.

NERLDC requested NEEPCO to do check sync facility for all the feeders from Ranganadi at the earliest.

**Deliberation in the meeting:**

NEEPCO informed that the check synch facility were successfully tested and implemented at Ranganadi End:

1. 132KV Pare-2 feeder was done on 21/12/2018
2. 132Kv Pare-1 feeder was done on 22/12/2018
3. 132Kv Chimpu feeder was done on 23/12/2018

The forum decided to drop the agenda item.

***The Sub-Committee noted as above.***

**D.17 Up gradation of 132kv Silchar – Imphal circuit # 1 to 400kV level**

The up-gradation of 132kV Silchar – Imphal Circuit # 2 to 400kV level has already been done on 25.12.2018 and power flow in circuit # 2 at 400kV level is almost 8 to 9 times compared to Circuit # 1 at 132kV Level. With the up-gradation of Circuit # 2, 400kV System first time entered in Manipur and the power scenario has improved considerably.

Now, up gradation of 132kV Silchar – Imphal Circuit # 1 to 400kV Level is proposed to be carried out by availing continuous Shut Down w.e.f., 14.01.19 to 17.01.19. The various activities involved for up-gradation is as below:

**AT IMPHAL (PG)**

1. Conversion of 132kV Silchar # 1 bay to 400/132kV, ICT # 1 LV side bay
2. Dismantling of 132kV Silchar # 1 line LAs and CVTs
3. Idle charging of 400/132kV, ICT # 1 for 24 Hours as per the practice
4. Stringing of 132kV Silchar – Imphal # 1 from 132kV Yard to 400kV Yard.
5. Dismantling of ERS from 132kV Silchar – Imphal # 1 used for entry at 132kV side

**AT SILCHAR (PG)**

1. Dismantling of ERS from 132kV Silchar – Imphal # 1
2. Stringing of 132kV Silchar – Imphal # 1 from 132kV Yard to 400kV Yard.

*NOTE: All the ERS towers utilised in 132kV Silchar – Imphal Line # 1 to be made free for utilization in Railway Diversion portion of 132kV Silchar – Imphal (PG) Line # 1 & 2 at Imphal so that, MSPCL can complete the construction of 400kV D/C Imphal (PG) – Thoubal (S) Line.*

**Deliberation in the meeting:**

NERTS informed that for keeping both the circuits in service at 400 kV, Bus Reactor at Imphal shall be required. The Bus Reactor at Imphal has developed some problem and internal inspection is to be carried out. Therefore, although the sequence of activities as described above, the continuous shut down of Ckt-I shall be applied on D-3, subject to readiness of the Bus Reactor at Imphal. The forum requested NERPC to accord the shutdown on D-3 basis as and when the reactor comes into service.

***The Sub-Committee noted as above.***

***Action: NERTS, NERPC.***

**D.18 NETC-Palatana-Bongaigaon transmission system: protection work at 8 nos. locations of 400 kV D/C Palatana-Silchar line which became vulnerable due to massive land slide and soil erosion.**

Palatana-Bongaigaon 400 kV D/C transmission system was developed for evacuation of power from 726.6 MW capacity, Gas Based Combined Cycle Power Plant (GBCCPP) of ONGC Tripura Power Company (OTPC) situated at Palatana, Tripura. The length of transmission system is 663 Km. 5 assets of the transmission system were commissioned in phases from 2012 to 2015.

Palatana-Silchar 400 kV D/C transmission line was commissioned in the month of July 2012 and is passing through 73 KMs of forest stretch in the state of Tripura. During construction, hill cutting was minimised by using uneven leg extensions for better stability.

During last year, the state of Tripura experienced unprecedented heavy monsoon with incessant rains in the month of June. The intensity of rain was so severe that within a time span of 7 – 10 days the free flowing rain water caused very heavy landslides in the entire hilly stretch of Tripura resulting no. of road blockages in the Inter-State National Highway which is the lifeline of Tripura including in some arterial roads. During the same time, the subject transmission line corridor also got affected.

Due to foregoing, 8 (eight) tower locations of 400 kV D/C Palatana-Silchar transmission line were badly affected which was beyond the control of NETC. Immediately after that, temporary measures for providing minimum protection were taken in those vulnerable locations by POWERGRID who is the Project Management Consultant for this project. These measures taken were most temporary for protecting the locations during that difficult time and hence shall not serve the purpose in the long run. Therefore, it is proposed to take immediate steps to provide permanent protection e.g.: RRM wall etc in those 8 (Eight) tower locations before the onset of ensuing monsoon.

The estimated expenditure of Rs. 154.00 Lakhs has been worked out by POWERGRID.

**Location wise estimated expenditure:**

1. Locn. 211 ----- Rs. 16.52 Lakhs
2. Locn. 218 ----- Rs. 9.44 Lakhs
3. Locn. 264 ----- Rs. 21.94 lakhs
4. Locn. 267 ----- Rs. 5.77 lakhs
5. Locn. 271 ----- Rs. 44.95 lakhs
6. Locn. 279 ----- Rs. 34.16 lakhs
7. Locn. 364 ----- Rs. 14.55 lakhs
8. Locn. 428 ----- Rs. 5.9 Lakhs

-----  
Total: Rs. 153.23 Lakhs

NETC being a very small Organization, it will be difficult on its part to bear such heavy expenditure. Therefore, it is proposed that the booking of such heavy expenditure be met through PoC mechanism.

**Deliberation in the meeting:**

NETC further informed the following:

- The ground situation is very precarious and the permanent protection i.e. RRM wall is to be provided for the 8 locations immediately. The said works have to be completed before the advent of monsoon.
- The RCE worked out by POWERGRID is • 168 lakhs.
- Due to the locations falling in forest land, diversion/ERS is not possible.

APDCL representative submitted that Assam is already immensely burdened under PoC regime. If this cost is further include it would add to the misery of poor consumers. Further he opined that since the works appear to be of maintenance nature, NETC may approach CERC for redressal so that normalised O&M cost may be revised.

After detailed deliberation, the following were decided:

- Work to be done by NETC immediately.
- NETC to assess the additional vulnerable locations if any and include the same under the scope.
- Concurrently NETC to submit petition to CERC for inclusion in tariff.

***The Sub-Committee noted as above.***

***Action: NETC.***

**D.19 Full schedule for PG Test:**

It is required to conduct PG test of C&I system of our plant NTPC BgTPP. Full schedule is required for atleast 12 hours per day for 2 to 3 days in order to conduct the PG Test.

**Deliberation in the meeting:**

The forum decided that during RHEP plant shutdown 01.02.2019 onwards, the PG test may be done. However coal stock is to be ensured by BgTPP five(5) days in advance before the commencement of PG test.

***The Sub-Committee noted as above.***

***Action: NTPC.***

**D.20 Permission for 1st time charging of 400/132 KV Switchyard of kameng Hydro Electric Project, NEEPCO**

**OBJECTIVE:** To check permission for 1<sup>st</sup> time charging of of 400/132 KV Switchyard of Kameng Hydro Electric Project, NEEPCO with one Data Channel from Powegrid's Balipara Sub-Station to with NERLDC Shillong

**BACKGROUND:**

1. NEEPCO's 4X150 MW Kameng HE Project was scheduled for commissioning in Mar-April 2018. However, during pre-commissioning stage on Mar 2018, leakages in penstock have been witnessed. The rectification works are presently on progress and it is anticipated that two units shall be ready for commissioning within March 2019.
2. In the meantime, NEEPCO has sought from NERLDC on 10/12/2018 for 1<sup>st</sup> time charging 400/132 KV Switchyard of the Project.
3. It is to be mentioned that the data telemetry with NERLDC, Shillong has been established subsequently and the data validations for all elements of the switchyard have since been completed.
4. For data communication, dual PLCC channel till wideband location i.e Balipara has been established. However, from Balipara to NERLDC Shillong, only one channel is presently made available.
5. For voice communication, dedicated Telephone (landline) has been provided and also alternative dedicated Voice Communication over PLCC has been established.
6. It has also been certified that the alternative channel through OPGW shall be available after completion of additional communication scheme by NERTS as approved in 18<sup>th</sup> NERPC meeting (item A.7).
7. NERLDC, however, desires that complete alternate two channels from Kameng HEP via Balipara to NERLDC shall be provided.
8. As per Connection Agreement drawn between NEEPCO and Powergrid, establishment of communication system from Balipara to NERLDC is in the scope of CTU i.e. Powergrid, however its cost shall be borne by NEEPCO. NEEPCO accordingly has taken up with Powergrid to provide the two channels from Balipara. Powergrid, however, informed that at present there is no additional spare channel readily available from Balipara to NERLDC and additional one channel shall be made available between Balipara to NERLDC by 2 months with installation of new equipment/cards at Balipara. Powergrid has

been requested vide letter dated 03/01/2019 (copy enclosed at **Annexure D.20**) for urgent action to make necessary arrangement to provide complete alternative two channels.

9. All NEEPCO's contractors viz. BHEL & Techno-Electric and its sub-contractors/vendors engaged in construction of NEEPCO's Switchyard and Power Station are waiting for clearances from NERLDC to charge and commissioning the Switchyard since last week of December 2018.

**PROPOSAL:**

With the above background and as establishment of the alternative channel from Balipara to NERLDC is beyond the control of NEEPCO, it is solicited that NERLDC may consider granting of provisional clearance to NEEPCO for charging of the Switchyard of Kameng HEP based on the Powergrid's assurance that the additional channel shall be made available in next 2 months time.

**Deliberation in the meeting:**

Director, NERPC apprised the forum of the discussions in the 12<sup>th</sup> NETeST meeting on 10.01.19. He informed that it was decided to grant provisional clearance to NEEPCO, and mentioned that POWERGRID has confirmed to provide additional channel at Balipara within Feb'19.

*The Sub-Committee noted as above.*

**Action: NERLDC/NERTS/NEEPCO.**

**D.21 Violation messages issued by NERLDC**

Details are attached in **Annexure-D.21**.

**Deliberation in the meeting:**

NERLDC highlighted the ZCV violations and its financial implications. NERLDC requested all utilities to strictly adhere to their schedule to avoid implications.

*The Sub-Committee noted as above.*

**Actions: All SLDCs**

**D.22 High percentage of non-OCC approved shutdown request**

Details are attached in **Annexure-D.22**.

**Deliberation in the meeting:**

NERLDC highlighted that grid operation is affected due to high percentage of non-OCC approved shutdowns. Around 30% of shutdowns in the month of Dec'18 were not approved in OCC meeting, which can be reduced by proper planning. NERLDC informed that some of the planned shutdowns are showed under emergency clauses. NERTS intimated that they will look in to this matter and proper documentary evidences will be submitted along with the emergency shutdown request for more clarity. NERPC informed that apart from shutdowns related to construction activities and PSDF projects, other shutdowns of planned nature should be discussed in the OCC meeting.

***The Sub-Committee noted as above.***

***Actions: All Concerned Utilities***

**D.23 Delayed returning of shutdown of important elements:**

Details are attached in **Annexure-D.23**.

**Deliberation in the meeting:**

NERLDC informed the forum that grid security is being compromised due to delay in return of shutdowns as per schedule like shutdown of 132 kV Silchar – Melriat D/C, 132 kV Silchar – Imphal 2 line, 220 kV Salakati – Aliprduar 1 & 2 lines etc. in the month of Dec'18. Market is also getting affected due to the delay in shutdown of some of the important corridors. After detailed deliberation, forum requested utilities to strictly adhere to the shutdown schedule.

***The Sub-Committee noted as above.***

**D.24 Ensuring thorough Patrolling (sag checking, tightening etc.) before seeking consent for commissioning of new elements to avoid multiple tripping incidents during first time charging.**

Details are attached in **Annexure-D.24**.

**Deliberation in the meeting:**

NERLDC informed the forum that several tripping of newly charged elements were observed in the month of Dec'18 and this is a matter of concern. After detailed deliberation, forum requested utilities to submit an undertaking to NERLDC before first time charging to ensure thorough Patrolling (sag checking, tightening etc.) before

seeking consent for commissioning of new elements to avoid multiple tripping incidents during first time charging.

***The Sub-Committee noted as above.***

***Actions: All Concerned Utilities***

**D.25 Non-availability/ Non-functioning of synchronization facility at the following stations**

- |                   |                         |
|-------------------|-------------------------|
| a) Kumarghat (PG) | d) Itanagar/Chimpu (AP) |
| b) Mariani (AS)   | e) Nirjuli (PG)         |
| c) Lekhi (AP)     | f) Gohpur (AS)          |

**Deliberation in the meeting:**

NERTS informed that synchronization facility is available at RTAMC for the POWERGRID stations. After detailed deliberation, it was decided that utilities should identify the 132 kV and above voltage level stations where synchronization facility is not available by Jan'19 and take necessary actions to procure synchronization facility.

***The Sub-Committee noted as above.***

**D.26 Consideration of outage of bus as N-1 Contingency for Bus Outages**

Presently Outage of Bus is not being considered as a credible N-1 contingency during outage of Buses in North Eastern Region. On 15/12/18, 400 kV Bus II at Silchar S/s was under shutdown and all the 400 kV Lines emanating from Silchar S/s and other elements were connected to 400 kV Bus I of Silchar S/s. Under this condition, Bus I tripped leading to zero power flow in 400 kV Palatana — Silchar I and 400 kV Silchar — Killing S/C as both these lines share dias with Bus Reactors at Silchar S/s. This led to problems of reliable generation evacuation of Palatana and overloading of 400/132 kV ICT II at Silchar.

Therefore, it is proposed that Outage of Bus may be considered as a credible N-1 Contingency in all the substations in NER.

**Deliberation in the meeting:**

NERLDC highlighted the importance of consideration of outage of Bus as a credible N-1 Contingency. AEGCL opined that SPS may be designed for outage of 400 kV Silchar bus. After detailed deliberation, it was decided that SPS is to be designed for outage of

400 kV Silchar bus. Director, NERPC informed that this will be discussed in the Subgroup meeting for System Study.

***The Sub-Committee noted as above.***

***Actions: NERPC***

**D.27 Near Miss Incident in NER Grid on 15.12.18 & 18.12.18 and Manipur Blackout incident on 26.12.18**

Two numbers of near miss incident occurred in NER Grid on 15.12.18 & 18.12.18 and a major grid disturbance occurred in Manipur Power System on 26.12.18.

- a. Tripping of 400 kV Bus 1 at Silchar (PG) at 10:29 Hrs on 15.12.18 leading to 150 % of loading of 400/132 kV, 200 MVA ICT -2 at Silchar for 50 min endangering the system security. *Non- furnishing of FIR, DR and other details sought by NELDC for detailed analysis.*
- b. Tripping of 400 kV Bus 2 at Balipara (PG) at 22:22 Hrs on 18.12.18.  
*No details received for detailed analysis.*
- c. Multiple element tripping on 26.12.18 leading to Blackout at Manipur Power System with a load loss of about 168 MW.

Communication from NERLDC has been forwarded to NERTS for furnishing detailed analysis of the above-mentioned events (Annexure-D.27). Reply from NERTS is awaited.

**Deliberation in the meeting:**

NERLDC expressed the concerns of 2 nos. operations of Busbar protection in 400 kV substations of POWERGRID which are very critical for NER grid. Blackout of 400/132 kV Imphal (PG) on 26.12.18 is also a matter of concern and analysis of these events may be done the earliest to avoid recurrence. Forum noted the same and referred to subgroup of protection for detailed analysis.

***The Sub-Committee noted as above.***

***Actions: NERPC***

**D.28 Organizing PCC Meeting on Monthly basis:**

NER grid is growing very fast and new elements have been added to the grid recently and many are planned to be commissioned in the next few months. It is very much essential to resolve the issues pertaining to protection system as quickly as possible.

Recent Grid events which occurred on 15.12.18, 18.12.18 and 26.12.18 are a matter of concern and are yet to be discussed in the subgroup/ PCC meeting.

During 2018, there were 211 Nos. of Grid Disturbances in NER Power System. To reduce the number of GDs it is essential to identify the root cause of the events and take remedial actions at the earliest.

It is thus proposed that PCC meeting may be organized on monthly basis so as to address the protection issues at the earliest.

**Deliberation in the meeting:**

Member Secretary, NERPC informed that earlier PCC meetings used to be held on a monthly basis, however due to very poor attendance from member utilities it is being convened quarterly. Further, he stated that now a Sub-group has been formed to have focused discussion/RCA of various trippings; hence ornazising PCC every month is not required and may be reviewed later.

***The Sub-Committee noted as above.***

**D.29 Circuit Breaker between Air Insulated Substation (AIS) and Gas Insulated Substation (GIS)**

Recently GIS has been commissioned at 400 kV Silchar Substation. In order to integrate the AIS and GIS, the shutdown of AIS was required. Also, during coordination of protection setting between AIS and GIS, AIS bus tripped leading to near miss incident on 15/12/18.

It is suggested to install circuit breaker between AIS and GIS so that integration of GIS with AIS and maintenance of AIS bus could be done without taking the shutdown of the GIS and vice-versa in all the hybrid substations of NER

**Deliberation in the meeting:**

NERLDC proposed to install circuit breaker between AIS and GIS so that integration of GIS with AIS and maintenance of AIS bus could be done without taking the shutdown of the GIS and vice-versa in all the hybrid substations of NER.

Members agreed in-principle to the proposal of NERLDC and put up to TCC/RPC for approval.

***The Sub-Committee noted as above.***

***Actions: NERPC***

**D.30 Expedite Commissioning of 400 kV Transfer Bus**

Details is attached in **Annexure-D.30**.

**Deliberation in the meeting:**

Forum expressed concerned about the delay in commissioning of the transfer bus at BgTPP. NTPC informed that transfer bus will be commissioned by 21.01.19. Forum decided that PG test of NTPC is to be scheduled subjected to the commissioning of transfer bus at BgTPP.

***The Sub-Committee noted as above.***

***Actions: NTPC***

**D.31 Publishing of Reactive Power Management Manual for NER Region-2018**

The 10th edition of Reactive Power Management Manual for NER Region for the year 2018 has been published in the NERLDC website.

**Deliberation in the meeting:**

NERLDC informed that the 10th edition of Reactive Power Management Manual for NER Region for the year 2018 has been published in the NERLDC website.

***The Sub-Committee noted as above.***

**D.32 Updation of Restoration Procedures of NER 2019:**

Draft of Restoration procedure of NER Grid 2019 has been circulated to all the constituents after incorporating all the necessary changes. All concerned are requested to please go through the Draft Restoration Procedure 2018 and give comments, if any, within 22nd January'19. The document will be finalized by 25th January'19.

**Deliberation in the meeting:**

NERLDC requested all concerned utilities to go through the Draft Restoration Procedure 2018 and give comments, if any, within 22nd January'19. The document will be finalized by 25th January'19.

***The Sub-Committee noted as above.***

***Actions: NTPC***

**D.33 Furnishing Technical and Commercial data for computation of PoC Charges and Losses for April to June'19 (Q1 of 2019-20):**

All the power utilities are requested to furnish Technical and Commercial data for computation of PoC Charges and Losses for April to June'19 (Q1 of 2019-20) by 15th January'19.

**Deliberation in the meeting:**

NERLDC requested all the power utilities to furnish Technical and Commercial data for computation of PoC Charges and Losses for April to June'19 (Q1 of 2019-20) by 15th January'19.

***The Sub-Committee noted as above.***

***Actions: All concerned utilities***

**D.34. Status review of the following items:**

- a. Software Procurement of Laptops
- b. Procurement of DCD
- c. Furnishing of Time drift in SEMs (Annexure-D.33)
- d. Non-receipt of SEM data

**Deliberation in the meeting:**

NERTS informed the following:

- a. Software Procurement of Laptops  
Under tendering. OBD expected by 31.01.19
- b. Procurement of DCD  
DCDs to be despatched to the constituents by M/S SANDS, Hyderabad by Jan'19.
- c. Furnishing of Time drift in SEMs (Annexure-D.33)

Time drift in POWERGRID SEMs shall be checked and report shall be submitted by 25.01.19

***The Sub-Committee noted as above.***

***Actions: NERTS***

**D.35. Rectifying the errors observed in meter readings:**

Details is attached in **Annexure-D.35**

**Deliberation in the meeting:**

NERTS informed the following:

Imphal end SEM for Dimapur feeder showing creepage; shall be replaced with spare if recommended.

SEM installed at Panchgram – defective CTs replaced, but with Ratio 300/1.

For the SEM installed at Karong for Kohima feeder, POWERGRID engineer shall visit Karong on 15.01.19.

***The Sub-Committee noted as above.***

***Actions: NERTS***

**D.36 Replacement of SEMs.**

| <i>Si. No</i> | <i>Location</i> | <i>Feeder Name</i>  |
|---------------|-----------------|---------------------|
| 1             | BNC             | BNC END OF PAVOI-I  |
| 2             | BNC             | BNC END OF PAVOI-II |
| 3             | BNC             | PAVOI END OF BNC-I  |

**Deliberation in the meeting:**

NERTS informed that replacement shall be done by 12.01.19

***The Sub-Committee noted as above.***

***Actions: NERTS***

**D.37 Spare Meters**

DPR has been submitted by NER States for SAMAST implementation. Techno Economic Group (TESG) of PSDF after scrutinizing the DPRs have asked to justify the reason of 10% spare meters as envisaged in the DPRs. While preparing the DPRs for NER States, the figure of 10% as considered for NER ISTS Metering was taken into account.

OCC may formally agree and record that 10% spare meter is being considered in NER ISTS and same is being followed by POWERGRID while procurement. In case of SAMAST also, same would be taken into account and TESSG would be informed accordingly.

For kind information only

***The Sub-Committee noted as above.***

**ADDITIONAL AGENDA FROM NERTS:**

**D.38 Storage of Regional Spare**

As the per MOM of 5th TCC & 15th NERPC Meeting held on 20th & 21st August, 2015 at Guwahati, following spare transformer were proposed for NER.

| SN | Proposed Spare Equipment                          |     | Remarks  | Present Location of the spare units   |
|----|---|-----|--|---|
|    | Rating  | Qty |  |   |
| 1. | 220/132 kV,<br>160 MVA<br>Transformer             | 1   | 4 units will be in service at Kopili & Balipara. 1 Spare shall be positioned at Kopili SS. | Due to space constraint at Kopili, the spare unit is installed in Balipara Substation |
| 4. | 400/220/33 kV, 315 MVA,<br>3-Phase<br>Transformer | 1   | 1 no. in service at Misa. 1 no each will be installed at Balipara & Bongaigaon.            | The spare unit is installed in Balipara Substation                                    |

For kind information only

***The Sub-Committee noted as above.***

**D.39 Final Revised Project cost for installation of 20 MVAR 220 kV Line Reactor at Kathalguri:**

The 20 MVAR 220 kV Line Reactor at Kathalguri was put in to service on 21.03.2017. the Reactor was installed by POWERGRID as deposit work of NEEPCO. The original project cost was Rs 4.444 Crore.

As recorded in 11<sup>th</sup> TCC & NERPC Meeting dtd 5<sup>th</sup> & 6<sup>th</sup> May'11 " the RPC had approved the estimated cost only (Rs 4.444 Crs), revised cost if any may be put to RPC to get it approved."

The final Project Cost is Rs 5, 73, 29,819.00 is put up for kind information of NEEPCO and the Forum.

**Deliberation in the Meeting:**

The forum recommended for TCC/RPC approval.

***The Sub-Committee noted as above.***

**Action: NERPC/NEEPCO**

**ADDITIONAL AGENDA FROM NERLDC:**

**D.40 Submission of data for modeling of RE generators**

**Deliberation in the Meeting:**

NERLDC informed that detailed guidelines have been framed for collection of data for steady state and dynamic modelling of utility scale Wind and Solar generation, including provision for storage. The guidelines incorporate comments from DiGSILENT Pacific team. These are aimed at collection of information prior to interconnection of utility scale renewable generation to the grid from the perspective of modelling. Guidelines for collection of data for steady state and dynamic modelling of utility scale Wind and Solar generation is attached as **Annexure-D.40**. NERLDC requested that these may be incorporated as part of documents that SLDCs seek from wind / solar plants prior to connection to the grid. NERLDC requested utilities to submit data required for modelling of RE generators especially Suryatap and Monarchak as per format attached as per **Annexure-D.40**. Members agreed the same.

***The Sub-Committee noted as above.***

***Action: NERPC/NEEPCO***

**Date & Venue of next OCC meeting**

It is proposed to hold the 153<sup>rd</sup> OCC meeting of NERPC on second week of February 2019. However, the exact date and venue will be intimated in due course.

The meeting ended with thanks to the Chair.

\*\*\*\*\*

**Annexure-I**

**List of Participants in the 152<sup>nd</sup> OCC Meeting held on 11<sup>th</sup> January, 2019**

| SN  | Name & Designation                          | Organization    | Contact No. |
|-----|---|-----------------|-------------|
| 1.  | Sh. N. Perme, SE (SO&PSC)                   | Ar. Pradesh     | 09436288643 |
| 2.  | Sh. K. Goswami, Consultant, APDCL           | Assam           | 09864020019 |
| 3.  | Sh. K. Gogoi, DGM,SLDC                      | Assam           | 09435301799 |
| 4.  | Sh. Dipesh Ch. Das, AGM (LDC)               | Assam           | 09954110254 |
| 5.  | Sh. Bimal Ch. Borah, AGM, SLDC              | Assam           | 09475119248 |
| 6.  | Sh. Pintu Dekaju, AGM (T&C)                 | Assam           | 09401516024 |
|     | <b>No Representative</b>                    | <b>Manipur</b>  | -           |
| 7.  | Sh. B. Nihla, EE (SP)                       | Meghalaya       | 09436314163 |
| 8.  | Sh. T. Gidon, EE, SLDC                      | Meghalaya       | 09774479956 |
| 9.  | Sh.Y. Iakai, AE, SLDC                       | Meghalaya       | 09402133552 |
| 10. | Sh. Marc N. Tariang, JE (System Protection) | Meghalaya       | 07005620013 |
| 11. | Sh. Benjamin L. Tlumtea, Sr. E.E, SLDC      | Mizoram         | 09436151424 |
| 12. | Zoramdina Ralte, SDO, MRT                   | Mizoram         | 08415901755 |
|     | <b>No Representative</b>                    | <b>Nagaland</b> | -           |
| 13. | Sh. Anil Debbarma, DGM, SOD, SLDC           | Tripura         | 09612589250 |
| 14. | Sh. Joypal Roy, Sr. Manager (E/M)           | NEEPCO          | 09435577726 |
| 15. | Sh. B.K. Chakraborty, DGM (E)               | NEEPCO          | 09436309730 |
| 16. | Sh. V. Suresh, CGM                          | NERLDC          | 09449599156 |
| 17. | Sh. Kamal K. Kumar, Dy. Manager (SO-I)      | NERLDC          | 09402187490 |
| 18. | Sh. Ankit Jain, Dy. Manager                 | NERLDC          | 0943633538  |
| 19. | Sh. M.P. Nath, Manager (MO)                 | NERLDC          | 09436335374 |
| 20. | Sh. Jerin Jacob, Asst. Manager              | NERLDC          | 09602120113 |
| 21. | Smti. Momai Dey, Dy. Manager                | NERLDC          | 09436302716 |
| 22. | Sh. Bornali Nath, Engineer                  | NERLDC          | 08414927752 |
| 23. | Sh.U. Katakai, Sr.GM                        | PGCIL           | 09435505418 |
| 24. | Sh. H. Talukdar, Sr.GM                      | PGCIL           | 09436335237 |
| 25. | Sh. N.Yugandhar, Sr. Manager                | NHPC            | 09800003819 |

|     |                                       |       |             |
|-----|---------------------------------------|-------|-------------|
| 26. | Sh. Subhajit Ganguly, Sr. Executive   | OTPC  | 07980010258 |
| 27. | Sh. Kangkan Paul, Dy. Manager         | NTPC  | 09435029230 |
| 28. | Sh. D.K. Sarma, Consultant            | NETC  | 09471001032 |
| 29. | Sh. Ratan Singh Basnet, Asst. Manager | NETC  | 08811072489 |
| 30. | Sh. P.K. Mishra, Member secretary     | NERPC | 09968380242 |
| 31. | Sh. B. Lyngkholi, Director (O&P)      | NERPC | 09436163419 |
| 32. | Sh. Farooque Iqbal, Dy. Director      | NERPC | -           |
| 33. | Sh. S. Mukherjee, AD                  | NERPC | 08794277306 |

**Telemetry Availability Status at NERLDC from Constituents (as on 02-01-2019):**

| Sl. No.  | Name of the Constituents | Total Analogue Data points | Total Digital Data points | Total Data Points | Analogue Data points Reporting | Digital Data Points Reporting | Total Reporting | Total Percentage of data Availability |
|----------|--------------------------|----------------------------|---------------------------|-------------------|--------------------------------|-------------------------------|-----------------|---------------------------------------|
| <b>1</b> | <b>Arunachal Pradesh</b> | <b>106</b>                 | <b>152</b>                | <b>258</b>        | <b>0</b>                       | <b>0</b>                      | <b>0</b>        | <b>0%</b>                             |
| <b>2</b> | <b>Assam</b>             | <b>1217</b>                | <b>1731</b>               | <b>2948</b>       | <b>492</b>                     | <b>512</b>                    | <b>1004</b>     | <b>34.05%</b>                         |
| 3        | Manipur                  | 180                        | 255                       | 435               | 106                            | 179                           | 285             | 65.51%                                |
| <b>4</b> | <b>Meghalaya</b>         | <b>409</b>                 | <b>388</b>                | <b>797</b>        | <b>220</b>                     | <b>56</b>                     | <b>276</b>      | <b>34.62%</b>                         |
| <b>5</b> | <b>Mizoram</b>           | <b>71</b>                  | <b>50</b>                 | <b>121</b>        | <b>9</b>                       | <b>7</b>                      | <b>16</b>       | <b>13.22%</b>                         |
| <b>6</b> | <b>Nagaland</b>          | <b>237</b>                 | <b>270</b>                | <b>507</b>        | <b>5</b>                       | <b>2</b>                      | <b>7</b>        | <b>1.38%</b>                          |
| <b>7</b> | <b>Tripura</b>           | <b>524</b>                 | <b>715</b>                | <b>1239</b>       | <b>138</b>                     | <b>134</b>                    | <b>272</b>      | <b>21.95%</b>                         |
| 8        | PGCIL                    | 628                        | 1082                      | 1710              | 396                            | 764                           | 1160            | 67.83%                                |
| 9        | NEEPCO                   | 202                        | 286                       | 488               | 125                            | 157                           | 282             | 57.78%                                |
| 10       | NTPC                     | 31                         | 49                        | 80                | 23                             | 49                            | 72              | 90%                                   |
| 11       | OTPC                     | 42                         | 85                        | 127               | 42                             | 85                            | 127             | 100%                                  |
| 12       | NHPC                     | 18                         | 29                        | 47                | 17                             | 27                            | 44              | 93.61%                                |
|          | <b>NER</b>               | <b>3647</b>                | <b>5063</b>               | <b>8710</b>       | <b>1556</b>                    | <b>1945</b>                   | <b>3501</b>     | <b>40.19%</b>                         |



ISO 9001 & 14001  
OHSAS 18001

नॉर्थ ईस्टर्न इलेक्ट्रिक पावर कॉर्पोरेशन लि.

(भारत सरकार का उद्यम)

**NORTH EASTERN ELECTRIC POWER CORPORATION LTD.**

(A GOVT. OF INDIA ENTERPRISE)

**OFFICE OF THE DIRECTOR (TECHNICAL)**



No. NEEPCO/D (T)/KaHEP-8/2018-19/ 467

Dated: 02.01.2019

To

The Executive Director,  
NERTS, Powergrid Corporation of India Ltd.,  
Lapalang, Shillong-793006

**Sub: 600 MW Kameng HEP. Reg. Data Communication with NERLDC via Balipara.**

Dear Sir,

We would like to inform that we have recently planned to charge the 400/132 kV Switchyard of our 600 MW Kameng HE Project and accordingly, we have approached NERLDC, Shillong on 10/12/2018 to grant clearance of 1<sup>st</sup> time charging of the switchyard.

You are aware that the pre-requisite for the getting clearance is the establishment of the data telemetry and voice communication between Power House of the Project and NERLDC, Shillong. With the co-operation and assistance from Powergrid, we could establish data telemetry and voice communication with NERLDC Shillong via Powergrid's Balipara Sub-station.

It is to be mentioned that for data telemetry, dual PLCC channel have been configured upto Balipara, whereas from Balipara to NERLDC, only one channel is made available. NERLDC has made the observation to provide complete alternate two channels from Kameng HEP via Balipara to NERLDC.

We understand that at present, there is no spare port available in Telecom panel at Balipara to make the alternative channel available upto NERLDC and in order to meet the requirement as observed by NERLDC, new equipment/cards or upgradation of the telecom panel at Balipara are required.

NERLDC is not granting the clearance to charge our switchyard without fulfilment of above requirement. It is to be mentioned that as per Connection Agreement between NEEPCO & Powergrid, providing communication from Balipara up to NERLDC is in the scope of Powergrid.

You may appreciate that all our contractors/vendors engaged in construction of our Switchyard and Power Station are waiting for clearances to charge and commission the Switchyard. We, therefore, request your intervention on the matter for urgent action to make necessary arrangement to provide complete alternate two channels to NERLDC.

Thanking you

Yours faithfully,

(V. K. Singh)

**Director (Technical)**



Pie Chart Representing Percentage Non-OCC Vs OCC Approved Shutdown

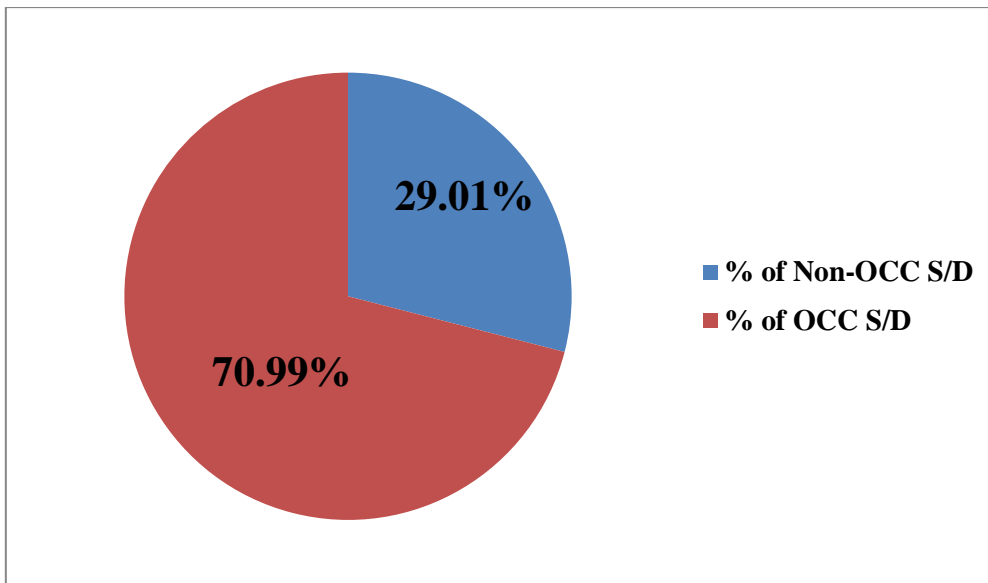

## Details of Inordinate Delay

| Sl. No.   | Line Name  | Owner            | Date               | Inordinate Delay |
|-----------|--|------------------|--------------------|------------------|
| 1         | +/- 800 kV HVDC Biswanath Chariali - Agra Pole 1 | POWERGRID        | 01-Dec-2018        | 02:12            |
| 2         | 400 kV Bongaigaon - Bus Reactor 2                | POWERGRID        | 07-Dec-2018        | 12:40            |
| 3         | 132 kV Lekhi - Pare 1                            | AP & POWERGRID   | 09-Dec-2018        | 02:05            |
| 4         | 400 kV Balipara - Bongaigaon 2                   | POWERGRID        | 10-Dec-2018        | 03:18            |
| 5         | 132 kV Aizawl - Kolasib                          | POWERGRID        | 12-Dec-2018        | 01:34            |
| 6         | 400 kV Biswanath Chariali - Ranganadi 2          | POWERGRID        | 15-Dec-2018        | 01:40            |
| 7         | 132 kV Imphal - Silchar 1                        | POWERGRID        | 15-Dec-2018        | 01:07            |
| 8         | 132 kV Imphal - Silchar 1                        | POWERGRID        | 16-Dec-2018        | 01:06            |
| <b>9</b>  | <b>132 kV Silchar - Melriat 1</b>                | <b>POWERGRID</b> | <b>18-Dec-2018</b> | <b>51:33</b>     |
| 10        | 400 kV Balipara - Biswanath Chariali 1           | POWERGRID        | 18-Dec-2018        | 04:02            |
| <b>11</b> | <b>132 kV Silchar - Melriat 2</b>                | <b>POWERGRID</b> | <b>18-Dec-2018</b> | <b>53:04</b>     |
| 12        | 400 kV Balipara - Biswanath Chariali 2           | POWERGRID        | 18-Dec-2018        | 06:51            |
| 13        | 400 kV Balipara - Biswanath Chariali 4           | POWERGRID        | 19-Dec-2018        | 02:58            |
| <b>14</b> | <b>132 kV Imphal - Silchar 2</b>                 | <b>POWERGRID</b> | <b>19-Dec-2018</b> | <b>49:51</b>     |
| 15        | 400 kV Azara - Bongaigaon                        | NETCL            | 19-Dec-2018        | 05:09            |
| 16        | 400 kV Balipara - Misa 1                         | POWERGRID        | 20-Dec-2018        | 02:09            |
| 17        | 400 kV Bongaigaon - New Siliguri (Binaguri) 1    | POWERGRID        | 20-Dec-2018        | 02:06            |
| 18        | 400 kV Bongaigaon - New Siliguri (Binaguri) 1    | POWERGRID        | 21-Dec-2018        | 01:36            |
| 19        | 132 kV Imphal - Silchar 1                        | POWERGRID        | 22-Dec-2018        | 04:55            |
| 20        | 400 kV Bongaigaon - Bus Reactor 2                | POWERGRID        | 22-Dec-2018        | 04:10            |
| 21        | 132 kV Agartala - AGTPP 2                        | POWERGRID        | 23-Dec-2018        | 01:11            |
| 22        | 1220 kV Salakati - Alipurduar                    | POWERGRID        | 26-Dec-2018        | 04:41            |
| 23        | 220 kV Salakati - Alipurduar 2                   | POWERGRID        | 26-Dec-2018        | 04:43            |
| 24        | 132 kV Agartala - AGTPP 2                        | POWERGRID        | 26-Dec-2018        | 01:24            |
| 25        | 400 kV Silchar - Imphal 2                        | POWERGRID        | 26-Dec-2018        | 05:44            |
| 26        | 220 kV Salakati - Alipurduar 1                   | POWERGRID        | 27-Dec-2018        | 03:39            |
| 27        | 220 kV Salakati - Alipurduar 2                   | POWERGRID        | 27-Dec-2018        | 03:40            |
| 28        | 400 kV Biswanath Chariali - Ranganadi 1          | POWERGRID        | 27-Dec-2018        | 01:30            |
| 29        | 132 kV Agartala - AGTPP 2                        | POWERGRID        | 27-Dec-2018        | 01:05            |
| 30        | 400/220 kV Misa - Transformer 2                  | POWERGRID        | 27-Dec-2018        | 02:44            |
| 31        | 132 kV Aizawl - Tipaimukh 1                      | POWERGRID        | 28-Dec-2018        | 01:25            |
| 32        | 132 kV Ranganadi - Ziro 1                        | POWERGRID        | 28-Dec-2018        | 01:34            |

## **Annexure-D**

132 kV Silchar – Imphal II was successfully charged at 400 kV level on 25.12.18 at 1651 Hrs. Prior to successfully charging of 400 kV Silchar – Imphal II line, the line tripped three times as mentioned below:

- i. Tripped immediately after charging at 1354 Hrs on 23.12.18
- ii. Tripped on DP, Y-ph, 41.7 km at 1541 Hrs on 23.12.18
- iii. Tripped on SOTF at 2212 Hrs on 23.12.18
- iv. Hand Tripped after successfully charging upto 58.3 km from Silchar end

400 kV Silchar- Imphal D/C lines are very critical lines for Manipur Power System. Tripping of important lines prior to first time charging poses a great threat to the system.

**पावर सिस्टम ऑपरेशन करपोरेशन लिमिटेड**  
(भारत सरकार का उद्यम)  
**POWER SYSTEM OPERATION CORPORATION LIMITED**  
(A Government of India Enterprise)



उत्तर पूर्वी क्षेत्रीय भार प्रेषण केंद्र : लोअर नंगरा, लापालांग, शिलांग-793006, (मेघालय)  
North Eastern Regional Load Despatch Centre: Lower Nongrah, Lapalang, Shillong - 793006, (Meghalaya)  
Ph : 0364-2537470, 2537427, Fax - 2537486 Website : www.nerlhc.org, Email - nerlhc@posoco.in, CIN : U40105DL2009GOI188682

संदर्भ : उपकोभाप्रेके/एस.ओ-11/ 2319  
Ref : NERLDC/SO11/2319

दिनांक/Date: 03.01.19

सेवा में/To:

Addl. General Manager (E.E),  
NTPC Limited, Bongaigaon Thermal Power Project  
PO: Salakati (P)  
District: Kokrajhar (BTAD)  
Assam, Pin Code: 783369

**विषय/Sub: Expedite commissioning of 400 kV Transfer Bus at Bongaigaon Thermal Power Plant, NTPC.**

महोदया / महोदय,

Switching scheme of Bongaigaon Thermal Power Plant (BgTPP), NTPC is Double Main and Transfer Bus as per the Single Line Diagram submitted by BgTPP, NTPC. However, during synchronization of Unit No. 3 at BgTPP it has been informed by BgTPP, NTPC that 400 kV Transfer Bus at BgTPP has not been commissioned yet.

This is for your information that shutdown of 400 kV Bus-II was availed on 02.01.19. During the shutdown period, all the elements connected to 400 kV BgTPP were shifted to Bus-I, thus reducing the reliability of the critical power station in North Eastern Region.

It is requested to kindly expedite the commissioning of 400 kV Transfer Bus at BgTPP, NTPC to enhance the reliability of BgTPP, NTPC.

धन्यवाद एवं सादर सहित।

भवदीय / Yours sincerely,

**अमल्लिक** 03.01.19  
(अ.मल्लिक / A. Mallick)

महाप्रबंधक (एस.ओ-2) G.M. (S.O.-II)

Meter error details:

| SL.NO | FEEDER NAME                     | METER NO  | REASON             | REMARKS                       |
|-------|---------------------------------|-----------|--------------------|-------------------------------|
| 1     | IMPHAL(PG) END OF DIMAPUR ( PG) | NP-8669-A | ERRORNEOUS READING |                               |
| 2     | PANCHGRAM END OF BDP(PG)FDR     | NP-6872-A | CT/PT ISSUE        | Other end used for accounting |

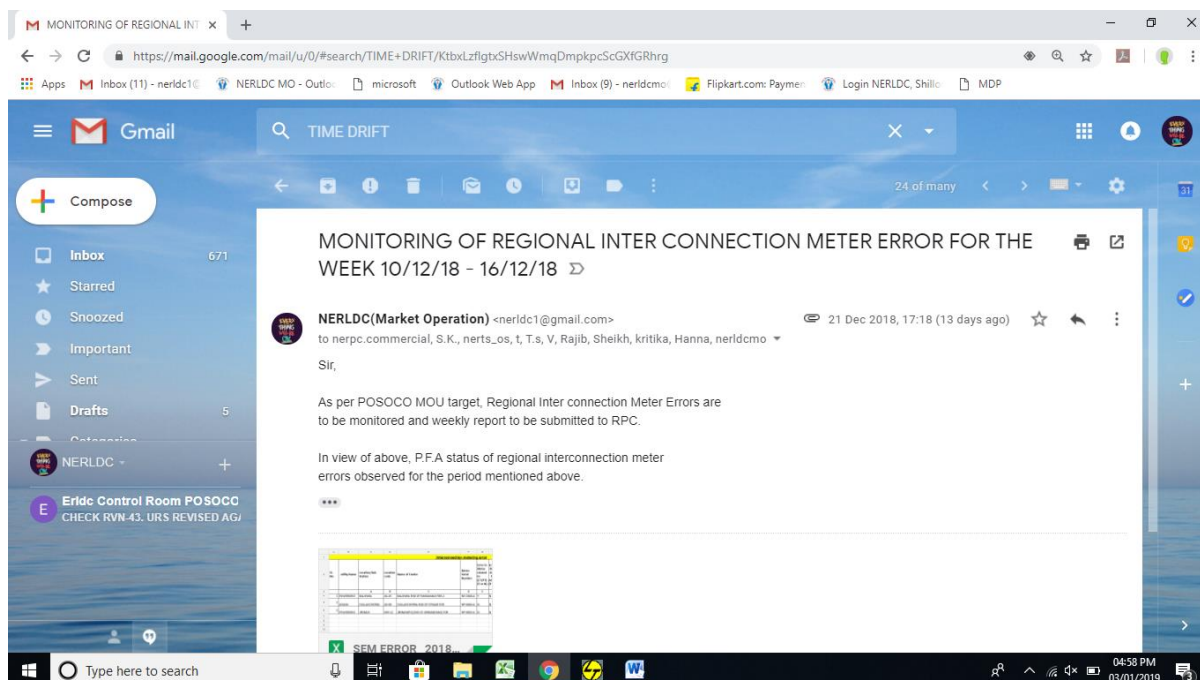
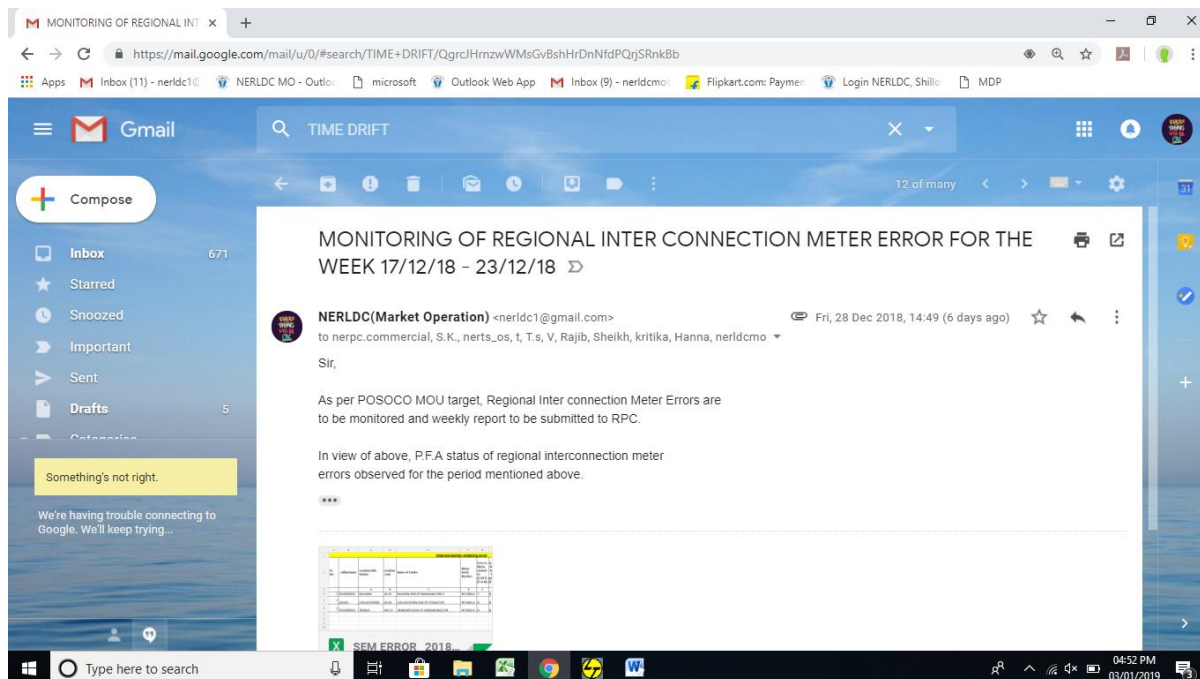

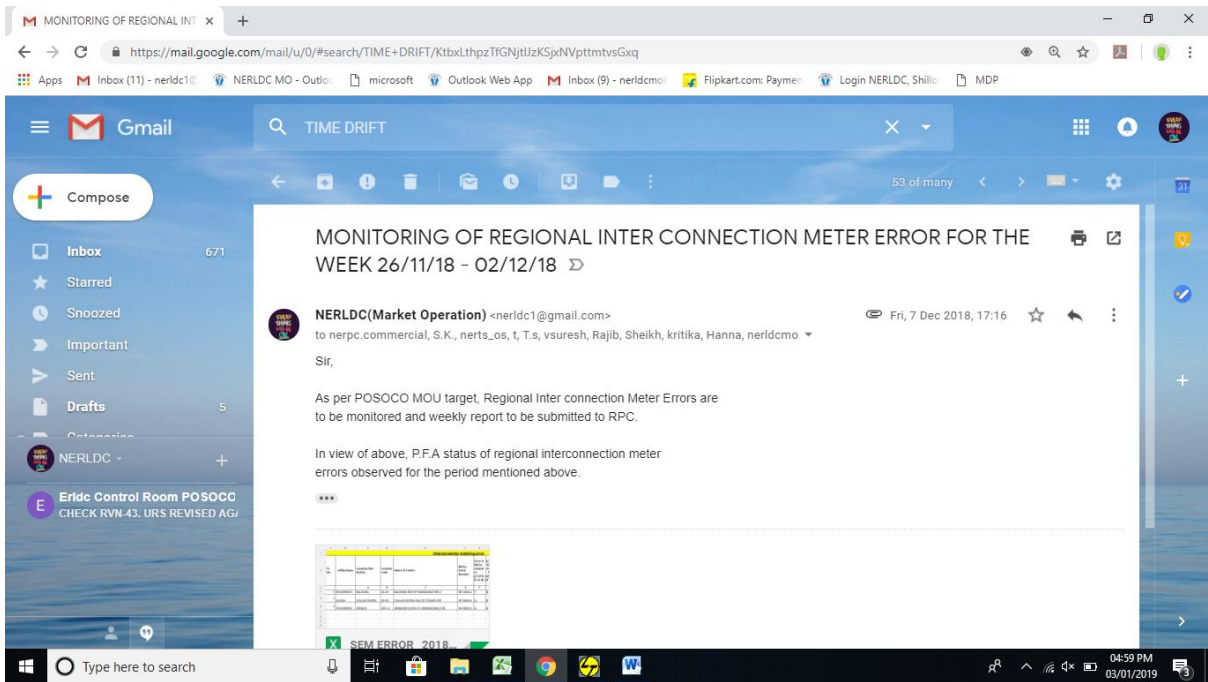
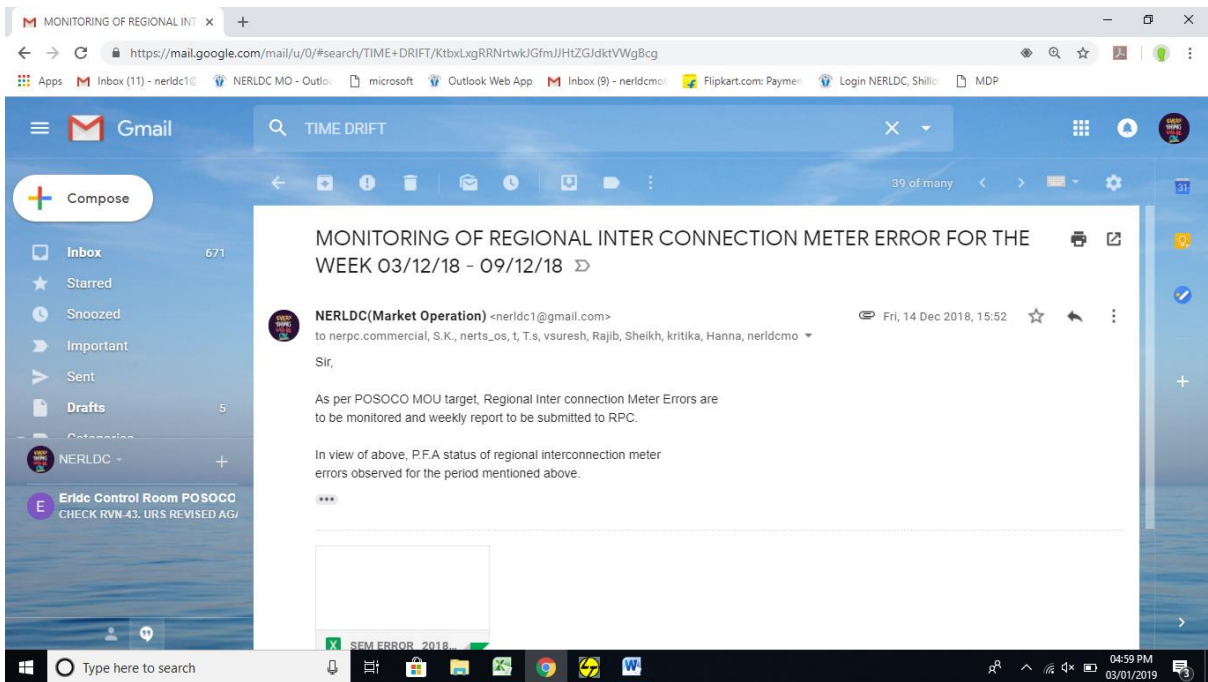

The screenshot shows a Gmail inbox on a Windows desktop. The browser address bar shows a search for "TIME+DRIFT". The email subject is "MONITORING OF REGIONAL INTER CONNECTION METER ERROR FOR THE WEEK 19/11/18 - 25/11/18". The sender is "NERLDC(Market Operation)" and the recipient is "nerpc.commercial, S.K., nerts\_os, t, T.s, vsuresh, Rajib, Sheikh, kritika, Hanna, nerldcmo". The email content states that regional interconnection meter errors are monitored weekly and reported to RPC. It also mentions a P.F.A status report for the period. A table titled "SEM ERROR 2018" is attached to the email. The Windows taskbar at the bottom shows the time as 04:59 PM on 03/01/2019.

MONITORING OF REGIONAL INTER CONNECTION METER ERROR FOR THE WEEK 19/11/18 - 25/11/18

NERLDC(Market Operation) <nerldc1@gmail.com>  
to nerpc.commercial, S.K., nerts\_os, t, T.s, vsuresh, Rajib, Sheikh, kritika, Hanna, nerldcmo

Fri, 30 Nov 2018, 16:03

Sir,

As per POSOCO MOU target, Regional Inter connection Meter Errors are to be monitored and weekly report to be submitted to RPC.

In view of above, P.F.A status of regional interconnection meter errors observed for the period mentioned above.

| Sl. No. | Area | Time | Value | Remarks |
|---------|------|------|-------|---------|
| 1       | ...  | ...  | ...   | ...     |
| 2       | ...  | ...  | ...   | ...     |
| 3       | ...  | ...  | ...   | ...     |
| 4       | ...  | ...  | ...   | ...     |
| 5       | ...  | ...  | ...   | ...     |
| 6       | ...  | ...  | ...   | ...     |
| 7       | ...  | ...  | ...   | ...     |
| 8       | ...  | ...  | ...   | ...     |
| 9       | ...  | ...  | ...   | ...     |
| 10      | ...  | ...  | ...   | ...     |
| 11      | ...  | ...  | ...   | ...     |
| 12      | ...  | ...  | ...   | ...     |
| 13      | ...  | ...  | ...   | ...     |
| 14      | ...  | ...  | ...   | ...     |
| 15      | ...  | ...  | ...   | ...     |
| 16      | ...  | ...  | ...   | ...     |
| 17      | ...  | ...  | ...   | ...     |
| 18      | ...  | ...  | ...   | ...     |
| 19      | ...  | ...  | ...   | ...     |
| 20      | ...  | ...  | ...   | ...     |
| 21      | ...  | ...  | ...   | ...     |
| 22      | ...  | ...  | ...   | ...     |
| 23      | ...  | ...  | ...   | ...     |
| 24      | ...  | ...  | ...   | ...     |
| 25      | ...  | ...  | ...   | ...     |
| 26      | ...  | ...  | ...   | ...     |
| 27      | ...  | ...  | ...   | ...     |
| 28      | ...  | ...  | ...   | ...     |
| 29      | ...  | ...  | ...   | ...     |
| 30      | ...  | ...  | ...   | ...     |
| 31      | ...  | ...  | ...   | ...     |
| 32      | ...  | ...  | ...   | ...     |
| 33      | ...  | ...  | ...   | ...     |
| 34      | ...  | ...  | ...   | ...     |
| 35      | ...  | ...  | ...   | ...     |
| 36      | ...  | ...  | ...   | ...     |
| 37      | ...  | ...  | ...   | ...     |
| 38      | ...  | ...  | ...   | ...     |
| 39      | ...  | ...  | ...   | ...     |
| 40      | ...  | ...  | ...   | ...     |
| 41      | ...  | ...  | ...   | ...     |
| 42      | ...  | ...  | ...   | ...     |
| 43      | ...  | ...  | ...   | ...     |
| 44      | ...  | ...  | ...   | ...     |
| 45      | ...  | ...  | ...   | ...     |
| 46      | ...  | ...  | ...   | ...     |
| 47      | ...  | ...  | ...   | ...     |
| 48      | ...  | ...  | ...   | ...     |
| 49      | ...  | ...  | ...   | ...     |
| 50      | ...  | ...  | ...   | ...     |
| 51      | ...  | ...  | ...   | ...     |
| 52      | ...  | ...  | ...   | ...     |
| 53      | ...  | ...  | ...   | ...     |
| 54      | ...  | ...  | ...   | ...     |
| 55      | ...  | ...  | ...   | ...     |
| 56      | ...  | ...  | ...   | ...     |
| 57      | ...  | ...  | ...   | ...     |
| 58      | ...  | ...  | ...   | ...     |
| 59      | ...  | ...  | ...   | ...     |
| 60      | ...  | ...  | ...   | ...     |
| 61      | ...  | ...  | ...   | ...     |
| 62      | ...  | ...  | ...   | ...     |
| 63      | ...  | ...  | ...   | ...     |
| 64      | ...  | ...  | ...   | ...     |
| 65      | ...  | ...  | ...   | ...     |
| 66      | ...  | ...  | ...   | ...     |



## Procedure for furnishing information for modelling Wind generating stations in Indian Grid

### 1.0 Introduction:

The purpose of this document is to act as a guideline for exchange of information for accurate modelling of wind farms and parks in India. With India poised to integrate more than 60 GW of utility scale wind generation, availability of fit-for-purpose steady state and dynamics models of wind turbine generators and wind parks will enable secure operation of Indian power grid and enable identification of potential weak points in the grid so as to take appropriate remedial actions.

### 1.1 Applicability:

The guideline shall be applicable to all utility scale wind farms in India that can have an impact on operation of the power grid of India, irrespective of connection at Intra-STS or ISTS (Inter-state Transmission System).

This document presents the desired information for collection of data for modelling of Wind generators / Wind farms or parks in PSS/E software, a software suite being used pan-India at CEA, CTU, SLDCs, RLDCs, and NLDC for modelling of India's power grid. A systematic set of data and basic criteria for furnishing data are presented.

### 1.2 Need for a fit-for-purpose model:

There is a cost involved in developing and validating dynamic models of power system equipment. But there are much higher benefits for the power system if this leads to a functional, fit-for-purpose model, and arrangements that allow that model to be maintained over time.

A functional fit-for-purpose dynamic model will:

- Facilitate significant power system efficiencies and reliability by allowing power system operations to confidently identify the secure operating envelope and thereby manage security effectively
- Allow assessment of impact on grid elements due to connection of new elements (network elements, generators, or loads) for necessary corrective actions
- Permit power system assets to be run with margins determined on the basis of security assessments
- Facilitate the tuning of control systems, such as power system stabilisers, voltage- and frequency-based special control schemes etc.
- Improve accuracy of online security tools, particularly for unusual operating conditions, which in turn is likely to result in higher reliability of supply to power system users.

The power system model would enable steady state and electromechanical transient stability simulation studies that deliver reasonably accurate outcomes. Detailed proprietary aerodynamics, electromagnetic

transient studies and proprietary individual inverter controls are out of the scope of the models under consideration. A generic Power Plant Controller (PPC) should be modeled for understanding the interactions with the grid.

### 2.0 Wind generation technologies:

The majority of commercially available wind power plants use one of the wind turbine-generator (WTG) technologies listed below:

- Type-1 : Direct connected (Squirrel cage) induction generator (SCIG)
  - Fixed Speed stall control
  - Fixed Speed Active control
- Type-2 : Wound rotor induction generator (WRIG) with a variable resistor in the rotor circuit
- Type-3 : Doubly fed induction generator (DFIG) wind turbines ; Variable speed with rotor side converter
- Type-4 : Full converter wind turbine
  - Synchronous generator
  - Permanent Magnet Generator (PMG)

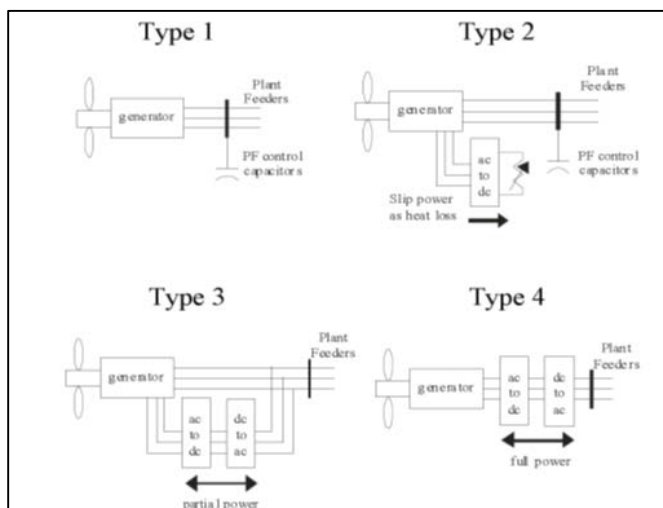

Wind energy plants are being increasingly coupled with complimentary Battery Energy Storage Systems (BESS) to reduce the variability of net power output from the renewable energy plant, provide higher output, or provide complimentary grid services such as frequency regulation. Modelling batteries / storage devices assume importance in such cases to capture the net impact of the plant on grid.

### 3.0 Models for Wind generators:

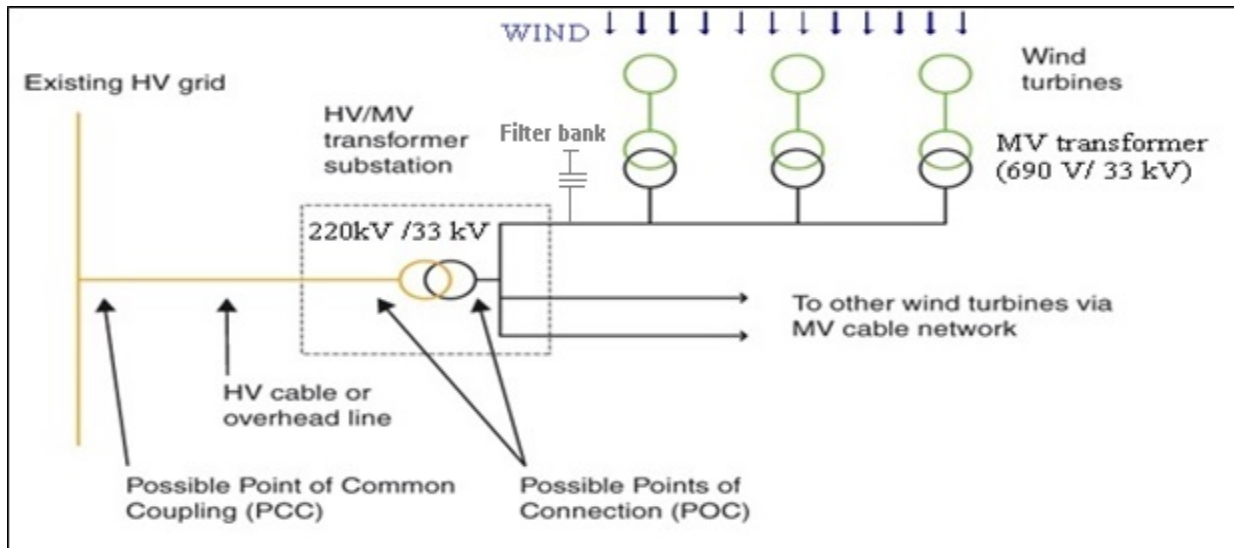

In a typical wind farm / park, individual WTGs (typically rated 3 MW or less) are connected in a system of twigs and feeders. Wind generation at around 660 V / 690 V is stepped up to a MV level of typically 33 kV in Indian system and finally pooled to grid at 220 kV / 400 kV through step-up transformers. A typical wind farm of 300 MW will be spread over an area of 600 acres, and power transmission within the farm is typically at 33 kV through overhead lines or underground cables. A Power Plant controllers (PPC) is usually installed at the point of interconnection to grid or at the reticulation system. The PPC(s) control behavior of wind farms in accordance with mandates as per grid codes.

The dynamic components of a wind farm consists of the following elements (illustrated in picture below):

1. Generator or Converter
2. Electrical control
3. Drive-Train model
4. Aerodynamics
5. Pitch controller
6. Torque controller
7. Power Plant Controller (PPC)
8. Energy storage (As applicable)

The components may or may not be present depending on the nature of technology used for wind power generation (i.e. type of turbine). Depending on the nature of technology, usage/configuration of components at site ('As built'), the requirements for steady state and dynamic modelling evolves.

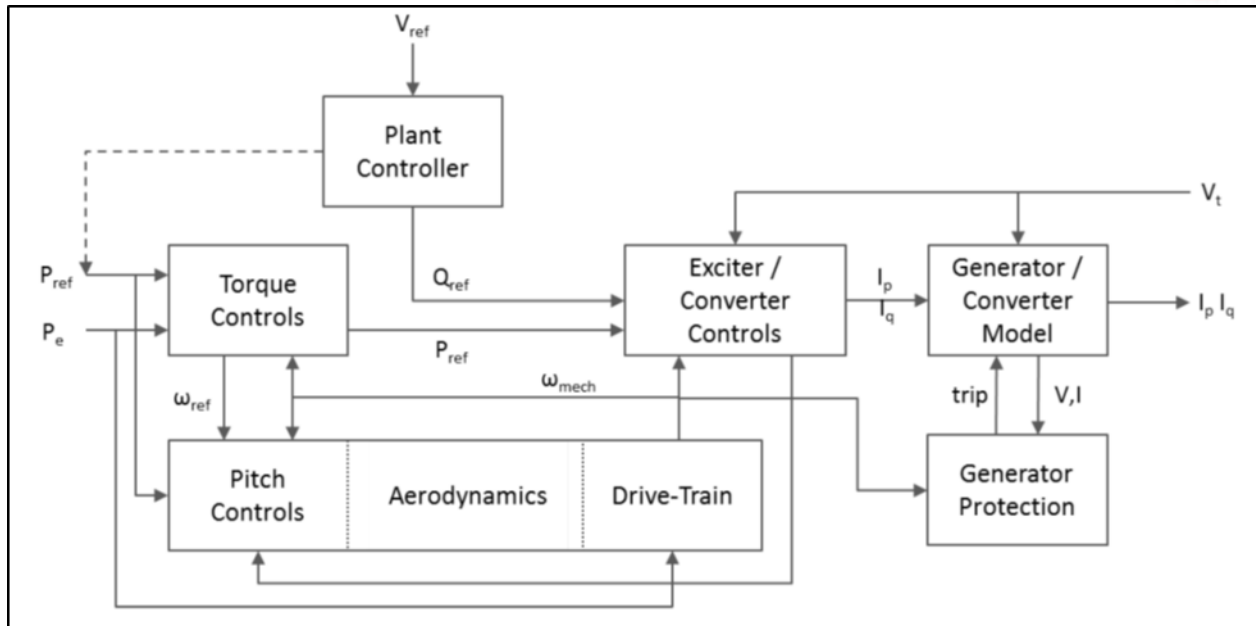

For POSOCO to have access to verified fit-for-purpose models of wind farms/ parks connected to Indian grid, the following information are required:

1. Electrical Single Line Diagram (SLD) of as built Wind farm /park depicting:
  - For individual WTGs: Type, MW rating, MVAR capability, Manufacturer, Model no., capability curve
  - Reticulation system (MV system within the wind farm): Length of individual branch / twig, Type of conductor, Electrical parameters (R, X, B)
  - Filters (active or passive) or capacitor banks
  - Details of MV (690V/33kV) and HV (33kV/220kV) step-up transformers: Rating, Impedance, Vector Group, Tap changers (Type, Tap Steps, Max Ratio and Min Ratio in p.u.)
  - Aggregated steady state model validated for P injection and Q injection at the point of interconnection.
2. Generic models of WTGs / Wind farms (Refer sections 3.1 to section 3.4)
  - Models should be suitable for an integration time step between 1ms and 20ms, and suitable for operation up-to 600s.
  - Including a Generic Power Plant Controller (PPC) model which represents the interaction of power plant with the grid. Settings of the Power Plant Controller may be tuned as per the existing setup on field.
  - Simulation results depicting validation of Generic models against User-Defined models (for P, Q, V, I) and against actual measurement (after commissioning) to be provided.
3. Encrypted user defined model (UDM) in a format suitable for latest release PSS/E (\*.dll files) for electromechanical transient simulation for components of WTGs / Wind farm (in case non-availability of validated generic model)



- User guide for Encrypted models to be provided including instructions on how the model should be set-up
  - Corresponding transfer function block diagrams to be provided
  - Simulation results depicting validation of User-Defined models against actual measurement (for P, Q, V, I) to be provided
  - The use of black-box type representation is not preferred.
  - Models should be suitable for an integration time step between 1ms and 10ms, and suitable for operation up-to and in excess of 100s.
4. Wind Turbine datasheet
  5. Voltage/reactive control strategy of farm, reactive capability curves at the point of interconnection (Temperature and Voltage dependence)
  6. Settings from a wind turbine (each model in the farm)
    - Mapping of settings from a wind turbine to the corresponding model (both UDM and generic)
  7. Settings from the Power plant controller (PPC)
    - Mapping of settings from PPC to the corresponding model (UDM and Generic model)
  8. Disturbance recordings – of wind farm response to grid disturbance together with any associated information about the circumstances of the disturbance

**3.1 Generic models in PSS/E for different technologies of Wind Turbines**

| Wind Turbine type | Technology   | Generic model                   | Model Description  |
|-------------------|--|---------------------------------|--|
| Type-1            | Direct connected (squirrel cage) induction generator (SCIG)<br><br>a) Fixed Speed Stall Control<br>b) Fixed Speed Active Control | WT1G1                           | Generator model (conventional induction generator)                   |
|                   |  | WT2T1                           | Drive train model (two-mass drive train model)                       |
|                   |  | wt1p_b                          | Pitch controller ( <i>Use only for Type 1 with active stall</i> )    |
| Type-2            | Wound rotor induction generator (WRIG) with a variable resistor in the rotor circuit, and typically employs pitch control        | WT2G1                           | Generator model (induction generator with external rotor resistance) |
|                   |  | WT2E1                           | External resistance controller                                       |
|                   |  | WT12T1                          | Drive train model  |
|                   |  | wt1p_b (no equivalent in PSS/E) | Pitch controller   |
| Type-3            | Doubly fed induction generator (DFIG) wind turbines ; Variable speed with rotor side converter                                   | REGCA1                          | Renewable energy generator converter model                           |
|                   |  | REECA1                          | Renewable energy controls model                                      |
|                   |  | WTDTA1                          | Drive train model  |
|                   |  | WTARA                           | Wind turbine aerodynamic model                                       |
|                   |  | WTPTA1                          | Simplified pitch controller model                                    |
|                   |  | WTTQA1                          | Wind generator torque control  |
|                   |  | REPCTA1                         | Renewable energy plant controller                                    |
| Type-4            | Full converter wind turbine<br><br>Generator types:<br>a) Synchronous<br>b) Permanent Magnet type                                | REGCA1                          | Renewable energy generator converter model                           |
|                   |  | REECA1                          | Renewable energy controls model                                      |
|                   |  | WTDTA1                          | Drive train model  |
|                   |  | REPCA1                          | Renewable energy plant controller                                    |
| Storage           | Utility Scale Battery Energy Storage System (BESS)   | REECCU1                         | Electrical Control Model<br>(To be used alongwith REGCA1 and REPCA1) |

- Detailed block diagrams are enclosed at Annexure



Annexure: Formats for submission of modelling data for wind turbine generators / wind farms

**Version History:**

| Version no. | Release Date | Prepared by* | Checked/Issued by* | Changes |
|-------------|--------------|--------------|--------------------|---------|
|             |              |              |                    |         |

\*Mention Designation and Contact Details

**Details submitted:**

**Details pending:**

**Details of models in PSS/E for modelling Wind plants / farms / parks:**

| Category                  | Parameter Description  | Data |
|---------------------------|--|------|
| Generator Nameplate       | Connection point voltage (kV)  |      |
|                           | Terminal voltage (kV)  |      |
|                           | Wind Farm - Rated active power (sent out) in MW  |      |
|                           | Turbine – Rated MVA  |      |
|                           | Turbine – Rated active power (P <sub>MAX</sub> ) in MW   |      |
|                           | Number of wind turbines (Type wise)  |      |
| Reactive power capability | Capability chart at connection point [If not available, then for each individual wind turbine, and mode of operation of Power Plant Controller]  | -    |
|                           | Q <sub>MAX</sub>   |      |
|                           | Q <sub>MIN</sub>   |      |
| Single Line Diagram       | Single line diagram of the wind farm/park showing number and location of turbines, cable run, transformers, feeders (including type of cables and electrical R,X,B parameters), and connection to transmission system<br>Preferable : Electrical Single Line Diagram including details between individual WTGs and b/w WTGs and aggregation points |      |
| Wind Turbine Details      | Manufacturer and product details (include Year of Manufacture)   |      |
|                           | Year of commissioning  |      |
|                           | Fixed speed or variable speed  |      |
|                           | Type of turbine: stall control, pitch control, active stall control, limited variable speed, variable speed with partial or full-scale frequency converter   |      |
|                           | Hub height (in metre)  |      |
|                           | Rotor diameter (in metre)  |      |
|                           | Number of blades   |      |
|                           | Rotor speed (in rpm)   |      |
| Gearbox ratio             |  |      |
| Generator                 | Type of generator: Type 1/ Type 2 / Type 3 / Type 4  |      |
|                           | Number of pole pairs   |      |
|                           | Stator resistance (in Ohms)  |      |
|                           | Rotor resistance (in Ohms)   |      |
| Speed control             | Details of speed controller in wind turbine  |      |
|                           | Efficiency (C <sub>p</sub> ) curves  |      |
|                           | Cut-in wind speed  |      |
|                           | Wind speed at which full power is attained Cut-out wind speed  |      |
|                           | Pitch angle at low wind speed  |      |

## Guideline for exchange of data for modelling Wind farms



| Category                             | Parameter Description   | Data |
|--------------------------------------|---|------|
| Reticulation System                  | Voltage of the reticulation system  |      |
|                                      | Number of feeders   |      |
|                                      | Cable schedules (lengths, cable size, conductor material, rating info)  |      |
| Turbine Transformer                  | Details of the turbine transformer, including vector group, impedance, and number of taps, tap position, tap ratio                      |      |
|                                      | Nameplate details   |      |
| Wind-farm Step-up transformer        | Details of the main wind farm step up transformer, including vector group, impedance, and tap position                                  |      |
|                                      | Nameplate ; OLTC?   |      |
|                                      | Controlled bus  |      |
|                                      | Voltage setpoint  |      |
|                                      | Dead band   |      |
|                                      | Number of taps  |      |
| Connection Details                   | Tap ratio range   |      |
|                                      | Voltage influence (maximum change etc)  |      |
|                                      | Short circuit ratio (SCR)   |      |
|                                      | · Min   |      |
|                                      | · Max   |      |
|                                      | Harmonic filters  |      |
|                                      | STATCOM   |      |
| Synchronous condensers               |   |      |
| Power Plant Controller (PPC) Details | Battery Energy Storage System (if applicable)   |      |
|                                      | Does the wind farm have a PPC? If yes, whether PPC controls all or part of the WTGs in wind farm  |      |
|                                      | What is the method of control – voltage regulation, power factor control, reactive power control?                                       |      |
|                                      | Voltage control strategy (operating mode)<br>- Controls MV Bus<br>- Controls HV Bus<br>- PF control<br>- Q control<br>- Voltage control |      |
|                                      | Is there a droop setting?<br>- Voltage control<br>- Frequency Control<br>- Is there line drop compensation?                             |      |
|                                      | Is reactive power limited?  |      |
|                                      | Temperature dependency  |      |
|                                      | Active power ramp rate limiters   |      |
|                                      | FRT protocols and setpoints<br>- LVRT<br>- HVRT   |      |
| Provide settings from controller.    |   |      |

**3.3 Generic Models for Type-1 and Type-2 Wind turbine generators:**

| Category  | Parameter Description   | Data |
|---|---|------|
| <b>GENERATOR model</b>  |   |      |
| Generator :<br>Type-1<br>(WT1G1)  | Synchronous reactance (ohms or pu) $X_s$  |      |
|   | Transient reactance (ohms or pu) $X'$   |      |
|   | Wound rotor induction generator (WRIG) with a variable resistor in the rotor circuit, and typically employs pitch control |      |
|   | Leakage reactance, $X_L$  |      |
|   | Saturation curve (E1, S(E1), E2, S(E2))   |      |
| Generator :<br>Type-2<br>(WT2G1)  | $X_A$ , stator reactance (pu)   |      |
|   | Doubly fed induction generator (DFIG) wind turbines ; Variable speed with rotor side converter                            |      |
|   | $X_1$ rotor reactance (pu)  |      |
|   | R_Rot_Mach, rotor resistance (pu)   |      |
|   | R_Rot_Max ( sum of R_Rot_Mach + total external resistance) in pu  |      |
|   | Saturation curve (E1, S(E1), E2, S(E2))   |      |
|   | Power – slip curve (Top 5 points in the T-s curve)  |      |
| <b>Electrical Control model</b>   |   |      |
| Rotor<br>Resistance<br>Control :<br>Type-2<br>(WT2E1)                                     | TsP, rotor speed filter time constant, sec.   |      |
|   | Tpe, power filter time constant, sec.   |      |
|   | Ti, PI-controller integrator time constant, sec.  |      |
|   | Kp, PI-controller proportional gain, pu   |      |
|   | ROTRV_MAX, Output MAX limit   |      |
|   | ROTRV_MIN, Output MIN limit   |      |
| <b>Drive Train model</b>  |   |      |
| Two-Mass<br>Turbine<br>Model for<br>Type 1 and<br>Type 2 Wind<br>Generators :<br>(WT12T1) | H, Total inertia constant, sec  |      |
|   | DAMP, Machine damping factor, pu P/pu speed   |      |
|   | Htfrac, Turbine inertia fraction (Hturb/H)1   |      |
|   | Freq1, First shaft torsional resonant frequency, Hz   |      |
|   | Dshaft, Shaft damping factor (pu)   |      |

**3.4 Generic Models for Type-3 and Type-4 Wind turbine generators:**

| Category   | Parameter Description   | Data |
|--|---|------|
| <b>GENERATOR model</b>   |   |      |
| Type-3 or Type-4<br>(REGCA1)   | Tg, Converter time constant (s)   |      |
|  | Rrpwr, Low Voltage Power Logic (LVPL) ramp rate limit (pu/s)  |      |
|  | Wound rotor induction generator (WRIG) with a variable resistor in the rotor circuit, and typically employs pitch control |      |
|  | Zerox, LVPL characteristic voltage 1 (pu)   |      |
|  | Lvpl1, LVPL gain (pu)   |      |
|  | Volim, Voltage limit (pu) for high voltage reactive current manage-   |      |
|  | Doubly fed induction generator (DFIG) wind turbines ; Variable speed with rotor side converter                            |      |
|  | Lvpnt1, High voltage point for low voltage active current manage-   |      |
|  | ment (pu)   |      |
|  | Lvpnt0, Low voltage point for low voltage active current manage-  |      |
|  | ment (pu)   |      |
|  | Iolim, Current limit (pu) for high voltage reactive current manage-   |      |
|  | ment (specified as a negative value)  |      |
|  | Tfltr, Voltage filter time constant for low voltage active current man-   |      |
|  | agement (s)   |      |
|  | Khv, Overvoltage compensation gain used in the high voltage reac-   |      |
| tive current management  |   |      |
| Iqrmax, Upper limit on rate of change for reactive current (pu)                  |   |      |
| Iqrmin, Lower limit on rate of change for reactive current (pu)                  |   |      |
| Accel, acceleration factor ( $0 < \text{Accel} \leq 1$ )                         |   |      |
| <b>Electrical Control model</b>  |   |      |
| Type-3 and Type-4<br>Wind turbines :<br>(RECA1)<br><br>[Refer Block<br>Diagrams] | Vdip (pu), low voltage threshold to activate reactive current injection logic   |      |
|  | Vup (pu), Voltage above which reactive current injection logic is activated   |      |
|  | Trv (s), Voltage filter time constant   |      |
|  | dbd1 (pu), Voltage error dead band lower threshold ( $\leq 0$ )   |      |
|  | dbd2 (pu), Voltage error dead band upper threshold ( $\geq 0$ )   |      |
|  | Kqv (pu), Reactive current injection gain during over and undervoltage conditions   |      |
|  | Iqh1 (pu), Upper limit on reactive current injection Iqinj  |      |
|  | Iql1 (pu), Lower limit on reactive current injection Iqinj  |      |
|  | Vref0 (pu), User defined reference (if 0, model initializes it to initial terminal voltage)                               |      |
|  | Iqfrz (pu), Value at which Iqinj is held for Thld seconds following a voltage dip if Thld > 0                             |      |

| Category   | Parameter Description  | Data |
|--|--|------|
| <b>Electrical Control model</b>  |  |      |
| Type-3 and Type-4<br>Wind turbines :<br>(REECA1)<br><br>[Refer Block<br>Diagrams]      | Thld (s), Time for which $I_{qinj}$ is held at $I_{qfrz}$ after voltage dip returns to zero (see Note 1)                               |      |
|  | Thld2 (s) ( $\geq 0$ ), Time for which the active current limit (IPMAX) is held at the faulted value after voltage dip returns to zero |      |
|  | Tp (s), Filter time constant for electrical power  |      |
|  | QMax (pu), limit for reactive power regulator  |      |
|  | QMin (pu) limit for reactive power regulator   |      |
|  | VMAX (pu), Max. limit for voltage control  |      |
|  | VMIN (pu), Min. limit for voltage control  |      |
|  | Kqp (pu), Reactive power regulator proportional gain   |      |
|  | Kqi (pu), Reactive power regulator integral gain   |      |
|  | Kvp (pu), Voltage regulator proportional gain  |      |
|  | Kvi (pu), Voltage regulator integral gain  |      |
|  | Vbias (pu), User-defined bias (normally 0)   |      |
|  | Tiq (s), Time constant on delay s4   |      |
|  | dPmax (pu/s) ( $>0$ ) Power reference max. ramp rate   |      |
|  | dPmin (pu/s) ( $<0$ ) Power reference min. ramp rate   |      |
|  | PMAX (pu), Max. power limit  |      |
|  | PMIN (pu), Min. power limit  |      |
|  | Imax (pu), Maximum limit on total converter current  |      |
|  | Tpord (s), Power filter time constant  |      |
|  | VQ-IQ characteristic (at least two pairs, up to 4 pairs of voltage and current in pu)  |      |
| VP-IP characteristic (at least two pairs, up to 4 pairs, of voltage and current in pu) | [Refer Block Diagrams]   |      |
| Is turbine in PF control or Q control (including controlled by external signal)?       |  |      |
| Is the turbine controlling voltage (directly, not than through PPC)?                   |  |      |
| If controlling voltage directly what bus does it control?                              |  |      |
| Is the turbine in P or Q priority mode?  |  |      |
| <b>Drive Train model</b>   |  |      |
|  | H, Total inertia constant, sec   |      |
|  | DAMP, Machine damping factor, pu P/pu speed  |      |
|  | Hfrac, Turbine inertia fraction ( $H_{turb}/H$ )1  |      |
|  | Freq1, First shaft torsional resonant frequency, Hz  |      |
|  | Dshaft, Shaft damping factor (pu)  |      |

| Category  | Parameter Description                                | Data |
|---|--|------|
| <b>Pitch Control model [for Type-3 only]</b>                  |  |      |
| Generic Pitch Control model for Type-3 : (WTPA1)              | Kiw, Pitch-control Integral Gain (pu)                |      |
|   | Kpw, Pitch-control proportional gain (pu)            |      |
|   | Kic, Pitch-compensation integral gain (pu)           |      |
|   | Kpc, Pitch-compensation proportional gain (pu)       |      |
|   | Kcc, Gain (pu)                                       |      |
|   | Tp, Blade response time constant (s)                 |      |
|   | TetaMax, Maximum pitch angle (degrees)               |      |
|   | TetaMin, Minimum pitch angle (degrees)               |      |
|   | RTetaMax, Maximum pitch angle rate (degrees/s)       |      |
|   | RTetaMin, Minimum pitch angle rate (degrees/s) (< 0) |      |
| <b>Aerodynamic model [For Type-3 only]</b>                    |  |      |
| (WTARA1)  | Ka, Aerodynamic gain factor (pu/degrees)             |      |
|   | Theta 0 Initial pitch angle (degrees)                |      |
| <b>Torque Controller model [For Type-3 only]</b>              |  |      |
| Generic Torque Controller for Type-3 wind machines : (WTTQA1) | Kpp, Proportional gain in torque regulator (pu)      |      |
|   | KIP, Integrator gain in torque regulator (pu)        |      |
|   | Tp, Electrical power filter time constant (s)        |      |
|   | Twref, Speed-reference time constant (s)             |      |
|   | Temax, Max limit in torque regulator (pu)            |      |
|   | Temin, Min limit in torque regulator (pu)            |      |
|   | p1, power (pu)                                       |      |
|   | spd1, shaft speed for power p1 (pu)                  |      |
|   | p2, power (pu)                                       |      |
|   | spd2, shaft speed for power p2 (pu)                  |      |
|   | p3, power (pu)                                       |      |
|   | spd3, shaft speed for power p3 (pu)                  |      |
|   | p4, power (pu)                                       |      |
|   | spd4, shaft speed for power p3 (pu)                  |      |
| TRATE, Total turbine rating (MW)                              |  |      |

| Category   | Parameter Description  | Data |
|--|--|------|
| <b>Power Plant Controller (PPC) model</b>  |  |      |
| Generic Power Plant Controller (PPC) model for Type-3 and Type-4 wind turbines :<br>REPCTA1 for type 3, and REPCA1 for type 4 turbines | Tfltr, Voltage or reactive power measurement filter time constant (s)  |      |
|  | Kp, Reactive power PI control proportional gain (pu)                   |      |
|  | Ki, Reactive power PI control integral gain (pu)                       |      |
|  | Tft, Lead time constant (s)  |      |
|  | Tfv, Lag time constant (s)   |      |
|  | Vfrz, Voltage below which State s2 is frozen (pu)                      |      |
|  | Rc, Line drop compensation resistance (pu)                             |      |
|  | Xc, Line drop compensation reactance (pu)                              |      |
|  | Kc, Reactive current compensation gain (pu)                            |      |
|  | emax, upper limit on deadband output (pu)                              |      |
|  | emin, lower limit on deadband output (pu)                              |      |
|  | dbd1, lower threshold for reactive power control deadband ( $\leq 0$ ) |      |
|  | dbd2, upper threshold for reactive power control deadband ( $\geq 0$ ) |      |
|  | Qmax, Upper limit on output of V/Q control (pu)                        |      |
|  | Qmin, Lower limit on output of V/Q control (pu)                        |      |
|  | Kpg, Proportional gain for power control (pu)                          |      |
|  | Kig, Proportional gain for power control (pu)                          |      |
|  | Tp, Real power measurement filter time constant (s)                    |      |
|  | fdbd1, Deadband for frequency control, lower threshold ( $\leq 0$ )    |      |
|  | Fdbd2, Deadband for frequency control, upper threshold ( $\geq 0$ )    |      |
|  | femax, frequency error upper limit (pu)                                |      |
|  | femin, frequency error lower limit (pu)                                |      |
|  | Pmax, upper limit on power reference (pu)                              |      |
|  | Pmin, lower limit on power reference (pu)                              |      |
| Tg, Power Controller lag time constant (s)   |  |      |
| Ddn, droop for over-frequency conditions (pu)  |  |      |
| Dup, droop for under-frequency conditions (pu)   |  |      |

| Category  | Parameter Description   | Data |
|---|---|------|
| <b>Electrical Control model : BESS</b>                            |   |      |
| Generic Electrical Control model for Utility Scale BESS: (RECCU1) | Vdip (pu), low voltage threshold to activate reactive current injection logic               |      |
|   | Vup (pu), Voltage above which reactive current injection logic is activated                 |      |
|   | Trv (s), Voltage filter time constant   |      |
|   | dbd1 (pu), Voltage error dead band lower threshold ( $\leq 0$ )                             |      |
|   | dbd2 (pu), Voltage error dead band upper threshold ( $\geq 0$ )                             |      |
|   | Kqv (pu), Reactive current injection gain during over and undervoltage conditions           |      |
|   | Iqh1 (pu), Upper limit on reactive current injection Iqinj                                  |      |
|   | Iql1 (pu), Lower limit on reactive current injection Iqinj                                  |      |
|   | Vref0 (pu), User defined reference (if 0, model initializes it to initial terminal voltage) |      |
|   | Tp (s), Filter time constant for electrical power   |      |
|   | QMax (pu), limit for reactive power regulator   |      |
|   | QMin (pu) limit for reactive power regulator  |      |
|   | VMAX (pu), Max. limit for voltage control   |      |
|   | VMIN (pu), Min. limit for voltage control   |      |
|   | Kqp (pu), Reactive power regulator proportional gain  |      |
|   | Kqi (pu), Reactive power regulator integral gain  |      |
|   | Kvp (pu), Voltage regulator proportional gain   |      |
|   | Kvi (pu), Voltage regulator integral gain   |      |
|   | Tiq (s), Time constant on delay s4  |      |
|   | dPmax (pu/s) ( $>0$ ) Power reference max. ramp rate  |      |
|   | dPmin (pu/s) ( $<0$ ) Power reference min. ramp rate  |      |
|   | PMAX (pu), Max. power limit   |      |
|   | PMIN (pu), Min. power limit   |      |
|   | Imax (pu), Maximum limit on total converter current   |      |
|   | Tpord (s), Power filter time constant   |      |
|   | Vq and Iq curve (Reactive Power V-I pair in p.u.) : 4 points                                |      |
|   | Vp and Ip curve (Active Power V-I pair in p.u.) : 4 points                                  |      |
|   | T, battery discharge time (s) ( $<0$ )  |      |
| SOCini (pu), Initial state of charge                              |   |      |
| SOCmax (pu), Maximum allowable state of charge                    |   |      |
| SOCmin (pu), Minimum allowable state of charge                    |   |      |

**Note:** SOCini represents the initial state of charge on the battery and is a user entered value. This is entered in pu; with 1 pu meaning that the batter is fully charged and 0 means the battery is completely discharged

### Block Diagrams

#### A. Generators:

- REGCA1: Generic Model for Type-3 and Type-4 wind turbines

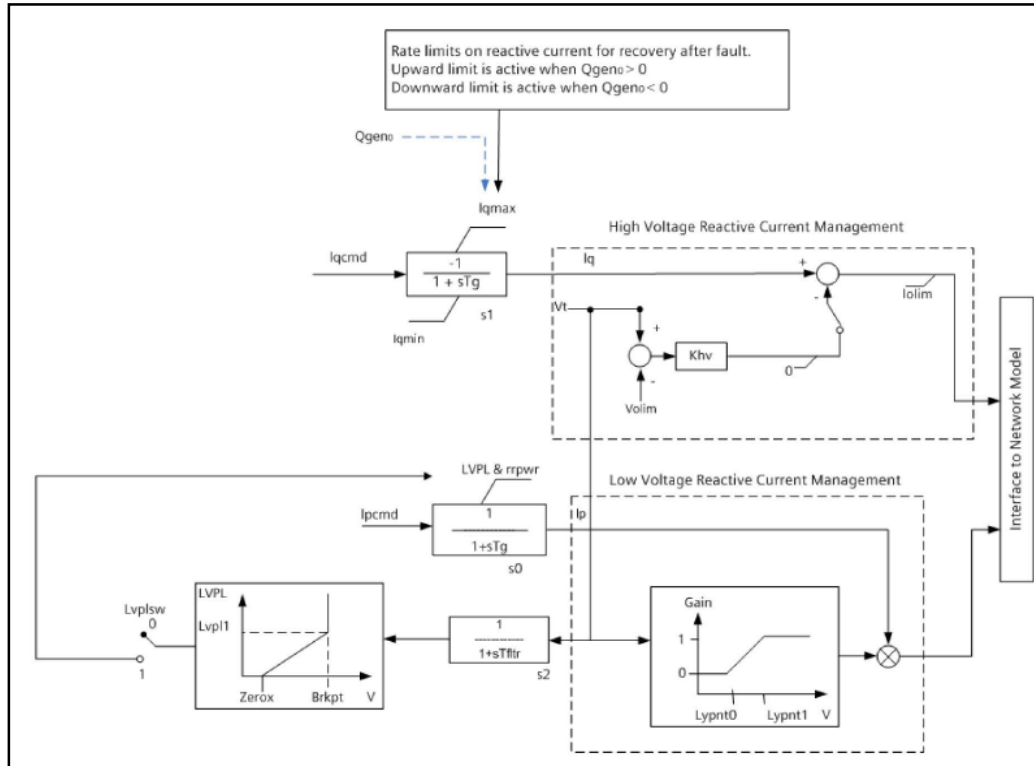

#### B. Electrical Control:

- Type-2 (WT2E1) : Rotor Resistance Control

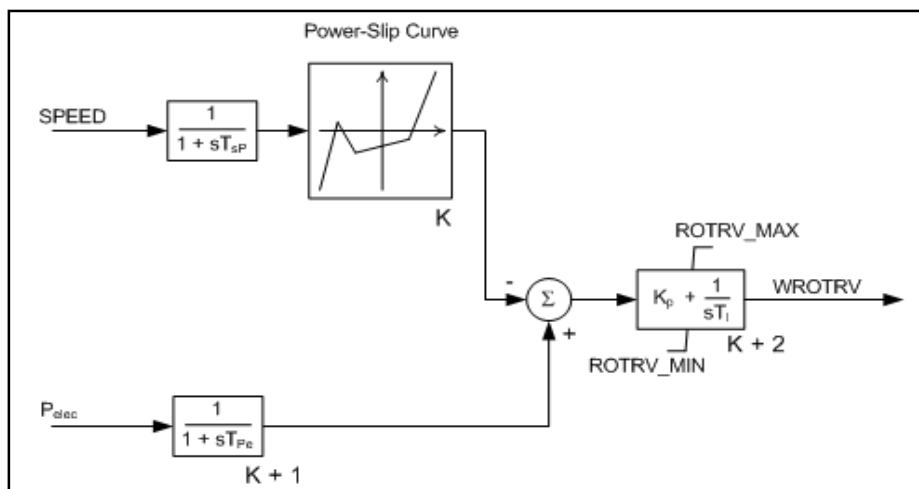



**C. Drive Train Model:**

- Type-2 (WT12T1) : For Type 1 and Type-2 wind turbines

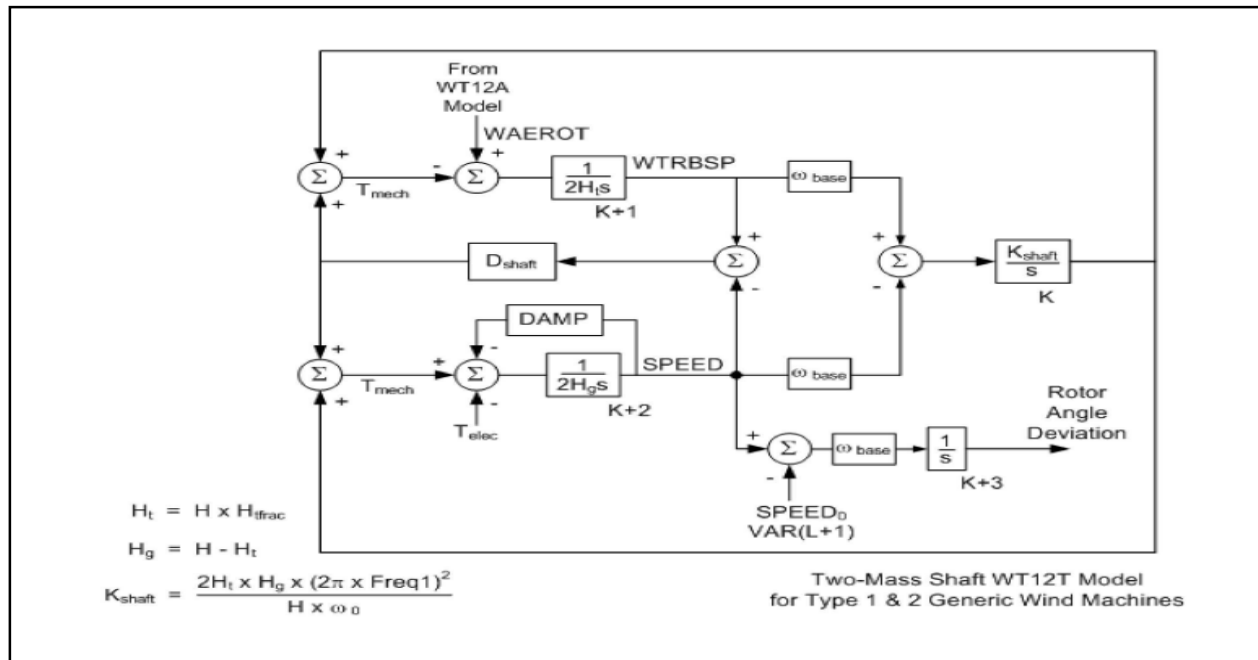

- WTDTA1 : Generic Drive Train model for Type-3 and Type-4 turbines

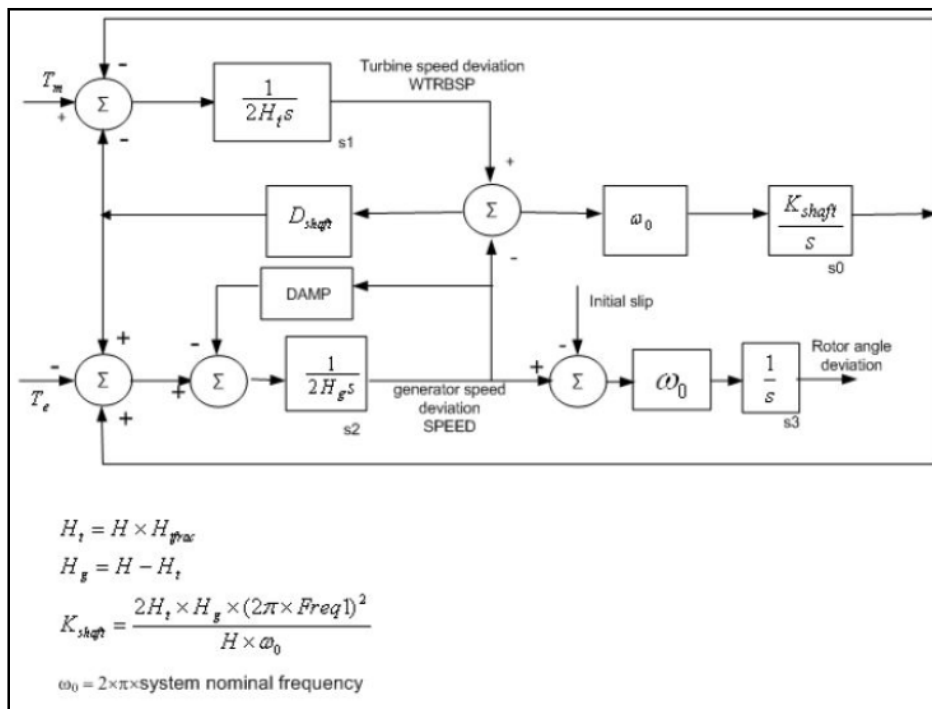

**D. Pitch Control:**

- Type-3 (WTPTA1) : Generic Pitch Control for Type-3 WTG

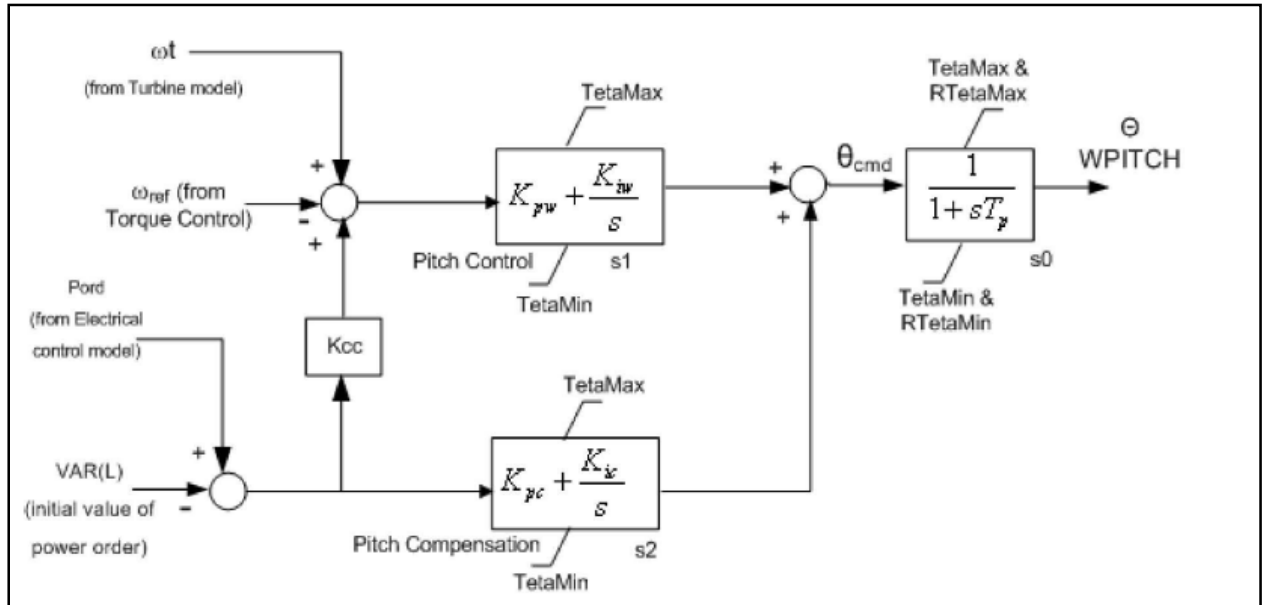

**E. Torque Controller Model:**

- Type-3 (WTTQA1) : Generic Torque Controller for Type-3 WTG

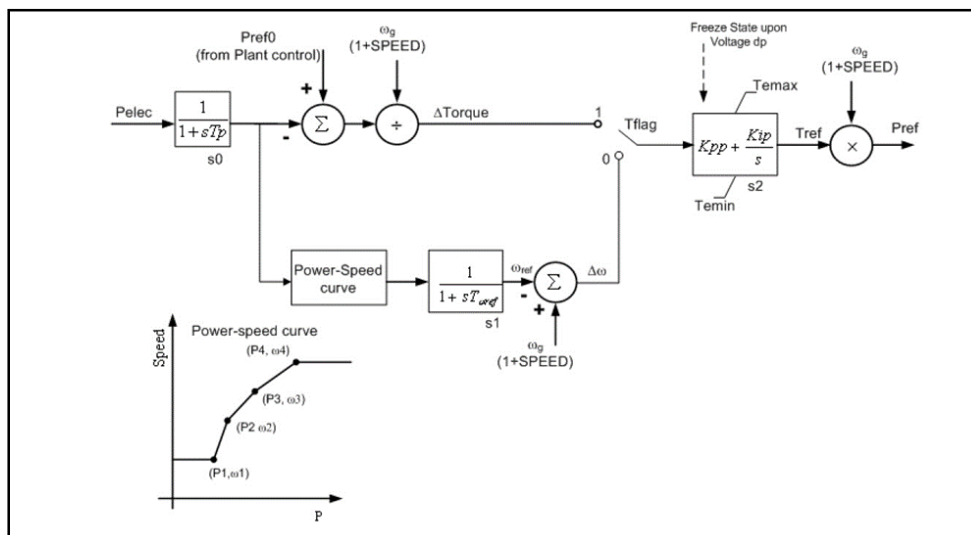

**F. Aerodynamic Model:**

- Type-3 (WTARA1) : Generic Aerodynamic model Type-3 WTG

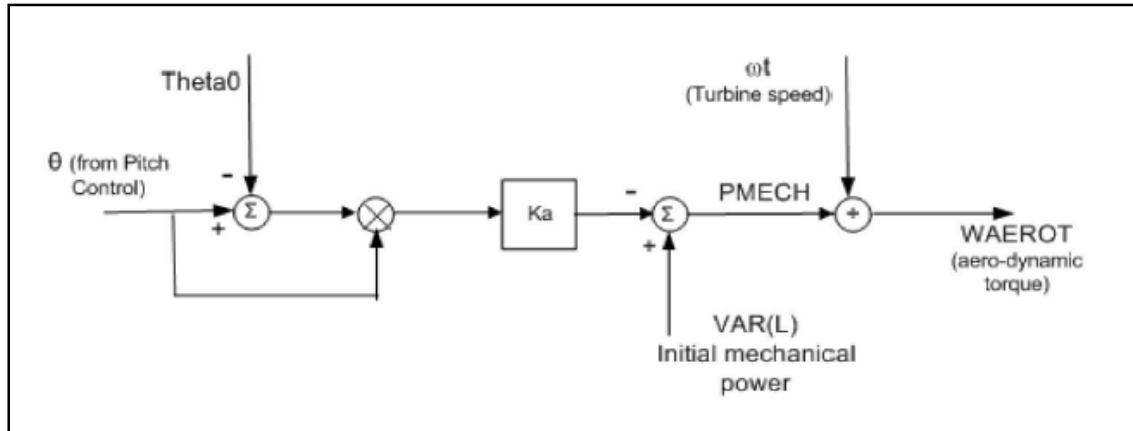

**G. Power Plant Controller (PPC) Model:**

- REPCTA1 for type 3, and REPCA1 for type 4 turbines

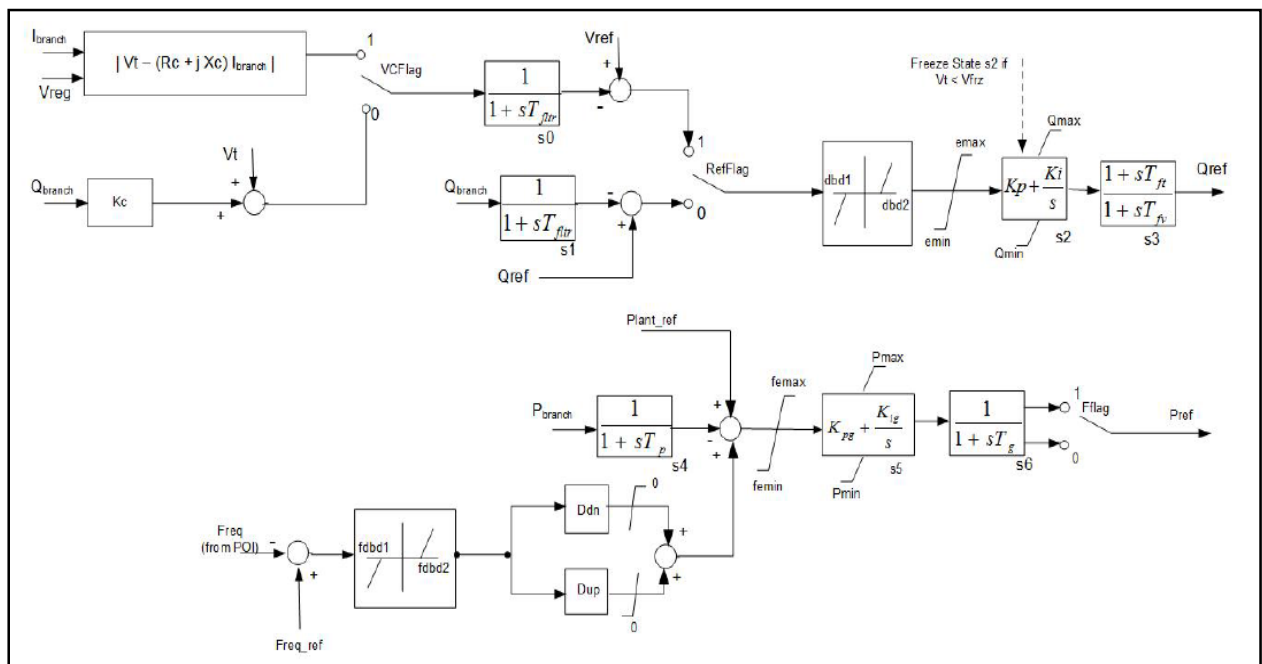

**H. Electrical Control Model for Utility Scale Battery Energy Storage System (BESS):**

