

MINUTES OF THE 108th OPERATION COORDINATION

SUB-COMMITTEE MEETING OF NERPC

Date : 23/04/2015 (Thursday)
Time : 10:00 hrs
Venue : "Hotel Nandan", Guwahati.

The List of Participants in the 108th OCC Meeting is attached at **Annexure - I**

Shri P.K. Mishra, Member Secretary, NERPC welcomed all the participants to the 108th OCC meeting. He mentioned that many of the agenda items were repeated continuously in many OCC meetings; hence, he requested that these issues should be discussed in thread bear and should be resolved. He also suggested that some of the critical issues could be discussed separately with concerned utility so that issues could be resolved. He also informed about the IEEMA seminar to be held on 24.04.2015 and requested all the constituents to visit the stalls and interact with them for the benefit of their organizations and NER.

Thereafter, Member Secretary requested Shri B. Lyngkhoi to take up the agenda items for discussion.

SE(O) informed that as suggested by Member Secretary, some of the long pending issues viz., FGMO/RGMO, SPS, ATC/TTC, UFRs etc., had already been discussed during the special meeting held on 06.04.2015 and many of these issues had been discussed and resolved.

A. CONFIRMATION OF MINUTES

CONFIRMATION OF MINUTES OF 107th MEETING OF OPERATION SUB-COMMITTEE OF NERPC.

The minutes of 107th meeting of Operation Sub-committee held on 21st March, 2015 at Agartala were circulated vide letter No. NERPC/SE (O)/OCC/2015/4556-4591 dated 31st March, 2015.

NLDC has made an observation & wanted to incorporate in **Item D.7 "Opening of Breaker from Agartala end"** as below:

Recorded:

NLDC stated that operating procedure has to be followed properly to prevent such incidences. They have suggested that operating procedures of both NEEPCO & Tripura be submitted to NERPC/NLDC/NERLDC so that they can check and if necessary procedures have to be reviewed. NEEPCO & Tripura agreed to furnish the procedures.

Amendment to be Recorded:

NLDC stated that operating procedure has to be followed properly to prevent such incidences. They have suggested that operating procedures of both NEEPCO & Tripura be submitted to NERPC so that they can check and if necessary procedures have to be reviewed. NEEPCO & Tripura agreed to furnish the procedures.

Further, to avoid such incidents in future, all the entities may submit their Standard Operating Procedure to NERPC/NERLDC for review.

Further, NERLDC has made an observation & wanted to incorporate in **Item D.8 "Training on Numerical Relay"** as below:

Deliberation of the Committee

NERLDC have requested SLDCs of NER to finalize detailed operating procedures for each state grid at the earliest.

Recorded:

DGM, NERLDC also informed that NPTI is proposed to conduct training in Guwahati if sufficient numbers of participants are more and they have agreed that boarding and lodging will be provided by them.

To be Recorded:

DGM, NERLDC also informed that in order to facilitate system operators of the region in appearing the certification exam in Basic Level, they have approached NPTI to conduct the training on the subject in Guwahati, which they have agreed if atleast 10 or more participants are confirmed. They have agreed that boarding & lodging will be provided on payment basis. Further, DGM, NERLDC informed that effort will be made to fund the training cost from LDC development fund as per norms.

NLDC informed that provision is available in PSDF for capacity building and requested NERPC/NERLDC to give a comprehensive proposal so that they can examine the matter.

The Sub-committee confirmed the minutes of 107th OCCM of NERPC as no other comments/observations were received from the constituents.

ITEMS FOR DISCUSSION

B.1. OPERATIONAL PERFORMANCE AND GRID DISCIPLINE DURING MARCH, 2015

As per the data made available by NERLDC, the grid performance parameters for March, 2015 are given below:

NER PERFORMANCE DURING MARCH, 2015

| States | Energy Met (MU) | | % inc(+)/dec(-) | Energy Reqr. (MU) | | % inc(+)/dec(-) |
|-------------|-----------------|------------|-----------------|-------------------|-------------|-----------------|
| | Mar-15 | Feb-15 | | Mar-15 | Feb-15 | |
| Ar. Pradesh | 47 | 51 | -8.8 | 48 | 53 | -9.4 |
| Assam | 656 | 561 | 16.9 | 688 | 588 | 16.9 |
| Manipur | 58 | 55 | 5.2 | 60 | 58 | 3.8 |
| Meghalaya | 149 | 146 | 1.5 | 181 | 170 | 6.4 |
| Mizoram | 37 | 33 | 10.9 | 38 | 35 | 8.7 |
| Nagaland | 65 | 59 | 11.6 | 67 | 60 | 11.1 |
| Tripura | 85 | 77 | 10.0 | 88 | 80 | 10.0 |
| Region | 1096 | 982 | 11.5 | 1170 | 1044 | 12.0 |

| States | Demand Met (MW) | | % inc(+)/dec(-) | Demand in (MW) | | % inc(+)/dec(-) |
|-------------|-----------------|-------------|-----------------|----------------|-------------|-----------------|
| | Mar-15 | Feb-15 | | Mar-15 | Feb-15 | |
| Ar. Pradesh | 107 | 115 | -7.0 | 120 | 130 | -7.7 |
| Assam | 1215 | 1215 | 0.0 | 1320 | 1380 | -4.3 |
| Manipur | 146 | 136 | 7.4 | 148 | 140 | 5.7 |
| Meghalaya | 343 | 316 | 8.5 | 360 | 320 | 12.5 |
| Mizoram | 81 | 88 | -8.0 | 84 | 89 | -5.6 |
| Nagaland | 128 | 120 | 6.7 | 130 | 120 | 8.3 |
| Tripura | 233 | 212 | 9.9 | 260 | 235 | 10.6 |
| Region | 2131 | 2155 | -1.1 | 2403 | 2318 | 3.7 |

REGIONAL GENERATION & INTER-REGIONAL EXCHANGE IN MU

AVERAGE FREQUENCY (Hz)

| Month----> | Mar-15 | Feb-15 |
|---|--------|--------|
| Total Generation in NER (Gross) | 813 | 713 |
| Total Central Sector Generation (Gross) | 233 | 482 |
| Total State Sector Generation (Gross) | 580 | 230 |
| Inter-Regional Energy Exchange | | |
| (a) NER-ER | 14.50 | 14.48 |
| (b) ER-NER | 342.85 | 328.52 |
| © Net Import | 328.35 | 314.04 |

| Month----> | Mar-15 | Feb-15 |
|--------------------------|-----------|-----------|
| | % of Time | % of Time |
| Below 49.9 Hz | 16.04 | 11.96 |
| Between 49.9 to 50.05 Hz | 59 | 60.11 |
| Above 50.05 Hz | 24.96 | 27.93 |
| Average | 49.99 | 50 |
| Maximum | 50.54 | 50.55 |
| Minimum | 49.52 | 49.58 |

From the above table, it is seen that energy requirement met (MU) and energy requirement of the region has increased considerably from the previous month.

The Summary of Messages issued by NERLDC for the constituents of NER for the Month of March, 2015 is given as below:

| Constituents | Deviation Violation Message | | | Zero crossing Violation Message | | |
|--------------|-----------------------------|-----------|-----------|---------------------------------|-----------|-----------|
| | Alert | Emergency | Total | Alert | Emergency | Total |
| AP | 0 | 0 | 0 | 0 | 26 | 26 |
| Assam | 5 | 26 | 31 | 0 | 18 | 18 |
| Manipur | 0 | 0 | 0 | 0 | 2 | 2 |
| Meghalaya | 0 | 1 | 1 | 0 | 1 | 1 |
| Mizoram | 0 | 0 | 0 | 0 | 25 | 25 |
| Nagaland | 0 | 6 | 6 | 0 | 22 | 22 |
| Tripura | 0 | 12 | 12 | 0 | 15 | 15 |
| AGBPP | 0 | 0 | 0 | 0 | 0 | 0 |
| AGTPP | 0 | 0 | 0 | 0 | 0 | 0 |
| RHEP | 0 | 0 | 0 | 0 | 0 | 0 |
| KOPILI | 0 | 0 | 0 | 0 | 0 | 0 |
| KHANDONG | 0 | 0 | 0 | 0 | 0 | 0 |
| KOPILI -II | 0 | 0 | 0 | 0 | 0 | 0 |
| DHEP | 0 | 0 | 0 | 0 | 0 | 0 |
| LOKTAK | 0 | 0 | 0 | 0 | 0 | 0 |
| PALATANA | 0 | 0 | 0 | 0 | 0 | 0 |

FOLLOW UP ACTION

C.1 Synchronization of Palatana Module -II/NTPC Unit #1/ATS

The Sub-committee also reviewed the status of commissioning of second unit of OTPC at Palatana, first unit of NTPC at Bongaigaon, Transmission lines of POWERGRID and substation at Azara of Assam. The status as informed by OTPC, NTPC, NEEPCO and POWERGRID is as follows:

| SN | Items | Status as given in 107 th OCC Meeting | Status as on 108 th OCC |
|----|---|---|--|
| 1 | Trial operation and CoD of Unit -II of Pallatana GBPP Station of OTPC | | CoD of Unit #II was completed on 24.03.15 |
| 2 | Trial operation and CoD of Unit -I of Bongaigoan TPS of NTPC | Expected Date for Synchronization of Unit -# I by 31 st March, 2015. COD is expected by September, 2015 | Expected Date for Synchronization of Unit -# I by 31 st May, 2015. COD is expected by November, 2015 |
| 3 | Trial operation and CoD of STG -I & II of AGTPP of NEEPCO | Metering, telemetry, machine data, Connectivity agreement completed/COD for Unit II- May/June, 2015. STG-I trial run with one boiler is March, 2015. | COD for Unit II- May/June, 2015. STG-I trial run with one boiler is May, 2015. |
| 4 | Trial operation and CoD of Monarchak GBPP of NEEPCO | Metering, telemetry, machine data, Connectivity agreement to be signed soon by Tripura. Synchronization depends upon availability of gas. | Metering, telemetry, machine data completed, Connectivity agreement to be signed soon by Tripura. Synchronization depends upon availability of gas. |
| 6 | 400KV D/C Silchar - Melriat line of PGCIL | June, 2015 | December, 2015 |

| | | | |
|---|---|---------------------|---|
| 7 | 400KV D/C Silchar - Imphal line of PGCIL | Charged on 16.03.15 | Completed & Charged on 16.03.15 at 132 kV level |
| 8 | 220KV D/C Mariani (New) - Mokokchung of PGCIL | March, 2015 | April, 2015 |
| 9 | 400KV D/C Byrnihat-Bongaigaon line of PGCIL | Completed. | Completed & Charged on 22.02.15. |

Deliberation of the Sub-Committee

GM, NERLDC informed that it has been observed that utilities informed that all parameters viz. telemetry, machine data, metering, connectivity agreement have been checked and complied before charging/connecting the new elements to the grid, but it was not so during the time when they synchronized to the grid. This is very critical and endanger to the real time operation of the grid. He mentioned that not only the above parameters, but the system protection has to be in place in all respects before charging for the first time to the grid, especially to those important elements which may affect the grid has to be ensured before synchronization.

The Sub-committee endorsed the view of NERLDC and constituents are requested to ensure that all the parameters should be in order before test charge/first time synchronization to the grid.

C.2 Details of Installations and self-certification (by STUs and CTUs) in respect of operationalisation of Under Frequency Relays (UFRs) in NER systems and additional requirement of UFR and df/dt relays:

The OCC regularly review the status of UFR based load shedding in the region. The latest status intimated during the 108th OCC meeting is given below: -

Assam, Manipur, Mizoram & Nagaland: UFRs based load shedding of 220MW & 20MW respectively have been implemented by both the States. However, UFR operation and amount of load relief reports are to be sent to NERLDC regularly. Assam & Nagaland agreed to do the needful and they have started sending regularly.

Arunachal Pradesh: EE, SLDC informed that UFRs based load shedding for 20MW have been implemented by them for all stages. Ar. Pradesh had furnished the list of feeders and stated that the report would be sent to NERLDC regularly. SE(O) requested Ar. Pradesh to inform the quantum of load relief in each UFR.

Meghalaya: UFRs based load shedding for Stages I, II & III completed. 4th stage implementation process is held up due to law and order problem in Garo Hills. Reports of UFR operations would be sent regularly to NERLDC.

Tripura: UFRs based load shedding for Stages I & II have been implemented. Tendering is done for Stages III & IV and M/s Alstom is awarded for implementation. It is expected to implement Stages III & IV by May, 2015.

Deliberation of the Sub-Committee

SE(O) informed that as per guidelines by CEA it is mandatory to inspect at least one third of UFRs in the region during the year. In view of the above, inspection will be carried out in the month of May/June, 2015. The itinerary would be intimated in due course. The complete UFR list is attached at **Annexure – C.2**

The sub-committee noted as above.

C.3 CT Ratio of Transmission Lines & Loadability in NER:

During 107th OCC meeting, DGM, NERLDC informed that the list of feeders for enhancement of loadability and present CT ratio available with them is given at **Annexure – C.3**. He requested constituents to check the list and update the status pertaining to them and also to intimate about the terminal equipments if the load could carry as per the CT ratio.

Further, DGM, NERLDC informed that now the loadability has to be complied as per the operational guidelines issued by NRCE, of CEA. He requested all the constituents to go through this guideline and give their comments in the next OCC meeting. The NRCE guideline is circulated along with Agenda of OCC.

Deliberation of the Sub-Committee

DGM (AM), NERTS stated that in order to comply to NRCE guidelines, constituents have to carry out patrolling on all lines and check the jumpers by using thermo vision instrument and also the terminal end equipments to find out whether the lines could carry the load as per the above guidelines.

After detailed deliberation, the Sub-committee has directed all the constituents to declare the loadability of all the lines pertaining to them and the data should be furnished to NERLDC/NERPC latest by 31.05.2015. Till submission of these data to NERLDC, NERLDC would use load-ability data as per prevailing practice.

C.4 Single Line Diagram of Sub-stations, Switching Stations & Power Stations of NER:

POWERGRID, OTPC, NHPC (**only Loktak**), NTPC & DoP, Arunachal Pradesh, MSPCL, P&E, Mizoram, MePTCL (**partially**), DoP, Nagaland, TSECL (**partially**) & NEEPCO (**partially**) have furnished.

Single Line Diagrams of some of the nodes of AEGCL have been collected from DPR for rectification of Protection System.

NEEPCO (**Khandong, Khupi & RHEP**), NHPC (**Lower Subansiri**), AEGCL (**Bihaiting, BRPL, Ghoramari, HPC-Jagiroad, HPC-Panchgram, Star Cement & CALCOM**), MePTCL (**Adhunik Cement, CMCL, Hill Cement, Leshka, Nalari, Sai Prakash & Sonapani**), and TSECL (**Gumti, Jatanbari & 132 kV Rabindranagar**) are requested to furnish Single Line Diagram of nodes as these diagrams are required for system studies, outage coordination etc.

Deliberation of the Sub-Committee

SE(O) informed that Single Line Diagrams of Lower Subansiri of NHPC has been received and the same will be forwarded to NERLDC. Further, he informed that in case of Sonapani the SLD can be deleted as it has crossed 100 years.

The Sub-committee requested NERPC to write to all concerned constituents to furnish the information pertaining to them as per list mentioned.

C.5 Finalization of Annual Load Generation Balanced Report (LGBR) for peak as well as off-peak scenarios and the Annual outage plan for 2015-2016 by 31.12.2014 as per IEGC:

As per IEGC, each SLDC shall submit LGBR for its control area, for peak as well as off-peak scenario, by 31st October for the next financial year, to respective RPC Secretariat. The annual plans for managing deficits/surpluses in respective control areas shall clearly be indicated in the LGBR submitted by SLDCs.

As per IEGC, all SEBs/STUs, Transmission Licensees, CTU, ISGS, IPPs, MPPs and other generating stations should provide to the respective RPC Secretariat their proposed outage plan in writing for the next financial year by 31st October of each year. These shall contain identification of each generating unit/transmission line/ICT etc., the preferred date for each outage and its duration and where there is flexibility, the earliest start date and latest finishing date.

Deliberation of the Sub-Committee

EE (O), NERPC informed that LGBR for 2015-2016 has already been finalized by NERPC.

SE(O) requested all the constituents to furnish the maintenance schedule for full FY of all the transmission and generating units as the same has to be sent to CEA. Constituents agreed to furnish soon.

The sub-committee noted as above.

C.6 Latest status of FGMO/RGMO implementation in different generating stations:

During 107th OCC meeting, DGM, NERLDC stated that this issue has been discussed many times in the meeting but there was no fruitful outcome. He requested NERPC to look into the matter so that the issue could be resolved at the earliest.

The Sub-committee has requested NERPC to invite the concerned member from Generating Utilities in the next OCC meeting for finalization of the issue.

Accordingly, the special meeting was conducted by NERPC on 06.04.2015 at Shillong and the issues of FGMO/RGMO, SPS etc., had been discussed in thread bear. The minute was already issued.

Deliberation of the Sub-Committee

Sr. Manager, NEEPCO informed that FGMO/RGMO as recorded in the Annexure – A will be reviewed by them once again before filing petition to CERC. The status will be intimated to NERPC/NERLDC at the earliest.

SE(O) requested Assam & Meghalaya to file petition to CERC pertaining to their generating units as decided in the sub-committee meeting of NERPC.

The Sub-committee noted as above.

C.7 Submission of list of feeders connected to essential load:

As per clause no 5.8.c of IEGC, essential loads are to be restored on priority during restoration process.

AEGCL, Me. PTCL & TSECL have only furnished the list. All other states utilities of NER are requested to furnish list of feeders connected to essential load at the earliest.

Deliberation of the Sub-Committee

The sub-committee requested NERPC to write to Ar. Pradesh, Manipur, Mizoram & Nagaland to furnish the information before the next OCC meeting.

C.8 Progress Report of Ongoing Project:

Progress reports of ongoing generation and transmission projects of NER need to be communicated to NERLDC/NERPC by all constituents on monthly basis as per format. The progress of different elements are necessary for incorporation in Operational Feedback and other reports as also for preparation of Base Case for system study in NER. Accordingly, constituents are requested to furnish the progress report of their elements by 10th of every month for the previous month.

SE (O) informed that as per decision of the sub-committee, NERPC vide letter dated 13.02.2015 has written to all the constituents to furnish the status of ongoing projects to NERLDC at the earliest.

NERLDC informed that information has now been received from NTPC, NEEPCO, Meghalaya, Assam & OTPC. NERLDC requested the remaining constituents to furnish the same at the earliest.

Deliberation of the Sub-Committee

SE (O) informed that as per decision of the sub-committee, NERPC vide letter dated 13.02.2015 has written to all the constituents to furnish the status of ongoing projects to NERLDC at the earliest.

NERLDC informed that information has now been received from NTPC, NEEPCO, OTPC & partly from Assam & Meghalaya. NERLDC requested the remaining constituents to furnish the same at the earliest.

Mizoram has furnished the data during the meeting.

GM, NERLDC enquired about the status of 800 kV HVDC line and the likely date of commissioning.

DGM (AM), NERTS informed that the above project is being handed by separate division and the status has to be obtained from them.

NERLDC has requested to arrange separate meeting with concerned officers of constituents for submitting of progress report of on-going projects under their jurisdiction and other related issues.

The sub-committee requested the remaining constituents viz. Ar. Pradesh, APGCL, Me. PGCL, Me. PTCL, MSPCL, TSECL, TSECL, Nagaland & POWERGRID to furnish the above information at the earliest. Constituents who do not have any ongoing projects may kindly be informed as NIL report. Further, the status of HVDC has to be intimated by concerned wing of POWERGRID in the next OCC meeting.

C.9 Formats for new unit expected to be commissioned within 2 months:

Information related to charging/first time synchronization of new elements/units is to be furnished to NERLDC (two month in advance). All the activities related to charging/first time synchronization of new elements are to be completed before charging/first time synchronization of new elements. The technical data of the elements are also necessary for preparation of Base Case for system study for NER system.

During the 107th OCC meeting, The Sub-committee requested to intimate the Nodal Officer for above issue so that correspondence could be taken up with them directly. The name of Nodal Officer is given below:

Deliberation of the Sub-Committee

The Sub-committee requested to intimate the Nodal Officer for above issue so that correspondence can be taken up with them directly. The name of Nodal Officer along with contact number is given below:

| Constituent | Name of Nodal Officer | Contact No | Email id: |
|--------------------|----------------------------|-------------|-------------------------------|
| Ar. Pradesh | N. Perme, EE, SLDC | 09436288643 | sldcitnagar@gmail.com |
| Assam | B.C. Borah, DGM, LDC | 09435119248 | sldcaseb@rediffmail.com |
| Manipur | L. Haokip, Manager | 08575004401 | l.haokip@mspdcl.com |
| Mizoram | Vanlalrema, SE, SLDC | 09436140353 | sldc_mizoram@rediffmail.com |
| Meghalaya | F.E. Kharshiing, SE, SLDC | 09612170657 | sldc.shg@gmail.com |
| | H.F. Shangpliang, EE, MRT | 09863315562 | hector_fd@rediffmail.com |
| Nagaland | Atoho Jakhalu, EE, SLDC | 09436002696 | atoho.jk@gmail.com |
| Tripura | Mrinal Pal, Manager | 09436137022 | mrinalpaulnit@gmail.com |
| NEEPCO | Bhaskar Goswami, Sr. Mgr | 09436163983 | pbhaskargoswami@yahoo.com |
| NHPC | R.C. Singh, Manager | 09436894889 | rcsloktak@yahoo.com |
| NERTS | Supriya Paul, Dy. Mgr. | 09436302995 | nerts_os@yahoo.in |
| | Deep Bhaumick, Engineer | 09436335255 | -do- |
| OTPC | Narendra Gupta, Manager | 09774233426 | nk.gupta@otpcindia.in |
| NTPC | J. Bhattacharyya, AGM(EMD) | 09435720036 | jayanbhattacharjee@ntpc.co.in |
| | G. K. Kundu, AGM(EEMG) | 09401826314 | |

Further, NERLDC has informed that protection system of the element is to be checked & rectified in case of observance of any protection deficiency before charging/first time synchronization of new elements.

The sub-committee requested NERPC to hold the special meeting comprising of nodal officers of constituents, NERLDC & NERPC at the earliest so that the issues related to first time charging of transmission element and first time synchronization of generating unit can be resolved.

C.10 Assessment of Inter State Total Transfer Capability (TTC), Transmission Reliability Margin (TRM) and Available Transfer Capability (ATC) by SLDC on respective Inter-State Transmission Corridor:

As per Clause No. 4.1 of 'Detailed Procedure for Relieving Congestion in Real Time Operation', SLDC shall assess TTC, TRM and ATC on it's inter-state transmission corridor considering a mesh intra-state corridor for import or export of power with the Inter-state Transmission system (ISTS).

SLDCs of NER were accordingly requested to assess the above on monthly basis, 5 months in advance (e.g. TTC/TRM/ATC for the month of November to be calculated by 15th of July), for further assessment of TTC, ATC and TRM of NER – ER corridor by NERLDC/NLDC and for assessment of TTC / ATC for a group of control areas, individual control areas within the region and state-control-area to state-control-area by NERLDC, whenever required.

SLDCs were also requested to send study results for Peak (Export & Import) & Off Peak (Export & Import) along with assumptions in details and 6 nos. *.sav case files (Base Case for Peak & Off Peak, Off Peak & Peak Export & Off Peak & Peak Import) to NERLDC by 15th of the month for the fifth month. All India *.sav case files have been sent to SLDCs which may be used while computing TTC, ATC & TRM for their state control area.

The latest .sav case files of Off Peak & Peak Cases have been mailed to SLDCs of NER on **5th March, 2015**.

The study results for assessment of Total Transfer Capability (TTC), Transmission Reliability Margin (TRM) and Available Transfer Capability (ATC) have not been received from any SLDC of NER.

Deliberation of the Sub-Committee

DGM (SO-II), NERLDC stated that TTC/ATC data are being assessed by them on behalf of constituents and requested them to check the data and give their comments at the earliest. TTC of states under peak & off peak scenarios assessed by NERLDC are as follows:

Import Capability

| S N | State | Off-Peak Case | | Peak Case | |
|--------|-------------------|--|---------------------------|--|---------------------------|
| | | Contingency | Total Transfer Capability | Contingency | Total Transfer Capability |
| 1 | Arunachal Pradesh | N-1 of 132 kV Rangandi - Ziro S/C | 115 | N-1 of 132 kV Rangandi - Ziro S/C | 115 |
| 2 | Assam | N-1 of 220/132 kV, 3x100 MVA transformers at Sarusajai | 1175 | N-1 of 220/132 kV, 3x100 MVA transformers at Sarusajai | 1295 |
| 3 | Manipur | N-1 of 132 kV Imphal (PG) - Imphal D/C | 260 | N-1 of 132 kV Imphal (PG) - Imphal D/C | 260 |
| 4 | Meghalaya | N-1 of 132 kV Killing-Epip II D/C | 250 | N-1 of 132 kV Killing-Epip II D/C | 250 |
| 5 | Mizoram | N-1 of 132 kV Aizawl - Zimabawk S/C | 37 | N-1 of 132 kV Aizawl - Zimabawk S/C | 37 |
| 6 | Nagaland | N-1 of 132 kV Dimapur -Kohima S/C | 95 | N-1 of 132 kV Dimapur -Kohima S/C | 95 |
| 7 | Tripura | N-1 of 132 kV Palatana - Udaipur S/C | 130 | N-1 of 132 kV Palatana - Udaipur S/C | 126 |

He also requested to send study results for Peak (Export & Import) & Off Peak (Export & Import) along with assumptions in details to NERLDC for the fifth month by 15th of the month regularly. Further, during the presentation by NERLDC data of exciter, generator, PSS, etc., has to be submitted by the constituents. The detailed parameters are given at **Annexure – C.10**.

SE(O) informed that during the meeting held on 06.04.2015, the Sub-committee recommended that engineers from SLDCs and Planning should be made mandatory to attend the SS meeting and all constituents should bring their PSS-E software laptops along with Dongle for SS meeting. Moreover, the Sub-committee requested NERPC to write to all the constituents to intimate the status and possession of the laptops issued by CTU/POSOCO so that no misuse should be allowed. Further, the officers who possess these laptops should be kept ready with them and while on transfer/promotion they should be handed over immediately to the next in-charge so that impart to training on them can be made and the name of the next officer should be intimated to NERLDC/NERPC for record.

The Sub-committee decided that after every PCC meeting system study to impart expertise will be carried out. All constituents have to bring their laptops pre-installed with PSSE software and Dongle as issued along with their system networks of their states so that training on load flow studies could be made for their benefit. NERLDC would help in imparting the training. The Sub-committee requested SLDCs of NER to nominate the officer who will do the system study of their system.

C.11 Requirement of Reactor at Balipara & Bongaigaon:

After commissioning of 400 kV Balipara – Bongaigaon III & IV lines & 400 kV Bongaigaon – New Siliguri III & IV lines, voltage trend at Ranganadi, Balipara & Bongaigaon significantly increases during off peak hours.

To contain voltage at these nodes within IEGC band, one circuit of 400 kV Balipara – Bongaigaon lines, 400 kV Bongaigaon – New Siliguri lines & 400 kV Ranganadi – Balipara lines are kept open during off peak hours.

It was agreed in 4th SCM of NER on 13.12.14 for installation of 125 MVAR Bus Reactors by POWERGRID at Balipara and Bongaigaon.

For immediate solution, Line Reactors of 400 kV Balipara - Bongaigaon I & II at Balipara & Bongaigaon are required to be converted into Bus Reactors.

Deliberation of the Sub-Committee

DGM (AM) informed that procurement for switching equipments is under progress and the status will be intimated to NERLDC/NERPC accordingly.

The Sub-committee noted as above.

C.12 Low Voltage at Manipur & Mizoram:

During 104th OCC meeting, representative from Loktak informed that low voltage still persist in Loktak sub-station and requested the forum to look into the matter.

The Sub-Committee requested NHPC to install the capacitor bank in order to arrest the low voltage.

Further, NERLDC informed that severe low voltage problem at Imphal (PG), Loktak and nodes of Manipur system has been observed during outage of 132 kV Dimapur – Imphal line or 132 kV Loktak – Jiribam line. It was informed by P&E, Mizoram that low voltage problem at nodes of Mizoram system has also been observed.

It is required to install capacitor banks in 33 kV nodes of Manipur & Mizoram system to improve voltage profile of these nodes. Study results for installation of capacitor banks at nodes of Manipur & Mizoram system are already furnished by NERLDC.

During 105th OCC meeting, NERLDC gave a presentation on the above and it can be clearly seen that very low voltage is prevailing in Aizawl, Lunglei & Loktak. They suggested that necessary capacitor bank should be installed at the earliest to maintain the voltage level as per IEGC.

After detailed deliberation, the Sub-committee requested NERPC to write to Mizoram & NHPC to change the transformer tap position accordingly and NERLDC may observe the voltage profile for one-two months and if the problem still persists, the Sub-committee may review again and find out the alternative solution.

During 106th OCC meeting, SE(O) informed that NERPC vide letter dated 13.02.2015 has already written to NHPC & Mizoram to set the tap position at the maximum.

During 107th OCC meeting, DGM (OS), NERTS informed that after charging of 132kV SIIchar- Imphal line the voltage has improved very much. The problem is with downstream only.

After detailed deliberation, the sub-committee suggested Manipur, NHPC & Mizoram to send the SCADA plot of voltage profile of 132kV/33kV node for whole day for 3-4 days to NERLDC so that further study can be made by them to resolve the issue.

Deliberation of the Sub-Committee

Mizoram informed that low voltage has been observed during last December, but the voltage level has now been improved. However, they informed that 3 Nos. of Capacitor Bank has already been procured by them and they have identified the locations to be installed i.e. Serchip, Zuangtui & Lunglei.

GM, NERLDC informed that after commissioning of Silchar- Imphal lines, the low voltage problems at Imphal, Mizoram have been mitigated to a large extent and now low voltage at 132kV is observed in Nirjuli only.

The Sub-committee noted as above.

C.13 Hourly Demand data in MW & Daily MU Requirement:

As per clause no 5.3.c of IEGC, each SLDC shall develop methodologies/mechanisms for daily/weekly/monthly/yearly demand estimation (MW, MVAR and MWH) for operational purpose.

SLDCs of NER are requested to furnish hourly demand data in MW & daily MU requirement to NERLDC in excel file by 2000 Hr on day ahead basis through nerldc@yahoo.co.in. These data are required for real time operation and preparation of reports.

Deliberation of the Committee

After detailed deliberation, the sub-committee requested all the constituents to furnish the monthly demand forecast for the whole month and NERLDC will review the day ahead demand as per the monthly report. Constituents should commence the above exercise from the month of May, 2015 onwards.

C.14 Second In-feed for NER-ER Corridor:

At present NER Grid is connected to rest of NEWS Grid through only one in-feed i.e. Bongaigaon - Salakati substation. On 23.02.15 at around 1809 Hrs due to tripping of all the outgoing feeders of 400 kV Bongaigaon substation, 220kV Salakati- BTPS D/C lines overloaded and tripped. This resulted into isolation of NER grid from the rest of NEWS Grid and subsequently major part of NER Grid collapsed.

This type of grid disturbances can be avoided if there is more than one in-feed of NER Grid with ER Grid.

At present Bongaigaon Thermal Power Plant (BgTPP) is connected with 400 kV Bongaigaon S/S through 400 kV Bongaigaon – BgTPP D/C lines. Second in-feed of NER Grid with ER Grid may be formed, albeit at the same geographical location, if one circuit each of 400 kV Bongaigaon – Binaguri lines and 400 kV Bongaigaon – Balipara lines terminated to BgTPP in place of Bongaigaon.

NERLDC pointed out that 2nd in-feed at Balipara could also be formed by connecting one circuit each of 400 kV Bongaigaon – Binaguri lines and 400 kV Bongaigaon – Balipara lines bypassing Bongaigaon S/S subject to technical feasibility.

Deliberation of the Committee

The Sub-committee decided to jointly visit by NERLDC, NERPC, NERTS and NTPC to explore the possibility of creating additional space to incorporate required number of bays for implementation of above scheme. The issue will be discussed in the next OCC meeting.

C.15 Monthly MU requirement & availability of each state of NER as per format:

The following figures of state wise MU requirement and availability were taken from LGBR 2015-16 of NERPC.

Requirement:

| Name of State | Apr15 | May15 | Jun15 | Jul15 | Aug15 |
|---------------|-------------|-------------|-------------|-------------|-------------|
| Ar. Pradesh | 66 | 70 | 67 | 67 | 72 |
| Assam | 640 | 745 | 790 | 845 | 845 |
| Manipur | 65 | 65 | 75 | 75 | 75 |
| Meghalaya | 165 | 170 | 160 | 170 | 170 |
| Mizoram | 40 | 40 | 40 | 42 | 42 |
| Nagaland | 60 | 60 | 65 | 65 | 65 |
| Tripura | 115 | 125 | 125 | 130 | 130 |
| NER | 1151 | 1275 | 1322 | 1394 | 1389 |

Availability:

| Name of State | Apr15 | May15 | Jun15 | Jul15 | Aug15 |
|---------------|-------------|-------------|-------------|-------------|-------------|
| Ar. Pradesh | 50 | 57 | 68 | 89 | 86 |
| Assam | 520 | 554 | 635 | 748 | 739 |
| Manipur | 66 | 69 | 79 | 101 | 101 |
| Meghalaya | 146 | 188 | 221 | 294 | 307 |
| Mizoram | 43 | 49 | 55 | 66 | 65 |
| Nagaland | 47 | 43 | 51 | 67 | 70 |
| Tripura | 197 | 211 | 212 | 234 | 233 |
| NER | 1069 | 1171 | 1321 | 1599 | 1601 |

- These data required for preparation of various reports.

C.16 Monthly MW requirement & availability of each state of NER:

A. Peak Demand in MW

| Name of State | Apr15 | May15 | Jun15 | Jul15 | Aug15 |
|---------------|-------------|-------------|-------------|-------------|-------------|
| Ar. Pradesh | 138 | 138 | 133 | 133 | 138 |
| Assam | 1395 | 1415 | 1440 | 1450 | 1510 |
| Manipur | 132 | 148 | 138 | 143 | 149 |
| Meghalaya | 400 | 400 | 400 | 400 | 395 |
| Mizoram | 85 | 85 | 90 | 85 | 90 |
| Nagaland | 120 | 120 | 120 | 135 | 130 |
| Tripura | 265 | 285 | 290 | 290 | 305 |
| NER | 2535 | 2591 | 2611 | 2636 | 2717 |

B. Peak Availability in MW

| Name of State | Apr15 | May15 | Jun15 | Jul15 | Aug15 |
|---------------|-------------|-------------|-------------|-------------|-------------|
| Ar. Pradesh | 115 | 138 | 143 | 148 | 143 |
| Assam | 793 | 1079 | 1179 | 1197 | 1113 |
| Manipur | 107 | 152 | 160 | 160 | 159 |
| Meghalaya | 264 | 343 | 397 | 456 | 488 |
| Mizoram | 78 | 101 | 106 | 116 | 109 |
| Nagaland | 77 | 93 | 101 | 101 | 104 |
| Tripura | 374/230 | 377/230 | 396/230 | 403/230 | 398/230 |
| NER | 2030 | 2136 | 2461 | 2555 | 2514 |

*Tripura indicates 272/230 if Pallatana available/if not available

A. Off Peak Demand in MW (0800 Hr)

| Name of State | Apr15 | May15 | Jun15 | Jul15 | Aug15 |
|---------------|-------------|-------------|-------------|-------------|-------------|
| Ar. Pradesh | 76 | 76 | 73 | 73 | 76 |
| Assam | 900 | 860 | 900 | 905 | 920 |
| Manipur | 86 | 96 | 90 | 93 | 97 |
| Meghalaya | 220 | 220 | 220 | 220 | 217 |
| Mizoram | 55 | 55 | 59 | 55 | 55 |
| Nagaland | 72 | 72 | 72 | 81 | 78 |
| Tripura | 180 | 194 | 197 | 197 | 201 |
| NER | 1461 | 1573 | 1611 | 1624 | 1644 |

B. Off Peak Availability in MW (0800 Hr)

| Name of State | Apr15 | May15 | Jun15 | Jul15 | Aug15 |
|---------------|-------------|-------------|-------------|-------------|-------------|
| Ar. Pradesh | 35 | 48 | 74 | 110 | 108 |
| Assam | 771 | 916 | 1077 | 1047 | 1047 |
| Manipur | 52 | 76 | 103 | 136 | 136 |
| Meghalaya | 204 | 254 | 321 | 423 | 440 |
| Mizoram | 50 | 64 | 75 | 92 | 100 |
| Nagaland | 45 | 56 | 71 | 96 | 95 |
| Tripura | 230 | 230 | 230 | 230 | 230 |
| NER | 1461 | 1644 | 1951 | 2134 | 2156 |

The Sub-committee noted as above.

D. NEW ITEMS

D.1 Generation Planning (ongoing and planned outages)

The availability of hydro stations of NEEPCO/NHPC are as follows:

| Generating Station | Reservoir level as on 18/03/15 | MU Content | Present DC MU | No. of days as per current generation |
|----------------------|--------------------------------|------------------------------|------------------------|---------------------------------------|
| Khandong & Kopili-II | 706.105 mts | 4.50 | 0.108+0.054 = 0.162 | |
| Kopili | 596.66 mts | (15 + 4* 6.07) = 39.28 | 0.0 | Plant under shutdown |
| Doyang | 307.65 mts | 1.3 | 0.096 | |
| Loktak | 766.78 mts | 16.3 | 0.217 | |

GM, NERLDC enquired from NEEPCO about the status of Kopili HEP.

NEEPCO informed that Kopili Unit # I & II will be restored back by 04.05.2015 and Units # III & IV will be restored by 07.05.2015. Hence by 10.05.2015 all the units will be available.

OTPC informed that PG Test for Unit #I is overdue and requested for shutdown of Unit #I from 00:00 hrs of 08.05.2015 to 24:00 hrs of 28.05.2015. Further, along with the shutdown Boiler Licence Renewal, GTG transformer and filter house will also be carried out. He requested OCC to approve the same.

The sub-committee discussed and approved the proposed shutdown of OTPC as mentioned above. However, OTPC should generate to the full capacity from unit #II. OTPC agreed.

D.2 Water level and spillage data of hydro stations

Historical data of reservoir level and spillage data of Hydro stations are not available with NERLDC. This information is sometimes asked by various authorities to facilitate in making database for the same. All concerned are requested to furnish the available information to NERLDC as early as possible.

NERLDC had sent the format to all the constituents for necessary submission of data. However, till date no constituents have submitted the data to NERLDC.

NERLDC informed that Assam, NEEPCO & NHPC has furnished the above information but not as per the format given by NERLDC.

Water level format:

| | | | | | |
|---------|-------|------|-------------|------------------|--------------------------|
| Year | | FRL | | MDDL | |
| Station | Month | Date | Water level | Generation in MU | Water utilized in cumecs |
| | | | | | |

Water spillage format:

| | | | | | | |
|------|------------------|---|-------------|-----------|-------|-------|
| Year | Station | | | | | |
| Date | Inflow in cumecs | Status of spillage (Spilling/ Not spilling) | Duration | | Total | Month |
| | | | From (Hrs.) | To (Hrs.) | Hrs. | |

Constituents informed that previous data may not be readily available with them, however, present data available will be sent shortly.

Deliberation in the meeting

Constituents informed that water utilized in cumecs is not possible to give unless special meter at tail race is installed to monitor the flow of water.

The Sub-committee requested NERLDC to write to all constituents once again with a copy to NERPC asking them to furnish the data as per data available with them to NERLDC at the earliest.

D.3 Outage Planning Transmission elements

It was agreed in the 99th OCC meeting that shutdown will be availed only after approval is given by the OCC forum. It was also agreed that deferment/revision of outages elements other than already approved in OCC will be henceforth put/displayed in the website of NERPC (under Operational Activities/OCC Approved shutdown) as per CERC regulations/ CEA guidelines etc for ensuring smooth & secure grid operation.

Furnishing request of shut down of the element, which was approved by NERPC, by Indenting Agency (ISTS licensees/STUs/Generating Companies) to NERLDC: Planned shutdown approved by NERPC shall be considered for implementation by NERLDC on D-3 basis. If an outage is to be availed on say 10th of the month, the shutdown availing agency would reconfirm to NERLDC on 7th of the month by 10:00 Hr. This practice is necessary to ensure optimal capacity utilization and the time required for associated system study/coordination by/amongst RLDC/NLDC.

Deliberation in the meeting

The sub-Committee discussed and approved the proposal received from the constituents regarding transmission elements for April - May, 2015 and the same is attached at Annexure - D.3. Also the committee has decided that no shutdown will be entertained henceforth unless discussed in OCC meeting, except on emergency basis.

D.4 Frequent Tripping of Pallatana Unit:

Sr. Mgr., TSECL informed that NERLDC is allowing sudden/intraday 2nd unit Generation to OTPC without consent of constituent in several occasions for which penalty is imposed including backing down of state Generation. Due to sudden change of schedule, huge penalty along with other applicable charges like POC, POSSOCO, Fixed charges etc has to be borne by TSECL while TSECL is no way liable for such act. Under DSM regulation balancing of schedule & actual drawal has to be strictly maintained.

Revision of schedule of respective unit may be allowed on technical ground but addition & withdrawal of unit totally without day ahead notice should be discontinued as this is causing severe commercial loss to the states. Tripura requested that no scheduling should be carried out without intimation to the constituents.

After detailed deliberation, the Sub-committee requested NERLDC to intimate to all the constituents before commencement of any revised schedule and they should also ensure that apart from sending mail for commencement, they can send instant SMS to all the heads of SLDC so that proactive action can be taken by them.

D.5 Partial Requisition Based Scheduling:

Sr. Manager, TSECL informed that Partial Requisition based schedule has been implemented in the region except for hydel Generation. But hydel generation frequently changes their schedule which is effected the DSM & penalty imposed for that especially during monsoon. Matter was discussed earlier also; hence it is requested to look into the matter for betterment of the region.

After detailed deliberation, the Sub-committee requested NERLDC to carry out the scheduling as per IEGC only.

D.6 Up-dated List of Important Grid Elements of NER May, 2015 (Draft):

NERLDC informed that as per Clause No 5.2.c of IEGC, List of Important Grid Elements of NER (May 2015 - Draft) was prepared by them and the Updated List of Important Grid Elements of NER (May 2015 - Draft) was e-mailed to regional entities of NER and also available in NERLDC website.

They requested all the constituents to furnish data required for finalization of List of Important Grid Elements (May 2015) by 8th May, 2015. This document would be finalized by 15th May, 2015.

The document is password protected. Password may be collected from SOII department of NERLDC.

Deliberation in the meeting

The Sub-committee requested all the constituents to go through the draft document which was already uploaded in NERLDC website and give their observations/comments if any.

D.7 Sharing of Inter-State Transmission Charges & Losses (Third Amendment), Regulations, 2015:

NERLDC informed that Honorable CERC had notified Sharing of Inter State Transmission Charges and Losses (Third Amendment) Regulations, 2015 on 1st April'15 which is available in NERLDC website. These regulations shall come into force with effect from 1st May'15.

As per provisions of the CERC (Sharing of Inter State Transmission Charges and Losses) (Third Amendment), Regulations, 2015, the Designated ISTS Customers (DICs) are required to submit node-wise forecast injection/withdrawal information and maximum injection/withdrawal data for corresponding quarter of last three years to the Implementing Agency for computation of PoC Charges & Losses for Q1 of 2015-16. It is requested that data may be furnished within the stipulated date.

Deliberation in the meeting

NERLDC gave a presentation in this regard and the gists of important points are highlighted as per **Annexure – D.7.**

Assam requested to send the SEM data to their SLDC so that PoC calculation can be prepared by them.

The Sub-committee requested NERLDC to arrange a workshop in this regard and also to highlight about all the recent CERC's Regulations for the benefit of the NER constituents. NERLDC agreed.

D.8 Estimated Transmission Availability Certificate (TAC) for the month of March, 2015:

NETC and NERTS, POWERGRID have submitted TAC data of March, 2015 in the first/second week of April, 2015. This will enable issuance of verification by NERLDC and certification by NERPC on monthly basis within stipulated time frame. Both NETC and NERTS are advised to follow the agreed time schedule in future to avoid accumulation of reports and corresponding delay.

D.9 Requirement of Bus reactor at Byrnihat SS:

DGM (AM) stated that as per 105th OCC meeting recordings, BHEL make 63 MVAR repaired Balipara reactor shall be brought to Byrnihat to replace the failed 63 MVAR CGL make reactor at Byrnihat SS of MePTCL. POWERGRID had already taken up the work to divert reactor to Byrnihat which may involve lot of cost implication due to transportation from Allahabad, procurement of auxiliary equipments like Bushings, radiators, bucholtz relay, PRV etc. Meanwhile 63 MVAR Line reactor commissioned at Byrnihat SS during FEB 2015. In view of the above replenishment of reactor by POWERGRID may be reviewed.

GM, NERLDC stated that a spare reactor available in the region could be utilized for the time being at Byrnihat till the faulty reactor is repaired. Moreover, since Byrnihat is one of the important sub-station in the region reactor is a must as operation of the grid to contain the voltage is necessary.

DGM (AM), NERTS informed that spare reactor is a regional property and it is kept as spare for CTU and for emergency basis only. Hence, if this only one spare reactor is utilized at Byrnihat; if any exigency occurs, they would not be in a position to

utilize it. Further, he suggested that Meghalaya may opt for repairing of the reactor at site and NERTS can help them to call some of the reputed firm so that cost-wise can be saved.

After detailed deliberation, the sub-committee requested Meghalaya to take up the matter with NERTS for above reactor repairing. Further, the sub-committee suggested to procure more spare reactors for the region and NERLDC may work out the critical locations so that exact number can be put up in the next TCC/RPC meeting.

D.10 PLCC connection:

NHPC informed that PLCC in 132 kV Loktak – Rengpang & Loktak – Ningthoukhong is not working and requested the forum to look into the matter.

Deliberation in the meeting

The Sub-committee requested NERPC to write to Manipur for making the PLCC operational.

Date & Venue of next OCC meeting

It is proposed to hold the 109th OCC meeting of NERPC on second week of May, 2015. However, the exact date and venue will be intimated in due course.

The meeting ended with thanks to the Chair.

Annexure-I

List of Participants in the 108th OCC Meetings held on 23/04/2015

| SN | Name & Designation | Organization | Contact No. |
|-----|--|--------------------|-------------|
| | No Representatives | Ar. Pradesh | |
| 1. | Sh. A.K. Saikia, DGM,LDC, AEGCL | Assam | 09401026118 |
| 2. | Sh. Karuna Sarma, AGM, AEGCL | Assam | 09435013532 |
| 3. | Sh. J. K. Baishya, AGM, AEGCL | Assam | 09854015601 |
| 4. | Sh. G.K. Bhuyan, AGM, AEGCL | Assam | 09854015601 |
| 5. | Sh. B.C. Borah, AGM, SLDC | Assam | 09435119248 |
| | No Representatives | Manipur | |
| 6. | Sh. B. Wankhar, EE, MePTCL | Meghalaya | 09436105914 |
| 7. | Sh. T. Gidon, EE, MePTCL | Meghalaya | 08974027950 |
| 8. | Sh. Lalduhawma, EE, SLDC | Mizoram | 09436144113 |
| 9. | Sh. C.C. Lalrimawia, SDO, P&E Deptt. | Mizoram | 09436155551 |
| 10. | Sh. B. Joy. Singh, JE, MRT | Mizoram | 09436365776 |
| 11. | Sh. Rokobeito Iralu, SDO (Trans) | Nagaland | 09436832020 |
| 12. | Sh. D. Pal, Sr. Manager | Tripura | 09436500244 |
| 13. | Sh. U. Debbarma, DGM | Tripura | 09436462842 |
| 14. | Sh. P. Kanungo, DGM (AM) | PGCIL | 09436302823 |
| 15. | Sh. T.S. Singh, GM | NERLDC | 09436302717 |
| 16. | Sh. A. Mallick, DGM (SO-II) | NERLDC | 09436302720 |
| 17. | Sh. Rahul Chakrabarti, Sr. Engr. (SO-II) | NERLDC | 09402507543 |
| 18. | Sh. Babul Roy, Manager (MO) | NERLDC | 09436335377 |
| 19. | Sh. Anupam Kumar, Sr. Engr. (SO-II) | NERLDC | 09436335379 |
| 20. | Sh. Tanya Taji, Sr. Manager | NEEPCO | 09436042053 |
| 21. | Sh. Deepak Chetia, Dy. Manager (EMD) | NTPC | 09435325996 |
| 22. | Sh. Atanu Nath, Associate Manager | ENICL | 09547808241 |
| 23. | Sh. Rodik H. Dy. Manager (E) | NHPC | 09402277414 |
| 24. | Sh. Narendra Kr Gupta, Manager | OTPC | 09774233426 |
| 25. | Sh. P.K. Mishra, Member Secretary | NERPC | 09968380242 |
| 26. | Sh. B. Lyngkhoi, Director/S.E (O) | NERPC | 09436163419 |
| 27. | Sh. S.M. Jha, E.E | NERPC | 08731845175 |

Annexure - C. 2

| SN | Name of State | Total Quantum of Load Shedding required | Location where URF installed (Feeder's Name) | Stage | Load in each feeder | Quantum of Load shedding (MW) implemented | Additional quantum of load shedding required |
|----|---------------|---|--|---------------------------------------|---------------------|---|--|
| 1 | Ar. Pradesh | 20 | At SMS Smelters (33 KV Lekhi feeders - 3 Nos) | Stage - I (49.2 Hz) | | 3.5 | 1.5 |
| | | | At Platinum Alloys (11 KV Lekhi feeders - 3 Nos) | Stage - II (49.0 Hz) | | 0 | 5 |
| | | | At Satyam Ispat Ltd. (33 KV Lekhi feeders - 3 Nos) | Stage - III (48.8 Hz) | | 0 | 5 |
| | | | At Nirjuli feeder (11 KV Lekhi feeder - 1 No.) | Stage - IV (48.6 Hz) | | 0 | 5 |
| 2 | Assam | 220 | At Gauripur (132 KV Dhaligoan - Gossaigoan - Gauripur) | Stage - I (49.2 HZ) | 16 | 54.5 | 0 |
| | | | At Sipajhar (132 KV Depota - Rowta - Sipajhar) | | 10 | | |
| | | | At Dhemaji (132 KV Gohpur - Nalkata - Dhemaji) | | 11 | | |
| | | | At Majuli (132 KV Nalkata - Majuli) | | 2.5 | | |
| | | | At Baghjap (132 KV Kahilipara - Chandrapur - Baghjap) | | 15 | | |
| | | | At Diphu (132 KV Samaguri - Sankardev - Diphu) | Stage - II (49.0 HZ) | 11 | 61 | 0 |
| | | | At Gohpur (132 KV Samaguri - B. Chariali - Gohpur) | | 8 | | |
| | | | At Rupai (132 KV Tinsukia - Rupai + AP Load) | | 17 | | |
| | | | At Jogighopa (132 KV Dhaligoan - Jogighopa) | | 7 | | |
| | | | At Sankardevnagar (132 KV Samaguri - Sankardevnagar) | | 18 | | |

| SN | Name of State | Total Quantum of Load Shedding required | Location where URF installed (Feeder's Name) | Stage | Load in each feeder | Quantum of Load shedding (MW) implemented | Additional quantum of load shedding required |
|----|---------------|---|---|--|---------------------|---|--|
| | | | | | | | |
| 2 | Assam | | At Gossaigoan (132 KV Dhaligoan - Gossaigoan) | Stage - III (48.8 Hz) | 7 | 59 | 0 |
| | | | At Rowta (132 KV Depota - Rowta) | | 18 | | |
| | | | At Chandrapur (132 KV Kahilipara - Chandrapur) | | 12 | | |
| | | | At Nalkata (132 KV Gohpur - Nalkata) | | 11 | | |
| | | | At Bokakhat (132 KV Jorhat - Bokakhat) | | 11 | | |
| | | | At Sishugram (132 KV Sarusajai - Sishugram) | 45 | 57 | 0 | |
| | | | At Ledo (132 KV Tinsukia - Ledo) | 12 | | | |
| | | | | | | | |
| 3 | Manipur | 20 | At Yurembam (33 KV Yurembam - Leimakhong) | Stage - I (49.2 Hz) | | 3 | 2 |
| | | | At Yaingangpokpi (33 KV Yaingangpokpi - Napetpalli) | Stage - II (49.0Hz) | | 0 | 5 |
| | | | At Kongba (33 KV Kongba - Mongsangei) | Stage - II (48.8Hz) | | 0 | 5 |
| | | | At Kakching (33 KV Kakching - Wangjing) | Stage - II (48.6Hz) | | 0 | 5 |

| SN | Name of State | Total Quantum of Load Shedding required | Location where URF installed (Feeder's Name) | Stage | Load in each feeder | Quantum of Load shedding (MW) implemented | Additional quantum of load shedding required |
|----|---------------|---|--|--|---------------------|---|--|
| 4 | Meghalaya | 60 | At Nangalbibra (33 KV Mendipathar - Nangalbibra) | Stage - I (49.2 Hz) | 6.5 | 15 | 0 |
| | | | At Rongkhon (33 KV Garobadha I - Rongkhon) | | 8.5 | | |
| | | | At Mawphlang (132/33 KV, 20 MVA Transformer) | Stage - II (49.0 Hz) | | 15 | 0 |
| | | | At Khliehriat (132/33 KV, 20 MVA Transformer) | Stage - III (48.8 Hz) | 12 | 15 | 0 |
| | | | At Nongstoin (33 KV Nongstoin - Mairang) | | 3 | | |
| | | | At Mawlai (33 KV Mawlai - Nongthymmai) | Stage - IV (48.6 Hz) | 7.5 | 15 | 0 |
| | | | At NEHU (33 KV NEHU - Happy Valley) | | 7.5 | | |
| 5 | Mizoram | 20 | At 132 KV Khawiva (33 KV Khawiva - Sazaikawn) | Stage - I (49.2 Hz) | 2.38 | 5.09 | 0 |
| | | | At Bukpui (33 KV Bukpui - Chhingchhip) | | 2.71 | | |
| | | | At Zuangtui (6.3 MVA, 33/11 KV Transformer - I) | Stage - II (49.0 Hz) | 5.31 | 5.31 | 0 |
| | | | At Zuangtui (6.3 MVA, 33/11 KV Transformer - II) | Stage - III (48.8 Hz) | 4 | 5.1 | 0 |
| | | | At Tlangnuam (33 KV Tlangnuam - Aibawk) | | 1.1 | | |
| | | | At Chawnpui (6.3 MVA, 33/11 KV Transformer - I) | Stage - III (48.6 Hz) | 3 | 5.2 | 0 |
| | | | At Zuangtui (11 KV Zuangtui - Chaltlang) | | 2.2 | | |

| SN | Name of State | Total Quantum | Location where URF installed (Feeder's | Stage | Load in each | Quantum of Load | Additional |
|----|---------------|---------------|--|--------------------------|--------------|-----------------|------------|
| 6 | Nagaland | 20 | At Mokokchung (66 KV Mokokchung - Tuli) | Stage - I (49.2 Hz) | | 6 | 0 |
| | | | At Dimapur (33 KV Dimapur - AP -I) | Stage - II (49.0 Hz) | | 4.5 | 0 |
| | | | At Kohima (132 KV Kohima - Wokha) | Stage - III (48.8 Hz) | | 5 | 0 |
| | | | At Dimapur (33 KV Dimapur - Refferal Hospital) | Stage - IV (48.6 Hz) | | 4.5 | 0 |
| 7 | Tripura | 40 | At Badharghat (33 KV Badarghat - Bishalghar) | Stage - I (49.2 Hz) | 8.5 | 11 | 0 |
| | | | At Badharghat (33 KV Badarghat - Takarjala) | | 2.5 | | |
| | | | At 66 KV Rabindra Nagar (33 KV Rabindra Nagar - Melaghar) | Stage - II (49.0 Hz) | 6.5 | 10 | 0 |
| | | | At 66 KV Rabindra Nagar (33 KV Rabindra Nagar - Kathalia) | | 3.5 | | |
| | | | At 79 Tilla (33 KV, 79 Tilla - Mohanpur) | Stage - III (48.8 Hz) | 7.5 | 14.5 | 0 |
| | | | At 79 Tilla (33 KV, 79 Tilla - Durjoy Nagar) | | 7 | | |
| | | | At 79 Tilla (33 KV, 79 Tilla - College Tilla) | Stage - IV (48.6 Hz) | | 12.5 | 0 |

Note: The inbuilt UFR of existing Numerical Relay at identified locations (at 132 KV level) of Assam, Meghalaya & Tripura can be used for above purpose. Existing UFR can also be shifted to new locations, wherever required.

In respect of Ar. Pradesh, Manipur, Mizoram & Nagaland: Setting of existing UFR needs to be changed in case they use the same Feeder. (i.e. 48.8 Hz to be set to 49.2 Hz for Stage - I), (48.5 to be set to 49.0 Hz for Stage - II) & (48.2 Hz to 48.8 Hz for Stage - III) Feeder is to be identified at the earliest for remaining quantum of load shedding of other stages of 48.8 Hz & 48.6 Hz.

STATUS OF UFR IMPLEMENTATION IN NER

| Stage | Load shed Required | Implemented | To be Implemented |
|------------------------------|---------------------------|--------------------|--------------------------|
| Stage - I (49.2 Hz) | 100 MW | 98.09 | 1.91 |
| Stage - II (49.0 Hz) | 100 MW | 95.8 | 4.19 |
| Stage - III (48.8 Hz) | 100 MW | 98.6 | 1.4 |
| Stage - IV (48.6 Hz) | 100 MW | 94.2 | 5.8 |
| TOTAL | 400 MW | 386.69 | 13.3 |

Line Loading Enhancement Requirement (Under Peak Hours)

| Sl. No | Name of Transmission Line | Transmission Line/ Generator under outage | Contingency |
|--------|-------------------------------------|---|---|
| 1 | 132 kV AGTPP-Agartala I | 132 kV AGTPP-Kumarghat | N-1 : 132 kV AGTPP-Agartala II |
| | 132 kV AGTPP-Agartala II | 132 kV AGTPP-Kumarghat | N-1 : 132 kV AGTPP-Agartala I |
| 2 | 132 kV AGTPP-Kumarghat | 132 kV AGTPP-Agartala I | N-1 : 132 kV AGTPP-Agartala II |
| 3 | 132 kV Badarpur-Jiribam | Nil | N-1 : 400 kV Silchar-Azara |
| 4 | 132 kV Badarpur-Khliehriat | Nil | N-1 : 400 kV Silchar-Azara |
| 5 | 132 kV Badarpur-Khliehriat | Palatana & 400 kV Silchar-Azara | N-1 : 400 kV Silchar-Byrnihat |
| 6 | 132 kV Badarpur-Panchgram | Nil | N-1 : 132 kV Badarpur-Silchar D/C |
| 7 | 132 kV Badarpur-Kolasib | 132 kV Jiribam-Aizawl | N-1 : 132 kV Kumarghat-Aizawl |
| 8 | 132 kV Dimapur-Imphal | Nil | N-1 : 132 kV Loktak-Jiribam |
| 9 | 132 kV Dimapur-Imphal | Nil | N-1 : 132 kV Loktak-Jiribam |
| 10 | 132 kV Jiribam-Aizawl | 132 kV Aizawl-Kolasib | N-1 : 132 kV Kumarghat-Aizawl |
| 11 | 132 kV Khandong-Khliehriat I | Nil | N-1 : 132 kV Khandong-Khliehriat II |
| | 133 kV Khandong-Khliehriat II | Nil | N-1 : 132 kV Khandong-Khliehriat I |
| 12 | 132 kV Khliehriat(PG)-Khliehriat I | Nil | N-1 : 132 kV Khliehriat(PG)-Khliehriat II |
| | 132 kV Khliehriat(PG)-Khliehriat II | Nil | N-1 : 132 kV Khliehriat(PG)-Khliehriat I |
| 13 | 132 kV Killing-EPIP II-I | Nil | N-1 : 132 kV Killing-EPIP II-II |
| | 132 kV Killing-EPIP II-II | Nil | N-1 : 132 kV Killing-EPIP II-I |
| 14 | 132 kV Kopili-Khandong I | Nil | N-1 : 132 kV Kopili-Khandong II |
| | 132 kV Kopili-Khandong II | Nil | N-1 : 132 kV Kopili-Khandong I |
| 15 | 132 kV Kumarghat-Aizawl | 132 kV Kolasib-aizawl | N-1 : 132 kV Jiribam-Aizawl |
| 16 | 132 kV Loktak-Jiribam | Nil | N-1 : 132 kV Dimapur-Imphal S/C |
| 17 | 132 kV Loktak-Jiribam | Nil | N-1 : 132 kV Dimapur-Imphal |
| 18 | 132 kV Loktak-Imphal | Nil | N-1 : 132 kV Loktak-Ningthoukong |
| 19 | 132 kV Loktak-Ningthoukong | Nil | N-1 : 132 kV Loktak-Imphal |
| 20 | 132 kV Palatana-Udaipur | Nil | N-1 : 132 kV Palatana-Surjamaninagar |
| 21 | 132 kV Palatana-Surjamaninagar | Nil | N-1 : 132 kV Palatana-Udaipur |
| 22 | 132 kV Raganadi-Nirjuli | Nil | Nil |
| 23 | 132 kV Silchar-Srikona I | Nil | N-1 : 132 kV Silchar-Srikona II |
| | 132 kV Silchar-Srikona II | Nil | N-1 : 132 kV Silchar-Srikona I |
| 24 | 132 kV BTPS-Dhaligaon I | Nil | N-1 : 132 kV BTPS-Dhaligaon II |
| | 132 kV BTPS-Dhaligaon II | Nil | N-1 : 132 kV BTPS-Dhaligaon I |
| 25 | 132 kV Balipara-Depota | Nil | Nil |
| 26 | 220 kV Mariani(AS)-Misa | 220 kV Mariani(PG)-Misa | Nil |
| 27 | 220 kV Misa-Samaguri I | Nil | N-1 : 220 kV Misa-Samaguri II |
| | 220 kV Misa-Samaguri II | Nil | N-1 : 220 kV Misa-Samaguri I |
| 28 | 220 kV AGBPP-Mariani | 220 kV AGBPP-Tinsukia I & II | N-1 : 220 kV AGBPP-Mariani(PG) |

**Dynamic data of
Generator Models required in
PSS®E for Dynamic Simulation**

**North Eastern Regional Load Despatch Centre
Shillong**

Summary of North Eastern Region Models in PSS®E

- No. of Generators – 91 Nos (including States)
 - Thermal Generators- 47 Nos.
 - Hydro Generators- 44 Nos.
- Multi terminal HVDC – 1 No.

Connection Agreement

- **For ISTS connectivity,**

Generators have to mandatorily sign the connection agreement with CTU. As part of Connection Agreement with CTU

- Generator and Exciter Data is provided
- Governor, Power System Stabilizer and Excitation Limiter (OEL and UEL) models are not provided

- **For Intra-State Generators,**

- SLDCs need to collect the data from Generators for modelling purpose

PSSE Models

- **Generator Models**

- **GENROU** (Thermal) / **GENSAL** (Hydro)

- **Governor Models**

- TGOV1 / HYGOV / GGOV1 / GAST

- **Exciter Models**

- IEEET1/ IEEET2 / SCRX / SEXS / ESDC1A /EXAC1A

- **Stabilizer Models**

- IEEEST / IEE2ST / PSS2A / PSS2B

Availability of Dynamics Data

- **Generator Data – only ISGS are available**
 - **GENROU** data is available from the following generators
 - Palatana (GTG I, GTG II, STG I & STG II- except S(1.0) & S(1.2))
 - BgTPP (Unit 1, 2 & 3- except S(1.2))
 - AGBPP (Unit 1,2,3,4,5,6, 7, 8 & 9)
 - AGTPP (Unit 1, 2,3 & 4 - only D-axis data)
 - Monarchak (GT I- only D-axis data)
 - AGTPP Extension (STG 1 & 2- except S(1.0) & S(1.2))
 - **GENSAL** data is available from the following generators
 - Doyang (Unit 1,2 & 3- only X_d , X_d' & X_d'')
 - Kopili (Unit 1,2,3 & 4- except $T''d_0$, $T''q_0$, S(1.0) & S(1.2))
 - Khandong (Unit 1 & 2 - except $T''q_0$, D, X_l , S(1.0) & S(1.2))
 - Kopili Stg II (except $T''q_0$, D, X_l , S(1.0) & S(1.2))
 - Ranganadi (Unit 1, 2, & 3, - except $T''q_0$, H, D, S(1.0) & S(1.2))
 - Loktak (Unit 1,2 & 3- except $T''d_0$, $T''q_0$, D, $X'd$, X_l , S(1.0) & S(1.2))

Availability of Dynamics Data

- **Exciter data & Governor data**
 - AGBPP (Unit 1,2, 3 & 4- partially given for both)
 - Palatana (Block diagram of Exciter and Digital AVR given, Values of constants missing from Block Diagram)
 - BgTPP (Block diagram of Digital AVR given, values of constants missing from Block Diagram)
 - Monarchak (Block diagram of Exciter given)
 - Loktak (only Exciter data given; needs validation as values out of range as per setting of PSSE)

Transfer function of Digital AVR provided by BgTPP and OTPC are exactly the same.

- **PSS data is not available for any machines.**

Thank You

Generator models contained in the PSS®E dynamics model library

| Model | Description |
|----------|---|
| CBEST | EPRI battery energy storage FACTS model |
| CDSMS1 | American Superconductor DSMES device model |
| CGEN1 | Third order generator model |
| CIMTR1 | Induction generator model with rotor flux transients |
| CIMTR2 | Induction motor model with rotor flux transients |
| CIMTR3 | Induction generator model with rotor flux transients |
| CIMTR4 | Induction motor model with rotor flux transients |
| CSMEST | EPRI superconducting electromagnetic energy storage FACTS model |
| CSTAT | Static condenser FACTS model |
| CSVGN1 | SCR controlled static var source model |
| CSVGN3 | SCR controlled static var source model |
| CSVGN4 | SCR controlled static var source model |
| CSVGN5 | WECC controlled static var source model |
| CSVGN6 | WECC controlled static var source model |
| FRECHG | Salient pole frequency changer model |
| GENCLS | Classical generator model |
| GENDCO | Round rotor generator model with dc offset torque component |
| GENROE | Round rotor generator model |
| GENROU | Round rotor generator model |
| GENSAE | Salient pole generator model |
| GENSAL | Salient pole generator model |
| GENTPJU1 | WECC Type J Synchronous generator model |
| GENTRA | Transient level generator model |



GENROU-Round rotor generator model

| CONs | # | Value | Description |
|------|---|-------|-----------------------|
| J | | | T'_{do} (>0) (sec) |
| J+1 | | | T''_{do} (>0) (sec) |
| J+2 | | | T'_{qo} (>0) (sec) |
| J+3 | | | T''_{qo} (>0) (sec) |
| J+4 | | | H, Inertia |
| J+5 | | | D, Speed damping |
| J+6 | | | X_d |
| J+7 | | | X_q |
| J+8 | | | X'_d |
| J+9 | | | X'_q |
| J+10 | | | $X''_d = X''_q$ |
| J+11 | | | X_l |
| J+12 | | | S(1.0) |
| J+13 | | | S(1.2) |

X_d , X_q , X'_d , X'_q , X''_d , X''_q , X_l , H, and D are in pu, machine MVA base.

X''_q must be equal to X''_d .



GENSAL - Salient Pole Generator Model

| CONs | # | Value | Description |
|------|---|-------|-----------------------|
| J | | | T'_{do} (>0) (sec) |
| J+1 | | | T''_{do} (>0) (sec) |
| J+2 | | | T''_{qo} (>0) (sec) |
| J+3 | | | H, Inertia |
| J+4 | | | D, Speed damping |
| J+5 | | | X_d |
| J+6 | | | X_q |
| J+7 | | | X'_d |
| J+8 | | | $X''_d = X''_q$ |
| J+9 | | | X_l |
| J+10 | | | S(1.0) |
| J+11 | | | S(1.2) |

X_d , X_q , X'_d , X'_q , X''_d , X''_q , X_l , H, and D are in pu, machine MVA base.

X''_q must be equal to X''_d .



Turbine-Governor Models

| Model | Description |
|--------|---|
| BBGOV1 | Brown-Boveri turbine-governor model |
| CRCMGV | Cross compound turbine-governor model |
| DEGOV | Woodward diesel governor model |
| DEGOV1 | Woodward diesel governor model |
| GAST | Gas turbine-governor model |
| GAST2A | Gas turbine-governor model |
| GASTWD | Gas turbine-governor model |
| GGOV1 | GE general purpose turbine-governor model |
| HGOV | Hydro turbine-governor model |
| HGOV2 | Hydro turbine-governor model |
| HGOVM | Hydro turbine-governor lumped parameter model |
| HGOVRU | Fourth order lead-lag hydro-turbine |
| HGOVT | Hydro turbine-governor traveling wave model |
| IEEEG1 | 1981 IEEE type 1 turbine-governor model |
| IEEEG2 | 1981 IEEE type 2 turbine-governor model |
| IEEEG3 | 1981 IEEE type 3 turbine-governor model |
| IEESGO | 1973 IEEE standard turbine-governor model |
| IVOGO | IVO turbine-governor model |
| PIDGOV | Hydro turbine and governor model |
| SHAF25 | Torsional-elastic shaft model for 25 masses |
| TGOV1 | Steam turbine-governor model |
| TGOV2 | Steam turbine-governor model with fast valving |
| TGOV3 | Modified IEEE type 1 turbine-governor model with fast valving |
| TGOV4 | Modified IEEE type 1 speed governing model with PLU and EVA |



Contd.

Turbine-Governor Models

| Model | Description |
|--------|--|
| TGOV5 | Modified IEEE type 1 turbine-governor model with boiler controls |
| TURCZT | Czech hydro or steam turbine-governor model |
| TWDM1T | Tail water depression hydro governor model 1 |
| TWDM2T | Tail water depression hydro governor model 2 |
| URCSCT | Combined cycle, single shaft turbine-governor model |
| URGS3T | WECC gas turbine governor model |
| WEHGOV | Woodward electronic hydro governor model |
| WESGOV | Westinghouse digital governor for gas turbine |
| WPIDHY | Woodward PID hydro governor model |
| WSHYDD | WECC double derivative hydro governor model |
| WSHYGP | WECC GP hydro governor plus turbine model |
| WSIEG1 | WECC modified 1981 IEEE type 1 turbine-governor model |



GAST- Gas turbine-governor model

| CONs | # | Value | Description |
|------|---|-------|------------------------------------|
| J | | | R (speed droop) |
| J+1 | | | T_1 (>0) (sec) |
| J+2 | | | T_2 (>0) (sec) |
| J+3 | | | T_3 (>0) (sec) |
| J+4 | | | Ambient temperature load limit, AT |
| J+5 | | | K_T |
| J+6 | | | V_{MAX} |
| J+7 | | | V_{MIN} |
| J+8 | | | D_{turb} |

Contd.

GAST- Gas turbine-governor model

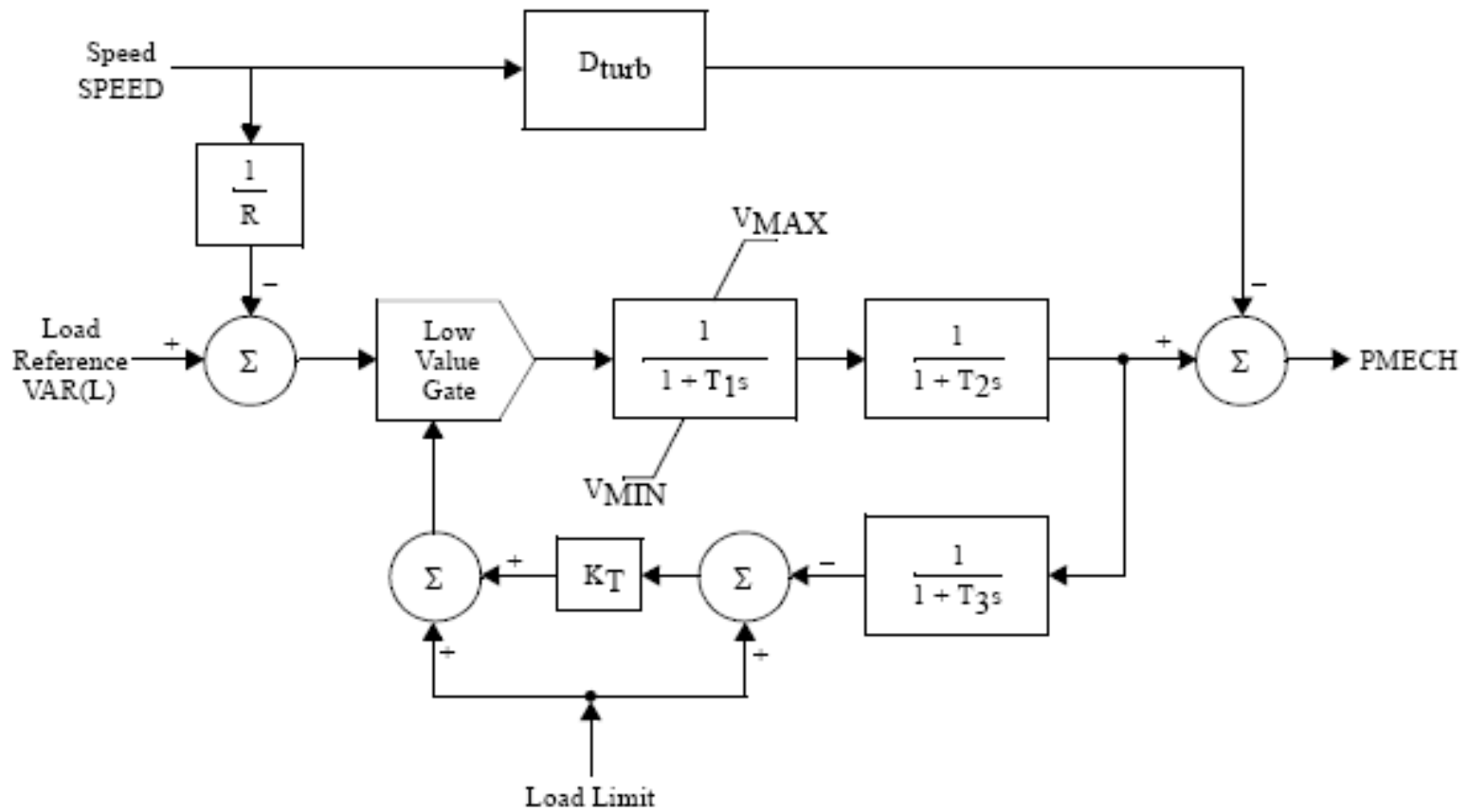

HYGOV-Hydro turbine-governor model

| CONs | # | Value | Description |
|------|---|-------|---------------------------------------|
| J | | | R, permanent droop |
| J+1 | | | r, temporary droop |
| J+2 | | | $T_r (>0)$ governor time constant |
| J+3 | | | $T_f (>0)$ filter time constant |
| J+4 | | | $T_g (>0)$ servo time constant |
| J+5 | | | \pm VELM, gate velocity limit |
| J+6 | | | G _{MAX} , maximum gate limit |
| J+7 | | | G _{MIN} , minimum gate limit |
| J+8 | | | $T_W (>0)$ water time constant |
| J+9 | | | A _t , turbine gain |
| J+10 | | | D _{turb} , turbine damping |
| J+11 | | | QNL, no power flow |

Contd.

HYGOV-Hydro turbine-governor model

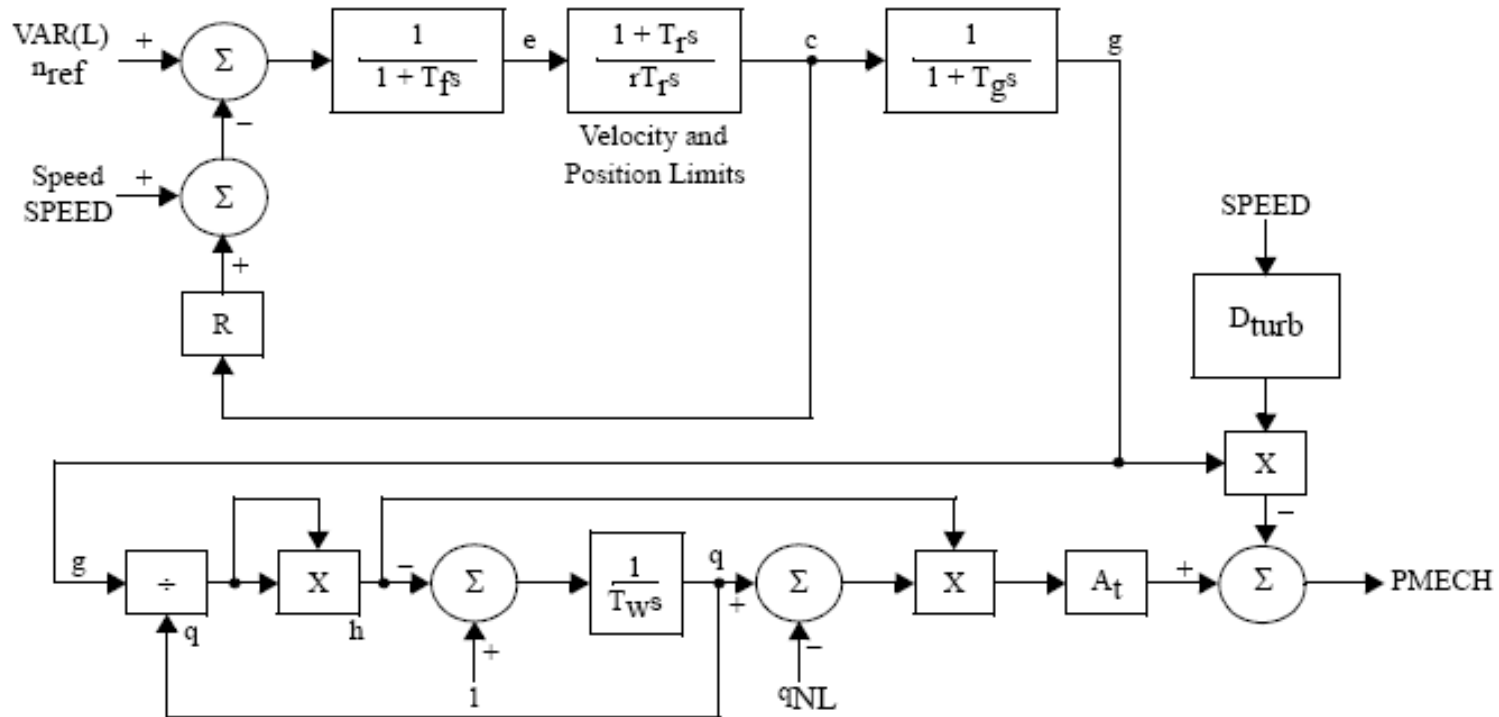

TGOV1- Steam turbine-governor model

| CONs | # | Value | Description |
|------|---|-------|-------------------------------|
| J | | | R |
| J+1 | | | $T_1 (>0)$ (sec) |
| J+2 | | | V_{MAX}^1 |
| J+3 | | | V_{MIN}^1 |
| J+4 | | | T_2 (sec) ² |
| J+5 | | | $T_3 (>0)$ (sec) ³ |
| J+6 | | | D_t^1 |

¹ V_{MAX} , V_{MIN} , D_t and R are in per unit on generator MVA base.

² T_2/T_3 = high-pressure fraction.

³ T_3 = reheater time constant.

Contd.

TGOV1- Steam turbine-governor model

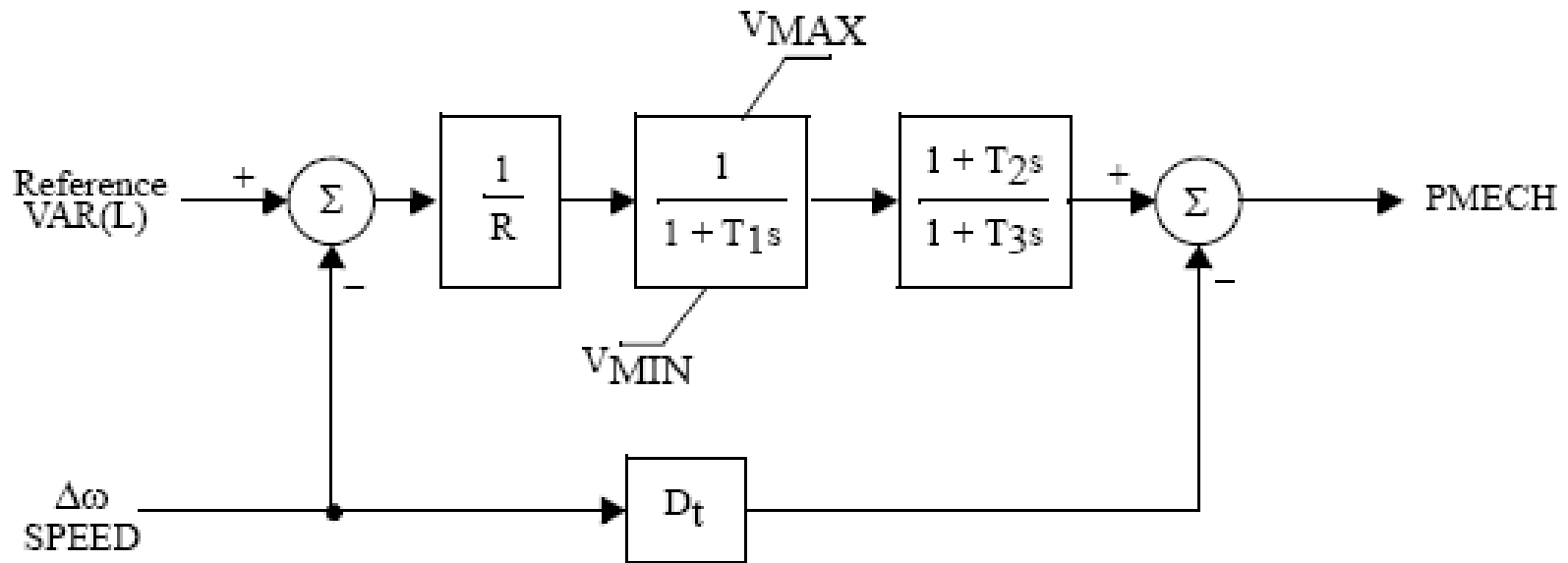

Exciter models contained in the PSS®E dynamics model library

| Model | Description |
|----------|---|
| CBEST | EPRI battery energy storage FACTS model |
| CDSMS1 | American Superconductor DSMES device model |
| CGEN1 | Third order generator model |
| CIMTR1 | Induction generator model with rotor flux transients |
| CIMTR2 | Induction motor model with rotor flux transients |
| CIMTR3 | Induction generator model with rotor flux transients |
| CIMTR4 | Induction motor model with rotor flux transients |
| CSMEST | EPRI superconducting electromagnetic energy storage FACTS model |
| CSTATT | Static condenser FACTS model |
| CSVGN1 | SCR controlled static var source model |
| CSVGN3 | SCR controlled static var source model |
| CSVGN4 | SCR controlled static var source model |
| CSVGN5 | WECC controlled static var source model |
| CSVGN6 | WECC controlled static var source model |
| FRECHG | Salient pole frequency changer model |
| GENCLS | Classical generator model |
| GENDCO | Round rotor generator model with dc offset torque component |
| GENROE | Round rotor generator model |
| GENROU | Round rotor generator model |
| GENSAE | Salient pole generator model |
| GENSAL | Salient pole generator model |
| GENTPJU1 | WECC Type J Synchronous generator model |
| GENTRA | Transient level generator model |

Contd.

Excitation System Model Data Sheets

| Model | Description |
|--------|--|
| AC7B | IEEE 421.5 2005 AC7B excitation system |
| AC8B | IEEE 421.5 2005 AC8B excitation system |
| BBSEX1 | Brown-Boveri static excitation system model |
| BUDCZT | Czech proportional/integral excitation system model |
| CELIN | ELIN brushless excitation system model |
| DC3A | IEEE 421.5 2005 DC3A excitation system |
| DC4B | IEEE 421.5 2005 DC4B excitation system |
| EMAC1T | AEP Rockport excitation system model |
| ESAC1A | 1992 IEEE type AC1A excitation system model |
| ESAC2A | 1992 IEEE type AC2A excitation system model |
| ESAC3A | 1992 IEEE type AC3A excitation system model |
| ESAC4A | 1992 IEEE type AC4A excitation system model |
| ESAC5A | 1992 IEEE type AC5A excitation system model |
| ESAC6A | 1992 IEEE type AC6A excitation system model |
| ESAC8B | Basler DECS model |
| ESDC1A | 1992 IEEE type DC1A excitation system model |
| ESDC2A | 1992 IEEE type DC2A excitation system model |
| ESST1A | 1992 IEEE type ST1A excitation system model |
| ESST2A | 1992 IEEE type ST2A excitation system model |
| ESST3A | 1992 IEEE type ST3A excitation system model |
| ESST4B | IEEE type ST4B potential or compounded source-controlled rectifier exciter |
| ESURRY | Modified IEEE Type AC1A excitation model |
| EX2000 | EX2000 Excitation System |



Contd.

Excitation System Model Data Sheets

| Model | Description |
|--------|---|
| EXAC1 | 1981 IEEE type AC1 excitation system model |
| EXAC1A | Modified type AC1 excitation system model |
| EXAC2 | 1981 IEEE type AC2 excitation system model |
| EXAC3 | 1981 IEEE type AC3 excitation system model |
| EXAC4 | 1981 IEEE type AC4 excitation system model |
| EXBAS | Basler static voltage regulator feeding dc or ac rotating exciter model |
| EXDC2 | 1981 IEEE type DC2 excitation system model |
| EXELI | Static PI transformer fed excitation system model |
| EXNEBB | Bus or solid fed SCR bridge excitation system model type NEBB (NVE) |
| EXNI | Bus or solid fed SCR bridge excitation system model type NI (NVE) |
| EXPIC1 | Proportional/integral excitation system model |
| EXST1 | 1981 IEEE type ST1 excitation system model |
| EXST2 | 1981 IEEE type ST2 excitation system model |
| EXST2A | Modified 1981 IEEE type ST2 excitation system model |
| EXST3 | 1981 IEEE type ST3 excitation system model |
| IEEET1 | 1968 IEEE type 1 excitation system model |
| IEEET2 | 1968 IEEE type 2 excitation system model |
| IEEET3 | 1968 IEEE type 3 excitation system model |
| IEEET4 | 1968 IEEE type 4 excitation system model |
| IEEET5 | Modified 1968 IEEE type 4 excitation system model |
| IEEEX1 | 1979 IEEE type 1 excitation system model and 1981 IEEE type DC1 model |
| IEEEX2 | 1979 IEEE type 2 excitation system model |
| IEEEX3 | 1979 IEEE type 3 excitation system model |
| IEEEX4 | 1979 IEEE type 4 excitation system, 1981 IEEE type DC3 and 1992 IEEE type DC3A models |
| IEET1A | Modified 1968 IEEE type 1 excitation system model |
| IEET1B | Modified 1968 IEEE type 1 excitation system model |



Contd.

Excitation System Model Data Sheets

| Model | Description |
|---------|---|
| REXSYS | General purpose rotating excitation system model |
| SCRX | Bus or solid fed SCR bridge excitation system model |
| SEXS | Simplified excitation system model |
| ST5B | IEEE 421.5 2005 ST5B excitation system |
| ST6B | IEEE 421.5 2005 ST6B excitation system |
| ST7B | IEEE 421.5 2005 ST7B excitation system |
| USAC6AU | Modified ESAC6A Model |
| URHIDT | High dam excitation system model |
| URST5T | IEEE proposed type ST5B excitation system |



CELIN-ELIN Brushless Excitation System

POWER SYSTEM STABILIZER

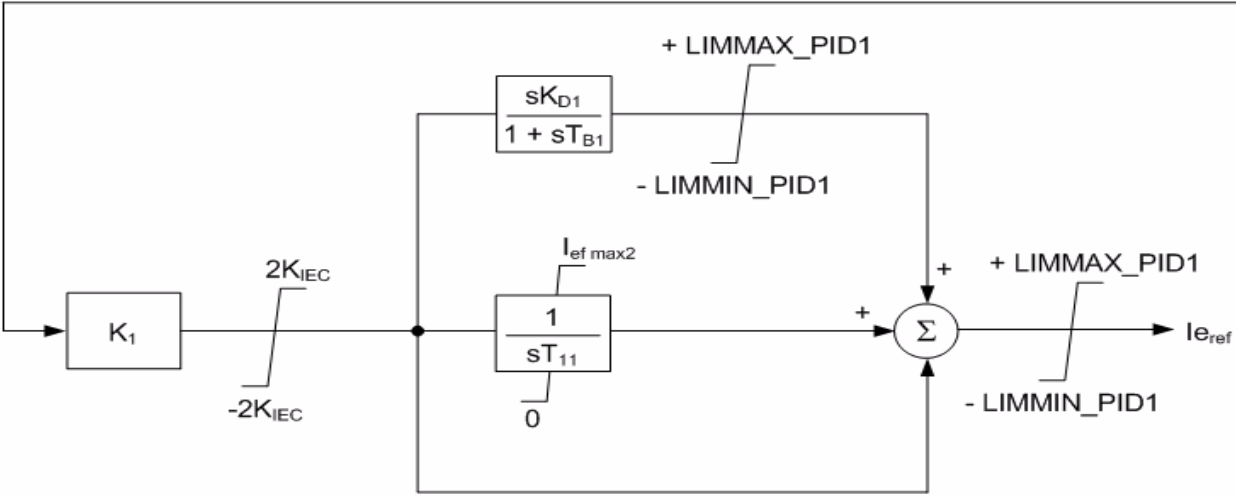
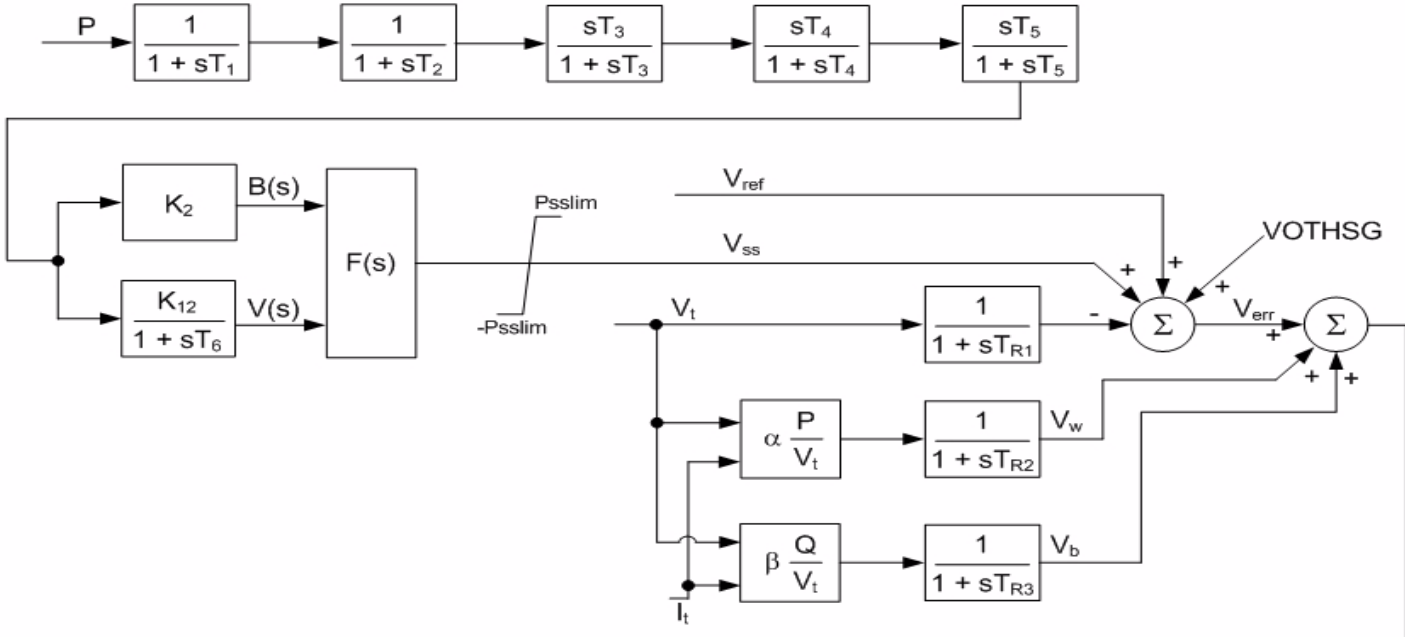

VOLTAGE REGULATOR



ESDC1A- 1992 IEEE type DC1A excitation system model

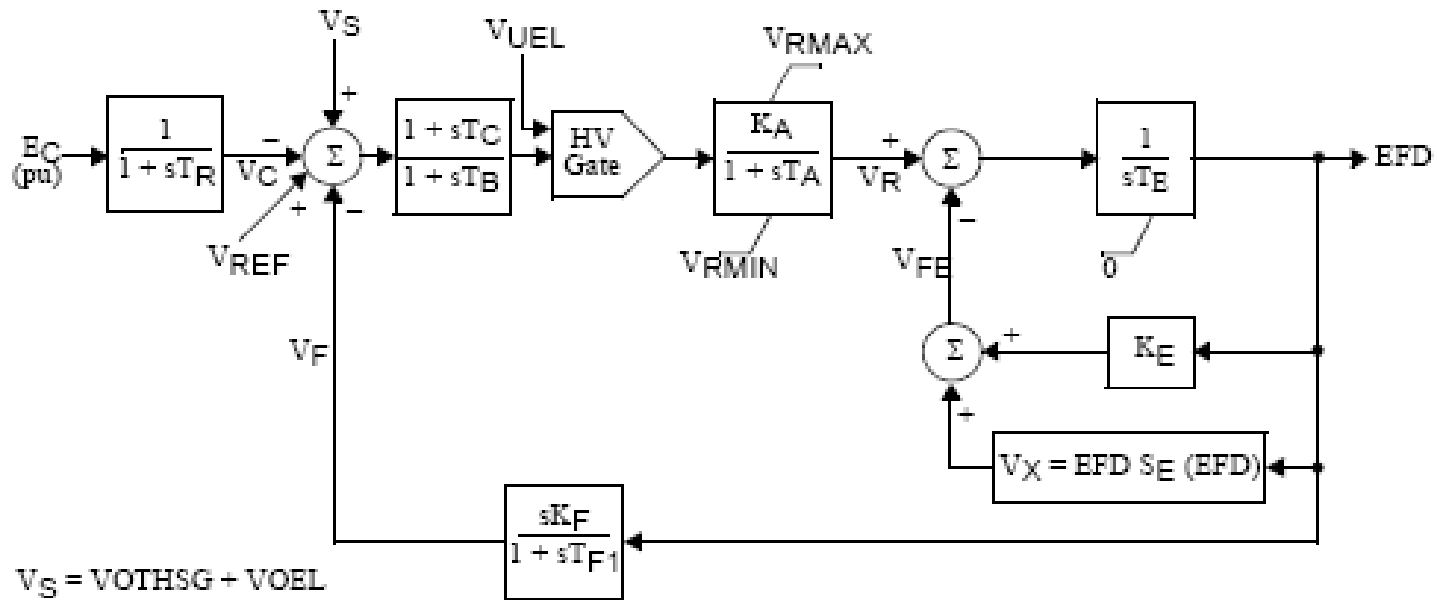

EXAC1A- Modified type AC1 excitation system model

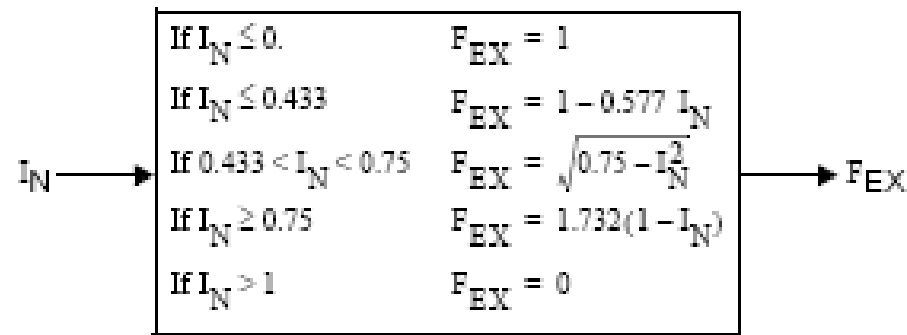
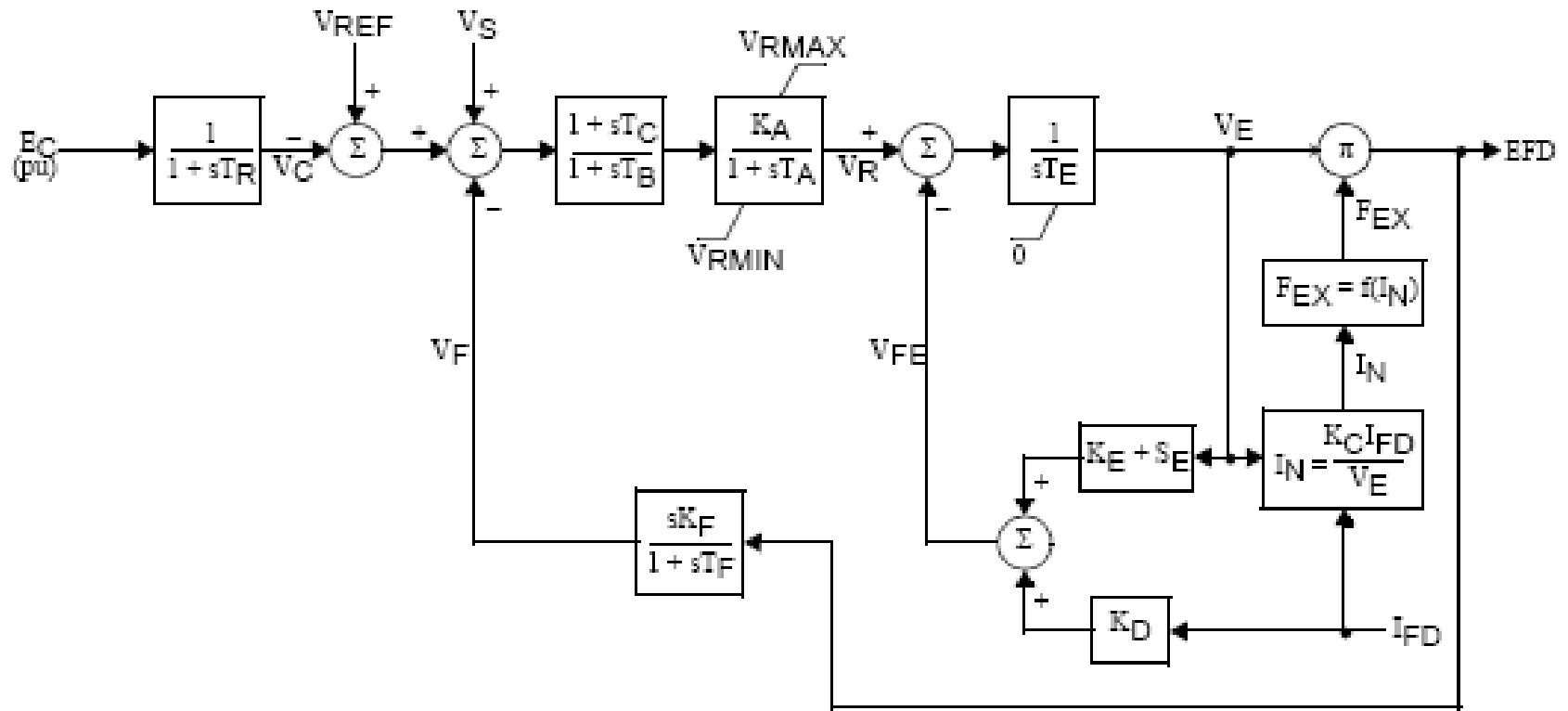

$$V_S = V_{OTHSG} + V_{UEL} + V_{OEL}$$

IEEE Type 1 Excitation System

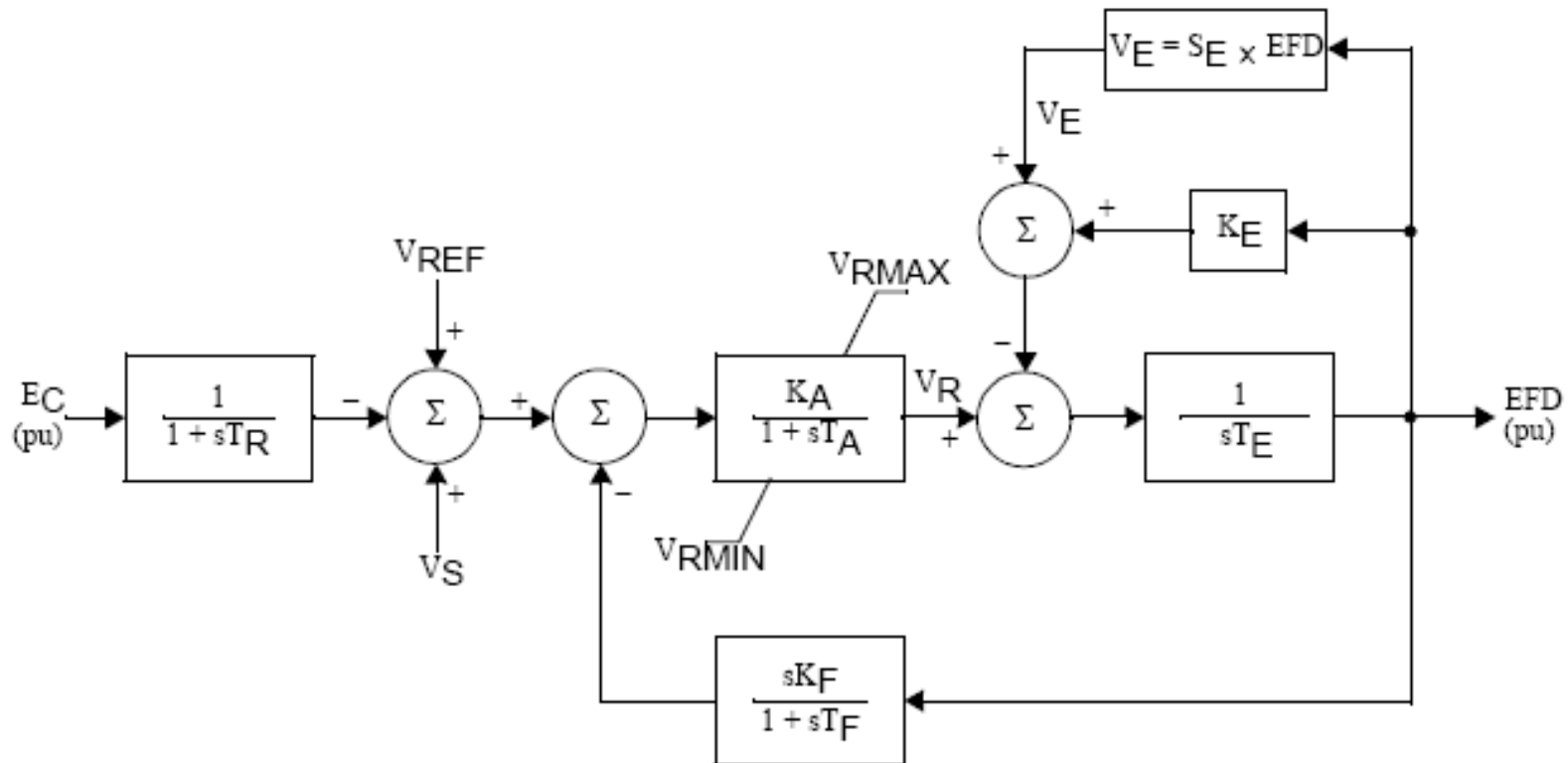

$$V_S = V_{OTHSG} + V_{UEL} + V_{OEL}$$

Note: S_E is the saturation function.



SCRX- Bus or solid fed SCR bridge excitation system model

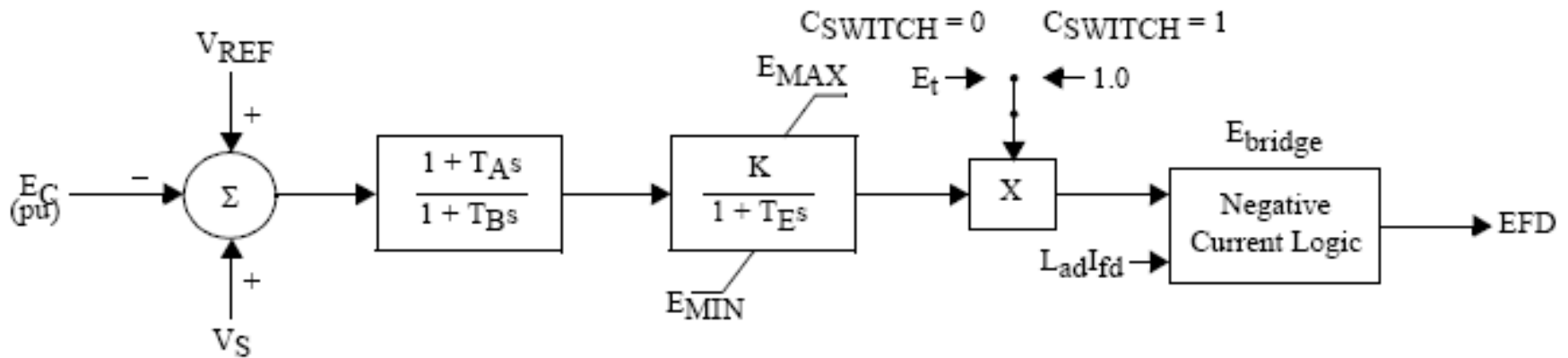

$$V_S = V_{OTHSG} + V_{UEL} + V_{OEL}$$



SEXS- Simplified excitation system model

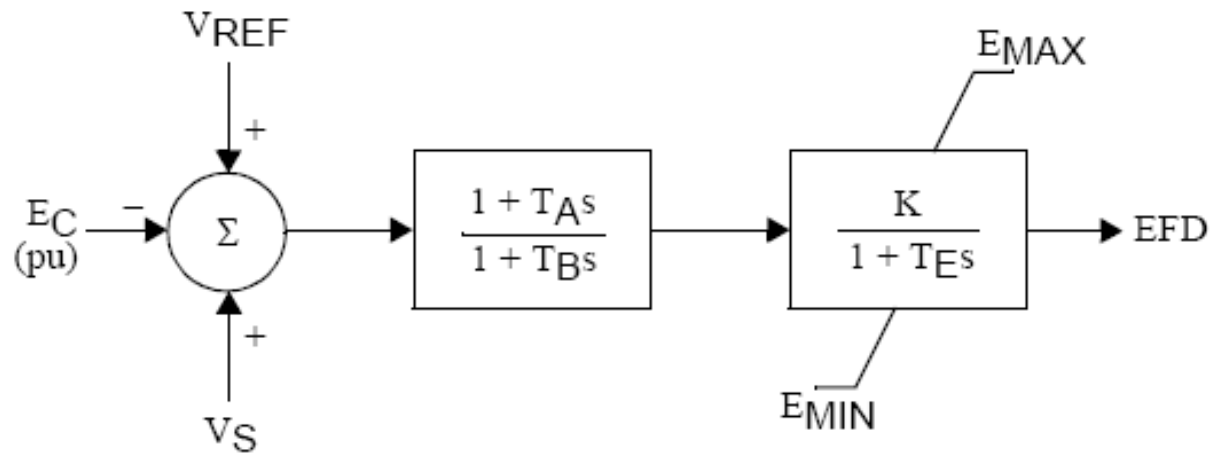

$$V_S = V_{OTHSG} + V_{UEL} + V_{OEL}$$



Stabilizer models

| Model | Description |
|---------|---|
| BEPSST | Transient excitation boosting stabilizer model |
| IEE2ST | Dual-input signal power system stabilizer model |
| IEEEEST | 1981 IEEE power system stabilizer model |
| IVOST | IVO stabilizer model |
| OSTB2T | Ontario Hydro delta-omega power system stabilizer |
| OSTB5T | Ontario Hydro delta-omega power system stabilizer |
| PSS1A | IEEE Std. 421.5-2005 PSS1A Single-Input Stabilizer model |
| PSS2A | 1992 IEEE type PSS2A dual-input signal stabilizer model |
| PSS2B | IEEE 421.5 2005 PSS2B IEEE dual-input stabilizer model |
| PSS3B | IEEE Std. 421.5 2005 PSS3B IEEE dual-input stabilizer model |
| PSS4B | IEEE 421.5(2005) dual-input stabilizer model |
| PTIST1 | PTI microprocessor-based stabilizer model |
| PTIST3 | PTI microprocessor-based stabilizer model |
| ST2CUT | Dual-input signal power system stabilizer model |
| STAB1 | Speed sensitive stabilizer model |
| STAB2A | ASEA power sensitive stabilizer model |
| STAB3 | Power sensitive stabilizer model |
| STAB4 | Power sensitive stabilizer model |
| STABNI | Power sensitive stabilizer model type NI (NVE) |
| STBSVC | WECC supplementary signal for static var system |



PSS2A- 1992 IEEE type PSS2A dual-input signal stabilizer model

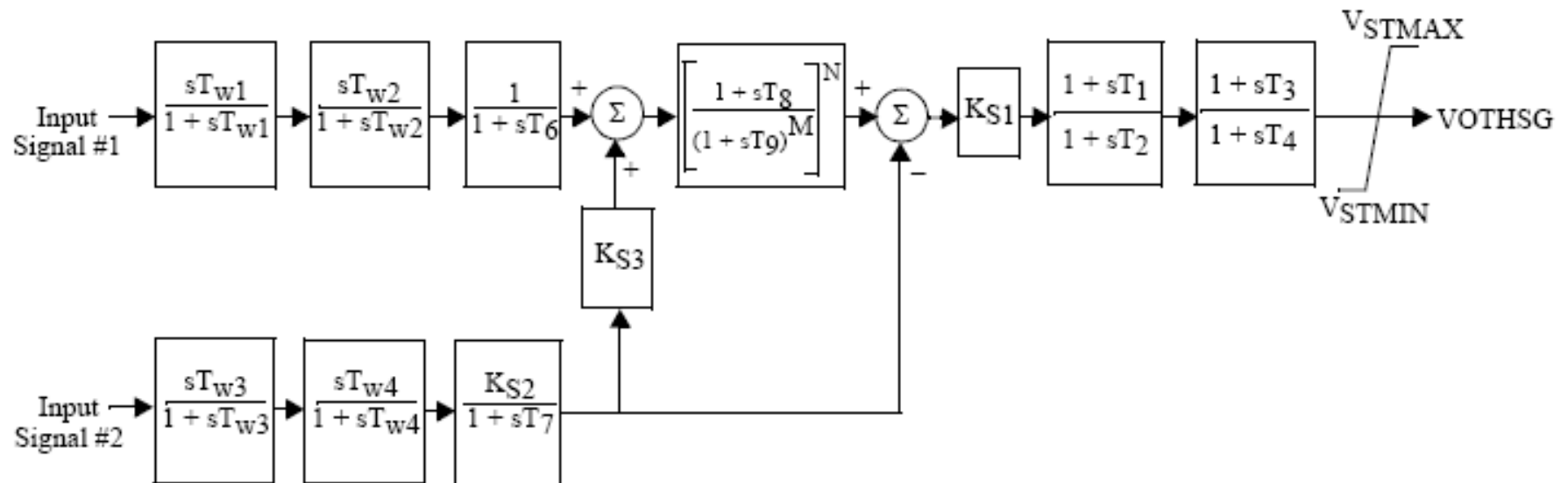

ANNEXURE-D.7

Brief on CERC (Sharing of Inter State Transmission Charges and Losses) (Third Amendment) Regulations, 2015.

- Third Amendment to the sharing of Inter State Transmission Charges and Losses Regulations notified vide L-1/44/2010-CERC dated 1st April 2015.
- The amended regulations will be effective from **1st May 2015**.
- The Central Electricity Regulatory Commission (Sharing of Inter-State Transmission Charges & Losses) Regulations, 2010 hereinafter to be referred as **“The Principal Regulations**
- **Application Period** means the period of application of the charges determined as per these regulations and shall be of **3 (three) months duration** i.e. April to June, July to September, October to December, and January to March in a financial year. Provided that in exceptional circumstances, the Commission may extend or curtail the duration of the application period for the reasons to be recorded in writing.
- **Approved Injection** to be calculated on the basis of maximum injection made during corresponding application periods of last three years as against average figures earlier. Provided that the overload capability of a generating unit shall not be used for calculating the approved injection.
- **Approved Withdrawal** to be calculated on the basis of actual peak met during corresponding application periods of last three years as against average figures earlier.
- Definition of **Designated ISTS Customer (DIC)** modified to also include any intra-State entity who has obtained Medium Term Open Access or long Term Access to ISTS.
- Concept of Uniform charge and Uniform Loss removed
- New terms introduced:
 - **HVDC charge** – transmission charges shared for use of HVDC system
 - **Reliability Support Charge** - Charge for reliability benefits by virtue of operating in an integrated grid.
 - **Merchant Power Plant** -generating station whose tariff either for the whole capacity or for the part capacity is not determined under section 62 or section 63 of the Act and which sells electricity in the open market corresponding to such capacity.
- Node wise forecast injection data and demand data to be submitted by the DICs for each application period. Forecasted injection/demand data to incorporate estimate of total maximum injection to the grid / maximum withdrawal from the grid.
- **Mis-declaration by a DIC** beyond +/-20% for two consecutive quarters shall be treated as gaming. Unless reasonably explained by the concerned DIC, the

Implementing Agency shall report the matter to the Commission for appropriate directions.

- In case of non-submission of injection data by SLDC, difference between peak met and withdrawal from ISTS based on actual metered data to be considered **(for the time block corresponding to the block in which peak met occurred)**.
- The forecast generation in respect of each DIC shall be normalized with respect to forecast All India Peak Demand met to create base case for load generation balance to arrive at the approved injection.
- Normalization factor:
$$\frac{\text{Projected All India Peak Demand Met}}{\text{Sum of projected met for all states}}$$
- If sum of projected generation in the grid is more than sum of projected demand, the generation may be proportionately reduced to match sum of withdrawal data. If sum of projected generation in the grid is less than sum of projected demand, the demand may be proportionately reduced to match sum of generation.
- **Nine (9) slabs** for Point of Connection charges. Earlier there were three (3) slabs. Number of slabs to be reviewed by the Commission after 2 years.
- **Full All India Network** to be considered for the calculations. Earlier All India network truncated at 400kV except for NER where network till 132kV level was considered.
- Recovery of Yearly Transmission Charges (YTC) of the ISTS network based on **Hybrid Methodology (PoC charge), Reliability Support Charge and HVDC charge**.
- 10% of total YTC (including HVDC) to be recovered through Reliability support charge sharing methodology. Withdrawal DICs to pay reliability support charge in proportion to their Approved Withdrawal. For Injection DIC having LTA to target region, the charges are payable in proportion to their Approved Injection.
- Reliability support charges not to be mixed with zonal PoC rates and to be determined separately.
- 90% of total YTC (excluding HVDC) to be recovered through Hybrid methodology (PoC charge). Balance 90% YTC of HVDC assets shall be payable by DICs of the region (for whose benefit HVDC system was created) in proportion to their approved withdrawal/injection.
- PoC rates to be calculated for Withdrawal nodes (as withdrawal charges) and for generators who have LTA to target region without identified beneficiaries (as injection charges). PoC rates not to be calculated for ISGS with identified long term customers/beneficiaries with whom PPA have been signed.
- **Losses** to be calculated as per Hybrid methodology (PoC Loss).
- Nine slabs (in percentage) for calculation of transmission loss. Slab size of 0.25% subject to minimum loss of 0%. Slabs to be reviewed by the Commission after two years.
- **Non-submission of data** in time for computation of transmission charges shall be treated as non-compliance of the regulations and action as considered

appropriate shall be taken by the Commission after giving an opportunity of hearing to the defaulting DIC

Suggested Timeline of each Quarter for executing various processes related to PoC Computation:

- 10th of 1st month-Last Day for submission of tariff petitions by transmission licensees
- 20th of 1st month- Submission of Node wise data by States/DICs
- 30th of 1st month-Preparation of Basic network using nodal generation and nodal demand submitted by states/DICs
- 10th of 2nd month-Provisional tariff orders by CERC
- By 10th of 2nd month-Validation Committee Meeting
- 15th of 2nd month-Submission of Final YTC data to the Implementing Agency by Transmission Licensees
- 10 of 3rd month-Submission of Final Result to CERC by the Implementing agency
- 20th of 3rd month-Final order on PoC Charges and Losses by Central Electricity Regulatory Commission